

Technical features

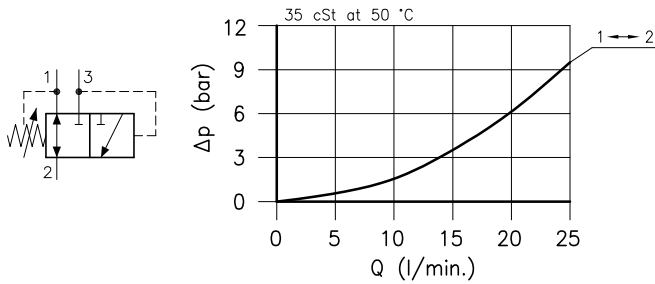

Cavity	(For dimensions see catalogue 17.000)	S 20/3
Nominal flow	(l/min.)	20
Max. pressure	(bar)	350
Fluid viscosity range	(cSt)	2.8 - 380
Fluid temperature range	(°C)	-20 +80
Mass	(kg)	0.220
Hydraulic fluid; mineral oil HM and HV	ISO 6074	
Recommended filtration; 19/15 ISO 4466 (25 μ absolutes)		
Standard seals in Polyurethane and Buna N		

Dimensions

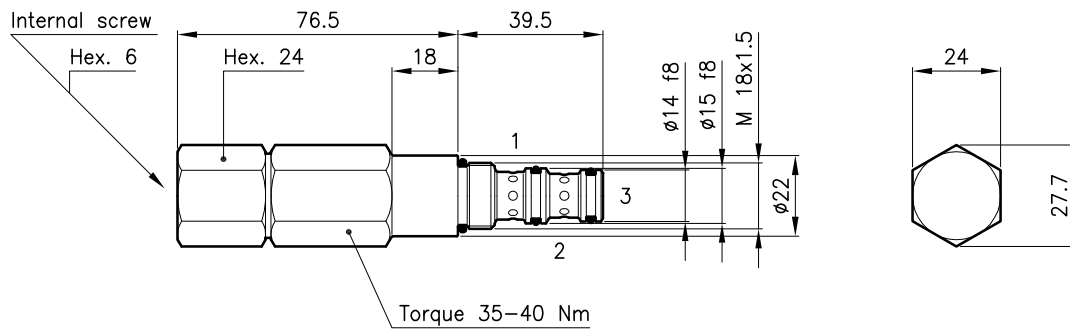

Ordering informations

VDT 20/3203-D-IB

VDT 20 = Valve type

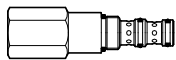

Circuit

3203 =

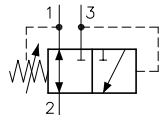

Standard springs

Type	Setting range	Factory set
U	= 20 - 50 bar	35 bar
D	= 35 - 105 bar	70 bar
T	= 70 - 175 bar	120 bar

Adjustment type

IB = Special adjustment

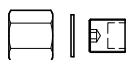

Codes:

VDT 20/3203-U-IB	22 011 136
VDT 20/3203-D-IB	22 011 137
VDT 20/3203-T-IB	22 011 138
External seals kit	90 620 101

VDT 20 valves can be assembled on standard bodies 20-C3 series; for dimensions see catalogue 16.010