

ENGINEERING
TOMORROW



Technical Information

Series 45

Axial Piston Open Circuit Pumps

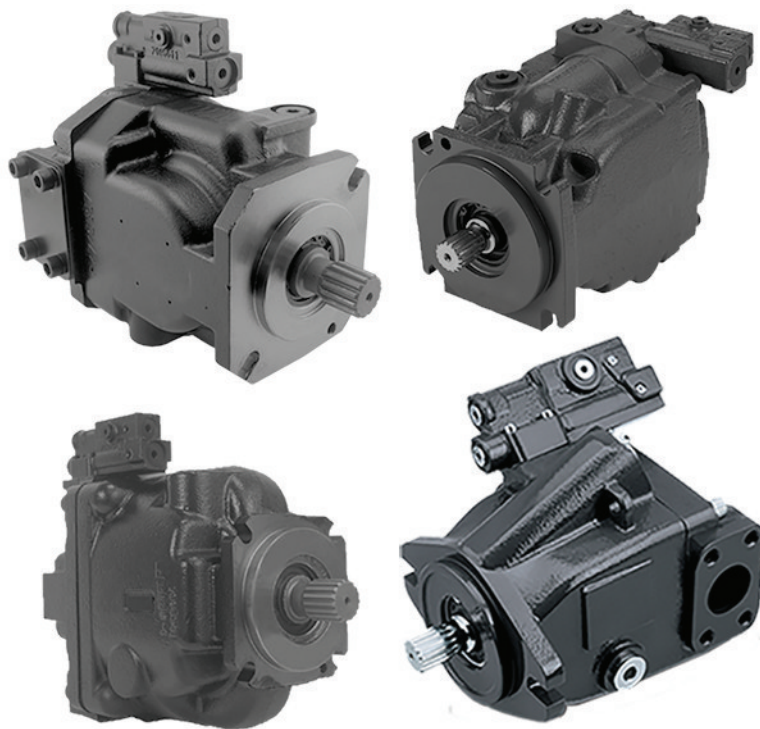

Revision history

Table of revisions

Date	Changed	Rev
September 2017	Corrected performance curves for K2 Pumps	0812
August 2017	Corrected typo	0811
April 2017	Update the TOC	0810
March 2017	add K2 Frame	0809
July 2016	Fan Drive Control configuration-corrected G and H model code tables	0808
July 2016	Fan Drive Control configuration-included G and H model code tables	0807
June 2016	Various edits - Fan Drive Control	0806
April 2016	Various edits - Fan Drive Control	0805
March 2016	Add Fan Drive Control	0804
March 2015	Add E Frame ETL control and Angle Sensor	HC
October 2014	Add ETL control and Angle Sensor	HB
July 2014	Danfoss layout	HA

Contents

General Information

Overview.....	8
Design.....	8
Benefits.....	8
Typical applications.....	9
The Series 45 product family.....	9
Load sensing open circuit system.....	10
Servo Control Orifice.....	11
Servo Control Orifice Principle.....	11
Servo Control Orifice Performance.....	12
Pacing Factor.....	13
Hydraulic Controls.....	13
Pressure compensated controls.....	13
Operation.....	13
Pressure compensated system characteristics.....	14
Typical applications for pressure compensated systems.....	14
Remote pressure compensated controls.....	14
Remote pressure compensated system characteristics.....	15
Typical applications for remote pressure compensated systems.....	16
Load sensing controls.....	16
LS control with bleed orifice.....	16
Integral PC function.....	17
Load sensing system characteristics.....	17
Electric Controls.....	17
Electric Proportional Controls (EPC).....	17
PLUS+1 [®] Compliance.....	17
Electric Proportional Control Principle.....	17
Electric Proportional Control Response/Recovery.....	18
Electric Proportional Control Characteristic – Normally Closed.....	18
Electric Proportional Control Characteristic – Normally Open.....	20
Electric On-Off Controls.....	22
PLUS+1 Compliance.....	22
Electric On-Off Control Principle.....	22
Electric On-Off Control Response/Recovery.....	22
Electric On-Off Control Performance vs. Ambient Temperature Characteristic.....	23
Electric On-Off Control Characteristic – Normally Closed.....	23
Electric On/Off Control Characteristic – Normally Open.....	24
Electric dump valve PC/LS controls.....	25
Electronic Torque Limiting Controls (ETL).....	26
PLUS+1 Compliance.....	26
Electric Torque Limiting Control Principle.....	26
Electronic Torque Limiting Control Characteristic.....	27
Fan Drive Control (FDC).....	28
PLUS+1 Compliance.....	28
Fan Drive Control Principle	28
Fan Drive Control System Characteristics.....	29
Unintended Applications for Fan Drive Control Systems.....	29
Fan Drive Control characteristic - Normally Closed	29
Solenoid data – Normally closed.....	31
Fan Drive Control configuration.....	33
NC Fan Drive Control 3D Views.....	33
Angle Sensor.....	33
PLUS+1 Compliance.....	33
Angle Sensor Principle.....	34
Angle Sensor Characteristics.....	34
J & F-Frame (45-90cc) Angle Sensor Identification Convention:.....	35
E-Frame (100-147cc) Angle Sensor Identification Convention:.....	36
Angle sensor electrical specifications.....	38
Angle Sensor Calibration.....	38

Contents

Angle Sensor Functionality.....	38
Charge Pump Circuits.....	38
Example Circuit #1.....	38
Example Circuit #2.....	39
Operating parameters.....	40
Fluids.....	40
Viscosity.....	40
Temperature.....	40
Inlet pressure.....	41
Case pressure.....	41
Pressure ratings.....	42
Speed ratings.....	42
Duty cycle and pump life.....	42
Speed, flow, and inlet pressure.....	42
Design parameters.....	43
Installation.....	43
Filtration.....	43
Reservoir.....	43
Fluid velocity.....	43
Shaft loads.....	44
Bearing life.....	45
Mounting flange loads.....	45
Estimating overhung load moments.....	45
Auxiliary mounting pads.....	46
Input shaft torque ratings.....	47
Understanding and minimizing system noise.....	47
Understanding and minimizing system instability.....	47
Sizing equations.....	47

Frame K2

Design.....	49
Technical Specifications.....	50
Order Code.....	50
Performance K2-25C.....	56
Performance K2-30C.....	57
Performance K2-38C.....	58
Performance K2-45C.....	59
Hydraulic Controls.....	60
Pressure Compensated Controls.....	60
Remote Pressure Compensated Controls.....	61
Load Sensing Pressure Compensated Controls.....	62
Load Sensing Control with Bleed Orifice /Pressure Compensated.....	63
Electric Controls.....	64
Connectors.....	64
Continuous Duty Operating Range.....	64
Solenoid Data - Normally Closed.....	64
Solenoid Data - Normally Open.....	64
Normally Closed Electric On/Off with Pressure Compensation Controls.....	65
Normally Open Electric On/Off with Pressure Compensation Controls.....	66
Normally Closed Electric Proportional with Pressure Compensation Controls.....	67
Normally Open Electric Proportional with Pressure Compensation Controls.....	68
Normally Closed Fan Drive Control.....	69
Input Shafts.....	70
Installation Drawings.....	72
Axial Ported Endcap.....	72
Axial Ported Endcap Installation Dimensions.....	73
Radial Ported Endcap Split Flange Ports.....	73
Radial Ported Endcap O-ring Boss Ports.....	74
Radial Ported Endcap Installation Dimensions.....	75
Front Mounting Flange - SAE-B two bolt.....	75

Contents

Auxiliary Mounting Pads.....	76
SAE-A auxiliary mounting pad.....	76
SAE-B auxiliary mounting pad.....	76
SAE-A Fixed flange.....	77
Auxiliary Mounting Pad - Running Cover.....	77
Electric solenoid, left side.....	78
Electric solenoid, De-stroking On/Off.....	78
Fan drive control.....	79
Displacement Limiter.....	79

Frames L and K

Design.....	81
Technical Specifications.....	82
Order code.....	82
Performance L25C.....	88
Performance L30D.....	89
Performance K38C.....	90
Performance K45D.....	91
Hydraulic Controls.....	92
Pressure Compensated Controls.....	92
Remote Pressure Compensated Controls.....	92
Load Sensing/Pressure Compensated Controls.....	93
Load Sensing Control with Bleed Orifice /Pressure Compensated.....	94
Electric Controls.....	95
Connector.....	95
Continuous Duty Operating Range.....	96
Solenoid Data - Normally Closed.....	96
Solenoid Data - Normally Open.....	96
Normally Closed Electric On/Off with Pressure Compensation Controls.....	96
Normally Open Electric On/Off with Pressure Compensation Controls.....	97
Normally Closed Electric Proportional Controls with PC and LS Compensation.....	98
Normally Open Electric Proportional Controls with PC and LS Compensation.....	100
Input shafts.....	102
Installation drawings.....	103
Axial Ported Endcap.....	103
Axial Ported Endcap Installation Dimensions.....	104
Radial Ported Endcap Split Flange Ports.....	104
Radial Ported Endcap O-ring Boss Ports.....	105
Radial Ported Endcap Rear View.....	105
Radial Ported Endcap Installation Dimensions.....	106
Front Mounting Flange - SAE-B two bolt.....	106
Auxiliary Mounting Pads.....	107
SAE-A auxiliary mounting pad.....	107
SAE-B auxiliary mounting pad.....	107
Auxiliary Mounting Pad - Running Cover.....	108
Electric Solenoid, Left Side.....	108
Electric Solenoid, Right Side.....	108
Displacement limiter.....	109

Frame J

Design.....	110
Technical Specifications.....	111
Order code.....	111
Performance J45B.....	121
Performance J51B.....	122
Performance J60B.....	123
Performance J65C.....	124
Performance J75C.....	125
Hydraulic Controls.....	126
Pressure Compensated Controls.....	126

Contents

Remote Pressure Compensated Controls.....	127
Load sensing/Pressure compensated Controls.....	128
Load sensing Control with Bleed Orifice/ Pressure Compensated.....	129
Electric Controls.....	130
Connectors.....	130
Continuous Duty Operating Range.....	130
Solenoid Data - Normally Closed.....	130
Solenoid Data - Normally Open.....	130
Fan Drive Control Solenoid Data - Normally Closed.....	131
Normally Closed Electric On/Off with Pressure Compensation Controls.....	131
Normally Open Electric On/Off with Pressure Compensation Controls.....	132
Normally Closed Electric Proportional with Pressure Compensation Controls.....	133
Normally Open Electric Proportional with Pressure Compensation Controls.....	134
Normally Closed Electric Torque Limiting Control with Pressure Compensation Controls.....	136
Normally Closed Fan Drive Control	137
Input shafts.....	138
Installation drawings.....	141
Axial Ported Endcap.....	141
Axial Ported Endcap Installation Dimensions.....	142
Right Fan Drive Control.....	143
Radial Ported Endcap Split Flange Ports.....	143
Radial Ported Endcap Rear View.....	144
Radial Ported Endcap Installation Dimensions.....	145
Right Angle Sensor Position Installation Dimensions.....	146
Front Mounting Flange.....	147
Auxiliary mounting pads.....	148
SAE-A auxiliary mounting pad (integrated).....	148
SAE-A auxiliary mounting pad (non-integral).....	149
SAE-B auxiliary mounting pad.....	150
SAE-C auxiliary mounting pad.....	150
Running cover.....	151
Radial Endcap Clockwise.....	151
Radial Endcap Counterclockwise.....	152
Axial Endcap Clockwise.....	153
Axial Endcap Counterclockwise.....	153
Displacement limiter.....	153

Frame F

Design.....	155
Technical Specifications.....	156
Order code.....	156
Performance F74B.....	162
Performance F90C.....	163
Hydraulic Controls.....	164
Pressure Compensated Controls.....	164
Remote Pressure Compensated Controls.....	164
Load Sensing/Pressure Compensated Controls.....	165
Load Sensing Control with Bleed Orifice/Pressure Compensated.....	166
Electric Controls.....	167
Connectors.....	167
Continuous Duty Operating Range.....	168
Solenoid Data - Normally Closed.....	168
Solenoid Data - Normally Open.....	168
Fan Drive Control Solenoid Data - Normally Closed.....	168
Normally Closed Electric On/Off with Pressure Compensation Controls.....	168
Normally Open Electric On/Off with Pressure Compensation Controls.....	169
Normally Closed Electric Proportional with Pressure Compensation Controls.....	170
Normally Open Electric Proportional with Pressure Compensation Controls.....	171
Normally Closed Electric Torque Limiting Control with Pressure Compensation Controls.....	173
Normally Closed Fan Drive Control.....	174

Contents

Input shafts.....	175
Installation drawings.....	176
Axial Ported Endcap.....	176
Axial Ported Endcap Installation Dimensions.....	176
Right Fan Drive Control.....	177
Radial Ported Endcap Split Flange Ports.....	177
Radial Ported Endcap Rear View.....	178
Radial Ported Endcap Installation Dimensions.....	179
Right Angle Sensor Position Installation Dimensions.....	180
Front Mounting Flange.....	181
Radial Endcap Clockwise.....	183
Radial Endcap Counterclockwise.....	184
Axial Endcap Clockwise.....	184
Axial Endcap Counterclockwise.....	184
Displacement limiter.....	184

Frame E

Design.....	186
Technical Specifications.....	187
Order code.....	187
Performance E100B.....	194
Performance E130B.....	195
Performance E147C.....	196
Hydraulic Controls.....	197
Pressure Compensated Controls.....	197
Remote Pressure Compensated Controls.....	197
Load Sensing/Pressure Compensated.....	198
Load Sensing Control with Bleed Orifice/Pressure Compensated.....	199
Electric Controls.....	200
Connectors.....	200
Continuous Duty Operating Range.....	201
Solenoid Data - Normally Closed.....	201
Solenoid Data - Normally Open.....	201
Normally Closed Electric On/Off with Pressure Compensation Controls.....	201
Normally Open Electric On/Off with Pressure Compensation Controls.....	202
Normally Closed Electric Proportional with Pressure Compensation Controls.....	203
Normally Open Electric Proportional with Pressure Compensation Controls.....	205
Normally Closed Electric Torque Limiting Control with Pressure Compensation Controls.....	206
Input shafts.....	208
Installation drawings.....	209
Axial Ported Endcap.....	209
Axial Ported Endcap Installation Dimensions.....	210
Radial Ported Endcap Installation Dimensions.....	211
Right Angle Sensor Position Installation Dimensions.....	212
Radial Ported Endcap Rear View.....	213
Radial Ported Endcap Split Flange Ports.....	213
Front Mounting Flange.....	214
Endcap Dimensions.....	215
Auxiliary mounting pads.....	216
Displacement Limiters.....	218

General Information

Overview

Series 45 is a complete family of high performance variable displacement, axial piston pumps. Each frame is designed to exceed the demanding work function requirements of the mobile equipment marketplace. Each frame within the Series 45 family is uniquely designed to optimize performance, size, and cost.

Design

High Performance

- Displacements from 25 cm³ - 147 cm³ [1.53 - 8.97 in³/rev]
- Speeds up to 3600 rpm
- Pressures up to 310 bar [4495 psi]
- Variety of control system options including load sensing and pressure compensated

Latest Technology

- Customer-driven using quality function deployment (QFD) and design for manufacturability (DFM) techniques
- Optimized design maximizes efficiency and quiet operation
- Computer-modeled castings to optimize inlet conditions for maximum pump speed
- Compact package size minimizing installation space requirements
- Heavy-duty tapered roller bearings for long life
- Single piece rigid housing to reduce noise and leak paths
- Integrated controls for high speed response and system stability

Reliability

- Designed to rigorous standards
- Proven in both laboratory and field
- Manufactured to rigid quality standards
- Long service life
- Significantly fewer parts
- No gasket joints
- Robust input shaft bearings to handle large external shaft loads
- Integrated gauge ports for monitoring operating conditions

Benefits

Reduced Installation Costs

- Through-drive capability for multi-circuit systems
- Range of mounting flanges, shafts and porting options for ease of installation
- Compact size minimizes installation space requirements
- Help meet engine emission standards
- Reduce engine size by managing power usage more effectively

Reduce Operating Costs

- Optimize machine power usage to maximize fuel economy
- Simple design reduces service requirements
- Heavy duty taper roller shaft bearings provide long service life

General Information

Increased Customer Satisfaction

- Reduced noise for operator comfort
- High performance increases productivity

Reduced Heat Load on Cooling System

- High efficiency reduces hydraulic heat generation
- Allows for smaller cooling packages

Typical applications

- Cranes
- Telescopic handlers
- Forklift trucks
- Wheel loaders
- Sweepers
- Backhoe loaders
- Forestry and agricultural machinery
- Fan drives
- Paving Machines
- Mining Equipment
- Mowers
- Dozers
- Drilling Machines
- Mini-Excavators
- Other Applications

The Series 45 product family

Basic units

The series 45 family of open circuit, variable piston pumps, offers a range of displacements from 25 to 147 cm³/rev [1.53 to 8.97 in³/rev]. With maximum speeds up to 3600 rpm and continuous operating pressures up to 310 bar [4495 psi], product selection is easily tailored to the flow and pressure requirements of individual applications.

K2 Frame

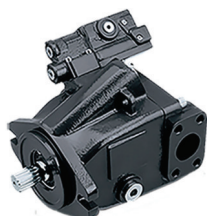

J Frame



F Frame

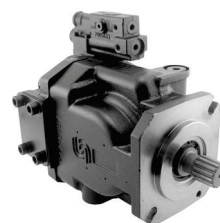

E Frame



General Information

General performance specifications for the series 45 pump family

Pump		Displacement		Speed			Pressure				Theoretical flow (at rated speed)		Mounting
				Continuous	Max.	Min.	Cont.		Max.				
Frame	Model	cm ³	in ³	min-1 (rpm)	min-1 (rpm)	min-1 (rpm)	bar	psi	bar	psi	US gal/min	l/min	Flange
Frame L	L25C	25	1.53	3200	3600	500	260	3770	350	5075	21.0	80.0	SAE B - 2 bolt
	L30D	30	1.83	3200	3600	500	210	3045	300	4350	25.4	96.0	SAE B - 2 bolt
Frame K	K38C	38	2.32	2650	2800	500	260	3770	350	5075	26.6	100.7	SAE B - 2 bolt
	K45D	45	2.75	2650	2800	500	210	3045	300	4350	31.5	119.3	SAE B - 2 bolt
Frame K2 on page 49	K2-25C	25	1.53	3450	3750	500	260	3771	350	5076	22.0	84.2	SAE B - 2 bolt
	K2-30C	30	1.83	3200	3450	500					25.4	96.0	SAE B - 2 bolt
	K2-38C	38	2.32	2900	3050	500					28.1	106.4	SAE B - 2 bolt
	K2-45C	45	2.75	2900	3050	500					33.28	126.0	SAE B - 2 bolt
Frame J	J45B	45	2.75	2900	3360	500	310	4495	400	5800	33.3	126.0	SAE B 2-bolt SAE C 2 and 4-bolt
	J51B	51	3.11	2700	3240	500	310	4495	400	5800	36.4	137.7	SAE B 2-bolt SAE C 2 and 4-bolt
	J60B	60	3.66	2600	3120	500	310	4495	400	5800	41.2	156.0	SAE B 2-bolt SAE C 2 and 4-bolt
	J65C	65	3.97	2500	3000	500	260	3770	350	5075	42.9	162.6	SAE B 2-bolt SAE C 2 and 4-bolt
	J75C	75	4.58	2400	2880	500	260	3770	350	5075	47.5	180.0	SAE B 2-bolt SAE C 2 and 4-bolt
Frame F	F74B	74	4.52	2400	2800	500	310	4495	400	5800	46.9	177.6	SAE B 2-bolt SAE C 4-bolt
	F90C	90	5.49	2200	2600	500	260	3770	350	5075	52.3	198	SAE B 2-bolt SAE C 4-bol
Frame E	E100B	100	6.10	2450	2880	500	310	4495	400	5800	64.7	245.0	SAE C 4-bolt
	E130B	130	7.93	2200	2600	500	310	4495	400	5800	75.5	286.0	SAE C 4-bolt
	E147C	147	8.97	2100	2475	500	260	3770	350	5075	81.5	308.7	SAE C 4-bolt

Load sensing open circuit system

The pump receives fluid directly from the reservoir through the inlet line. A screen in the inlet line protects the pump from large contaminants. The pump outlet feeds directional control valves such as PVG-32's, hydraulic integrated circuits (HIC), and other types of control valves. The PVG valve directs pump flow to cylinders, motors and other work functions. A heat exchanger cools the fluid returning from the valve. A filter cleans the fluid before it returns to the reservoir.

Flow in the circuit determines the speed of the actuators. The position of the PVG valve determines the flow demand. A hydraulic pressure signal (LS signal) communicates demand to the pump control. The pump control monitors the pressure differential between pump outlet and the LS signal, and regulates servo pressure to control the swashplate angle. Swashplate angle determines pump flow.

Actuator load determines system pressure. The pump control monitors system pressure and will decrease the swashplate angle to reduce flow if system pressure reaches the PC setting. A secondary system relief valve in the PVG valve acts as a back-up to control system pressure.

General Information

Pictorial circuit diagram

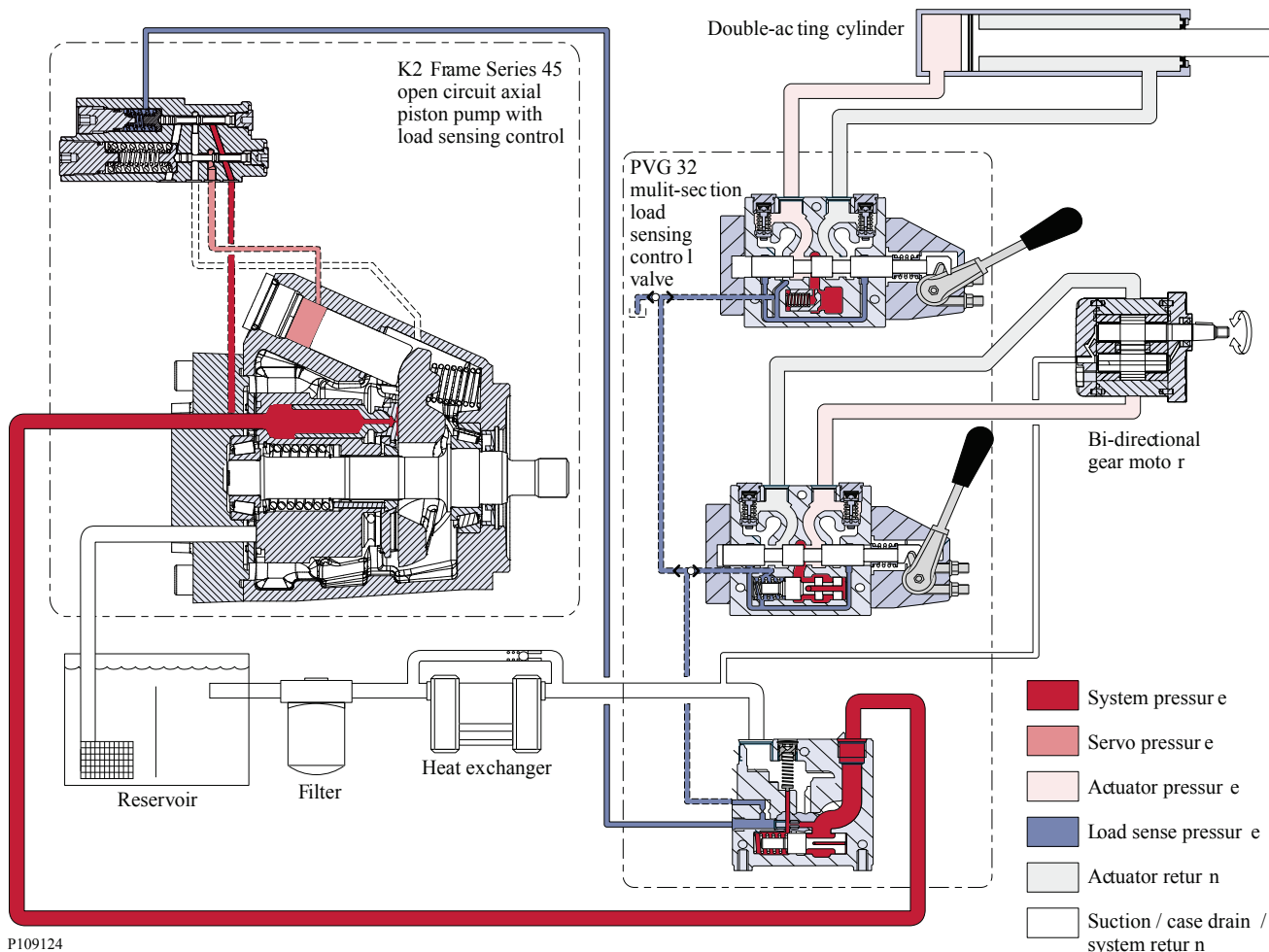

P109124

Servo Control Orifice

Servo Control Orifice Principle

Series 45 controls offer an optional servo control orifice (not available with Pressure Compensation only Controls) available to aid in tuning system performance. The optional servo control orifice restricts flow to and from the servo system in the pump, effectively pacing the motion of the servo system.

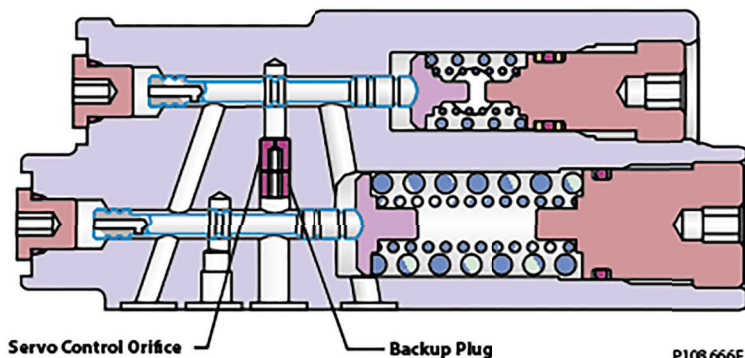

P108666E

General Information

Servo Control Orifice Performance

The use of the Servo Control Orifice will provide additional pacing to the pump, while the response of the pump to pressure spikes remains unaffected. The Pressure Compensation Function response and recovery, as well as the Load Sense Function response and recovery are shown below, and outline the relative impact in response and recovery of the Servo Control Orifices. Note that these graphs are meant as a generic comparison only, and that unique effects on response and recovery behavior for each specific frame are shown later in this section.

**Relative Servo Control Orifice Performance
 Generic PC Response and Recovery**

Input Speed=1800rpm, Temperature=49°C, PC Setting=210Bar, LS Setting=20Bar

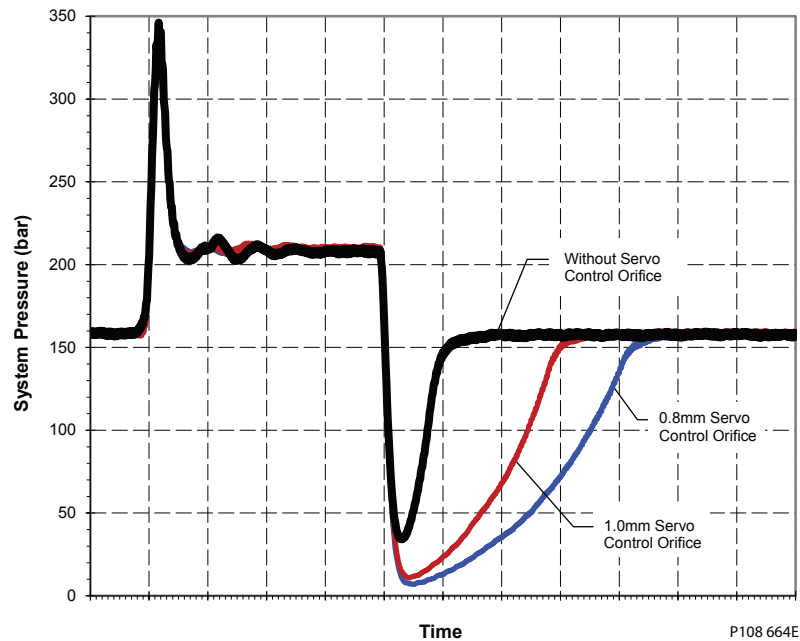

P108 664E

**Relative Servo Control Orifice Performance
 Generic LS Response and Recovery**

Input Speed = 1800rpm, Temperature=49 C, PC Setting=310Bar, LS Setting=30Bar

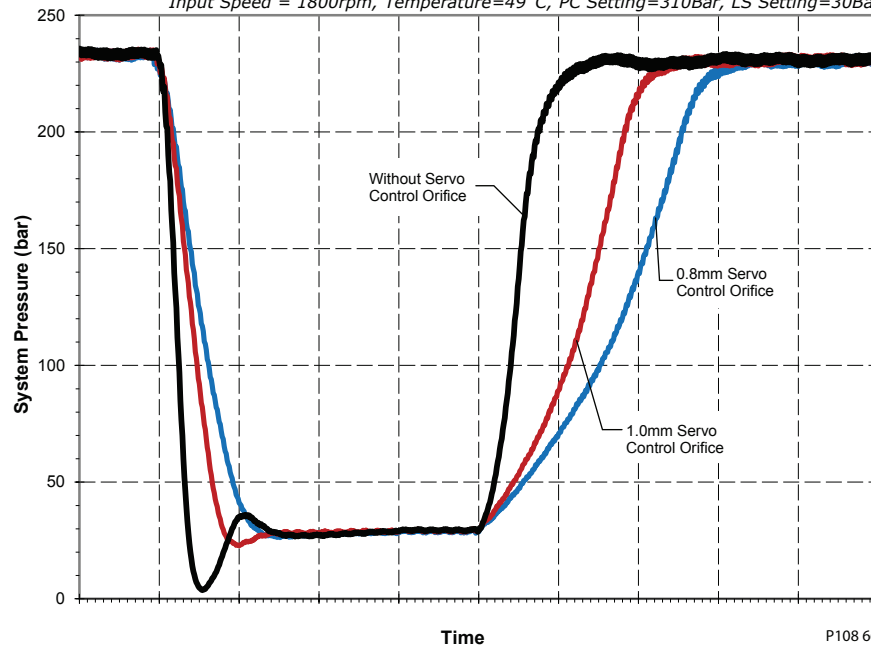

P108 665E

General Information

We recommend that systems experiencing instability use a Servo Control Orifice. Start with the largest size orifice available, and work down to the smaller size until the system is satisfactorily tuned. All Fan-Drive systems should start with a 0.8mm Servo Control Orifice if possible. Systems including motors are more likely to require the Servo Control Orifice option.

Pacing Factor

Use of a Servo Control Orifice adds a pacing factor to each Series 45 Frame, impacting the behavior of the pumps reactivity. This pacing factor can be multiplied by the specific Frame/Displacement/Control selection's response and recovery times, to determine the final paced response and recovery times. Unique response and recovery times can be found in each frame-specific chapter, in the desired control section. The paced response and recovery relationship is shown below.

Response (Damped)= Response (Specific Disp.Control) *Pacing Factor

Recovery (Damped)= Recovery (Specific Disp.Control) *Pacing Factor

Pacing Factors are unique to each orifice size, and can impact each frame differently. Below are the Pacing Factors for each Servo Control Orifice Size by frame.

Frame	Pacing Factors - Servo Control Orifice							
	1.0 mm Servo Control Orifice				0.8 mm Servo Control Orifice			
	PC Response	PC Recovery	LS Response	LS Recovery	PC Response	PC Recovery	LS Response	LS Recovery
E-Frame*	1 (No Effect)	2.3	2.0	2.0	1 (No Effect)	3.2	2.6	2.6
F-Frame*		2.3	2.0	2.0		3.2	2.6	2.6
J-Frame*		2.3	2.0	2.0		3.2	2.6	2.6
K2-Frame		2.3	2.0	2.0		3.2	2.6	2.6
K-Frame**		2.3	2.3	2.3		3.7	3.1	3.1
L-Frame**		2.3	2.3	2.3		3.7	3.1	3.1

* PC Response from 160 bar to 210 bar, PC Recovery from 210 bar to 160 bar at 1800 rpm; LS Response from 230 bar to 30 bar, LS Recovery from 30 bar to 230 bar at 1800 rpm.

** ** PC Response from 160 bar to 210 bar, PC Recovery from 210 bar to 160 bar at 1800 rpm; LS Response from 160 bar to 20 bar, LS Recovery from 20 bar to 160 bar at 1800 rpm.

Hydraulic Controls

Pressure compensated controls

Operation

The PC control maintains constant system pressure in the hydraulic circuit by varying the output flow of the pump. Used with a closed center control valve, the pump remains in high pressure standby mode at the PC setting with zero flow until the function is actuated. This condition is often called a **dead head** condition.

Typical operating curve

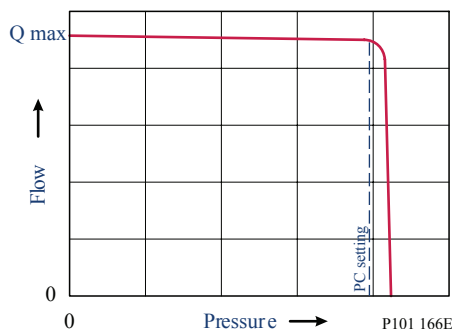

General Information

Simple closed-center circuit

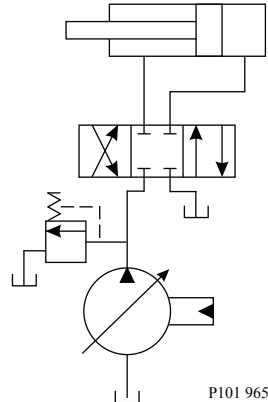

Once the closed center valve is opened, the PC control senses the immediate drop in system pressure and increases pump flow by increasing the swashplate angle. The pump continues to increase flow until system pressure reaches the PC setting. If system pressure exceeds the PC setting, the PC control reduces the swashplate angle to maintain system pressure by reducing flow. The PC control continues to monitor system pressure and changes swashplate angle to match the output flow with the work function pressure requirements.

If the demand for flow exceeds the capacity of the pump, the PC control directs the pump to maximum displacement. In this condition, actual system pressure depends on the actuator load.

Each section includes control schematic diagrams, setting ranges, and response / recovery times for each control available. *Response* is the time (in milliseconds) for the pump to reach zero displacement when commanded by the control. *Recovery* is the time (in milliseconds) for the pump to reach full displacement when commanded by the control. Actual times can vary depending on application conditions.

It is recommended that a relief valve be installed in the pump outlet for additional system protection

Pressure compensated system characteristics

- Constant pressure and variable flow
- High pressure standby mode when flow is not needed
- System flow adjusts to meet system requirements
- Single pump can provide flow to multiple work functions
- Quick response to system flow and pressure requirements

Typical applications for pressure compensated systems

- Constant force cylinders (bailers, compactors, refuse trucks)
- On/off fan drives
- Drill rigs
- Sweepers
- Trenchers

Remote pressure compensated controls

The remote PC control is a two-stage control that allows multiple PC settings. Remote PC controls are commonly used in applications requiring low and high pressure PC operation.

General Information

Typical operating curve

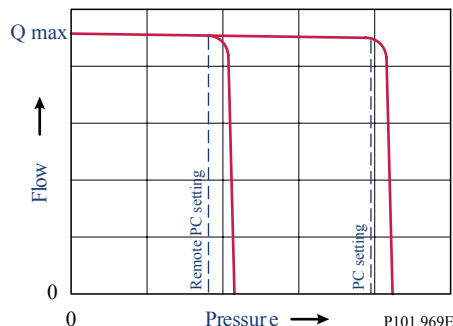

Closed center circuit with remote PC

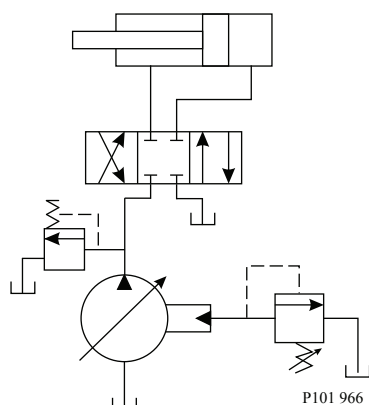

The remote PC control uses a pilot line connected to an external hydraulic valve. The external valve changes pressure in the pilot line, causing the PC control to operate at a lower pressure. When the pilot line is vented to reservoir, the pump maintains pressure at the load sense setting. When pilot flow is blocked, the pump maintains pressure at the PC setting. An on-off solenoid valve can be used in the pilot line to create a low-pressure standby mode. A proportional solenoid valve, coupled with a microprocessor control, can produce an infinite range of operating pressures between the low pressure standby setting and the PC setting.

It is recommended that a relief valve be installed in the pump outlet for additional system protection.

Each section includes control schematic diagrams, setting ranges, and response / recovery times for each control available. *Response* is the time (in milliseconds) for the pump to reach zero displacement when commanded by the control. *Recovery* is the time (in milliseconds) for the pump to reach full displacement when commanded by the control. Actual times can vary depending on application conditions.

Size the external valve and plumbing for a pilot flow of 3.8 l/min [1 US gal/min].

Remote pressure compensated system characteristics

- Constant pressure and variable flow
- High or low pressure standby mode when flow is not needed
- System flow adjusts to meet system requirements
- Single pump can provide flow to multiple work functions
- Quick response to system flow and pressure requirements

General Information

Typical applications for remote pressure compensated systems

- Modulating fan drives
- Anti-stall control with engine speed feedback
- Front wheel assist
- Road rollers
- Combine harvesters
- Wood chippers

Load sensing controls

Operation

The LS control matches system requirements for both pressure and flow in the circuit regardless of the working pressure. Used with a closed center control valve, the pump remains in low-pressure standby mode with zero flow until the valve is opened. The LS setting determines standby pressure.

Typical operating curve

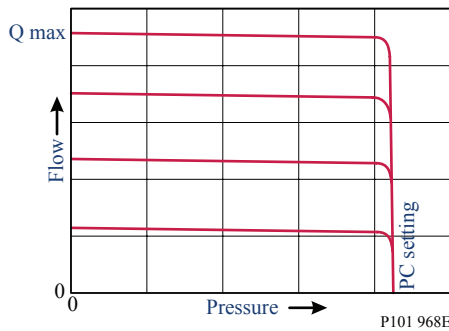

Load sensing circuit

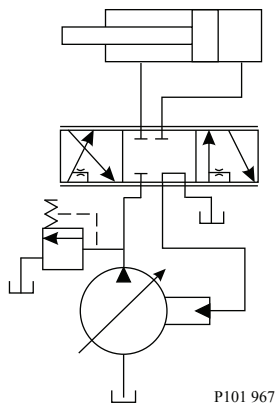

Most load sensing systems use parallel, closed center, control valves with special porting that allows the highest work function pressure (LS signal) to feed back to the LS control. Margin pressure is the difference between system pressure and the LS signal pressure. The LS control monitors margin pressure to read system demand. A drop in margin pressure means the system needs more flow. A rise in margin pressure tells the LS control to decrease flow.

LS control with bleed orifice

The load sense signal line requires a bleed orifice to prevent high-pressure lockup of the pump control. Most load-sensing control valves include this orifice. An optional internal bleed orifice is available, for use with control valves that do not internally bleed the LS signal to tank.

General Information

Integral PC function

The LS control also performs as a PC control, decreasing pump flow when system pressure reaches the PC setting. The pressure compensating function has priority over the load sensing function.

For additional system protection, install a relief valve in the pump outlet line.

Load sensing system characteristics

- Variable pressure and flow
- Low pressure standby mode when flow is not needed
- System flow adjusted to meet system requirements
- Lower torque requirements during engine start-up
- Single pump can supply flow and regulate pressure for multiple circuits
- Quick response to system flow and pressure requirements

Electric Controls

Electric Proportional Controls (EPC)

PLUS+1° Compliance

All Series 45 Electric controls have met and passed the Danfoss PLUS+1° compliance standard testing, and as such, this Series 45 control is PLUS+1° compliant. PLUS+1° compliance blocks are available on the Danfoss website, within the PLUS+1° Guide section.

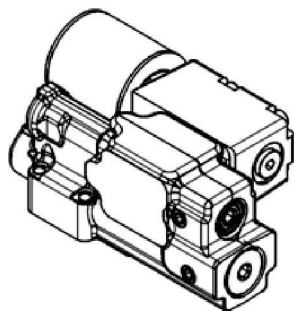

Electric Proportional Control Principle

The Electric Proportional Control consists of a proportional solenoid integrated into a Remote Pressure Compensated control. This control allows the pump to be operated at any pressure limit between the Load Sense and Pressure Compensation settings by varying the current sent to the solenoid.

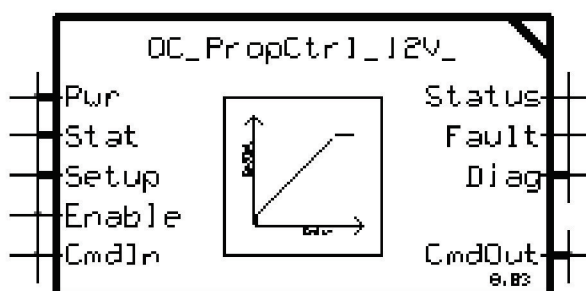

General Information

Reference individual frame sections for the margin (LS) setting vs low pressure standby relationship.

Electric proportional controls have a unique relationship between margin (LS) setting and low pressure standby. This relationship is available in the electric proportional controls section for each frame.

For fan-drive systems, and systems with motors, use a minimum 15bar LS setting to enhance system stability. As the LS setting is reduced, the risk for system instability may be increased. A 20bar LS setting is recommended as a starting point for all new applications.

Electric Proportional Control Response/Recovery

S45 Electric Proportional Controls require the use of a servo control orifice, and are available with two possible servo control orifice options. The servo control orifice is used to enhance system stability, as well as dampen the pump reactivity. A smaller orifice diameter will add dampening to the pump reactivity, while a larger orifice will allow quicker pump reaction. Fan-Drive applications, as well as systems with the pump supplying motors, are recommended to use the 0.8mm diameter orifice to enhance system stability.

Module "G" Options for Electric Proportional Controls		
Frame	"E" - 0.8mm Orifice	"F" - 1.0mm Orifice
All Frames	•	•

Specific Electric Proportional Control Response/Recovery times are shown for the available servo control orifice options in the control section within each specific frame section. These times represent the response from 100bar to 200bar, and recovery from 200bar to 100bar. As the upper pressure approaches the PC setting, the PC function will begin to assist in clipping pressure overshoots during the pump's response, and will decrease the response times of the pump to equal those of the PC response.

Electric Proportional Control Pressure vs. Flow Characteristic

The Electric Proportional Controls continuous duty operating temperature range is shown below; this guideline should be followed as well as the maximum current limitations. Note that rated voltage refers to either a 12V or 24V coil. Under high temperature conditions, current required to operate the solenoid increases.

Continuous Duty Operating Temperature

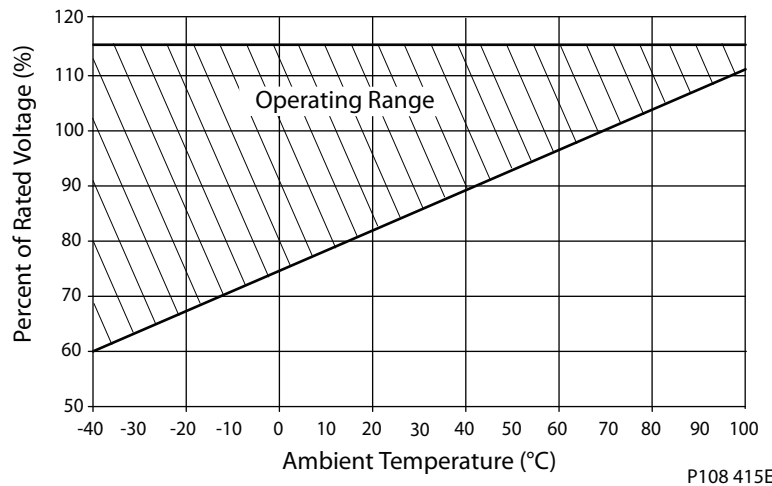

Electric Proportional Control Characteristic – Normally Closed

When an electric current is sent to the Normally Closed configuration control, the pump pressure decreases proportional to an increase in current. When the load in the system changes, the pump will

General Information

adjust its displacement to maintain the pressure demanded by the controlling current. This control is especially useful for fan-drives, due to the direct relationship between fan-speed and pump pressure.

Due to the nature of Electric Proportional Controls, the relationship between current and pump pressure is unique for each individual PC/LS pressure setting combination. The relationship between different PC settings and different LS settings on the Pressure vs. Current Characteristic curve are shown below. The hydraulic schematic for the Normally Closed Electric Proportional control is shown below as well.

Operating Pressure vs. Input Current (N.C. EPC)

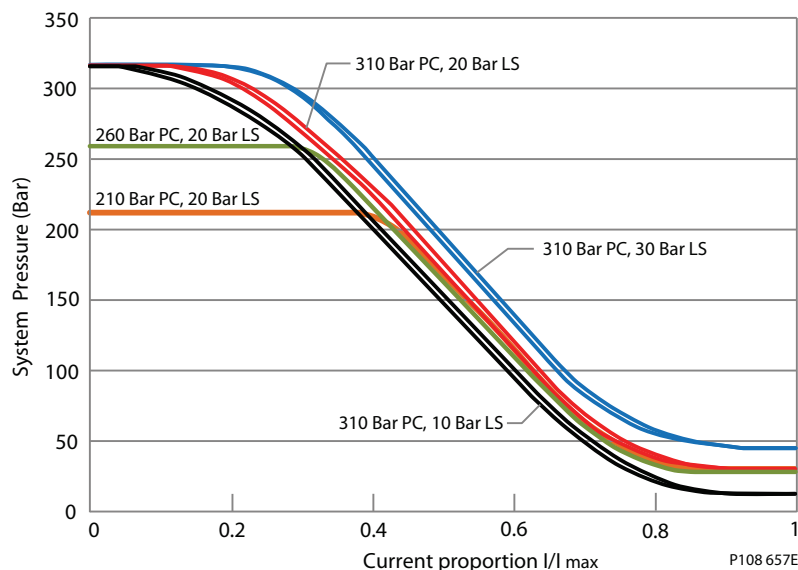

Solenoid Data – Normally Closed

Voltage	12V	24V
Maximum Current	1800 mA	920 mA
Inrush Current	1700 mA	800 mA
Coil Resistance @ 20°C [70°F]	7.1 Ω	28.5 Ω
PWM Range	200-300 Hz	
PWM Frequency (preferred)	250 Hz	
IP Rating (IEC 60529 DIN 40050-9)	IP67	IP67
IP Rating (IEC 60529 DIN 40050-9) with mating connector	IP69K	IP69K
Operating Temperature	Consistent with Pump Limits: -40°C (-40°F) to 104°C (220°F)	

The available Normally Closed Electric Proportional Controls for the Series 45 are shown below. The allowable Pressure Compensator (PC) and Load Sense (LS) pressure settings are provided for each frame in their respective sections.

Electric Proportional Controls Options – Normally Closed		Frame					
Code	Description	L	K	K2	J	F	E
AH	Electric Proportional Pressure Control w/Pressure Comp. (NC, 12VDC) Left			•	•	•	•
AL	Electric Proportional Pressure Control w/Pressure Comp. (NC, 24VDC) Left			•	•	•	•
AV	Electric Proportional Pressure Control w/Pressure Comp. (NC, 12VDC) Right				•	•	•

General Information

Electric Proportional Controls Options – Normally Closed		Frame					
AK	Electric Proportional Pressure Control w/Pressure Comp. (NC, 24VDC) Right				•	•	•
BH	Electric Proportional Pressure Control w/Pressure Comp. (NC, 12VDC) [>280 bar] Left				•	•	•
BL	Electric Proportional Pressure Control w/Pressure Comp. (NC, 24VDC) [>280 bar] Left				•	•	•
BM	Electric Proportional Pressure Control w/Pressure Comp. (NC, 12VDC) [>280 bar] Right				•	•	•
BK	Electric Proportional Pressure Control w/Pressure Comp. (NC, 24VDC) [>280 bar] Right				•	•	•
EM	Electric Proportional Pressure Control w/Pressure Comp. (NC, 12VDC)	•	•				
EN	Electric Proportional Pressure Control w/Pressure Comp. (NC, 24VDC)	•	•				

Notes:

1. Left = E-Frame: CW Only, F-Frame: CW Only, J-frame: CW Axial, CCW Radial
2. Right = E-Frame: CCW Only, F-Frame: CCW Only, J-frame: CCW Axial, CW Radial
3. K/L Frame Controls are not rotation dependent
4. K2 Frame electric controls are limited only for Left orientation and up to 260 Bar

Electric Proportional Control Characteristic – Normally Open

When an electric current is sent to the normally open configuration control, the pump pressure increases proportional to an increase in current. When the load in the system changes, the pump will adjust its displacement to maintain the pressure demanded by the controlling current. This control is especially useful for fan-drives, due to the direct relationship between fan-speed and pump pressure.

Due to the nature of Electric Proportional Controls, the relationship between current and pump pressure is unique for each individual PC/LS pressure setting combination. The relationship between different PC settings and different LS settings on the Pressure vs. Current Characteristic curve are shown below. The hydraulic schematic for the Normally Open Electric Proportional control is shown below as well.

Operating Pressure vs. Input Current (N.O. EPC)

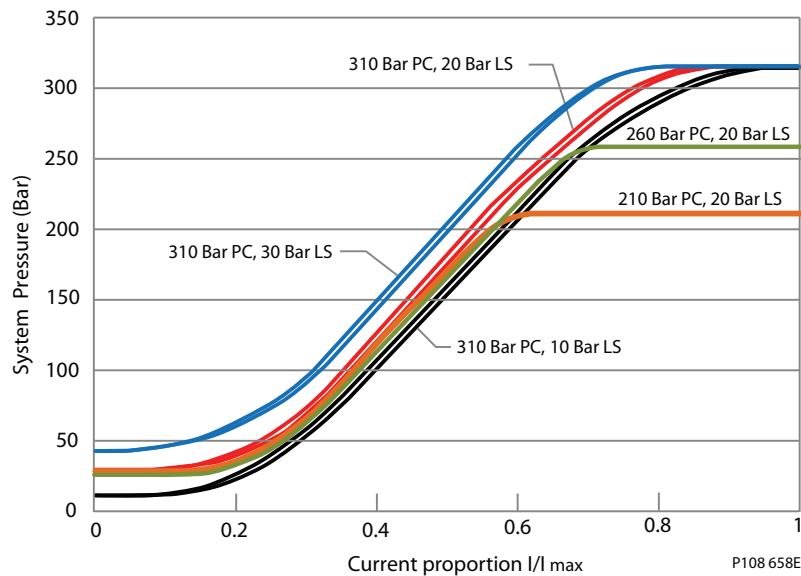

General Information

Solenoid Data – Normally Open

Voltage	12V	24V
Maximum Current	1500 mA	665 mA
Inrush Current	1700 mA	800 mA
Coil Resistance @ 20°C [70°F]	7.1 Ω	28.5 Ω
PWM Range	200-300 Hz	
PWM Frequency (preferred)	250 Hz	
IP Rating (IEC 60529 DIN 40050-9)	IP67	IP67
IP Rating (IEC 60529 DIN 40050-9) with mating connector	IP69K	IP69K
Operating Temperature	Consistent with Pump Limits: -40°C (-40°F) to 104°C (220°F)	

The available Normally Open Electric Proportional Controls for the Series 45 are shown below. The allowable Pressure Compensator (PC) and Load Sense (LS) pressure settings are provided for each frame in their respective sections. Note that for Electric Proportional Controls, the Load Sense setting describes the Low Pressure Standby value, not margin.

Electric Proportional Controls Options – Normally Open		Frame					
Code	Description	L	K	K2	J	F	E
AX	Electric Proportional Pressure Control w/Pressure Comp. (NO, 12VDC) Left			•	•	•	•
CL	Electric Proportional Pressure Control w/Pressure Comp. (NO, 24VDC) Left			•	•	•	•
AW	Electric Proportional Pressure Control w/Pressure Comp. (NO, 12VDC) Right				•	•	•
CK	Electric Proportional Pressure Control w/Pressure Comp. (NO, 24VDC) Right				•	•	•
BX	Electric Proportional Pressure Control w/Pressure Comp. (NO, 12VDC) [>280 bar] Left				•	•	•
DL	Electric Proportional Pressure Control w/Pressure Comp. (NO, 24VDC) [>280 bar] Left				•	•	•
BW	Electric Proportional Pressure Control w/Pressure Comp. (NO, 12VDC) [>280 bar] Right				•	•	•
DK	Electric Proportional Pressure Control w/Pressure Comp. (NO, 24VDC) [>280 bar] Right				•	•	•
EK	Electric Proportional Pressure Control w/Pressure Comp. (NO, 12VDC)	•	•				
EL	Electric Proportional Pressure Control w/Pressure Comp. (NO, 24VDC)	•	•				

Notes:

1. Left = E-Frame: CW Only, F-Frame: CW Only, J-frame: CW Axial, CCW Radial
2. Right = E-Frame: CCW Only, F-Frame: CCW Only, J-frame: CCW Axial, CW Radial
3. K/L Frame Controls are not rotation dependent
4. K2 Frame electric controls are limited only for Left orientation and up to 260 Bar

General Information

Electric On-Off Controls

PLUS+1 Compliance

All Series 45 Electric controls have met and passed the Danfoss PLUS+1 compliance standard testing, and as such, this Series 45 control is PLUS+1 compliant. PLUS+1 compliance blocks are available on the Danfoss website, within the PLUS+1 Guide section.

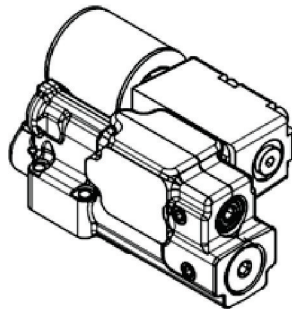

Electric On-Off Control Principle

The Electric On/Off Control consists of an On/Off solenoid integrated into a Remote Pressure Compensated control. This control allows the pump to be operated at either the Load Sense pressure setting when "On", or the Pressure Compensation pressure setting when "Off".

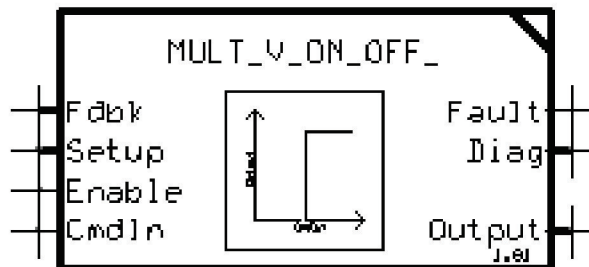

For fan-drive systems, and systems with motors, use a minimum 15bar LS setting to enhance system stability. As the LS setting is reduced, the risk for system instability may be increased. A 20bar LS setting is recommended as a starting point for all new applications.

Electric On-Off Control Response/Recovery

S45 Electric On/Off Controls are available with two servo control orifice options, as well as without an orifice. The servo control orifice is used to enhance system stability, as well as dampen the pump reactivity. A smaller orifice diameter will add dampening to the pump reactivity, while a larger orifice will allow quicker pump reaction.

Module "G" Options for Electric On/Off Controls			
Frame	"E" - 0.8mm Orifice	"F" - 1.0mm Orifice	"N" - No Orifice
All Frames	•	•	•

Specific Electric On/Off Control Response/Recovery times are shown for the available servo control orifice options in the control section within each specific frame section. These times represent the response

General Information

from 75% of rated continuous pressure to 100% of rated continuous pressure, and recovery from 100% of rated continuous pressure to 75% of rated continuous pressure for N.C. configuration per SAE J745 (vice-versa for N.O). As the system pressure approaches the PC setting, the PC function will begin to assist in clipping pressure overshoots during the pump’s response, and will decrease the response times of the pump to equal those of the PC response.

Electric On-Off Control Performance vs. Ambient Temperature Characteristic

The Electric On/Off Controls continuous duty operating temperature range is shown below; this guideline should be followed as well as the maximum current limitations. Note that rated voltage refers to either a 12V or 24V coil. Under high temperature conditions, current required to operate the solenoid increases.

Continuous Duty Operating Temperature

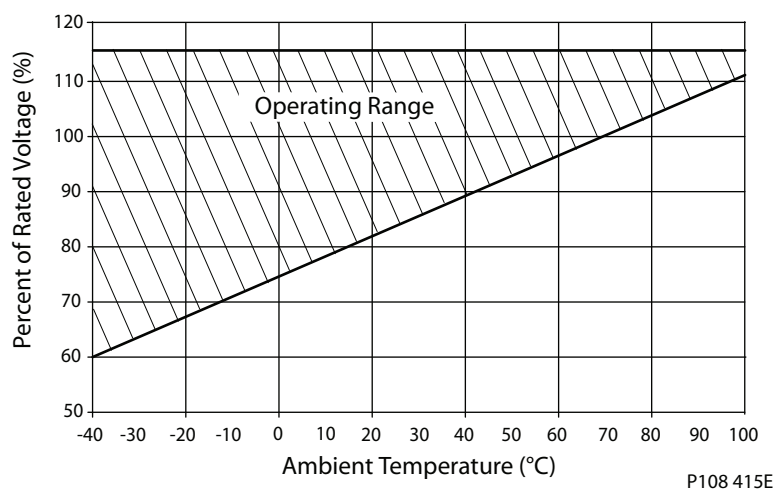

Electric On-Off Control Characteristic – Normally Closed

The normally closed configuration On/Off control directs the pump to its Pressure Compensation pressure setting when no current is applied. When the required electric current is sent to the normally closed configuration control the pump pressure decreases to the Low-Pressure Standby setting. This control does not have Load Sense functionality, but rather acts as a Pressure Compensation control when not energized, or is directed to its low-pressure standby when energized. This control is especially useful for machine startups, as the pump can be directed to its Low-Pressure Standby setting during startup to reduce the load on engine starters.

Solenoid Data – Normally Closed

Voltage	12V	24V
Maximum Current	1500 mA	665 mA
Inrush Current	1700 mA	800 mA
Coil Resistance @ 20°C [70°F]	7.1 Ω	28.5 Ω
PWM Range	200-300 Hz	
PWM Frequency (preferred)	250 Hz	
IP Rating (IEC 60529 DIN 40050-9)	IP67	IP67
IP Rating (IEC 60529 DIN 40050-9) with mating connector	IP69K	IP69K
Operating Temperature	Consistent with Pump Limits: -40°C (-40°F) to 104°C (220°F)	

The available Normally Closed Electric On/Off Controls for the Series 45 are shown below. The allowable Pressure Compensator (PC) and Load Sense (LS) pressure settings are provided for each frame in their respective sections.

General Information

Electric On/Off Controls Options – Normally Closed		Frame					
Code	Description	L	K	K2	J	F	E
AR	Electric On/Off Pressure Control w/Pressure Comp. (NC,12VDC) Left			•	•	•	•
CR	Electric On/Off Pressure Control w/Pressure Comp. (NC,24VDC) Left			•	•	•	•
AG	Electric On/Off Pressure Control w/Pressure Comp. (NC,12VDC) Right				•	•	•
AY	Electric On/Off Pressure Control w/Pressure Comp. (NC,24VDC) Right				•	•	•
BR	Electric On/Off Pressure Control w/Pressure Comp. (NC,12VDC) [>280 bar] Left				•	•	•
DR	Electric On/Off Pressure Control w/Pressure Comp. (NC,24VDC) [>280 bar] Left				•	•	•
BE	Electric On/Off Pressure Control w/Pressure Comp. (NC,12VDC) [>280 bar] Right				•	•	•
BG	Electric On/Off Pressure Control w/Pressure Comp. (NC,24VDC) [>280 bar] Right				•	•	•
EB	Electric On/Off Pressure Control w/Pressure Comp. (NC,12VDC)	•	•				
EE	Electric On/Off Pressure Control w/Pressure Comp. (NC,24VDC)	•	•				

Notes:

1. Left = E-Frame: CW Only, F-Frame: CW Only, J-frame: CW Axial, CCW Radial
2. Right = E-Frame: CCW Only, F-Frame: CCW Only, J-frame: CCW Axial, CW Radial
3. K/L Frame Controls are not rotation dependent
4. K2 Frame electric controls are limited only for Left orientation and up to 260 Bar

Electric On/Off Control Characteristic – Normally Open

The Normally Open configuration On/Off control directs the pump to its Low-Pressure Standby setting when no current is applied. When the required electric current (end current) is sent to the Normally Open configuration control, the pump pressure increases to the Pressure Compensation pressure setting. This control does not have Load Sense functionality, but rather acts as a Pressure Compensation control when energized, or is directed to its Low-Pressure Standby when de-energized. This control is especially useful for machine startups, as the pump can be directed to its Low Pressure Standby setting during startup to reduce the load on engine starters.

Solenoid Data – Normally Open

Voltage	12V	24V
Maximum Current	1500 mA	665 mA
Inrush Current	1700 mA	800 mA
Coil Resistance @ 20°C [70°F]	7.1 Ω	28.5 Ω
PWM Range	200-300 Hz	
PWM Frequency (preferred)	250 Hz	
IP Rating (IEC 60529 DIN 40050-9)	IP67	IP67
IP Rating (IEC 60529 DIN 40050-9) with mating connector	IP69K	IP69K
Operating Temperature	Consistent with Pump Limits: -40°C (-40°F) to 104°C (220°F)	

General Information

The available Normally Open Electric On/Off Controls for the Series 45 Frame E are shown below, with the allowable Pressure Compensator (PC) pressure range provided for each control. All Electric On/Off Controls are available with the 10-40bar Load Sense (LS) setting range.

Electric On/Off Controls Options – Normally Open		Frame					
Code	Description	L	K	K2	J	F	E
AN	Electric On/Off Pressure Control w/Pressure Comp. (NO,12VDC) Left			•	•	•	•
CN	Electric On/Off Pressure Control w/Pressure Comp. (NO,24VDC) Left			•	•	•	•
AF	Electric On/Off Pressure Control w/Pressure Comp. (NO,12VDC) Right				•	•	•
AT	Electric On/Off Pressure Control w/Pressure Comp. (NO,24VDC) Right				•	•	•
BN	Electric On/Off Pressure Control w/Pressure Comp. (NO,12VDC) [>280 bar] Left				•	•	•
DN	Electric On/Off Pressure Control w/Pressure Comp. (NO,24VDC) [>280 bar] Left				•	•	•
BF	Electric On/Off Pressure Control w/Pressure Comp. (NO,12VDC) [>280 bar] Right				•	•	•
DF	Electric On/Off Pressure Control w/Pressure Comp. (NO,24VDC) [>280 bar] Right				•	•	•
EA	Electric On/Off Pressure Control w/Pressure Comp. (NO,12VDC)	•	•				
EG	Electric On/Off Pressure Control w/Pressure Comp. (NO,24VDC)	•	•				

Notes:

1. Left = E-Frame: CW Only, F-Frame: CW Only, J-frame: CW Axial, CCW Radial
2. Right = E-Frame: CCW Only, F-Frame: CCW Only, J-frame: CCW Axial, CW Radial
3. K/L Frame Controls are not rotation dependent
4. K2 Frame electric controls are limited only for Left orientation and up to 260 Bar

Electric dump valve PC/LS controls

The electric dump valve pressure-compensated/load sense control allows the pump to operate as a PC/LS type control under normal operating conditions. The solenoid dump valve overrides the LS control, allowing the pump to operate in a Low-Pressure Standby mode. This function provides reduced horsepower and torque loss in certain situations. It may be particularly useful to reduce loads on a system during engine start.

When closed, the solenoid valve allows the control to act as a PC/LS control. When open, the solenoid valve allows flow from the incoming load sense pressure to dump to case. This reduces the pressure in the LS spring cavity, shifting the LS spool, and allows the pump to de-stroke to the Low-Pressure Standby condition. This control is for applications needing a PC/LS control with the ability to switch to Low-Pressure Standby electronically. The solenoid valve is only available in a normally closed configuration.

General Information

Electric Dump Control (frames E, F and J)

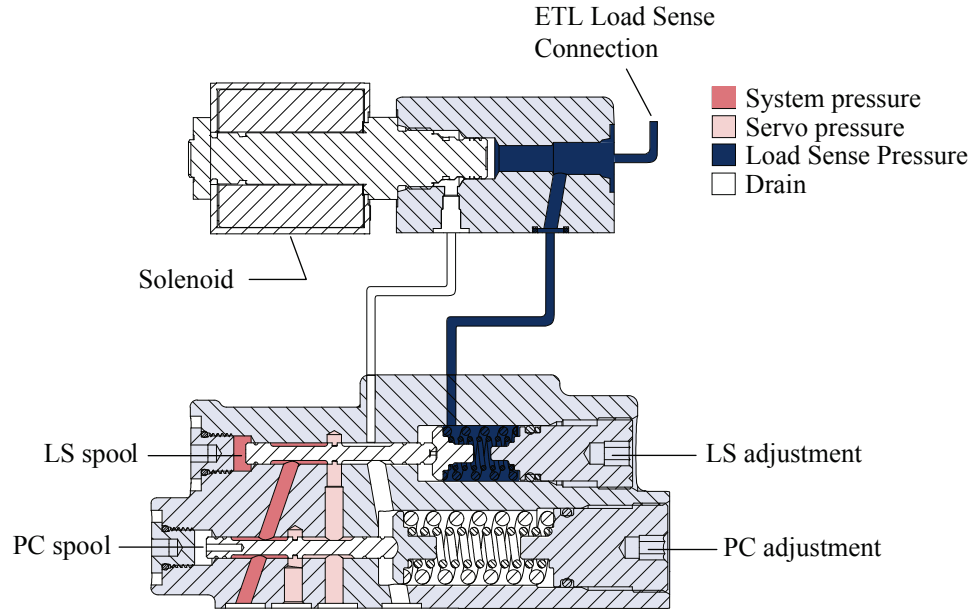

P108589

Electronic Torque Limiting Controls (ETL)

PLUS+1 Compliance

All controls for this product have met and passed the Danfoss PLUS+1[®] compliance standard testing, and as such, this product control is PLUS+1[®] Compliant. PLUS+1[®] compliance blocks (software) are available on the Danfoss website, |

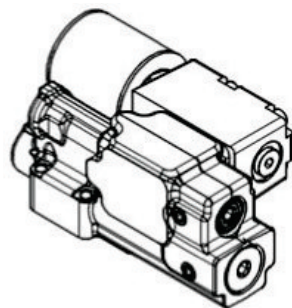

Electric Torque Limiting Control Principle

The Electronic Torque Limiting control consists of a normally closed proportional relief valve (PRV) integrated into a Pressure Compensated/Load Sensing control. This control operates as a PC/LS control, with the additional ability to limit load sense pressure using the integrated PRV by varying the current to the solenoid. When combined with an angle sensor, this control allows for a PC/LS control with electronic torque limiting.

General Information

J-frame pump with integrated ETL control

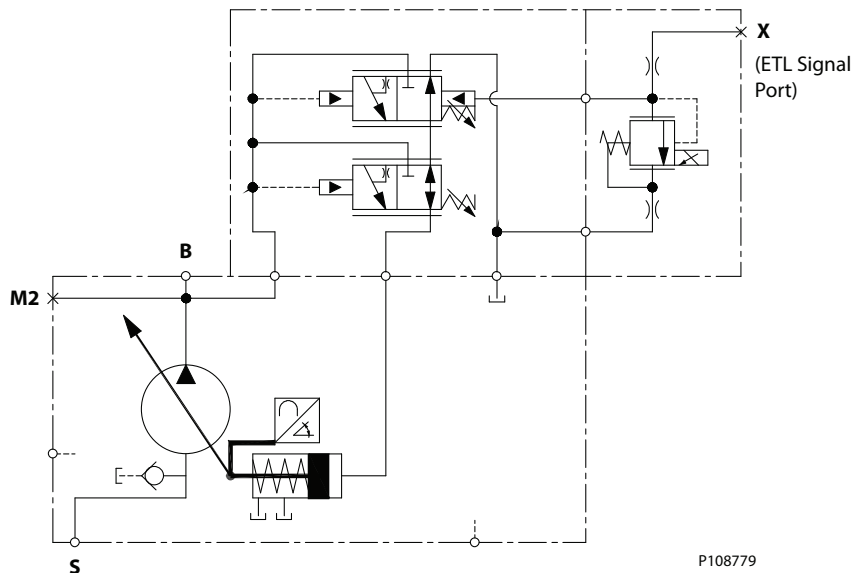

Pump torque consumption is a function of pump outlet pressure, pump displacement, and pump mechanical efficiency. When pump mechanical efficiency is considered constant, the pump torque can be limited when pump displacement is known and pump pressure is controlled. As pump displacement increases, the pump outlet pressure can be limited using the PRV to result in a constant torque limit. Pump outlet pressure is equal to the load sense pressure, which is limited with the PRV, plus the margin pressure setting of the pump.

$$Torque = \frac{Pump\ Outlet\ Pressure\ (bar) * Pump\ Displacement\ (\frac{cc}{rev})}{62.8 * Pump\ Mechanical\ Efficiency\ (\%)}$$

Electronic Torque Limiting Control Characteristic

The Electronic Torque Limiting control allows users to limit pump torque consumption electronically by combining a pressure limiting PRV and angle sensor. This torque limit can be changed with varying engine speeds (as shown in the Electronic Torque Limiting graph below), allowing the use of full engine torque at all engine speeds and increasing machine productivity. A microcontroller is required to store engine torque vs speed, receive the pump angle sensor signal, and then calculate and output the pump outlet pressure limit. The basic torque limiting control logic for a single engine speed is shown below. Danfoss offers a PLUS+1 subsystem application block for the Electronic Torque Limiting control option in combination with keyed MC-12 microcontroller hardware. Refer to graph [Operating Pressure vs. Input Current \(N.C. EPC\)](#) on page 19 for pressure vs. current information.

General Information

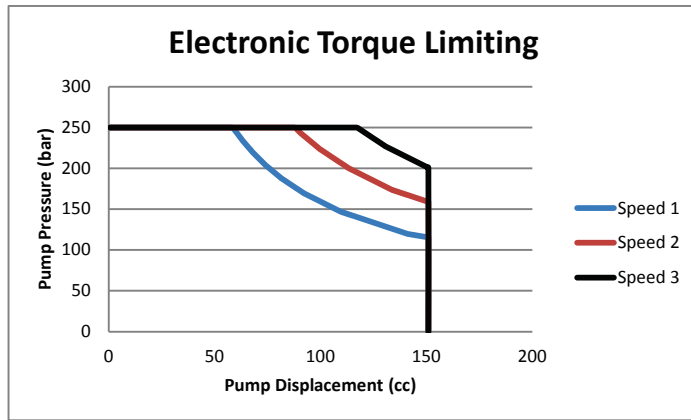

P108783

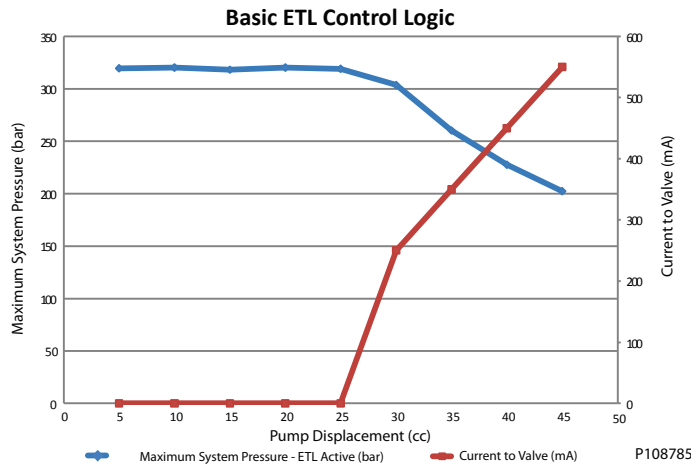

P108785

Fan Drive Control (FDC)

PLUS+1 Compliance

All Series 45 Electric controls have met and passed the Danfoss PLUS+1 compliance standard testing, and as such, this Series 45 control is PLUS+1 compliant. PLUS+1 compliance blocks (software) are available on the Danfoss website, within the PLUS+1 Guide section.

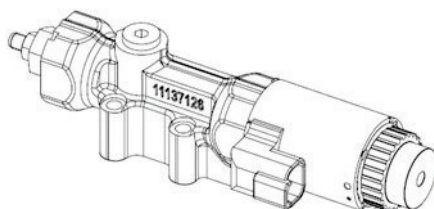

Fan Drive Control Principle

The Fan Drive Control is a unique electrically actuated pressure control solution that consists of a normally closed proportional solenoid and one dual diameter spool sliding in the control housing. System pressure acts on an area between the two spool diameters of the spool lands. This hydraulic force

General Information

is balanced with forces of springs and the solenoid when the spool is in the metering position. When no current is sent to the solenoid it operates the pump at or below the PC setting which is adjusted mechanically with the adjuster screw and lock nut. Increasing the control current proportionally reduces the pump's outlet pressure until a minimum standby pressure is reached.

Control Block 12V and 24V



The minimum system pressure is given by swashplate moments of the pump and by servo system leakages which produce a pressure drop across the control. In addition, fan motor type and fan inertia impact minimum system pressure.

The Normally Closed Fan Drive Control coupled with a microprocessor allows the pump to operate at an infinite range of operating pressures between a minimum system pressure and PC setting.

We recommend that a relief valve be installed in the pump outlet for additional system protection.

Warning

The Fan Drive Control is intended for fan drive systems only! Use in other systems could result in system component damage or unintended machine movement. The Fan Drive Control is not intended to serve at the primary system pressure relief. Loss of the input signal to this control will cause the pump to produce maximum flow.

Fan Drive Control System Characteristics

- Constant pressure and variable flow
- High or low system pressure mode based on fan cooling demand
- System flow adjusts to meet system requirements

Unintended Applications for Fan Drive Control Systems

- Applications with frequent PC events (system pressure overshoots)
- Adjustable Load Sensing systems

Fan Drive Control Cross Section

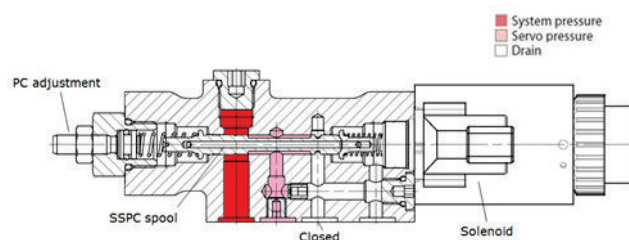

Fan Drive Control characteristic - Normally Closed

When an electric current is sent to the Normally Fan Drive Control, pump outlet pressure decreases proportionally to the increase in current. When the load in the system changes, the pump will adjust its

General Information

displacement to maintain the pressure demanded by the controlling current. This predictable control is especially useful for fan-drive systems, due to the direct relationship between fan-speed and pump pressure. Due to the nature of the Fan Drive Control, the relationship between current and pump pressure is unique for each individual PC pressure setting combination. The relationship between pump outlet pressure and control input current (for a 24V coil) is shown for various PC settings below. The hydraulic schematic for the Normally Closed Fan Drive Control is shown below as well.

Pump Outlet Pressure vs. control input current 24V Normally closed FDC (at 100Hz PWM)

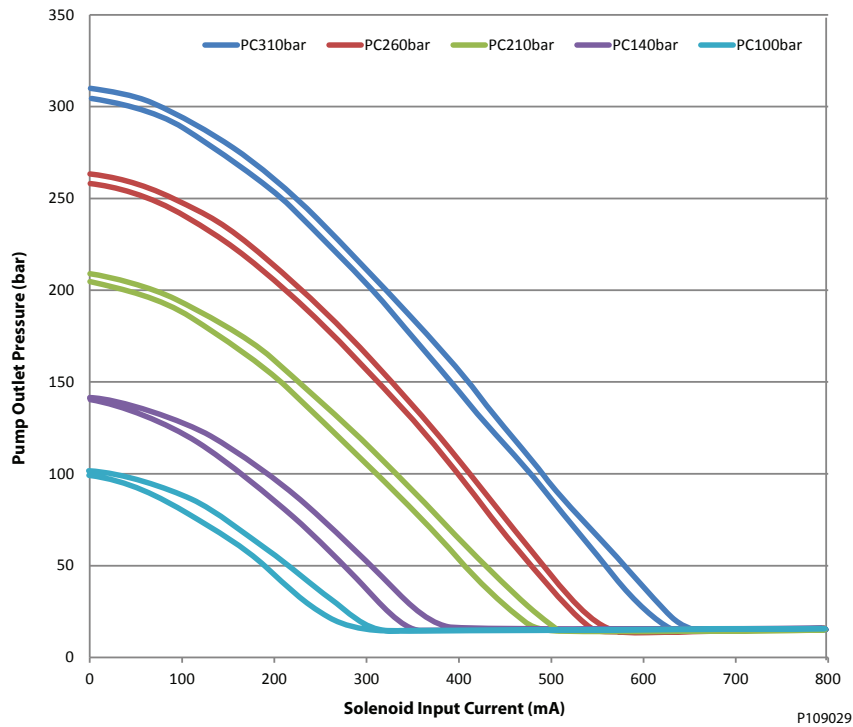

P109029

General Information

Pump Outlet Pressure vs. control input current 12V Normally closed FDC (at 100Hz PWM)

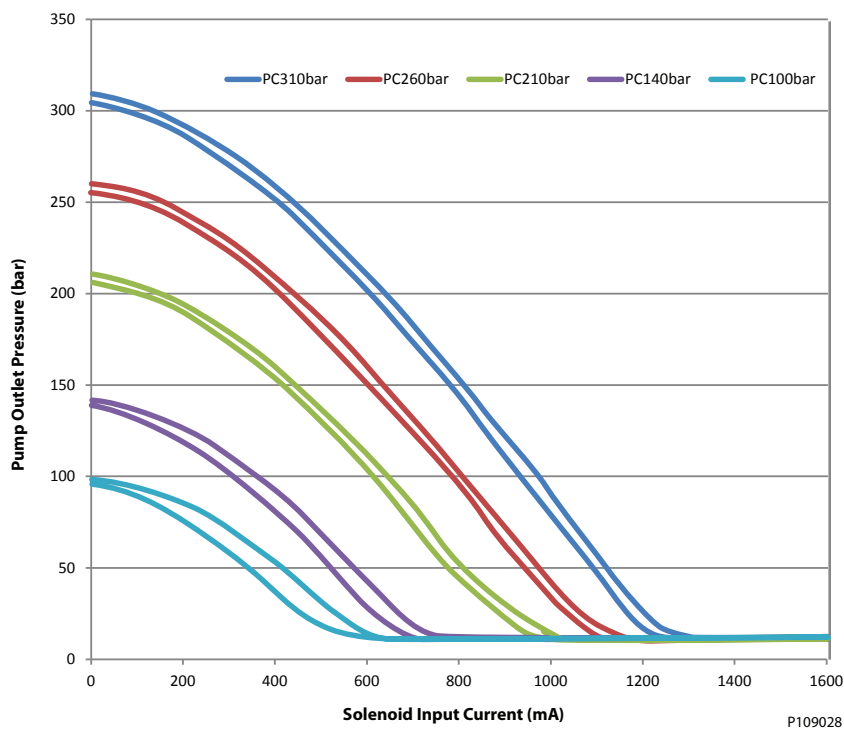

Attaining remarkably low system pressures is possible with the Fan Drive Control. The minimum system pressure is greatly dependent on individual system parameters such as fan motor type and fan size. This feature is highly desirable in low cooling demand conditions to keep fan speed as slow as possible.

Virtually eliminated control deadband increases controllability and reduces power loss. Control current resolution is greatly improved.

S45 pump with integrated FDC control Schematic

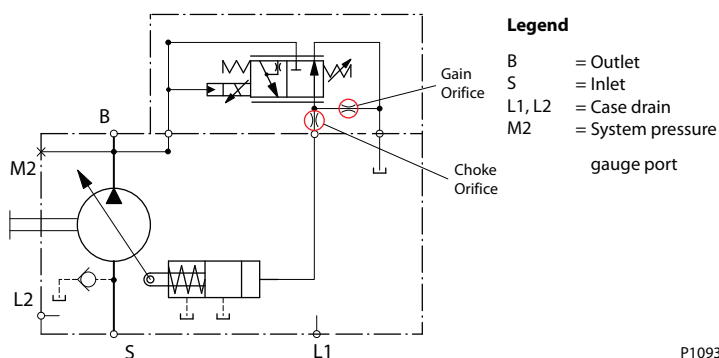

Solenoid data – Normally closed

Solenoid Data – Normally Closed

	12V	24V
Connector on solenoid	Deutsch DT04-2P	
Mating Connector (not included)	Deutsch DT06-2S	

General Information

Solenoid Data – Normally Closed (continued)

	12V	24V
Identification by color of nut	Black	Blue
Nominal current	1650 mA	840 mA
Maximum Control Current	1800 mA	920 mA
Environmental rating	IP67 without mating connector, IP69K with mating connector	
Maximum output driver current	2.0 Amps	
PLUS+1 dither frequency	Not recommended	
Useable PWM Frequency Range	50-200 Hz	
Recommended PWM Frequency	200 Hz	
Nominal Resistance at 20°C	3.66 Ω	14.2 Ω
Inductivity (pin at stroke end)	33 mH	140 mH
Minimum voltage	9.5 Vdc	19.0 Vdc
Maximum power	17.9 Watts	18.1 Watts

The Fan Drive Control is designed as a current driven control. It requires a PWM- input signal.

General Information

Fan Drive Control configuration

The available Normally Closed Fan Drive Controls for Series 45 are shown below. The allowable Pressure Compensator (PC) pressure settings are provided for each frame.

C module—Control

Fan Drive Control Options		Frame					
Code	Description	L	K	K2	J	F	E
SA	Fan Drive Control (12Vdc), 100-210 Bar, Left			•	•	•	
SB	Fan Drive Control (24Vdc), 100-210 Bar, Left			•	•	•	
SC	Fan Drive Control (12Vdc), 220-310 Bar, Left			•	•	•	
SD	Fan Drive Control (24Vdc), 220-310 Bar, Left			•	•	•	
SE	Fan Drive Control (12Vdc), 100-210 Bar, Right				•	•	
SF	Fan Drive Control (24Vdc), 100-210 Bar, Right				•	•	
SG	Fan Drive Control (12Vdc), 220-310 Bar, Right				•	•	
SH	Fan Drive Control (24Vdc), 220-310 Bar, Right				•	•	

G module options—Choke Orifice

Fan Drive Control options	Choke Orifice size
G	0.8 mm (0.031 in)
F	1.0 mm (0.039 in)

H module options—Gain Orifice

Fan Drive Control options	Gain Orifice Size
E	1.2 mm (0.047 in)

NC Fan Drive Control 3D Views

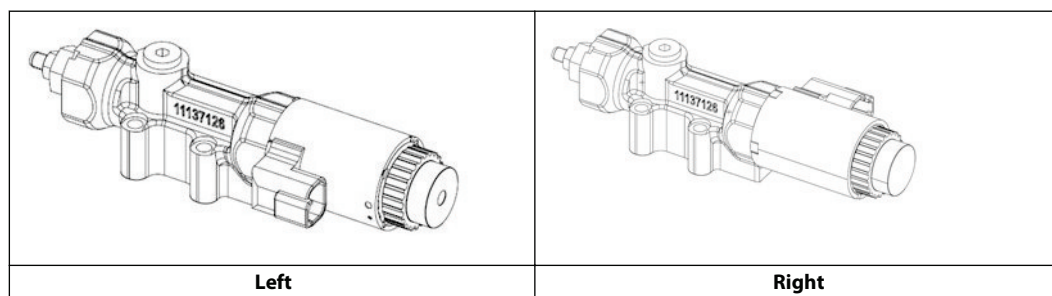

Angle Sensor

PLUS+1 Compliance

The Electric Angle Sensor has met and passed the Danfoss PLUS+1 compliance standard testing, and as such, this Angle Sensor is PLUS+1 compliant. PLUS+1 compliance blocks are available on the Danfoss website, within the PLUS+1 Guide section.



General Information

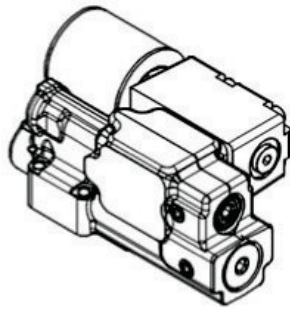

Angle Sensor Principle

The Series 45 Angle Sensor option allows users to measure the angle of pump displacement. The angle sensor is an electronic sensor mounted to the housing of the pump, which reads the pump stroke angle based on the swashplate position. Interfacing with the angle sensor is achieved through a 4-pin Deutsch DTM04-4P receptacle attached to a flexible connection cable (for a mating connector, use Deutsch® plug DTM06-4S). The sensor is mounted to the pump within an aluminum housing to prevent magnetic interference.

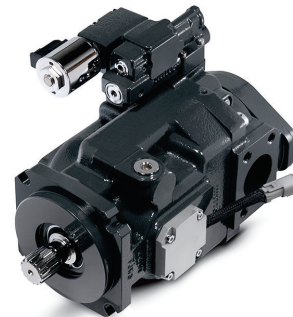
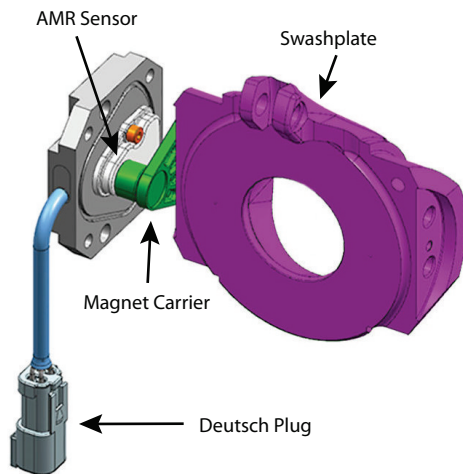

P108788

Angle Sensor Characteristics

The angle sensor package incorporates two sensor signals (primary & secondary), within a single sensor housing. This allows for improved accuracy and troubleshooting. For the 'Angle Sensor – Right' order code in the K module, the sensor is positioned according to the following conventions:

Code	Description	Frame				
		L	K	J	F	E
K Module - Housing						
A1R	SAE-C Flange 4-bolt, SAE O-ring boss ports, Single seal, Angle Sensor				•	
A2R	SAE-C Flange 4-bolt, SAE O-ring boss ports, Single seal, Angle Sensor			•		•
AFR	SAE-C Flange 2-bolt @45°, SAE O-ring boss ports, Single Seal, Angle Sensor			•		
M Module – Special Hardware						
ANS	Angle Sensor Hardware			•	•	•

General Information

J & F-Frame (45-90cc) Angle Sensor Identification Convention:

When looking at the input shaft with the control on the 'top' side, the angle sensor will be viewed on the right hand side. This convention is true for both Clockwise and Counter-clockwise rotation J & F-Frames.

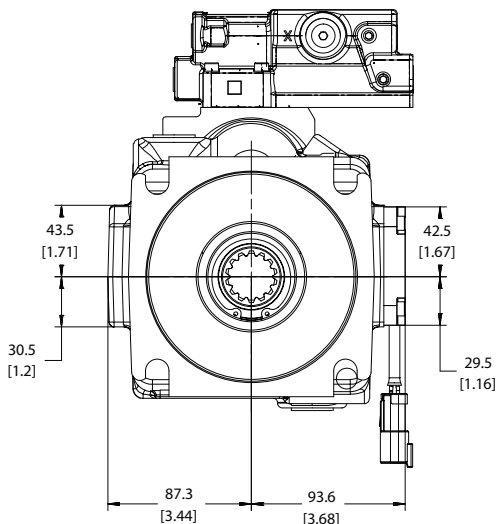

J Frame Angle Sensor Position

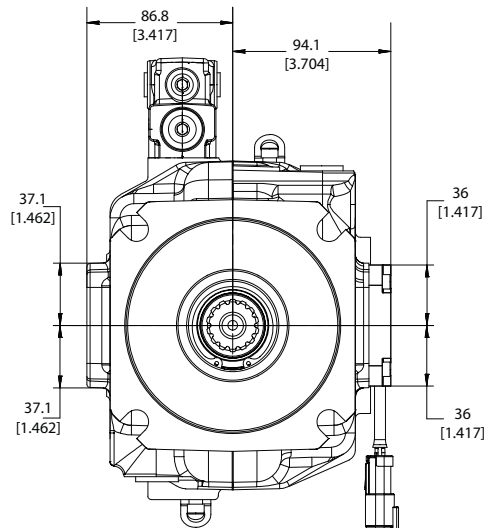

F Frame Angle Sensor Position

P108816

This sensor location yields a unique voltage versus swashplate angle characteristic curve which is the same for both Clockwise and Counter-clockwise rotation J & F-frames. Although each pair of curves will be unique for individual pumps, a general example of what to expect is provided below for J & F units with the 'Right' angle sensor position.

Sensor Output Voltage vs. Swashplate Angle

CW & CCW J & F-Frames (45-90cc)

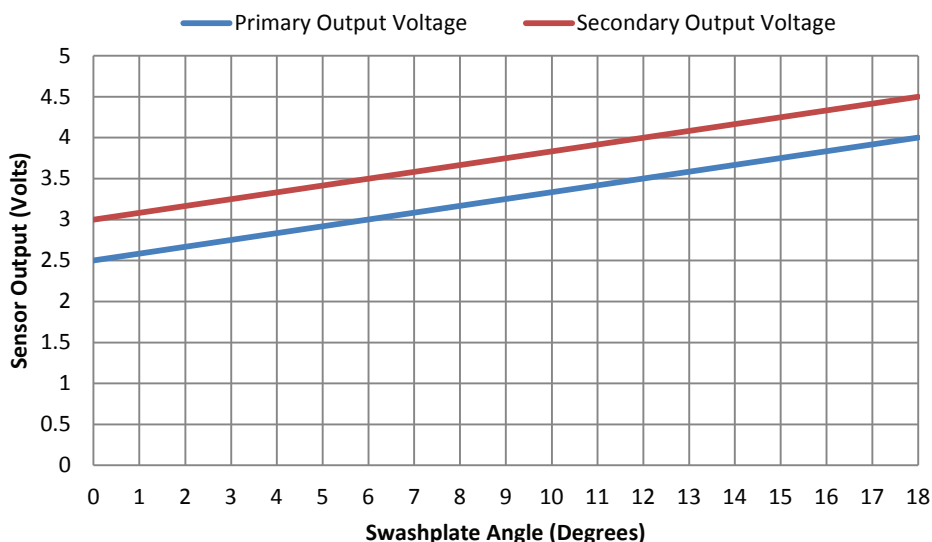

P108817

General Information

E-Frame (100-147cc) Angle Sensor Identification Convention:

The location convention for the E-Frame angle sensor is different from that of the J & F-Frame due to a difference in design of the endcap and servo systems. When looking at the input shaft, the angle sensor will be positioned on the same side as the outlet port of the endcap. The outlet port of the endcap is always the smaller of the inlet and outlet ports, indicated below. This is the 'right side' order code location, even though it appears on the left hand side from a frontal view.

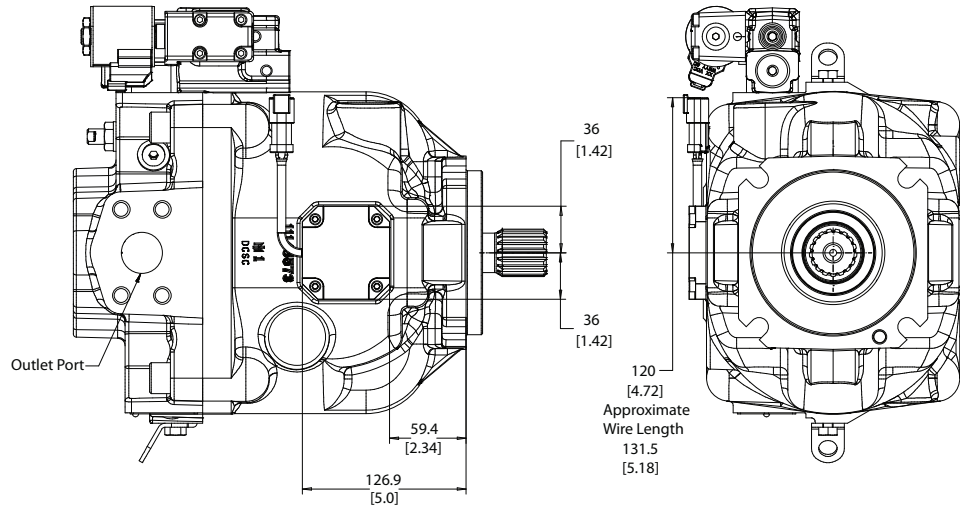

E Frame Angle Sensor Position

P108821

Clockwise rotation E-frames appear with the control on the top side in this view. Counter-clockwise rotation E-Frames appear with the control on the bottom side in this view.

This sensor location yields a unique voltage versus swashplate angle characteristic curve which is different for Clockwise and Counter-clockwise rotation E-frames. Although each pair of curves will be unique for individual pumps, a general example of what to expect is provided below for both Clockwise and Counter-clockwise rotation units with the **Right** angle sensor position.

General Information

Sensor Output Voltage vs. Swashplate Angle

CW E-Frames (100-147cc)

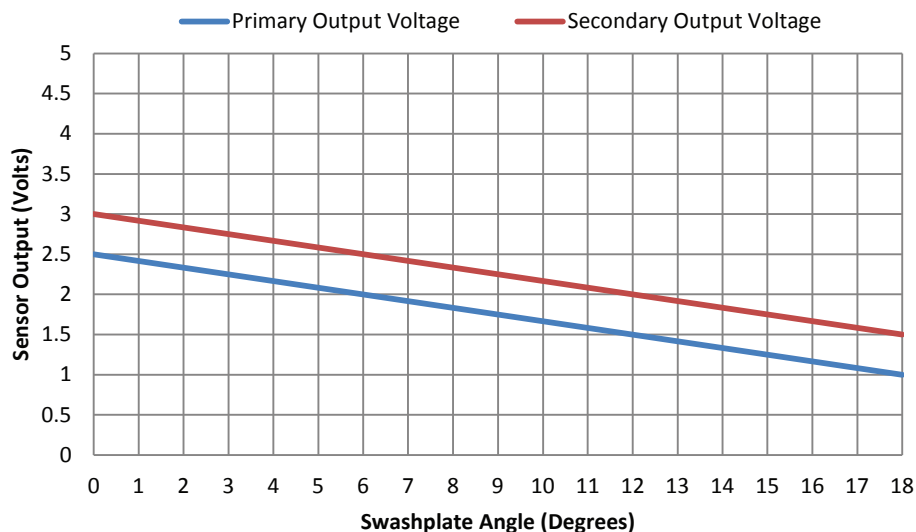

P108823

Sensor Output Voltage vs. Swashplate Angle

CCW E-Frames (100-147cc)

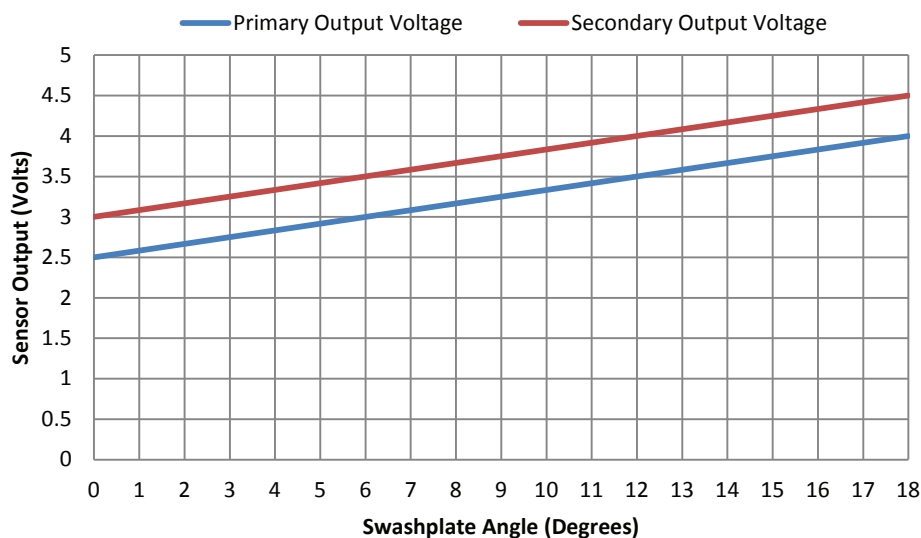

P108822

General Information

Angle sensor electrical specifications

Electrical specifications

Description	Minimum	Typical	Maximum	Unit	Note
Supply (V+)	4.75	5	5.25	Vdc	Sensor is ratiometric in the voltage range
Supply protection	—	—	28	Vdc	Sensor will switch off above 5.5 V
Supply current drawn	—	22	25	mA	Sensor supply at 5 V
Output short circuit current (VDD to SIG 1/2 and GND to SIG 1/2)	—	—	7.5	mA	Additional 7.5 mA for each sensor signal, total sensor 7.5x2+22=37 mA typical for FSO
Sensitivity in sensing range at calibration temperature for primary and secondary sensor	70.02	78	85.8	mV	—
Resolution	—	0.03	—	degree	11 bit output channel
Hysteresis	—	—	—	—	Design of sensor eliminates any mechanical hysteresis
Environment temperature range	-40 (-40)	80 (176)	104 (220)	°C (°F)	If temperature limits are exceeded, the sensor will function at a reduced level of performance
Operating temperature range	20 (68)	50 (122)	95 (203)	°C (°F)	Temperature of oil
Storage temperature	-40 (-40)	—	125 (257)	°C (°F)	—
Accuracy for primary and secondary signals throughout operating temperature range when calibrated at 50 deg. C	—	Primary: ±0.65 Secondary: ±0.85	—	degree	Includes linearity, temperature drift, and repeatability. Does not include the error due to offsets and different ferrous environment
Refresh rate of the sensor	—	—	100	µs	Internal ADC refresh rate

Angle Sensor Calibration

A 2-point calibration of the sensor is recommended, with points measured at pump standby, and maximum pump stroke. Maximum pump stroke can be achieved when the pump input shaft is not being turned, as Series 45 pumps are biased to maximum displacement. In some cases the pump may need to be turned momentarily to ensure the pump is in the maximum displacement position; this can be achieved through a momentary switching of the engine starter on/off.

Angle Sensor Functionality

The Series 45 angle sensor option is intended for functionality such as electronic torque limiting, duty cycle measurement, troubleshooting, etc. The angle sensor is PLUS+1 compliant with an available hardware compliance block.

Angle Sensor Intended Functionality:

- Electronic Torque Limiting
- Duty Cycle Recording
- Troubleshooting

Angle Sensor Unsupported Functionality:

- Displacement/Flow Control

Charge Pump Circuits

This section includes two general circuits for providing charge pressure to Series 45 pumps.

Example Circuit #1

Example Circuit #1 shows a generic open circuit charging layout.

General Information

In applications where the Series 45 pump does not have the required inlet pressure available, an external charge pump may be used to increase the inlet pressure to an acceptable level. Scenarios in which this may occur include a layout with the pump above the reservoir, high altitude conditions, etc.

For circuit type #1, follow these recommendations:

- Size the charge pump so that its flow is 10 to 20% greater than the Series 45 flow rate at worst case conditions
- Include a relief valve or check valve, as shown, between the charge pump and S45 pump with an initial pressure setting of up to 10 bar; if aeration at the inlet of the S45 pump is still present, increase the relief/cracking pressure up to 20 bar (maximum).

Generic open circuit

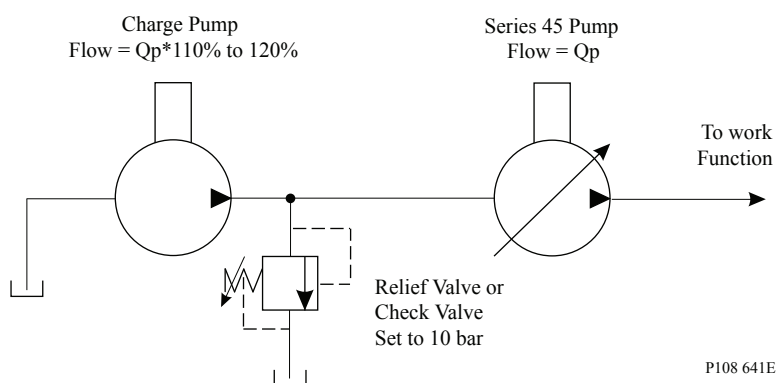

Example Circuit #2

Example Circuit #2 shows a semi-closed circuit charging layout.

In applications where the Series 45 pump does not have the required inlet pressure available, an external charge pump may be used to increase the inlet pressure to an acceptable level. Scenarios in which this may occur include a layout with the pump above the reservoir, high altitude conditions, etc.

For circuit type #2, follow these recommendations:

- Determine if the work function ever consumes more flow than it expels (for example: double acting or single acting cylinders). If so, determine the maximum flow differential in/out of the work function.
- Size the charge pump so that its flow is 10-20% of the Series 45 pump flow at worst case conditions, and increase this size by any work function flow differential which may occur.
- An inline oil cooler may be required for this type of circuit.
- Include an oil filter after the oil cooler; this ensures that any sediment in the oil cooler that may be dislodged due to vibration or any other reason is caught in the filter.
- Include a relief valve or check valve between the charge pump and S45 pump with an initial pressure setting of up to 10 bar; if aeration at the inlet of the S45 pump is still present, increase the relief/cracking pressure up to 20 bar (maximum).

General Information

Semi-closed circuit

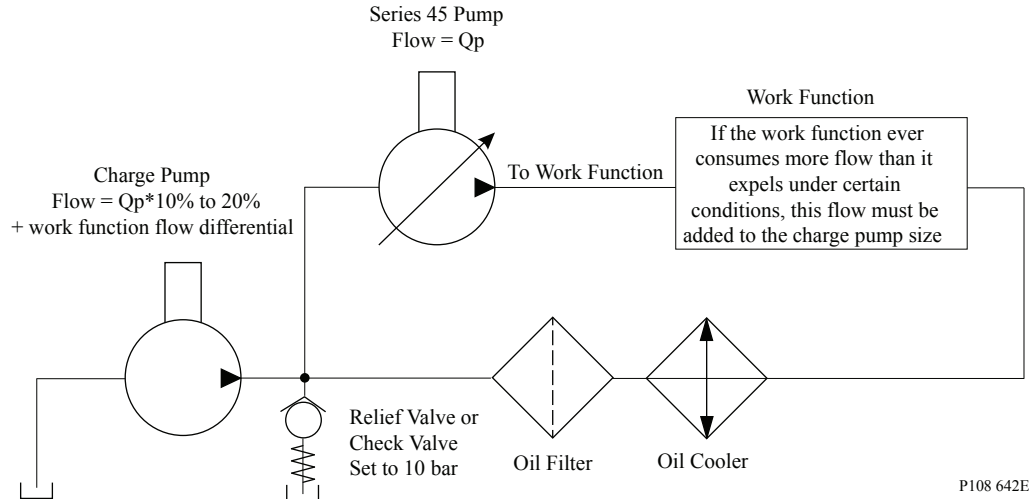

Operating parameters

Fluids

Ratings and performance data for Series 45 products are based on operating with premium hydraulic fluids containing oxidation, rust, and foam inhibitors. These include premium turbine oils, API CD engine oils per SAE J183, M2C33F or G automatic transmission fluids (ATF), Dexron II (ATF) meeting Allison C-3 or Caterpillar T0-2 requirements, and certain specialty agricultural tractor fluids. For more information on hydraulic fluid selection, see Danfoss publication **520L0463** Hydraulic Fluids and Lubricants, Technical Information, and **520L0465** Experience with Biodegradable Hydraulic Fluids, Technical Information.

Viscosity

Fluid viscosity limits

Condition		mm ² /s (cSt)	SUS
v min.	continuous	9	58
	intermittent	6.4	47
v max.	continuous	110	500
	intermittent (cold start)	1000	4700

Maintain fluid viscosity within the recommended range for maximum efficiency and pump life.

Minimum Viscosity – This should only occur during brief occasions of maximum ambient temperature and severe duty cycle operation.

Maximum Viscosity – This should only occur at cold start. Pump performance will be reduced. Limit speeds until the system warms up.

Temperature

Oil temperature limits are defined at the pump's case drain. As a rule of thumb, under steady state conditions the case drain temperature is approximately 20 - 25 degrees Centegrade higher than the pump's inlet oil temperature.

General Information

Frame L, K, J, F, & E Temperature Limits

Minimum (intermittent, cold start)	- 40° C [- 40° F]
Continuous	82° C [180° F]
Maximum Intermittent	104° C [220° F]

Frame L, K, J, F, & E Maximum Temperature limits are based on material properties. Don't exceed it. Measure temperature at the case drain of the pump.

K2 Frame Temperature Limits

Minimum (intermittent, cold start)	- 40° C [- 40° F]
Continuous	104° C [219° F]
Maximum Intermittent	115° C [239° F]

Frame K2 Maximum temperature limits are higher than other frame sizes & based on improved swashplate bearing material capabilities. Continuous operation at the Maximum Intermittent Temperature is possible with K2 if fluid viscosity requirements are maintained. *Minimum temperature* for all frame sizes relates to the physical properties of the component materials. Cold oil will not affect the durability of the pump components. However, it may affect the ability of the pump to provide flow and transmit power.

Ensure fluid temperature and viscosity limits are concurrently satisfied.

Inlet pressure

Inlet pressure limits

Minimum (continuous)	0.8 bar absolute [6.7 in. Hg vac.] (at reduced maximum speed)
Minimum (cold start)	0.5 bar absolute [15.1 in. Hg vac.]

Maintain inlet pressure within the limits shown in the table. Refer to Inlet pressure vs. speed charts for each displacement.

Case pressure

Case pressure limits

Maximum (continuous)	0.5 bar [7 psi] above inlet
Intermittent (cold start)	2 bar [29 psi] above inlet

Maintain case pressure within the limits shown in the table. The housing must always be filled with hydraulic fluid.

Caution

Operating outside of inlet and case pressure limits will damage the pump. To minimize this risk, use full size inlet and case drain plumbing, and limit line lengths.

General Information

Pressure ratings

The specification tables in each section give maximum pressure ratings for each displacement. Not all displacements within a given frame operate under the same pressure limits. Definitions of the operating pressure limits appear below.

Continuous working pressure is the average, regularly occurring operating pressure. Operating at or below this pressure should yield satisfactory product life. For all applications, the load should move below this pressure. This corresponds to the maximum allowable PC setting.

Maximum (peak) working pressure is the highest intermittent pressure allowed. Maximum machine load should never exceed this pressure, and pressure overshoots should not exceed this pressure. *See [Duty cycle and pump life](#).

Speed ratings

The specification tables in each section give minimum, maximum, and rated speeds for each displacement. Not all displacements within a given frame operate under the same speed limits. Definitions of these speed limits appear below.

Rated speed is the fastest recommended operating speed at full displacement and 1 bar abs. [0 in Hg vac] inlet pressure. Operating at or below this speed should yield satisfactory product life.

Maximum speed is the highest recommended operating speed at full power conditions. Operating at or beyond maximum speed requires positive inlet pressure and/or a reduction of pump outlet flow. Refer to Inlet pressure vs. speed charts for each displacement.

Minimum speed is the lowest operating speed allowed. Operating below this speed will not yield satisfactory performance.

Duty cycle and pump life

Knowing the operating conditions of your application is the best way to ensure proper pump selection. With accurate duty cycle information, your Danfoss representative can assist in calculating expected pump life.

Speed, flow, and inlet pressure

Inlet pressure vs. speed charts in each section show the relationship between speed, flow, and inlet pressure for each displacement. Use these charts to ensure your application operates within the prescribed range.

The charts define the area of inlet pressures and speeds allowed for a given displacement. Operating at lower displacements allows greater speed or lower inlet pressure.

Sample inlet pressure vs. speed chart

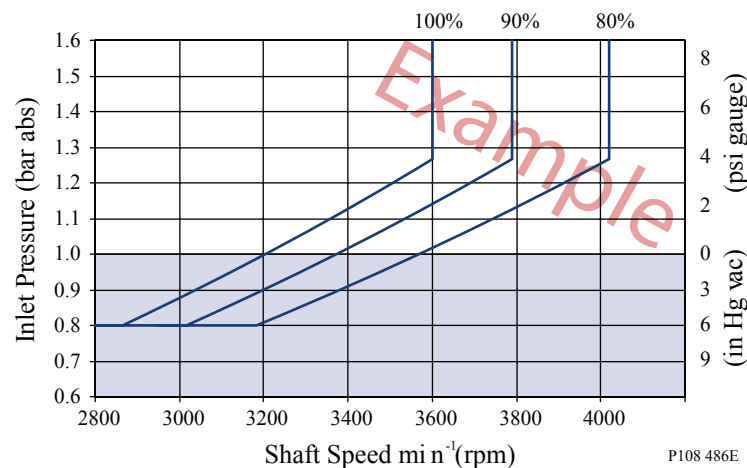

General Information

Operating limit at 80% displacement

Operating limit at 90% displacement

Operating limit at 100% displacement

Design parameters

Installation

Series 45 pumps may be installed in any position. To optimize inlet conditions, install the pump at an elevation below the minimum reservoir fluid level. Design inlet plumbing to maintain inlet pressure within prescribed limits (see [Inlet pressure](#) limits)

Fill the pump housing and inlet line with clean fluid during installation. Connect the case drain line to the uppermost drain port (L1 or L2) to keep the housing full during operation.

To allow unrestricted flow to the reservoir, use a dedicated drain line. Connect it below the minimum reservoir fluid level and as far away from the reservoir outlet as possible. Use plumbing adequate to maintain case pressure within prescribed limits (see [Case pressure](#) limits,).

Filtration

To prevent damage to the pump, including premature wear, fluid entering the pump inlet must be free of contaminants. Series 45 pumps require system filtration capable of maintaining fluid cleanliness at ISO 4406-1999 class 22/18/13 or better.

Danfoss does not recommend suction line filtration. Suction line filtration can cause high inlet vacuum, which limits pump operating speed. Instead we recommend a 125 μm (150 mesh) screen in the reservoir covering the pump inlet. This protects the pump from coarse particle ingestion.

Return line filtration is the preferred method for open circuit systems. Consider these factors when selecting a system filter:

- Cleanliness specifications
- Contaminant ingress rates
- Flow capacity
- Desired maintenance interval

Typically, a filter with a beta ratio of $\beta_{10} = 10$ is adequate. However, because each system is unique, only a thorough testing and evaluation program can fully validate the filtration system. For more information, see Danfoss publication **520L0467** Design Guidelines for Hydraulic Fluid Cleanliness.

Reservoir

The reservoir provides clean fluid, dissipates heat, and removes entrained air from the hydraulic fluid. It allows for fluid volume changes associated with fluid expansion and cylinder differential volumes. Minimum reservoir capacity depends on the volume needed to perform these functions. Typically, a capacity of one to three times the pump flow (per minute) is satisfactory.

Locate the reservoir outlet (suction line) near the bottom, allowing clearance for settling foreign particles. Place the reservoir inlet (return lines) below the lowest expected fluid level, as far away from the outlet as possible.

Fluid velocity

Choose piping sizes and configurations sufficient to maintain optimum fluid velocity, and minimize pressure drops. This reduces noise, pressure drops, and overheating. It maximizes system life and performance.

General Information

Recommended fluid velocities

System lines	6 to 9 m/sec [20 to 30 ft/sec]
Suction line	1 to 2 m/sec [4 to 6 ft/sec]
Case drain	3 to 5 m/sec [10 to 15 ft/sec]

Typical guidelines; obey all pressure ratings.

Velocity equations

SI units

Q = flow (l/min)

A = area (mm²)

Velocity = (16.67•Q)/A (m/sec)

US units

Q = flow (US gal/min)

A = area (in²)

Velocity = (0.321•Q)/A (ft/sec)

Shaft loads

Series 45 pumps have tapered roller bearings capable of accepting external radial and thrust (axial) loads. The external radial shaft load limits are a function of the load position, orientation, and the operating conditions of the pump.

The maximum allowable radial load (R_e) is based on the maximum external moment (M_e) and the distance (L) from the mounting flange to the load. Compute radial loads using the formula below. Tables in each section give maximum external moment (M_e) and thrust (axial) load (T_{in} , T_{out}) limits for each pump frame size and displacement.

Radial load formula

$$M_e = R_e \cdot L$$

L = Distance from mounting flange to point of load

M_e = Maximum external moment

R_e = Maximum radial side load

Shaft load orientation

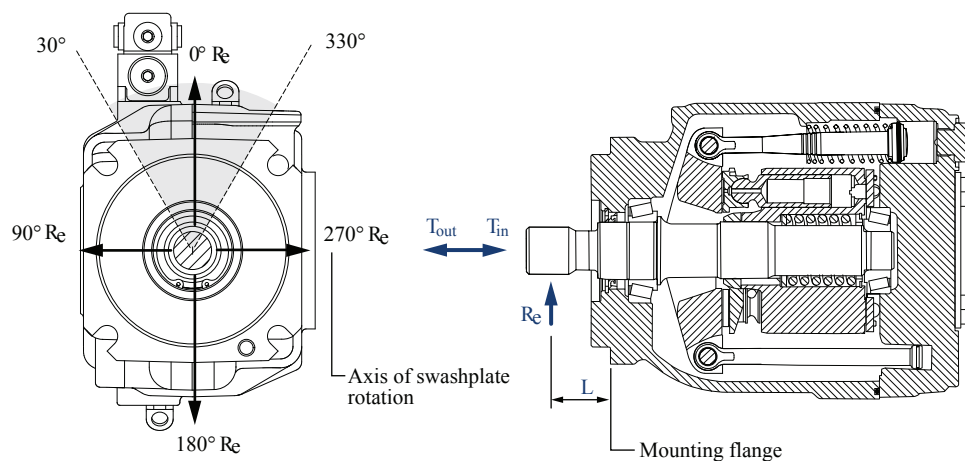

P101 080E

General Information

Bearing life

All shaft loads affect bearing life. In applications where external shaft loads can not be avoided, maximize bearing life by orientating the load between the 30° and 330° positions, as shown. Tapered input shafts or clamp-type couplings are recommended for applications with radial shaft loads.

Mounting flange loads

Adding auxiliary pumps and/or subjecting pumps to high shock loads may overload the pump mounting flange. Tables in each section give allowable continuous and shock load moments for each frame size. Applications with loads outside allowable limits require additional pump support.

- *Shock load moment* (M_s) is the result of an instantaneous jolt to the system.
- *Continuous load moments* (M_c) are generated by the typical vibratory movement of the application.

Estimating overhung load moments

Use the equations below to estimate the overhung load moments for multiple pump mounting. See installation drawings in each section to find the distance from the mounting flange to the center of gravity for each frame size. Refer to the technical specifications in each section to find pump weight.

Overhung load example

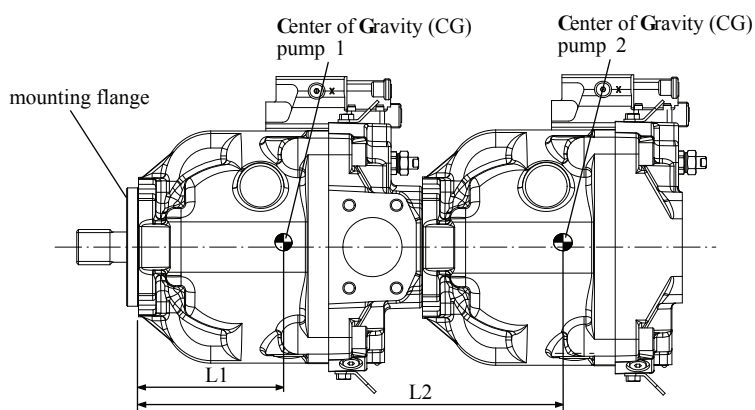

P101 081E

Shock load formula

$$M_s = G_s \cdot K \cdot (W_1 \cdot L_1 + W_2 \cdot L_2 + \dots + W_n \cdot L_n)$$

Continuous load formula

$$M_c = G_c \cdot K \cdot (W_1 \cdot L_1 + W_2 \cdot L_2 + \dots + W_n \cdot L_n)$$

SI units

M_s = Shock load moment (N·m)

M_c = Continuous (vibratory) load moment (N·m)

G_s = Acceleration due to external shock (G's)

G_c = Acceleration due to continuous vibration (G's)

K = Conversion factor = 0.00981

W_n = Mass of nth pump (kg)

L_n = Distance from mounting flange to nth pump CG (mm)

US units

M_s = Shock load moment (lbf·in)

M_c = Continuous (vibratory) load moment (lbf·in)

General Information

- G_s = Acceleration due to external shock (G's)
- G_c = Acceleration due to continuous vibration (G's)
- K = Conversion factor = 1
- W_n = Weight of nth pump (lb)
- L_n = Distance from mounting flange to nth pump CG (in)

Auxiliary mounting pads

Auxiliary mounting pads are available for all radial ported Series 45 pumps. Since the auxiliary pad operates under case pressure, use an O-ring to seal the auxiliary pump mounting flange to the pad. Oil from the main pump case lubricates the drive coupling.

- All mounting pads meet SAE J744 Specifications.
- The combination of auxiliary shaft torque and main pump torque must not exceed the maximum pump input shaft rating. Tables in each section give input shaft torque ratings for each frame size.
- Applications subject to severe vibratory or shock loading may require additional support to prevent mounting flange damage. Tables in each section give allowable continuous and shock load moments for each frame size.
- The drawing and table below give mating pump dimensions for each size mount. Refer to installation drawings in each section for auxiliary mounting pad dimensions.

Mating pump specifications

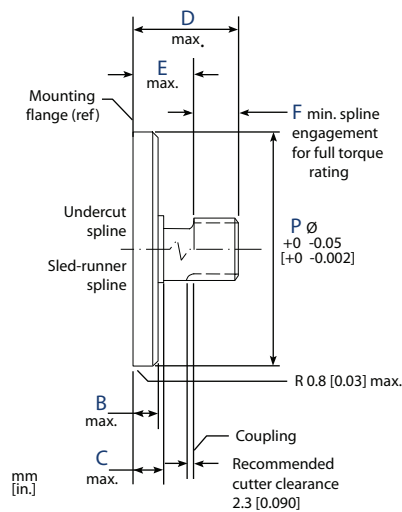

Dimensions

	SAE A	SAE B	SAE C
P	82.55 [3.250]	101.60 [4.000]	127.00 [5.000]
B	6.35 [0.250]	9.65 [0.380]	12.70 [0.500]
C	12.70 [0.500]	15.20 [0.600]	23.37 [0.920]
D	58.20 [2.290]	53.10 [2.090]	55.60 [2.190]

General Information

Dimensions (continued)

	SAE A	SAE B	SAE C
E	15.00 [0.590]	17.50 [0.690]	30.50 [1.200]
F	13.50 [0.530]	14.20 [0.560]	18.30 [0.720]

Input shaft torque ratings

Input shaft tables in each section give maximum torque ratings for available input shafts. Ensure that your application respects these limits.

Maximum torque ratings are based on shaft strength. Do not exceed them.

Coupling arrangements that are not oil-flooded provide a reduced torque rating. Contact your Danfoss representative for proper torque ratings if your application involves non oil-flooded couplings.

Danfoss recommends mating splines adhere to ANSI B92.1-Class 6e. Danfoss external splines are class 5 fillet root side fit. Tolerance classes 5 and 6e have the same minimum effective space width and maximum effective tooth thickness limits to ensure interchangeability between mating parts. Tables in each section give full spline dimensions and data.

Understanding and minimizing system noise

Charts in each section give sound levels for each frame size and displacement. Sound level data are collected at various operating speeds and pressures in a semi-anechoic chamber. Many factors contribute to the overall noise level of any application. Below is some information to help understand the nature of noise in fluid power systems, and some suggestions to help minimize it.

Noise is transmitted in fluid power systems in two ways: as fluid borne noise, and structure borne noise.

Fluid-borne noise (pressure ripple or pulsation) is created as pumping elements discharge oil into the pump outlet. It is affected by the compressibility of the oil, and the pump's ability to transition pumping elements from high to low pressure. Pulsations travel through the hydraulic lines at the speed of sound (about 1400 m/s [4600 ft/sec] in oil) until there is a change (such as an elbow) in the line. Thus, amplitude varies with overall line length and position.

Structure-borne noise is transmitted wherever the pump casing connects to the rest of the system. The way system components respond to excitation depends on their size, form, material, and mounting.

System lines and pump mounting can amplify pump noise. Follow these suggestions to help minimize noise in your application:

- Use flexible hoses.
- Limit system line length.
- If possible, optimize system line position to minimize noise.
- If you must use steel plumbing, clamp the lines.
- If you add additional support, use rubber mounts.
- Test for resonants in the operating range, if possible avoid them.

Understanding and minimizing system instability

Knowing the operating conditions and system setup of your application is the best way to ensure a stable system. All fan-drive circuits should use a choke orifice to ensure system stability. With accurate system information, your Danfoss representative can assist you in the selection of a servo control orifice.

Sizing equations

Use these equations to help select the right pump size, displacement and power requirements for your application:

General Information

	Based on SI units		Based on US units
<i>Flow</i>	Output flow Q = $\frac{V_g \cdot n \cdot \eta_v}{1000}$ (l/min)		Output flow Q = $\frac{V_g \cdot n \cdot \eta_v}{231}$ (US gal/min)
<i>Torque</i>	Input torque M = $\frac{V_g \cdot \Delta p}{20 \cdot \pi \cdot \eta_m}$ (N·m)		Input torque M = $\frac{V_g \cdot \Delta p}{2 \cdot \pi \cdot \eta_m}$ (lbf·in)
<i>Power</i>	Input power P = $\frac{M \cdot n \cdot \pi}{30\,000} = \frac{Q \cdot \Delta p}{600 \cdot \eta_t}$ (kW)		Input power P = $\frac{M \cdot n \cdot \pi}{198\,000} = \frac{Q \cdot \Delta p}{1714 \cdot \eta_t}$ (hp)

Variables

SI units [US units]

V_g = Displacement per revolution cm³/rev [in³/rev]

p_o = Outlet pressure bar [psi]

p_i = Inlet pressure bar [psi]

Δp = $p_o - p_i$ (system pressure) bar [psi]

n = Speed min⁻¹ (rpm)

η_v = Volumetric efficiency

η_m = Mechanical efficiency

η_t = Overall efficiency ($\eta_v \cdot \eta_m$)

Frame K2

Design

Series 45 Frame K2 pumps have a single servo piston design with a cradle-type swashplate set in polymer-coated journal bearings. A bias spring and internal forces increase swashplate angle. The servo piston decreases swashplate angle. Nine reciprocating pistons displace fluid from the pump inlet to the pump outlet as the cylinder block rotates on the pump input shaft. The block spring holds the piston slippers to the swashplate via the slipper retainer. The cylinder block rides on a bi-metal valve plate optimized for high volumetric efficiency and low noise. Tapered roller bearings support the input shaft and a viton lip-seal protects against shaft leaks.

An adjustable one spool (PC only, not shown) or two spool (LS and remote PC) control senses system pressure and load pressure (LS controls). The control ports system pressure to the servo piston, adjusting swashplate angle to control pump output flow.

Frame K2 cross section

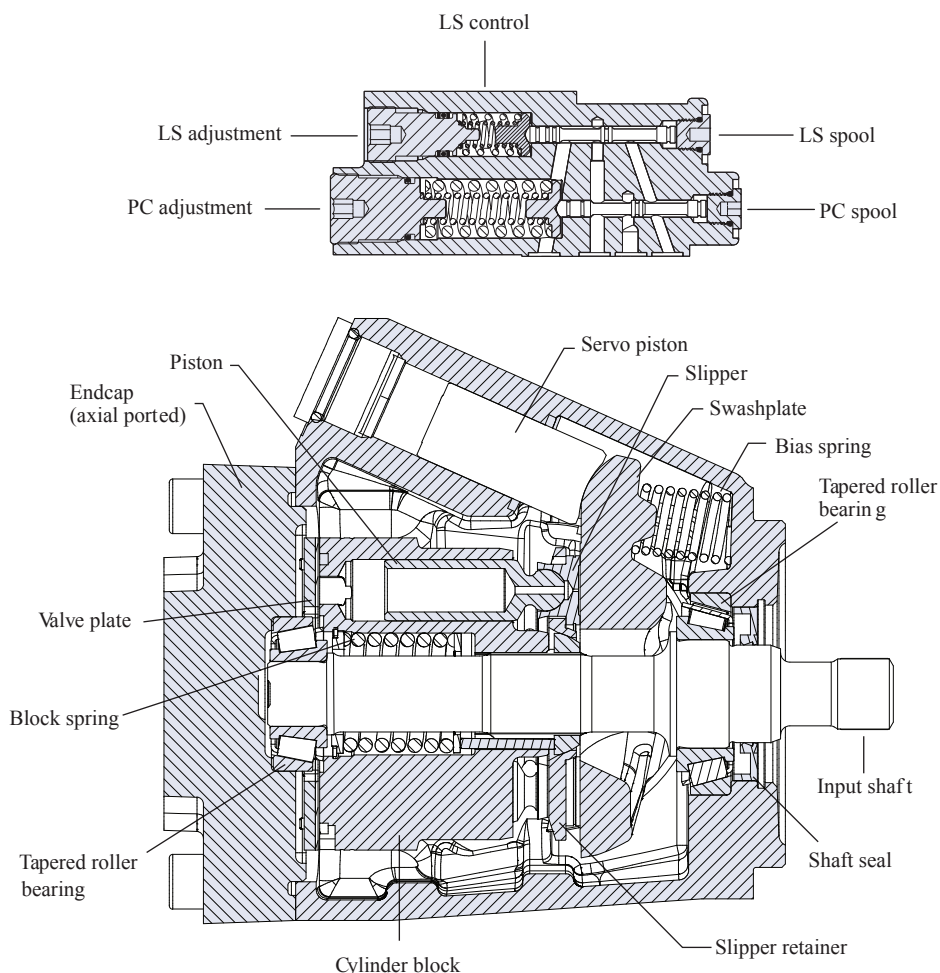

P109073

Frame K2

Technical Specifications

		K2 Frame				
		Unit	25C	30C	38C	45C
Maximum Displacement		cm ³ [in ³]	25 [1.53]	30 [1.83]	38 [2.32]	45 [2.75]
Working Input Speed	Minimum	min -1 (rpm)	500	500	500	500
	Continuous		3450	3200	2900	2900
	Maximum		3750	3450	3050	3050
Working Pressure	Continuous	bar [psi]	260 [3771]	260 [3771]	260 [3771]	260 [3771]
	Maximum		350 [5075]	350 [5075]	350 [5075]	350 [5075]
Flow at rated speed (theoretical)		l/min [US gal/min]	86.3 [22.8]	96.0 [25.4]	110.2 [29.1]	130.5 [34.5]
Input torque at maximum displacement (theoretical) at 49° C [120°F]		N·m/bar [lbf·in/1000 psi]	0.398 [243]	0.477 [291]	0.605 [369]	0.716 [438]
Mass moment of inertia of internal rotating components		kg·m ² [slug·ft ²]	0.00184 [0.00135]	0.00184 [0.00135]	0.00184 [0.00135]	0.00203 [0.00150]
Weight - Axial ports		kg [lb]	16 [35]			
Weight - Radial ports (no through drive)			17 [37]			
External Shaft Loads	External moment (Me)	N·m [lbf·in]	61 [540]	61 [540]	76 [673]	76 [673]
	Thrust in (Tin), out (Tout)	N [lbf]	1000 [225]	1000 [225]	1200 [270]	1200 [270]
Mounting flange load moments	Vibratory (continuous)	N·m [lbf·in]	1005 [8895]			
	Shock (maximum)		3550 [31420]			

Order Code

Code description

Code	Description
R	Product Frame, Variable Open Circuit Pump
S	Rotation
P	Displacement
C	Control Type
D	Pressure Compensator Setting
E	Load Sense Setting
F	Not Used
G	Choke Orifice
H	Gain Orifice
J	Input Shaft/Auxiliary Mount/Endcap
K	Shaft Seal/Front Mounting Flange/Housing Ports
L	Displacement Limiter

Frame K2

Code description (continued)

Code	Description
M	Special Hardware
N	Special Features

R Frame

		K2 Frame			
		025C	030C	038C	045C
K2	K2 Frame, variable displacement open circuit pump	•	•	•	•

S Rotation

		K2 Frame			
		025C	030C	038C	045C
L	Left Hand (counterclockwise)	•	•	•	•
R	Right Hand (clockwise)	•	•	•	•

P Displacement

025C	025 cm ³ /rev [1.53 in ³ /rev]	•			
030C	030 cm ³ /rev [1.83 in ³ /rev]		•		
038C	038 cm ³ /rev [2.32 in ³ /rev]			•	
045C	045 cm ³ /rev [2.75 in ³ /rev]				•

C Control type

		K2 Frame			
		025C	030C	038C	045C
PC	Pressure Compensator	•	•	•	•
RP	Remote Pressure Compensator	•	•	•	•
LB	Load Sensing/Pressure Comp. w/Bleed Orifice	•	•	•	•
LJ	Load Sensing/Pressure Comp. (Metric)	•	•	•	•
LS	Load Sensing/Pressure Comp.	•	•	•	•
FB	Electric Dump valve (On/Off) w/Load sensing / Pressure comp. (NC, 12VDC), Left	•	•	•	•
FE	Electric Dump valve (On/Off) w/Load sensing / Pressure comp. (NC, 24VDC), Left	•	•	•	•
FL	Load Sensing/Pressure Comp. (Metric) (NC,24VDC)	•	•	•	•
FJ	Load Sensing/Pressure Comp. (NO,12VDC), Left	•	•	•	•
FM	Load Sensing/Pressure Comp. (NO,24VDC), Left	•	•	•	•
AH	Electric Proportional Pressure Control w/Pressure comp. (NC,12VDC), Left	•	•	•	•
AL	Electric Proportional Pressure Control w/Pressure comp. (NC,24VDC), Left	•	•	•	•
AX	Electric Proportional Pressure Control w/Pressure comp. (NO,12VDC), Left	•	•	•	•
CL	Electric Proportional Pressure Control w/Pressure comp. (NO,24VDC), Left	•	•	•	•
AR	Electric On/Off Pressure Control w/Pressure comp. (NC,12VDC), Left	•	•	•	•
CR	Electric On/Off Pressure Control w/Pressure comp. (NC,24VDC), Left	•	•	•	•
AN	Electric On/Off Pressure Control w/Pressure comp. (NO,12VDC), Left	•	•	•	•

Frame K2

C Control type (continued)

CN	Electric On/Off Pressure Control w/Pressure comp. (NO,24VDC), Left	•	•	•	•
SA	Fan drive control (12Vdc),100-210 Bar, Left	•	•	•	•
SB	Fan drive control (24Vdc),100-210 Bar, Left	•	•	•	•
SC	Fan drive control (12Vdc),220-260 Bar, Left	•	•	•	•
SD	Fan drive control (24Vdc),220-260 Bar, Left	•	•	•	•

D PC setting (2 digit code, 10 bar increments)

Example	25 = 250 bar (3625 psi)				
10-26	100 to 260 bar [1450 to 3771 psi]	•	•	•	•

E Load sensing setting (2 digit code, 1 bar increments)

Example	20 = 20 bar (290 psi)				
10-40	10 to 40 bar [145 to 580 psi]	•	•	•	•
NN	Not applicable (pressure compensated only controls)	•	•	•	•

F Not used

NN	Not applicable	•	•	•	•
----	----------------	---	---	---	---

G Servo Control Orifice

N	None (standard)	•	•	•	•
E	0.8 mm diameter - Electrical proportional controls only	•	•	•	•
F	1.0 mm diameter - Electrical proportional controls only	•	•	•	•
R	0.8 mm diameter - FDC only	•	•	•	•
S	1.0 mm diameter - FDC only	•	•	•	•

H Gain Orifice

3	0.7 mm diameter	•	•	•	•
E	Gain orifice FDC only, 1.2mm dia	•	•	•	•

J Input Shaft

C2	13 tooth, 16/32 pitch
C3	15 tooth, 16/32 pitch
K1	0.875 inch straight keyed
K2	0.875 inch straight keyed (long)

Auxiliary Mount/Endcap Style

Code	Auxiliary Description	Endcap Style	Inlet Porting	Outlet Porting	Endcap Description
MF	None	Axial	O-Ring Boss	O-Ring Boss	Inlet - SAE O-Ring boss port (1.875 inch threads) Outlet - SAE O-Ring boss port (1.3125 inch threads)
MP	None	Axial	Split Flange	Split Flange	Inlet - Code 61 Split Flange Port 4 Bolt (1.25 inch port M10 threads) Outlet - Code 61 Split Flange Port 4 Bolt (1 inch port M10 threads)

Frame K2

Auxiliary Mount/Endcap Style (continued)

NA	None	Axial	O-Ring Boss	O-Ring Boss	Inlet - ISO O-Ring boss port (M42 threads) Outlet - ISO O-Ring boss port (M33 threads)
MG	None	Radial	O-Ring Boss	O-Ring Boss	Inlet - SAE O-Ring boss port (1.875 inch threads) Outlet - SAE O-Ring boss port (1.3125 inch threads)
NS	None	Radial	O-Ring Boss	O-Ring Boss	Inlet - ISO O-Ring boss port (M48 threads) Outlet - ISO O-Ring boss port (M33 threads)
MR	None	Radial	Split Flange	Split Flange	Inlet - Code 61 Split Flange Port 4 Bolt (1.5 inch port 0.5 inch threads) Outlet - Code 61 Split Flange Port 4 Bolt (1 inch port 0.375 inch threads)
RG	Running Cover	Radial	O-Ring Boss	O-Ring Boss	Inlet - SAE O-Ring boss port (1.875 inch threads) Outlet - SAE O-Ring boss port (1.3125 inch threads)
RR	Running Cover	Radial	Split Flange	Split Flange	Inlet - Code 61 Split Flange Port 4 Bolt (1.5 inch port M12 threads) Outlet - Code 61 Split Flange Port 4 Bolt (1 inch port M10 threads)
AB	SAE-A 9 teeth, M10 threads	Radial	O-Ring Boss	O-Ring Boss	Inlet - ISO O-Ring boss port (M48 threads) Outlet - ISO O-Ring boss port (M33 threads)
AG	SAE-A, 9 teeth, M10 threads	Radial	O-Ring Boss	O-Ring Boss	Inlet - SAE O-Ring boss port (1.875 inch threads) Outlet - SAE O-Ring boss port (1.3125 inch threads)
AK	Integrated SAE-A, 9 teeth, M10 threads	Radial	Split Flange	Split Flange	Inlet - Code 61 Split Flange Port 4 Bolt (1.5 inch port M12 threads) Outlet - Code 61 Split Flange Port 4 Bolt (1 inch port M10 threads)
FB	Integrated SAE-A, 9 teeth, M10 threads	Radial	O-Ring Boss	O-Ring Boss	Inlet - ISO O-Ring boss port (M48 threads) Outlet - ISO O-Ring boss port (M33 threads)
FG	Integrated SAE-A, 9 teeth, M10 threads	Radial	O-Ring Boss	O-Ring Boss	Inlet - SAE O-Ring boss port (1.875 inch threads) Outlet - SAE O-Ring boss port (1.3125 inch threads)
EK	SAE-A, 9 teeth, M10 threads	Radial	Split Flange	Split Flange	Inlet - Code 61 Split Flange Port 4 Bolt (1.5 inch port 0.5 inch threads) Outlet - Code 61 Split Flange Port 4 Bolt (1 inch port 0.375 inch threads)
TK	SAE-A, 11 teeth, M10 threads	Radial	Split Flange	Split Flange	Inlet - Code 61 Split Flange Port 4 Bolt (1.5 inch port 0.5 inch threads) Outlet - Code 61 Split Flange Port 4 Bolt (1 inch port 0.375 inch threads)
GG	SAE-A, 11 teeth, M10 threads	Radial	O-Ring Boss	O-Ring Boss	Inlet - SAE O-Ring boss port (1.875 inch threads) Outlet - SAE O-Ring boss port (1.3125 inch threads)
GT	SAE-A, 11 teeth, M10 threads	Radial	O-Ring Boss	O-Ring Boss	Inlet - ISO O-Ring boss port (M48 threads) Outlet - ISO O-Ring boss port (M33 threads)
BG	SAE-B, 13 teeth, M12 threads	Radial	O-Ring Boss	O-Ring Boss	Inlet - SAE O-Ring boss port (1.875 inch threads) Outlet - SAE O-Ring boss port (1.3125 inch threads)
BB	SAE-B, 13 teeth, M12 threads	Radial	O-Ring Boss	O-Ring Boss	Inlet - ISO O-Ring boss port (M48 threads) Outlet - ISO O-Ring boss port (M33 threads)

Frame K2

Auxiliary Mount/Endcap Style (continued)

DR	SAE-B, 13 teeth, M12 threads	Radial	Split Flange	Split Flange	Inlet - Code 61 Split Flange Port 4 Bolt (1.5 inch port M12 threads) Outlet - Code 61 Split Flange Port 4 Bolt (1 inch port M10 threads)
VG	SAE-BB, 15 teeth, M12 threads	Radial	O-Ring Boss	O-Ring Boss	Inlet - SAE O-Ring boss port (1.875 inch threads) Outlet - SAE O-Ring boss port (1.3125 inch threads)
VK	SAE-BB, 15 teeth, M12 threads	Radial	Split Flange	Split Flange	Inlet - Code 61 Split Flange Port 4 Bolt (1.5 inch port 0.5 inch threads) Outlet - Code 61 Split Flange Port 4 Bolt (1 inch port 0.375 inch threads)

J Input Shaft/Auxiliary Mount/Endcap

Available Combinations

	K2 Frame			
	025C	030C	038C	045C
C2MF	•	•	•	•
C2MG	•	•	•	•
C2MP	•	•	•	•
C2MR	•	•	•	•
C2TK	•	•	•	•
C3AB	•	•	•	•
C3DR	•	•	•	•
C3MF	•	•	•	•
C3MG	•	•	•	•
C3MP	•	•	•	•
C3MR	•	•	•	•
K1RG	•	•	•	•
C2NA	•	•	•	•
C3NA	•	•	•	•
C2NS	•	•	•	•
C3NS	•	•	•	•
C2RR	•	•	•	•
C3RR	•	•	•	•
C2EK	•	•	•	•
C3EK	•	•	•	•
C3TK	•	•	•	•
C2DR	•	•	•	•
C2VK	•	•	•	•
C3VK	•	•	•	•
C2AK	•	•	•	•
C3AK	•	•	•	•
C3FG	•	•	•	•
C2AB	•	•	•	•
C2BB	•	•	•	•

Frame K2

	K2 Frame			
	025C	030C	038C	045C
C3BB	•	•	•	•
C2GT	•	•	•	•
C3GT	•	•	•	•
C2RG	•	•	•	•
C3RG	•	•	•	•
C2AG	•	•	•	•
C3AG	•	•	•	•
C2GG	•	•	•	•
C3GG	•	•	•	•
C2BG	•	•	•	•
C3BG	•	•	•	•
C2VG	•	•	•	•
C3VG	•	•	•	•
C3FB	•	•	•	•
C2FB	•	•	•	•
C2FG	•	•	•	•
K1MF	•	•	•	•
K2MF	•	•	•	•
K2RG	•	•	•	•

K Shaft seal

		K2 Frame			
		025C	030C	038C	045C
A	Single (Viton [FKM])	•	•	•	•

K Mounting flange and housing port style

6	SAE-B Flange 2-bolt/SAE O-ring boss ports [7/8-14]	•	•	•	•
---	--	---	---	---	---

K Not used

N	Not applicable	•	•	•	•
---	----------------	---	---	---	---

L Displacement limiter

PLB	None (plugged)	•	•	•	•
AAA	Adjustable, factory set at max angle	•	•	•	•

M Special hardware

NNN	None	•	•	•	•
-----	------	---	---	---	---

N Special features

NNN	None	•	•	•	•
-----	------	---	---	---	---

Frame K2

Performance K2-25C

Flow and power data valid at 49°C [120°F] and viscosity of 17.8 mm²/sec [88 SUS].

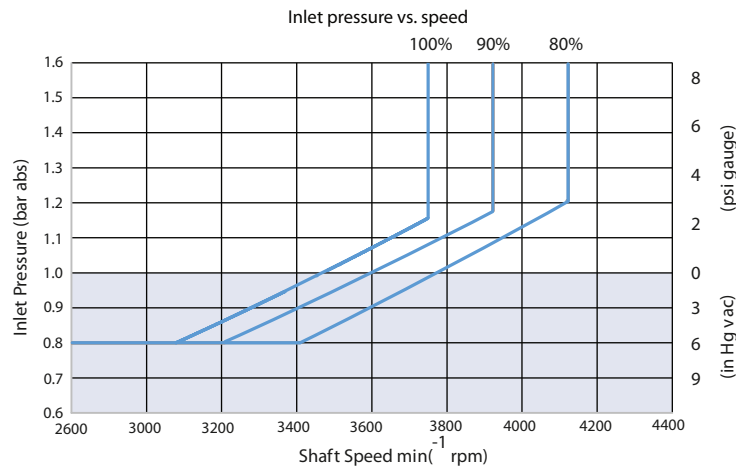
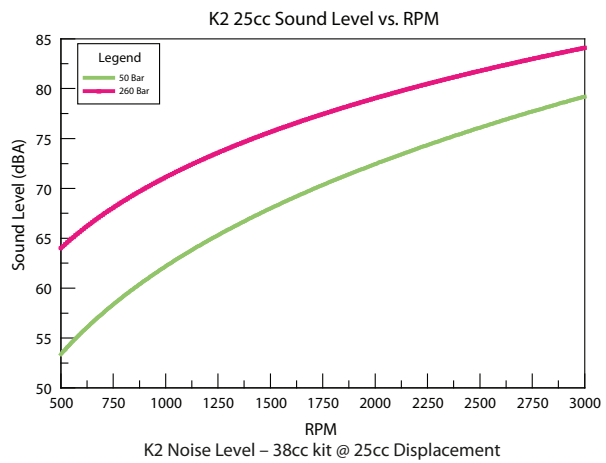
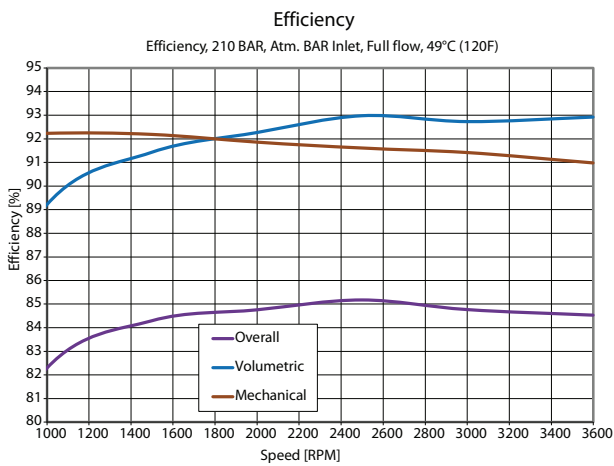
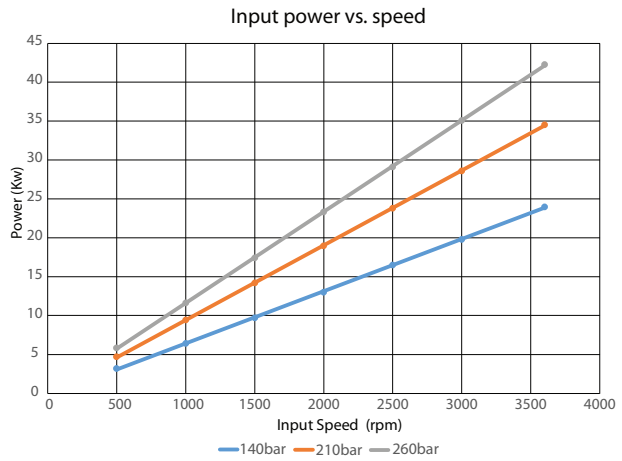
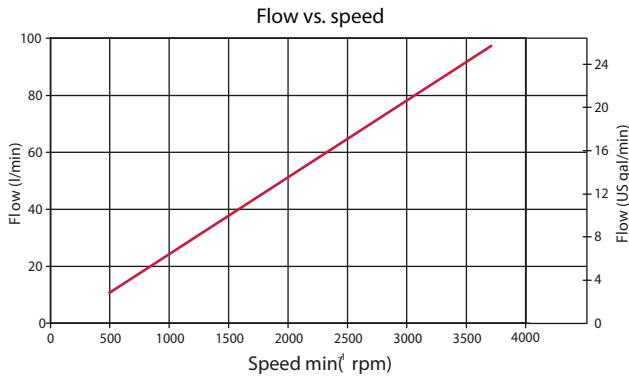

P109103

Frame K2

Performance K2-30C

Flow and power data valid at 49°C [120°F] and viscosity of 17.8 mm²/sec [88 SUS].

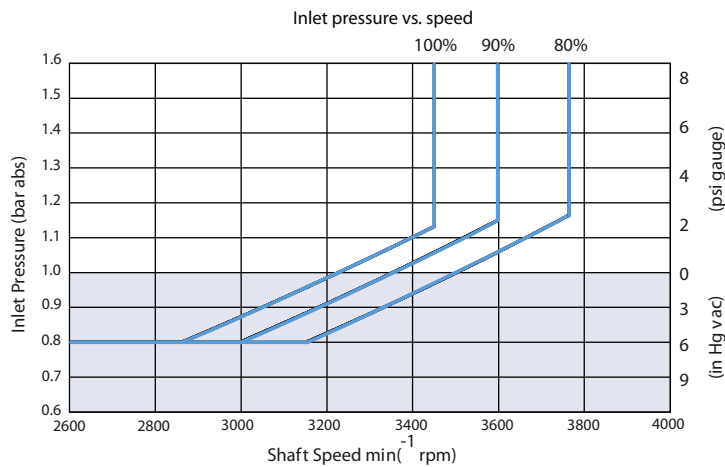
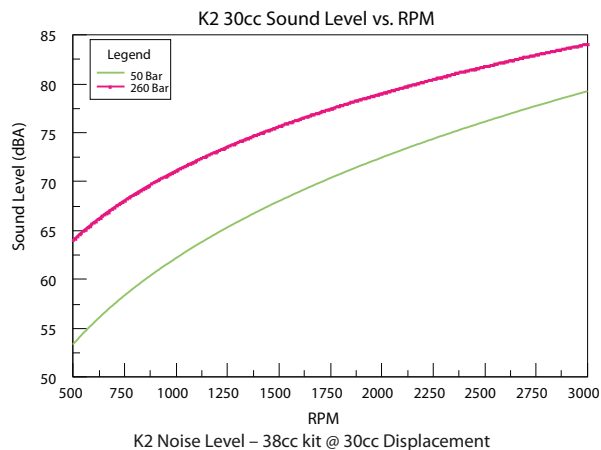
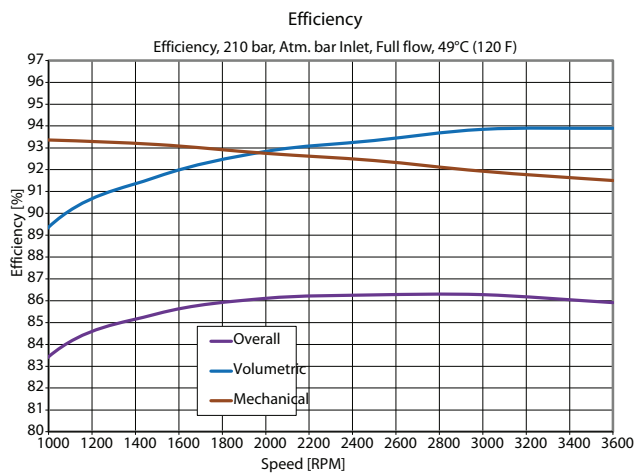
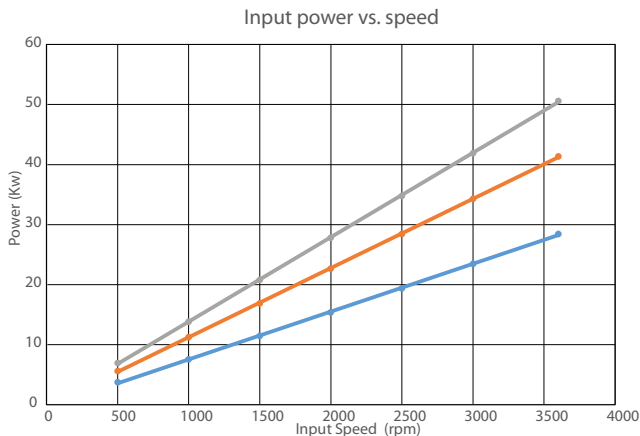
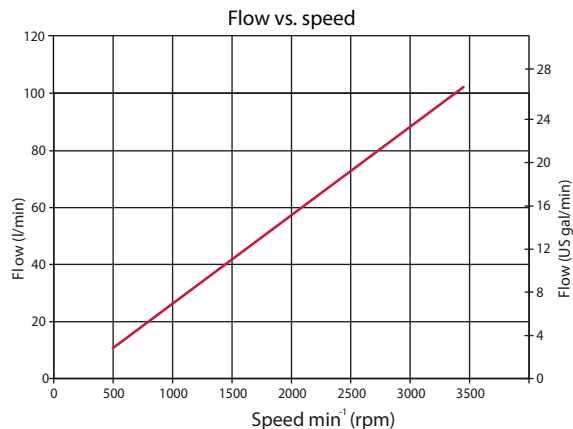

P109104

Frame K2

Performance K2-38C

Flow and power data valid at 49°C [120°F] and viscosity of 17.8 mm²/sec [88 SUS].

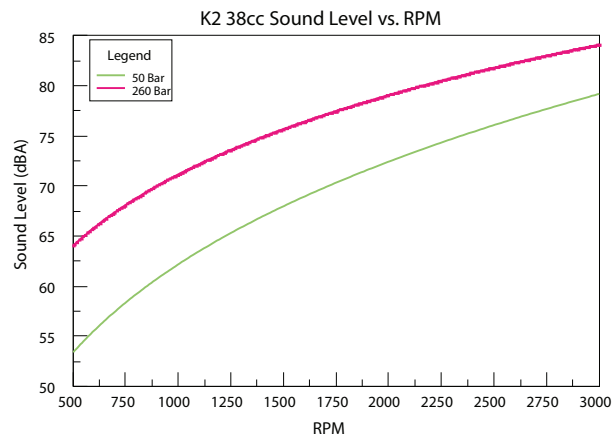
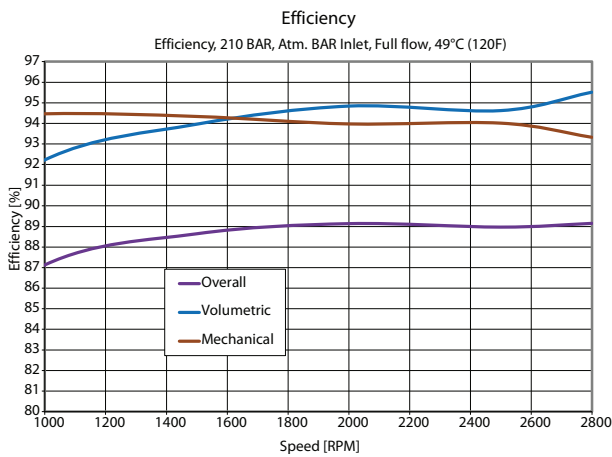
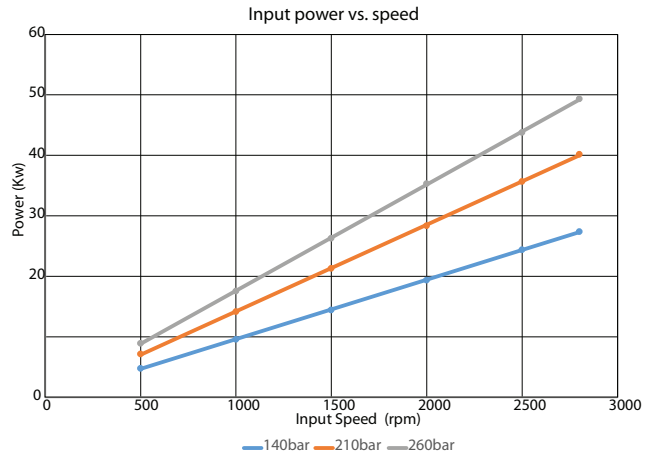
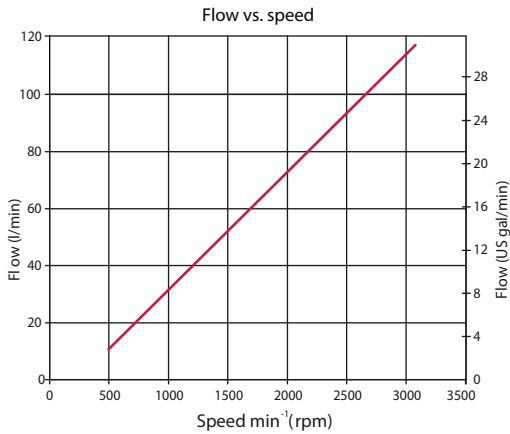

K2 Noise Level – 38cc kit @ 38cc Displacement

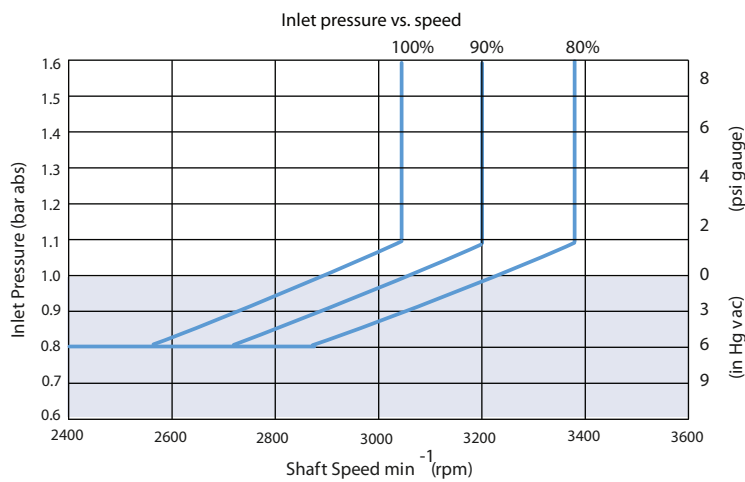

P109105

Frame K2

Performance K2-45C

Flow and power data valid at 49°C [120°F] and viscosity of 17.8 mm²/sec [88 SUS].

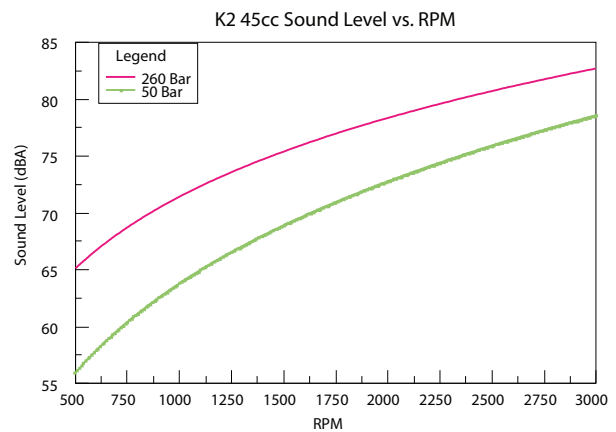
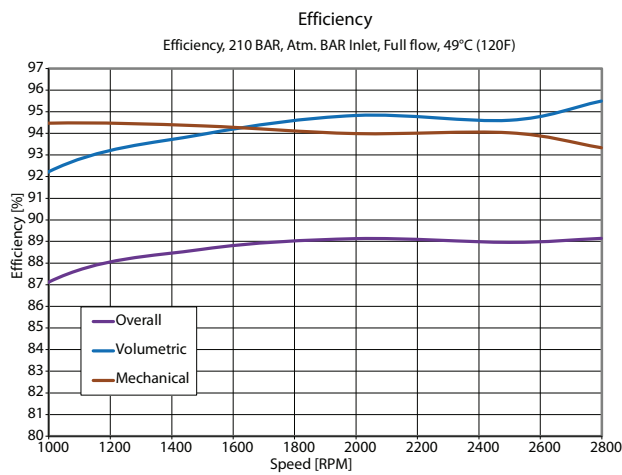
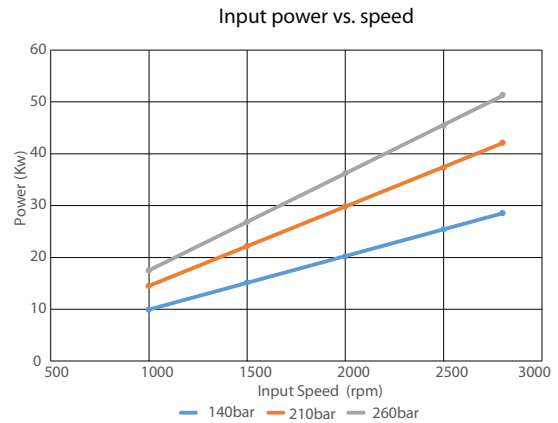
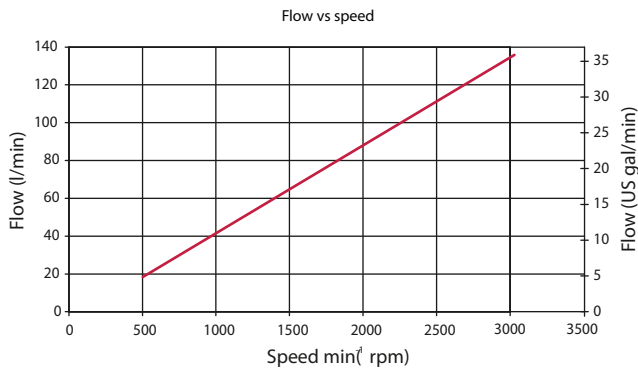

K2 Noise Level – 45cc kit @ 45cc Displacement

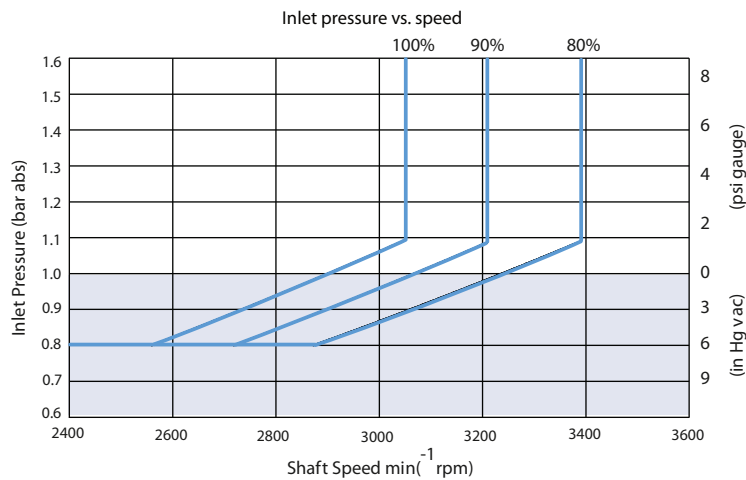

Frame K2

Hydraulic Controls

Pressure Compensated Controls

*Response/Recovery Times**

(msec)	Response	Recovery
25C	40	172
30C	44	152
38C	49	138
45C	49	138

PC Setting range

Model	Bar	Psi
25C	100-260	1450-3771
30C		
38C		
45C		

Schematic

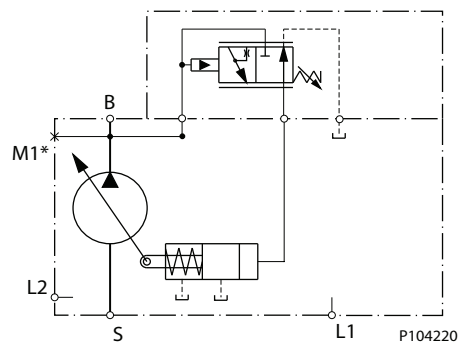

B = Outlet

S = Inlet

L1, L2 = Case drain

M1* = Gauge Port is available as an option. Standard products provided without a gauge port.

Frame K2

Remote Pressure Compensated Controls

*Response/Recovery Times**

(msec)	Response	Recovery
25C	40	172
35C	44	152
38C	49	138
45C	49	138

PC Setting Range

Model	RP
25C	100-260 bar [1450-3770 psi]
30C	100-260 bar [1450-3770 psi]
38C	100-260 bar [1450-3770 psi]
45C	100-260 bar [1450-3770 bar]

LS Setting range

Model	bar	psi
All	10-40	145-580

Schematic

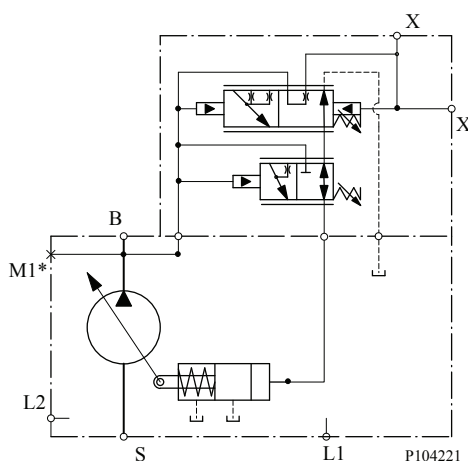

B = Outlet

S = Inlet

L1, L2 = Case drain

X = Remote PC port

M1* = Gauge Port is available as an option. Standard products provided without a gauge port.

Frame K2

Load Sensing Pressure Compensated Controls

*Response/Recovery Times**

(msec)	Response	Recovery
25C	40	172
30C	44	152
38C	49	138
45C	49	138

PC control setting range

Code	Bar	psi
25C	100-260	1450-3771
30C		
38C		
45C		

LS setting range

Model	bar	psi
All	10-40	145-580

Schematic

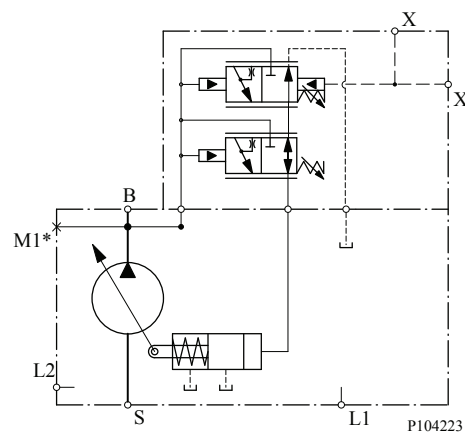

B = Outlet

S = Inlet

L1, L2 = Case drain

X = LS signal port

M1* = Gauge Port is available as an option. Standard products provided without a gauge port.

Frame K2

Load Sensing Control with Bleed Orifice /Pressure Compensated

*Response/Recovery Times**

(msec)	Response	Recovery
25C	40	172
30C	44	152
38C	49	138
45C	49	138

PC control setting range

Code	Bar	psi
25C	100-260	1450-3771
30C		
38C		
45C		

LS setting range

Model	bar	psi
All	10-40	145-580

Schematic

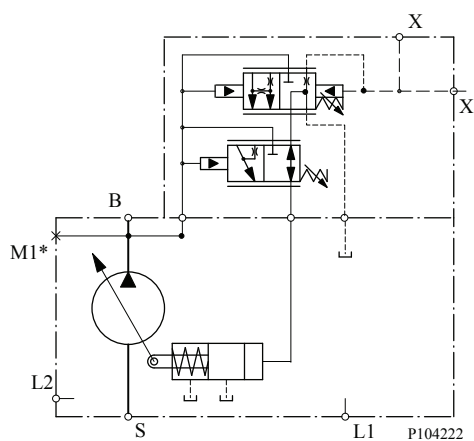

B = Outlet

S = Inlet

L1, L2 = Case drain

X = LS signal port

M1* = Gauge Port is available as an option. Standard products provided without a gauge port.

Frame K2

Electric Controls

Connectors

Description	Quantity	Ordering Number
Mating Connector	1	Deutsch® DT06-2S
Wedge Lock	1	Deutsch® W25
Socket Contact (16 and 18 AWG)	2	Deutsch® 0462-201-16141
Danfoss mating connector kit	1	K29657

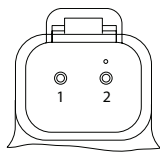

P003 480

Continuous Duty Operating Range

Continuous duty operating range

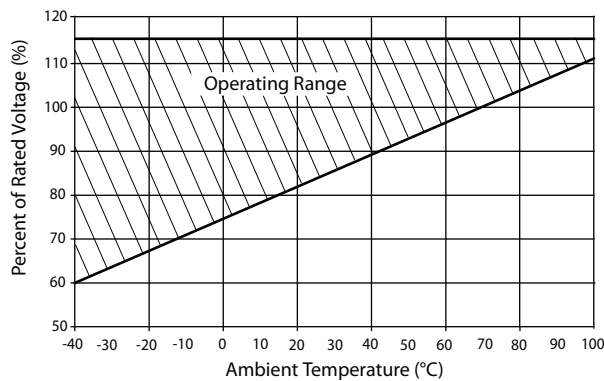

Solenoid Data - Normally Closed

Voltage	12V	24V
Threshold Control [mA] (310/260 bar PC setting, oil temp X)	200/400	100/200
End Current [mA] (20 bar LS setting, oil temp X)	1200	600

Solenoid Data - Normally Open

Voltage	12V	24V
Threshold Control [mA] (20 bar LS setting, oil temp X)	0	0
End Current [mA] (260/310 bar PC setting, oil temp X)	1000/1100	500/550

Frame K2

Normally Closed Electric On/Off with Pressure Compensation Controls

Voltage	12V	24V
Threshold Control [mA] (20 bar LS setting, oil temp X)	0	0
End Current [mA] (260/310 bar PC setting, oil temp X)	1000/1100	500/550

* Without servo control orifice

For fan-drive systems, and systems with motors, select an LS setting no less than 15 bar to enhance system stability. As the LS setting is reduced, the risk for system instability may be increased. A 20 bar LS setting is recommended as a starting point for all new applications.

Schematic

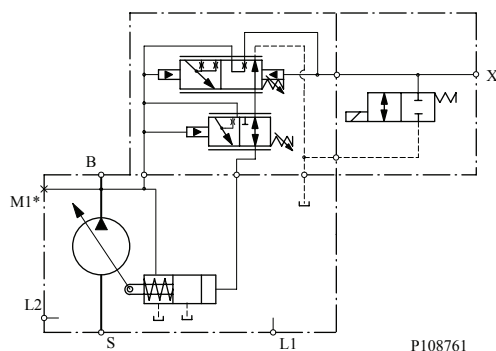

B = Outlet

S = Inlet

L1, L2 = Case drain

M1* = Gauge Port is available as an option. Standard products provided without a gauge port.

X = Load Sense Port

LS setting range

Model	bar	psi
All	10 - 40	[145 - 580]

PC setting range

Frame	AR (12V)	CR (24V)
25C	100-260 bar [1450-3770] psi	100-260 bar [1450-3770] psi
30C		
38C		
45C		

Frame K2

Normally Open Electric On/Off with Pressure Compensation Controls

*Response/Recovery times**

(msec)	Response	Recovery
25C	40	172
30C	44	152
38C	49	138
45C	49	138

* Without servo control orifice

For fan-drive systems, and systems with motors, select an LS setting no less than 15 bar to enhance system stability. As the LS setting is reduced, the risk for system instability may be increased. A 20 bar LS setting is recommended as a starting point for all new applications.

Schematic

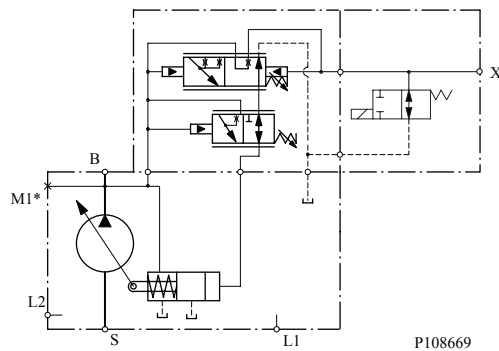

B = Outlet

S = Inlet

L1, L2 = Case drain

M1* = Gauge Port is available as an option. Standard products provided without a gauge port.

X = Load Sense Port

LS setting range

Model	bar	psi
All	10 - 40	[145 - 580]

PC setting range

Frame	AN (12V)	CN (24V)
25C	100-260 bar [1450-3770] psi	100-260 bar [1450-3770] psi
30C		
38C		
45C		

Frame K2

Normally Closed Electric Proportional with Pressure Compensation Controls

Response/Recovery times

(msec)	0.8mm Orifice		1.0mm Orifice	
	Response	Recovery	Response	Recovery
25C	85	518	79	358
30C	85	518	79	358
38C	85	518	79	358
45C	78	490	75	340

LS setting range

Model	bar	psi
All	10 - 40	[145 - 580]

Schematic

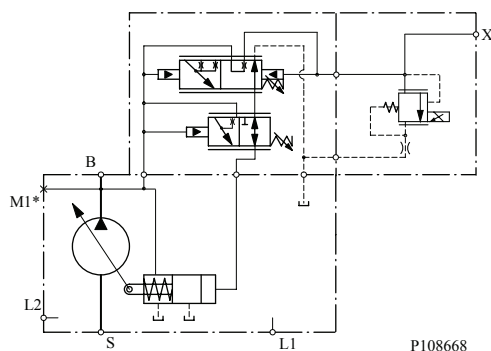

B = Outlet

S = Inlet

L1, L2 = Case drain

M1* = Gauge Port is available as an option. Standard products provided without a gauge port.

X = Load Sense Port

PC setting range

Frame	AH (12V)	AL (24V)
25C	100-260 bar [1450-3770] psi	100-260 bar [1450-3770] psi
30C		
38C		
45C		

For fan-drive systems, and systems with motors, select an LS setting no less than 15 bar to enhance system stability. As the LS setting is reduced, the risk for system instability may be increased. A 20 bar LS setting is recommended as a starting point for all new applications.

Electric proportional controls have a unique relationship between margin (LS) setting and low pressure standby. See the graph below for this relationship.

Frame K2

**Frames E, F, J Electric Proportional Control
 Low Pressure Standby**

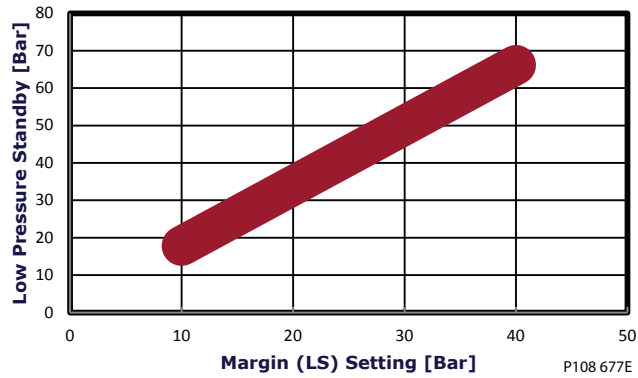

Normally Open Electric Proportional with Pressure Compensation Controls

Response/Recovery times

(msec)	0.8mm Orifice		1.0mm Orifice	
	Response	Recovery	Response	Recovery
25C	84	521	78	368
30C	84	521	78	368
38C	84	521	78	368
45C	81	498	74	343

LS setting range

Model	bar	psi
All	10 - 40	[145 - 580]

Schematic

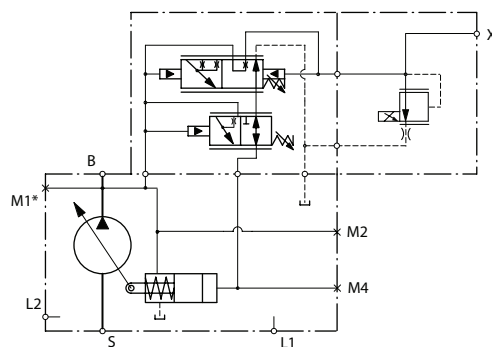

B = Outlet

S = Inlet

L1, L2 = Case drain

M1* = Gauge Port is available as an option. Standard products provided without a gauge port.

X = Load Sense Port

Frame K2

PC setting range

Frame	AX (12V)	CL (24V)
25C	100-260 bar [1450-3770] psi	100-260 bar [1450-3770] psi
30C		
38C		
45C		

For fan-drive systems, and systems with motors, select an LS setting no less than 15 bar to enhance system stability. As the LS setting is reduced, the risk for system instability may be increased. A 20 bar LS setting is recommended as a starting point for all new applications.

Electric proportional controls have a unique relationship between margin (LS) setting and low pressure standby. See the graph below for this relationship.

**Frames E, F, J, K2 Electric Proportional Control
 Low Pressure Standby**

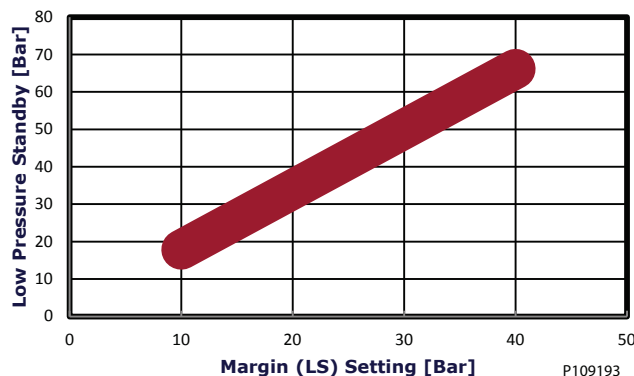

Normally Closed Fan Drive Control

PC setting range

Frame	SA (12V)	SC (12V)	SB (24V)	SD (24V)
25C	100-210 bar [1450-3045] psi	220-260 bar [3190-3771] psi	100-210 bar [1450-3045] psi	220-260 bar [3190-3771] psi
30C				
38C				
45C				

Frame K2

Fan Drive Control Schematic

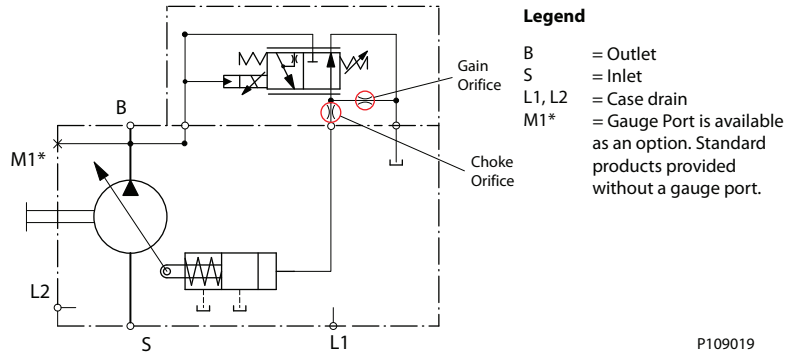

Input Shafts

Code	Description	Maximum torque rating ¹ N·m [lbf·in]	Drawing
C2	13 tooth spline 16/32 pitch (ANSI B92.1 1970 - Class 6e)	288 [2546]	<p>13 TOOTH 16/32 PITCH 30° PRESSURE ANGLE 20.638 [0.813] PITCH DA FILLET ROOTSIDE FT COMPATIBLE WITH ANSI B92.1-197 CLASS 6e ALSO MAT WITH FLATROOTSIDE FT</p> <p>Ø18.82 [0.74] MAX</p> <p>Ø21.72 ± 0.09 [0.855 ± 0.004]</p> <p>8 ± 0.475 [0.31 ± 0.02]</p> <p>15.2 ± 0.5 [0.6 ± 0.02]</p> <p>33 [1.3]</p> <p>COUPLING MUST NOT PROTRUDE BEYOND THIS POINT</p> <p>P101993E</p>
C3	15 tooth spline 16/32 pitch (ANSI B92.1 1970 - Class 6e)	404 [3575]	<p>15 TOOTH 16/32 PITCH 30° PRESSURE ANGLE 23.813 [0.938] PITCH DA FILLET ROOTSIDE FT COMPATIBLE WITH ANSI B92.1-197 CLASS 6e ALSO MAT WITH FLATROOTSIDE FT</p> <p>Ø21.92 MAX [0.863]</p> <p>Ø25.27 ± 0.12 [0.995 ± 0.005]</p> <p>8 ± 0.475 [0.31 ± 0.02]</p> <p>23.35 ± 0.5 [0.92 ± 0.02]</p> <p>38 [1.5]</p> <p>COUPLING MUST NOT PROTRUDE BEYOND THIS POINT</p> <p>P101994E</p>

Frame K2

Code	Description	Maximum torque rating ¹ N•m [lbf•in]	Drawing
K1	Ø 22.23 mm [0.875 in] 33 mm [1.3 in]	305 [2700]	<p>6.35 [0.25] x 12.7 [0.50] LONG SQUARE KE</p> <p>24.89⁺⁰_{-0.25} [0.98⁺⁰_{-0.01}]</p> <p>Ø22.2 ± 0.025 [0.874 ± 0.001]</p> <p>8 ± 0.8 [0.31 ± 0.03]</p> <p>33 [1.3]</p> <p>COUPLING MUST NOT PROTRUDE BEYOND THIS POINT</p> <p>P101 997E</p>
K2	Ø 22.23 mm [0.875 in] 63 mm [2.48 in] long	305 [2700]	<p>6.35 [0.25] x 38.1 [1.5] LONG SQUARE KE</p> <p>24.89⁺⁰_{-0.25} [0.98⁺⁰_{-0.01}]</p> <p>Ø22.2 ± 0.025 [0.874 ± 0.001]</p> <p>8 ± 0.3 [0.315 ± 0.035]</p> <p>63 [2.48]</p> <p>COUPLING MUST NOT PROTRUDE BEYOND THIS POINT</p> <p>P101 998E</p>

1. See [Input shaft torque ratings](#) for an explanation of maximum torque.

Frame K2

Installation Drawings

Axial Ported Endcap

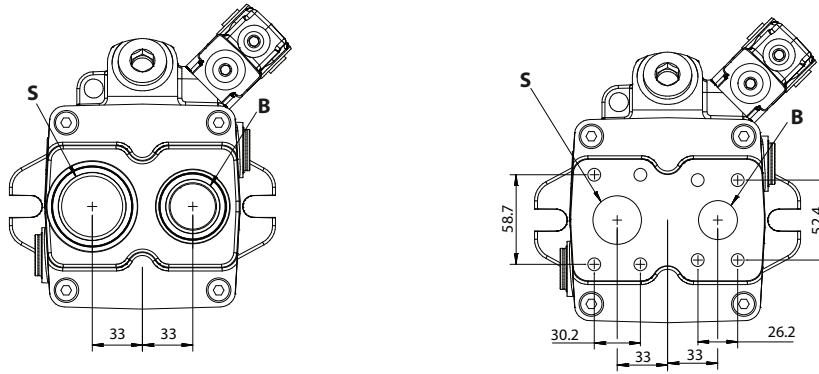

P109081

Code	Description	Port
S	System port (inlet), CW rotation shown	O-ring boss per ISO 6149-1, M48x2-6H or M42x2-6H Ø 31.8 - Split flange per ISO 6162-1, M10x1.5-6H 18 full thread depth
B	System port (outlet), CW rotation shown	O-ring boss per ISO 6149-1, M33x2-6H or M27x2-6H Ø 25.4 - Split flange per ISO 6162-1, M10x1.5-6H 18 full thread depth

Frame K2

Axial Ported Endcap Installation Dimensions

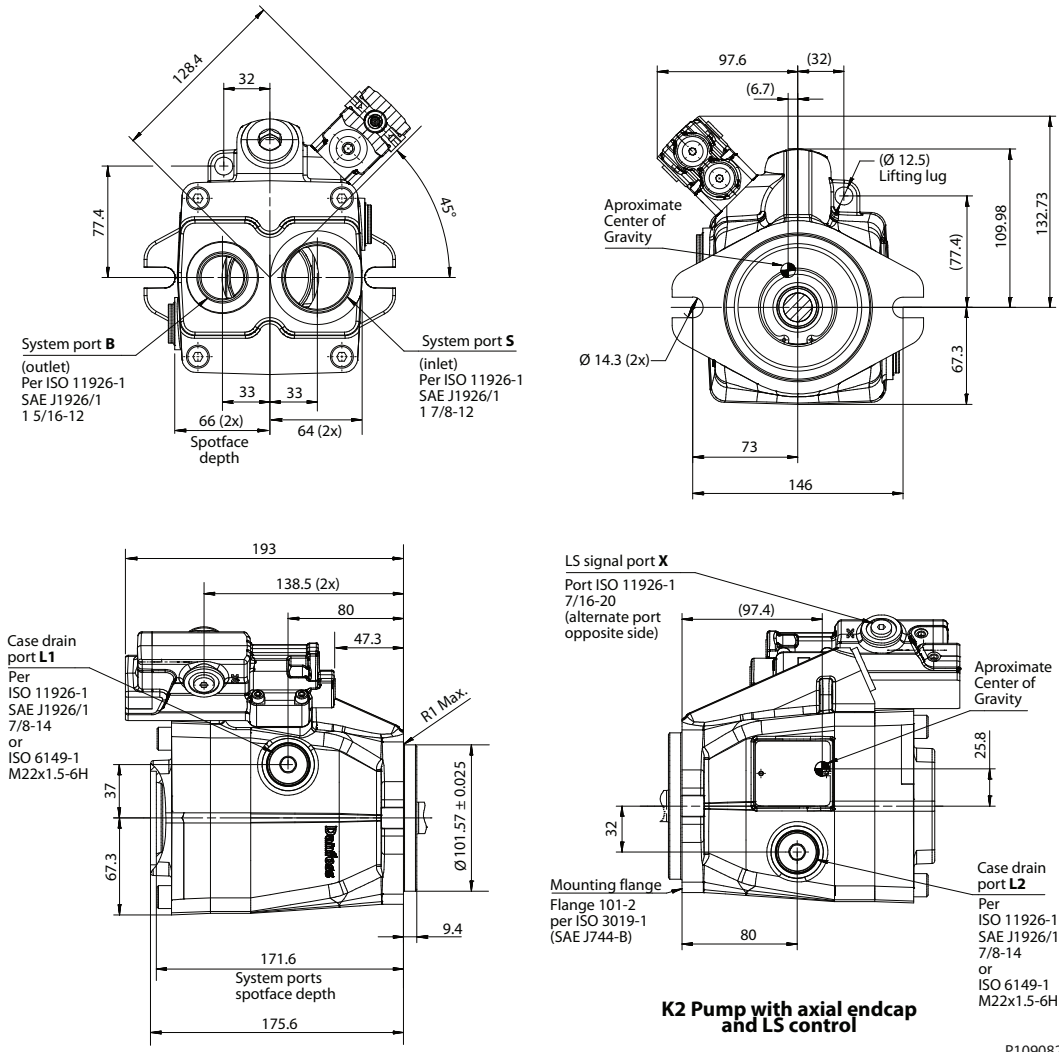

Radial Ported Endcap Split Flange Ports

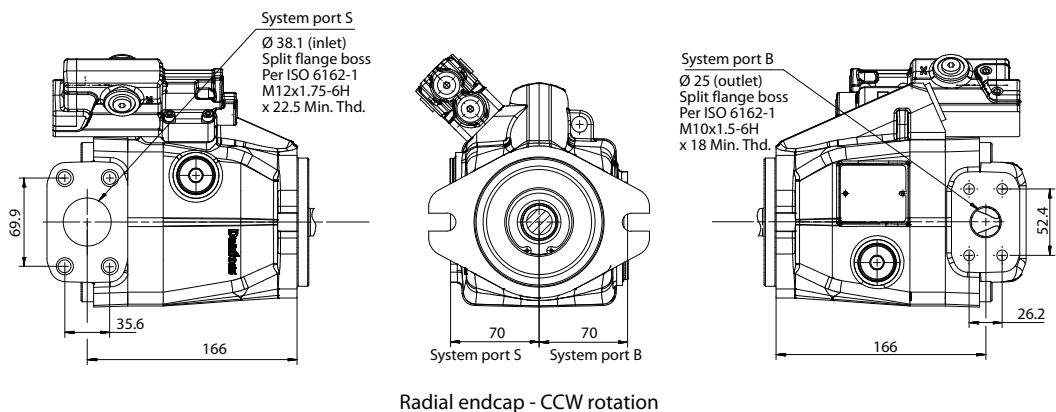

Frame K2

Radial Ported Endcap O-ring Boss Ports

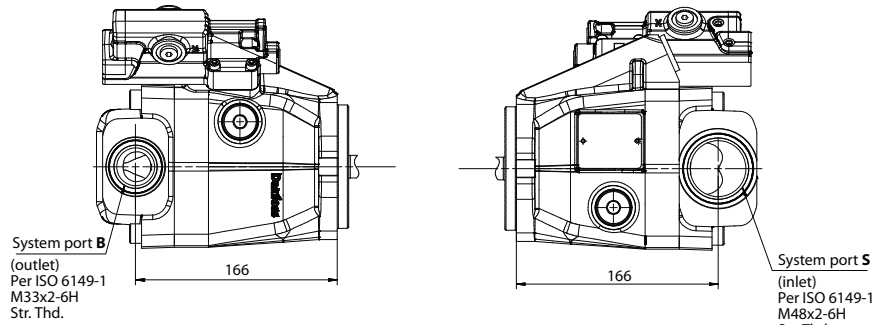

Radial endcap - CW rotation

P109088

Frame K2

Radial Ported Endcap Installation Dimensions

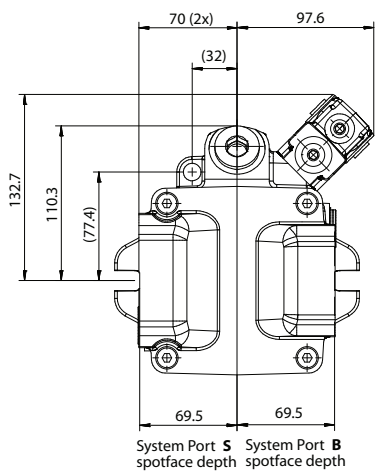
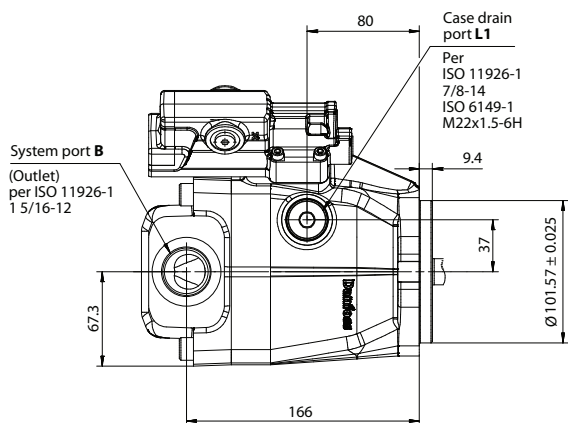
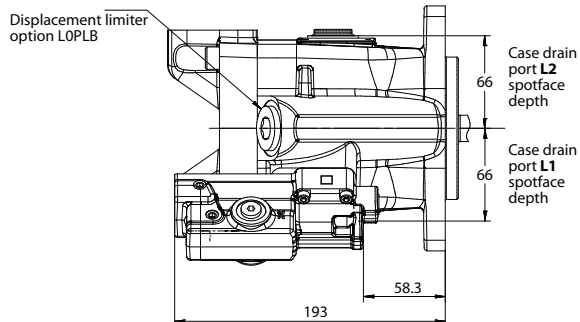

CW rotation with O-ring boss ports

Pump with radial endcap - non through drive

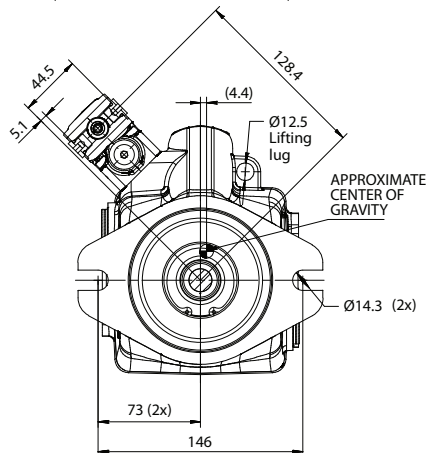
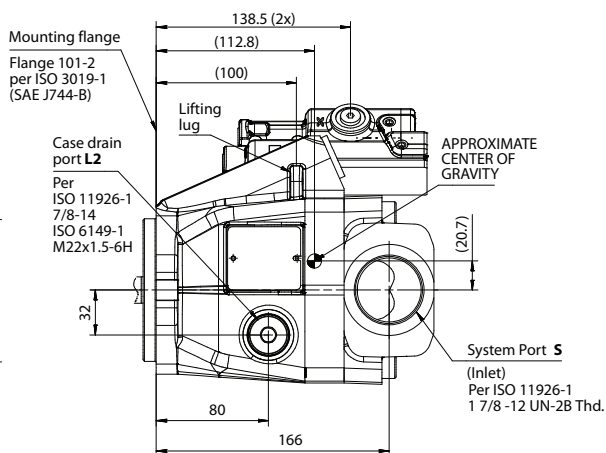

P109094

Front Mounting Flange - SAE-B two bolt

Frame K2

Auxiliary Mounting Pads

SAE-A auxiliary mounting pad

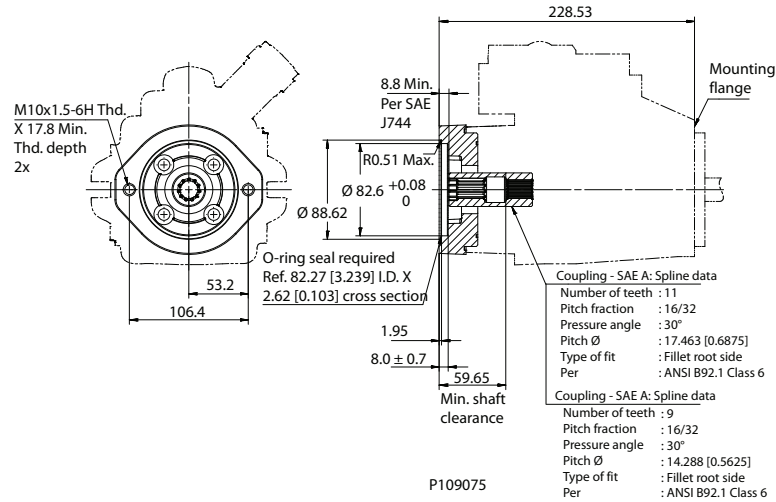

Specifications

Coupling	9-tooth	11-tooth
Spline minimum engagement	12.6 mm [0.50 in]	13.5 mm [0.53 in]
Maximum torque	107 N·m [950 lbf·in]	147 N·m [1300 lbf·in]

SAE-B auxiliary mounting pad

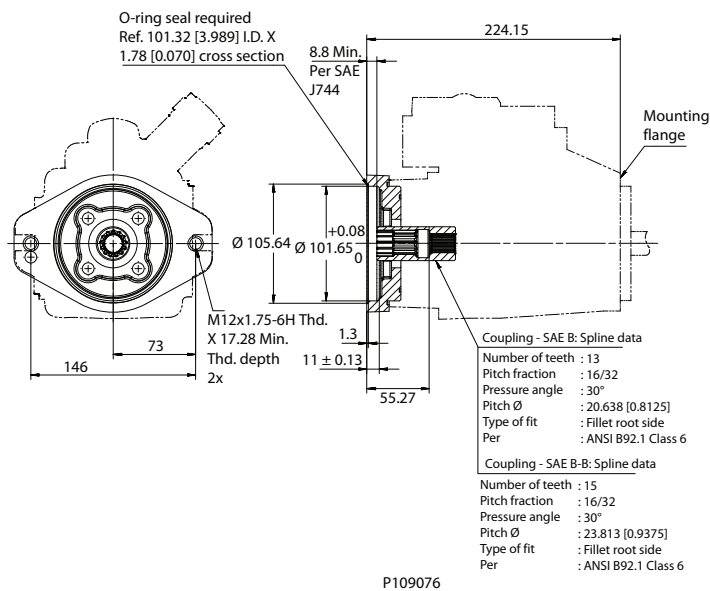

Frame K2

Specifications

Coupling	13-tooth	15-tooth
Spline minimum engagement	13.2 mm [0.52 in]	16.1 mm [0.63 in]
Maximum torque	171 N•m [1512 lbf•in]	171 N•m [1512 lbf•in]

SAE-A Fixed flange

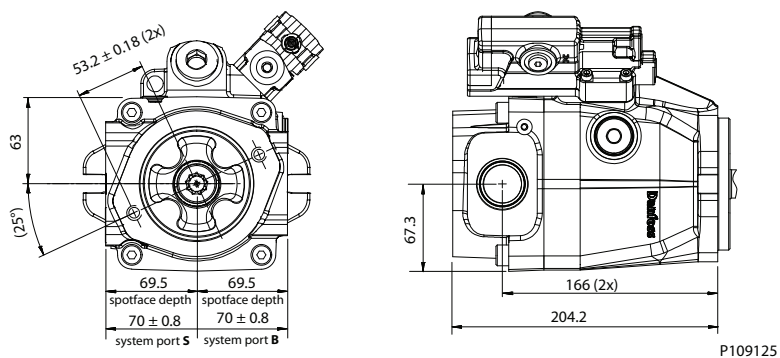

Auxiliary Mounting Pad - Running Cover

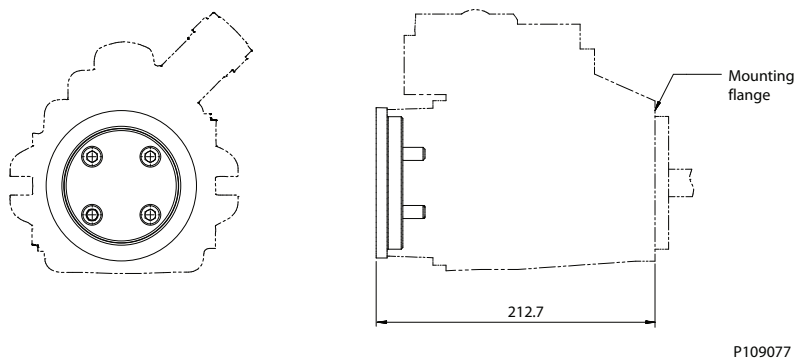

Frame K2

Electric solenoid, left side

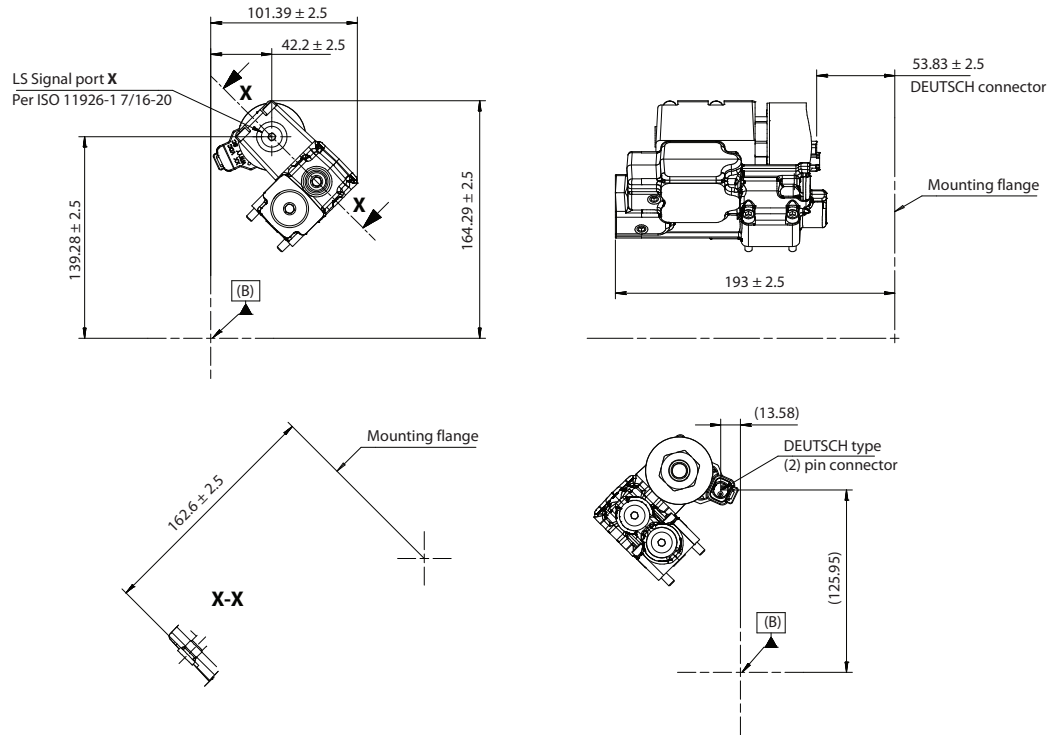

Single pool control, Left side

P109096

Electric solenoid, De-stroking On/Off

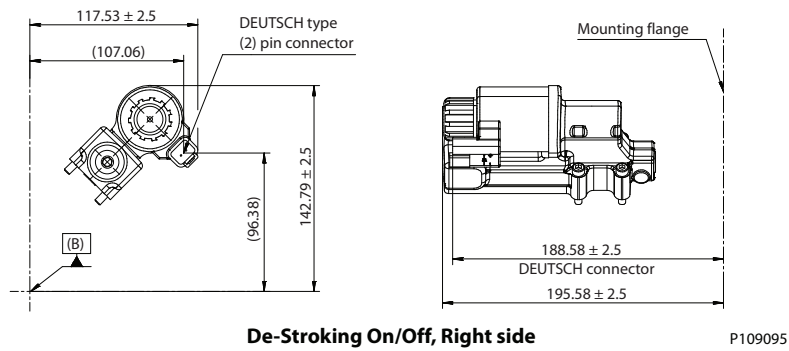

De-Stroking On/Off, Right side

P109095