



**SAP DIN Optimised is a series of piston pumps with a fixed displacement for demanding mobile hydraulics.**

SAP 084, 108 DIN Optimised covers the displacement range 84 and 108 cm<sup>3</sup>/rev. at a maximum pressure of 400 bar. It is a modern, compact pump which meets the market's high demands on flow performance, pressure, efficiency and small installation dimensions. It is either mounted directly on the power take-off or on a frame bracket via an intermediate shaft.

It is a speed-optimised pump and are therefore supplied for either left (L) or right (R) rotation direction.

The front seals in the pump are made of HNBR to withstand the higher temperatures that occur at engine PTO mounting.

**Other advantages:**

- Light weight metal casing design
- Smooth operation over the entire speed range
- Long life due to high demands on material selection, such as bearings, seals, etc
- Corrosion free light metal-housing
- Less heat generation due to better ability to dissipate heat through housing

## Versions, main data

Example

SA	P	-	084	L	-	V	-	DL4	-	L35	-	S0	S	-	2	00
Line	1		2	3		4		5		6		7	8		9	10

Line	SA	Sunfab Aluminium
------	----	------------------

1. Type	P	Pump
---------	---	------

2. Displacement	084	108
-----------------	-----	-----

3. Direction of rotation	R	Right
	L	Left

4. Sealing	V	HNBR
------------	---	------

5. Mounting flange	DL4	DIN 4-h (ISO 7653D)
--------------------	-----	---------------------

6. Shaft	L35	DIN 5462 / ISO 14
----------	-----	-------------------

7.	S0	40° Sunfab standard
----	----	---------------------

8. Connections	S	Sunfab standard
----------------	---	-----------------

9. Additional	2	Optimised
---------------	---	-----------

10. Accessories	00	No accessories available
-----------------	----	--------------------------

**Pump SAP 084, 108 DIN Optimised**

		084	108
Theoretical oil flow l/min at pump speed			
	rpm	500	41.8
		1000	83.6
		1500	125.4
Displacement	cm <sup>3</sup> /rev	83.6	108.0
Max pump speed			
	rpm	1800	1800
continuous		2300	2300
limited			
Max working pressure	bar	400	400
Weight	kg	13.9	13.9
Tare-weight torque (M)	Nm	18.0	18.0
Direction of rotation	Left (L) or Right (R)		

# Dimensions SAP 084-108, SAPT 130

Millimeter (inch)

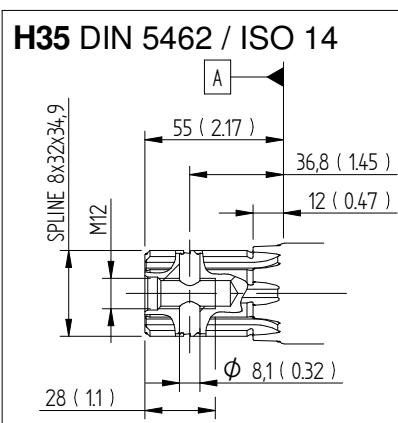
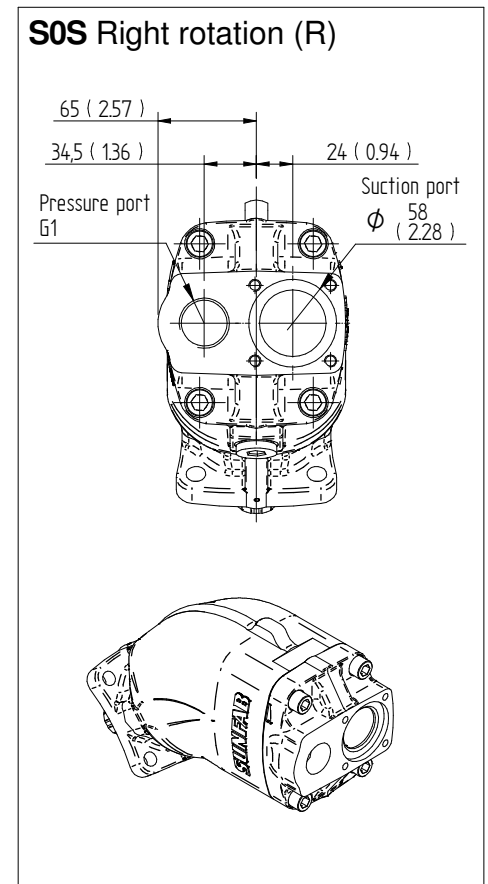
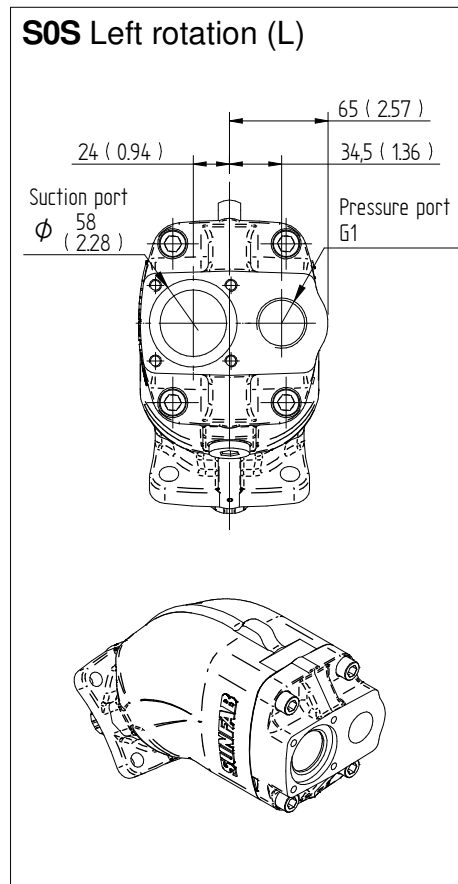
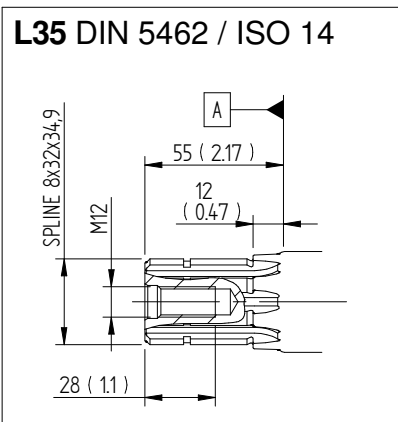
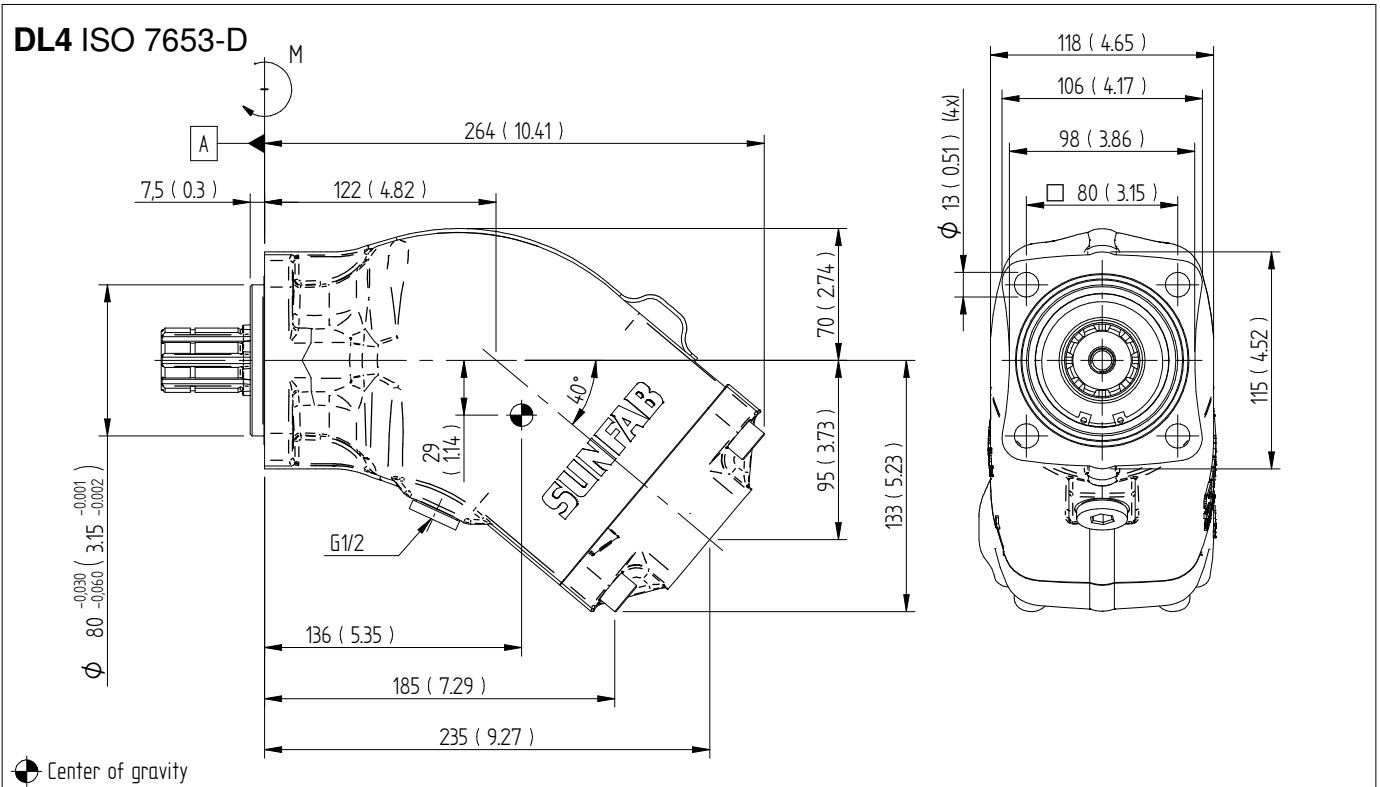



**WARNING!**

When the pump is running:

1. Do not touch the pressure hose
2. Watch out for rotating parts
3. The pump and hoses may be hot

Sunfab reserves the right to make changes in design and dimensions without notice. Printing and typesetting errors reserved.

© Copyright 2019 Sunfab Hydraulics AB. All Rights Reserved.