

N°8 M10x22
N°8 per parte
N°4 Each side

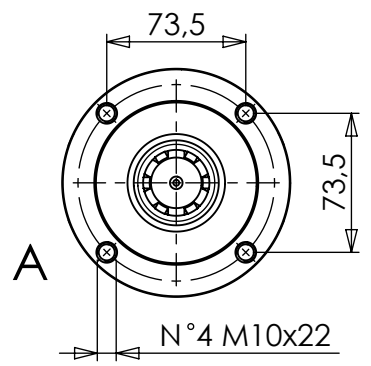

WARNING!

ROTATING SHAFTS MARKED
ARE NOT SHIELDED.
ANY SHAFT AND COUPLING NOT GUARDED
BY LOCATION MUST BE SHIELDED
BY AN INTERACTIVE GUARDING SYSTEM.
BONDIOLI & PAVESI DECLINES
RESPONSIBILITY IF PROPER GUARDS
ARE NOT PROVIDED AND MAINTAINED.

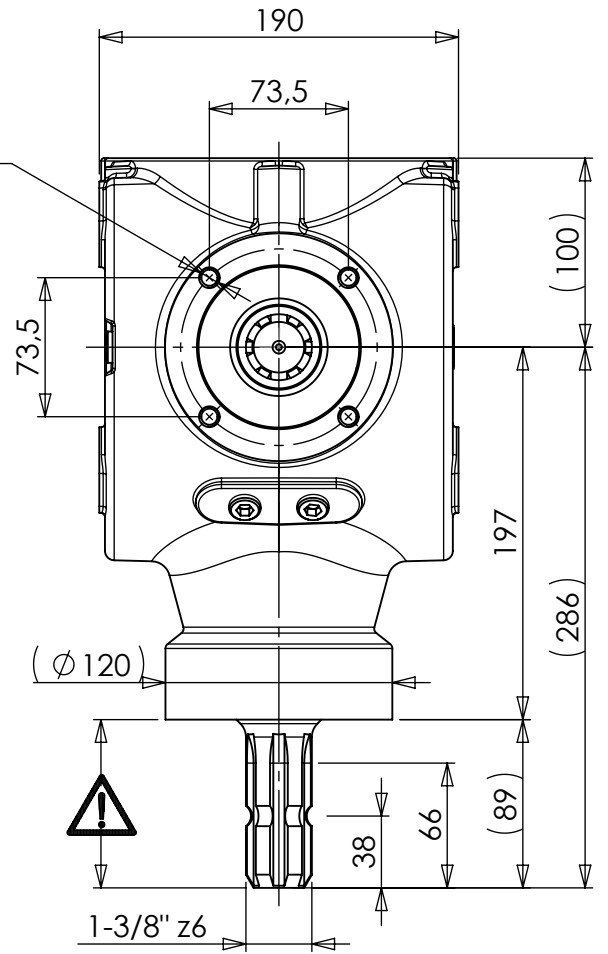

A	Rifatto disegno. / Remade drawing.	05/09/2022	Raffaldoni M.
Rev.	Descrizione / Description	Data / Date	Disegnato / Drawn by

MONTAGGIO / GEAR ARRANGEMENTS 	RAPPORTO / RATIO	TIPO / TYPE	CLIENTE / CUSTOMER			
	2.30:1	2100	TIPO DI MACCHINA / TYPE OF IMPLEMENT	PESO / WEIGHT (Kp)		DESEGNATO / DESIGNED BY
	GIRI IN ENTRATA / INPUT SPEED	540	30.3	Vezzani f.		
POTENZA IN ENTRATA / INPUT POWER	35 CV - 26 kW	RIF.CLIENTE / CUSTOMER REF.	DATA / DATE	CODICE / CODE		
			25-10-2002	S2100230R110	REV. A	

QUESTO DISEGNO CONTIENE INFORMAZIONI RISERVATE. LA RIPRODUZIONE TOTALE O PARZIALE È VIETATA SENZA PREVIO ACCORDO SCRITTO CON BONDIOLI & PAVESI.

THIS DRAWING CONTAINS CONFIDENTIAL INFORMATION. REPRODUCTION IN WHOLE OR IN PART IS PROHIBITED WITHOUT PRIOR WRITTEN AGREEMENT WITH BONDIOLI & PAVESI.