



PDE3

PROPORTIONAL PRESSURE RELIEF VALVE, DIRECT OPERATED SERIES 10

**SUBPLATE MOUNTING
ISO 4401-03**

**p max 350 bar
Q max 2 l/min**

MOUNTING SURFACE

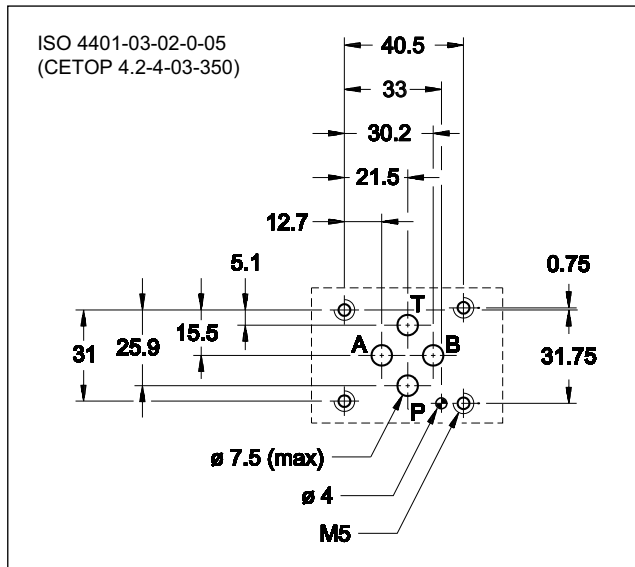

PERFORMANCES

(obtained with mineral oil with viscosity of 36 cSt at 50°C and electronic control card)

Maximum operating pressure: - P port - T port	bar	350 2
Minimum controlled pressure	see p min = f(Q) diagram	
Nominal flow Maximum flow (see p min = f(Q) diagram)	l/min	1 2
Step response	see paragraph 6	
Hysteresis (with PWM 200 Hz)	% of p nom	< 5%
Repeatability	% of p nom	< ±1,5%
Electrical characteristic	see paragraph 5	
Ambient temperature range	°C	-20 / +60
Fluid temperature range	°C	-20 / +80
Fluid viscosity range	cSt	10 ÷ 400
Fluid contamination degree	According to ISO 4406:1999 class 18/16/13	
Recommended viscosity	cSt	25
Mass	kg	1,6

OPERATING PRINCIPLE

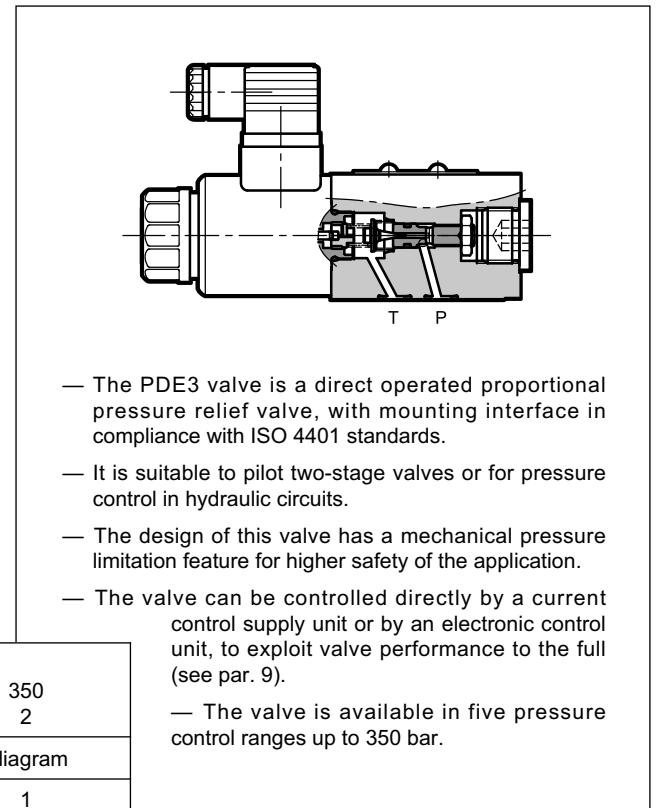

HYDRAULIC SYMBOL

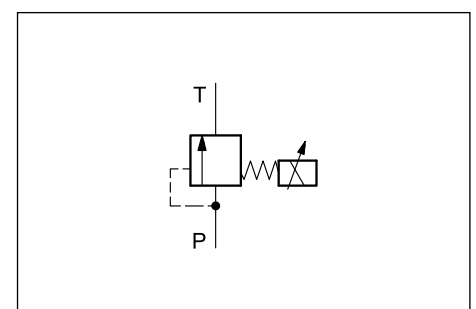

1 - IDENTIFICATION CODE

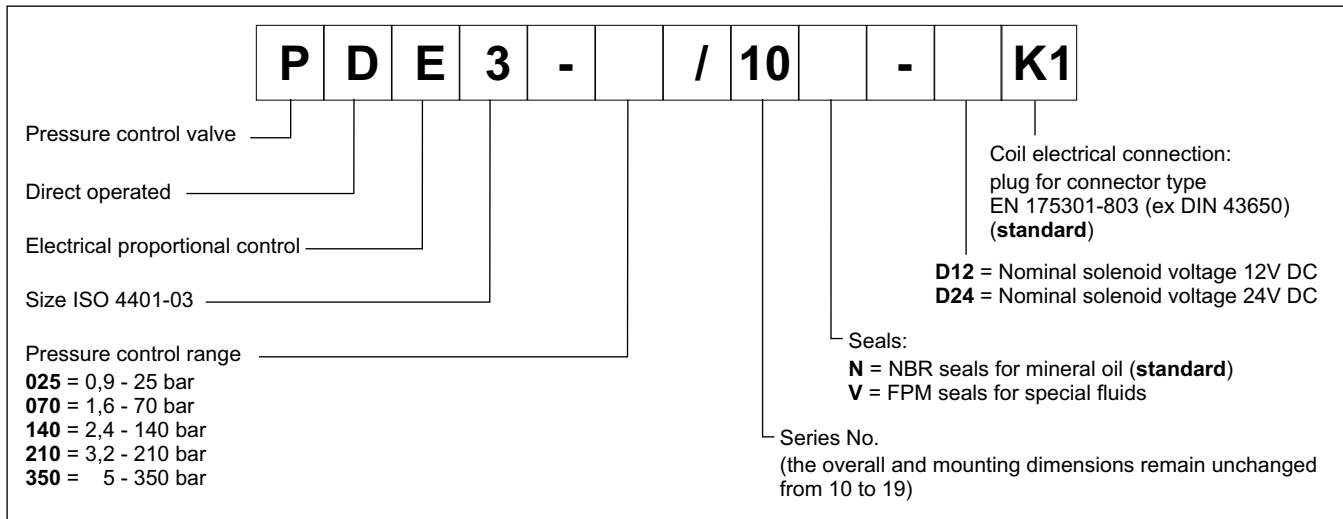

2 - CHARACTERISTIC CURVES

(obtained with viscosity of 36 cSt at 50°C, and valves with D24 coil)

Typical control curves according to the current supplied to the solenoid, measured with input flow rate $Q = 1$ l/min.

Curves have been obtained without any hysteresis and linearity compensation and they are measured without any backpressure in T. The full scale pressure is set in factory with a flow rate of 1 l/min. In case of higher flow rate, the full scale pressure will increase considerably (see diagram $p_{max} = f(Q)$).

PRESSURE CONTROL $p = f(I)$

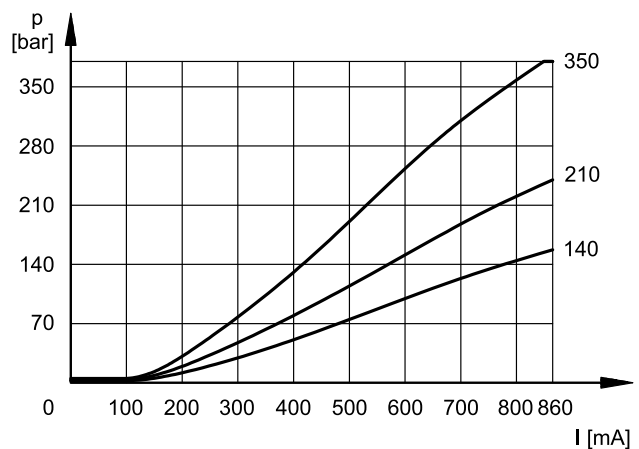
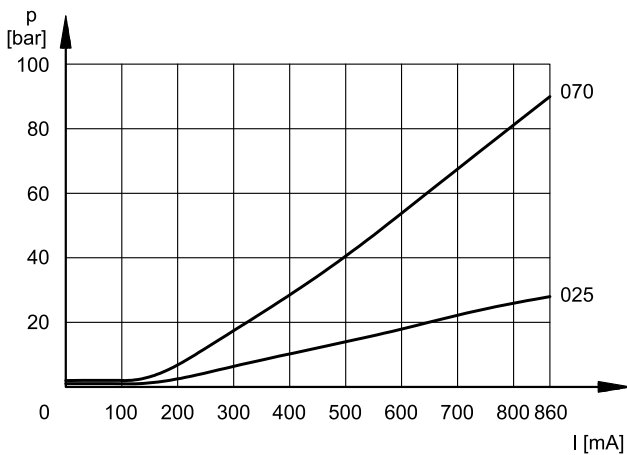

MINIMUM CONTROLLED PRESSURE $p_{min} = f(Q)$

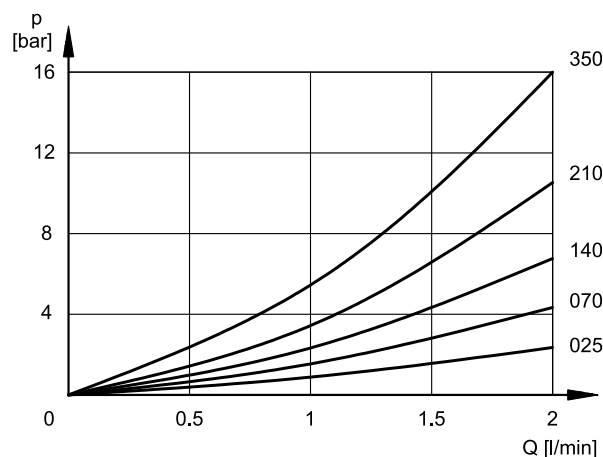

PRESSURE VARIATION $p_{max} = f(Q)$

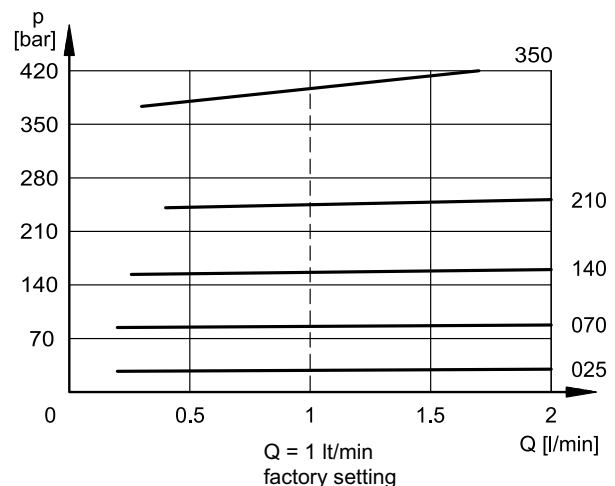

3 - MAX PRESSURE VALUES

This valve incorporates a mechanical limit of the maximum pressure, that operates independently of the applied current. This kind of design ensures that the pressure cannot rise over even if the solenoid current exceeds the maximum current ($I > I_{max}$).

Values obtained with oil viscosity of 36 cSt at 50°C, Q = 1 l/min

		PDE3-025	PDE3-070	PDE3-140	PDE3-210	PDE3-350
pressure value at 800 mA	bar	25	77	142	217	360
max pressure value when $I > I_{max}$	bar	33,5	90	161	252	390

4 - HYDRAULIC FLUIDS

Use mineral oil-based hydraulic fluids HL or HM type, according to ISO 6743-4. For these fluids, use NBR seals (code N). For fluids HFDR type (phosphate esters) use FPM seals (code V). For the use of other kinds of fluid such as HFA, HFB, HFC, please consult our technical department.

Using fluids at temperatures higher than 80 °C causes a faster degradation of the fluid and of the seals characteristics. The fluid must be preserved in its physical and chemical characteristics.

5 - ELECTRICAL CHARACTERISTICS

Proportional solenoid

The proportional solenoid comprises two parts: tube and coil.

The tube, screwed to the valve body, contains the armature which is designed to maintain friction to a minimum thereby reducing hysteresis.

The coil is mounted on the tube secured by means of a lock nut and can be rotated through 360° depending on installation clearances.

NOMINAL VOLTAGE	V DC	12	24
RESISTANCE (at 20°C)	Ω	3.66	17.6
NOMINAL CURRENT	A	1.88	0.86
DUTY CYCLE	100%		
ELECTROMAGNETIC COMPATIBILITY (EMC)	According to 2014/30/EU		
CLASS OF PROTECTION atmospheric agents (EN 60529) coil insulation (VDE 0580) Impregnation	IP65 class H class F		

6 - STEP RESPONSE

(obtained with mineral oil with viscosity of 36 cSt at 50°C and electronic control card)

Step response is the time taken for the valve to reach 90% of the set pressure value following a step change of reference signal.

The table illustrates typical step response times measured with a PDE3-210 and with an input flow rate of Q = 1 l/min and pressure oil volume of 0,1 litre. The response time is affected both by the flow rate and the oil volume in the pipework.

REFERENCE SIGNAL STEP	0 → 100%	100 → 0%
Step response [ms]	60	70

7 - INSTALLATION

We recommend installing these valves with the solenoid downward, either in horizontal or vertical position. If the valve is installed on vertical axis with the solenoid upward, you should consider possible variations of the minimum controlled pressure from those indicated in paragraph 2.

Ensure that there is no air in the hydraulic circuit. In certain applications it might be necessary to vent the air entrapped in the solenoid tube by unfastening the drain screw placed in the solenoid tube.

Ensure the solenoid tube is always filled with oil. Make sure the drain screw has been put back correctly at the end of the task.

Connect the valve T port directly to the tank. **Add any backpressure value detected in the T line to the controlled pressure value.**

Maximum admissible backpressure in the T line, under operational conditions, is 2 bar.

Valves are fixed by means of screws or tie rods on a flat surface with planarity and roughness equal to or better than those indicated in the relative symbols.

If minimum values are not observed, fluid can easily leaks between the valve and support surface.

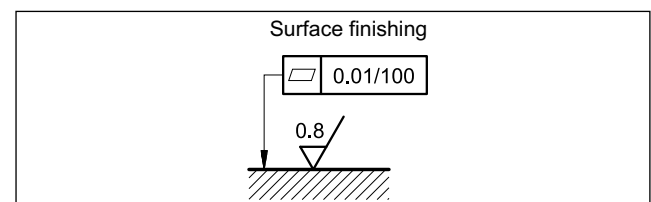

8 - OVERALL AND MOUNTING DIMENSIONS

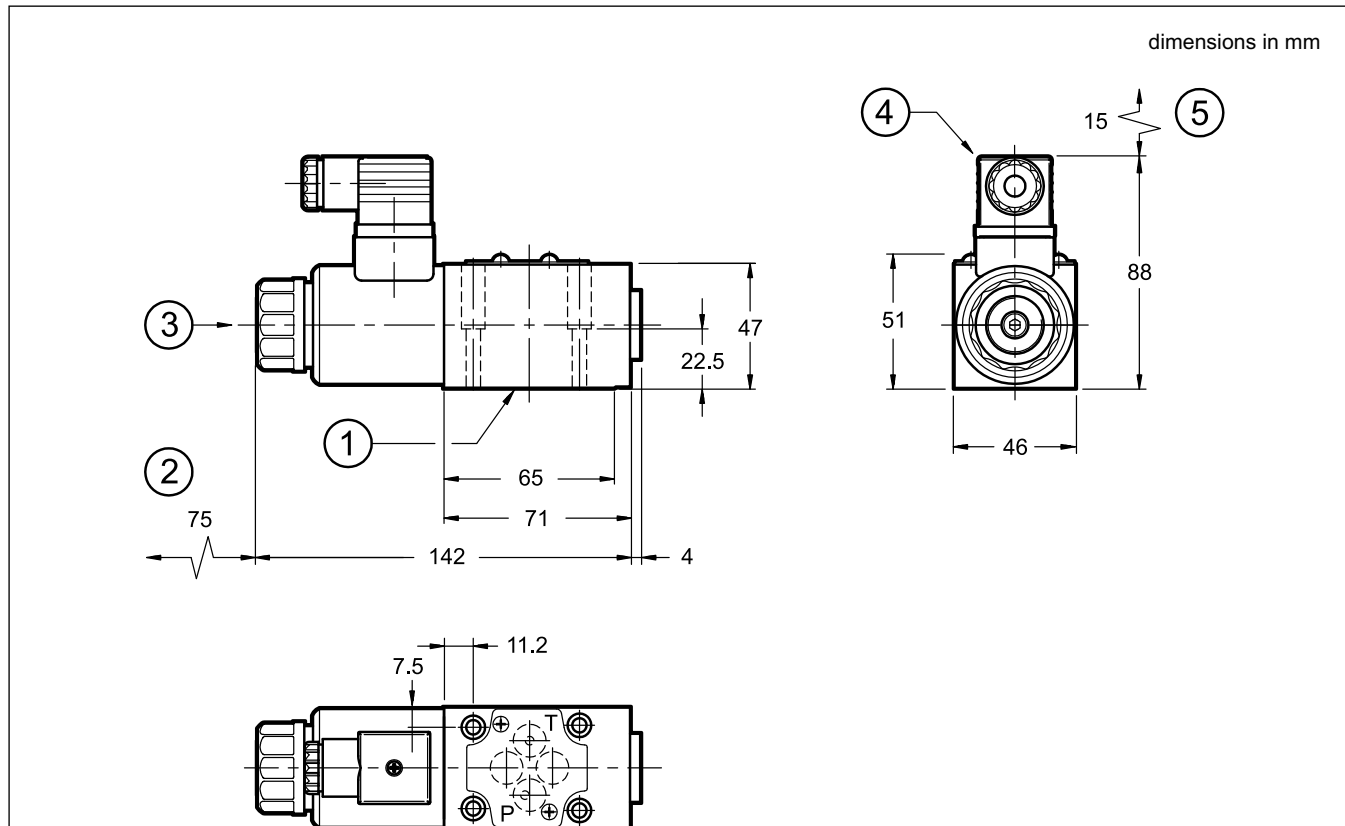

NOTE: at the first start up, or after a long period of no use, it is necessary to vent the air through the breather (3) placed at the end of the solenoid tube.

1	Mounting surface with sealing rings: 4 OR type 2037 (9.25 x 1.78) - 90 shore
2	Coil removal space
3	Breather (Allen key 4)
4	EN 175301-803 (ex DIN 43650) connector, included in the supply
5	Connector removal space

Valve fastening: 4 SHC screws M5x30 - ISO 4762
Tightening torque: 5 Nm (A 8.8 screws)
Threads of mounting holes: M5x10

9 - ELECTRONIC CONTROL UNITS

EDC-112	for solenoid 24V DC	plug version	see cat. 89 120
EDC-142	for solenoid 12V DC		
EDM-M112	for solenoid 24V DC	DIN EN 50022 rail mounting	see cat. 89 251
EDM-M142	for solenoid 12V DC		

10 - SUBPLATES

(see catalogue 51 000)

PMMD-AI3G with ports on rear
PMMD-AL3G with side ports
Ports dimensions: P, T, A, B: 3/8" BSP thread