



**BREVINI<sup>®</sup>**

*Motion Systems*

## LOW SPEED HIGH TORQUE ORBITAL MOTORS

March  
**2018**







**BREVINI<sup>®</sup>**

*Motion Systems*

## **INDICE / INDEX**

<b>INFORMAZIONI GENERALI / GENERAL INFORMATION</b>	pag. A/1
<b>BGM</b> <i>Motori orbitali / Orbital motors</i>	pag. B/1
<b>BG - BH</b> <i>Motori orbitali / Orbital motors</i>	pag. C/1
<b>AR</b> <i>Motori orbitali / Orbital motors</i>	pag. D/1
<b>BR - BS</b> <i>Motori orbitali / Orbital motors</i>	pag. E/1
<b>HR</b> <i>Motori orbitali / Orbital motors</i>	pag. F/1
<b>HT</b> <i>Motori orbitali / Orbital motors</i>	pag. G/1
<b>BRZ</b> <i>Motori orbitali / Orbital motors</i>	pag. H/1
<b>VALVOLE ED ACCESSORI / VALVES AND ACCESSORIES</b>	pag. I/1

© 2018 Dana Brevini fluid power S.p.A. Tutti i diritti riservati. Hydr-App, SAM Hydraulik, Aron, Brevini Hydraulics, BPE Electronics, VPS Brevini, OT Oiltechnology, sono marchi o marchi registrati di Dana Brevini fluid power S.p.A. o da altre società del Gruppo Dana in Italia ed in altri paesi.

Le caratteristiche tecniche fornite nel presente catalogo non sono impegnative e non sarà possibile basare alcun procedimento legale su tale materiale. Dana Brevini fluid power non sarà responsabile per informazioni e specifiche che possano indurre ad errori o errate interpretazioni. Data la continua ricerca tecnologica volta a migliorare le caratteristiche tecniche dei nostri prodotti, Dana Brevini fluid power si riserva il diritto di apportarvi senza alcun preavviso le modifiche che riterrà opportuno. E' vietata la riproduzione anche parziale senza la specifica autorizzazione scritta di Dana Brevini fluid power. Questo catalogo sostituisce i precedenti.

L'utilizzo dei prodotti riportati su questo catalogo deve essere effettuato nel rispetto dei limiti di funzionamento riportati nelle specifiche tecniche, valutando il tipo di applicazione e le condizioni di funzionamento normali o in caso di avaria, in modo da non pregiudicare la sicurezza di persone e/o cose.

© 2018 Dana Brevini fluid power S.p.A. All rights reserved. Hydr-App, SAM Hydraulik, Aron, Brevini Hydraulics, BPE Electronics, VPS Brevini, OT Oiltechnology, logos are trademarks or are registered trademarks of Dana Brevini fluid power S.p.A. or other companies of the Dana Group in Italy and other countries.

The technical features supplied in this catalogue are non binding and no legal action can be taken against such material. Dana Brevini fluid power will not be held responsible for information and specifications which may lead to error or incorrect interpretations. Given the continuous technical research aimed at improved technical features of our products, Dana Brevini fluid power reserves the right to make change that are considered appropriate without any prior notice. This catalogue cannot be reproduced (in whole or in part) without the prior written consent of Dana Brevini fluid power. This catalogue supersedes all previous ones.

Use of the products in this catalogue must comply with the operating limits given in the technical specifications. The type of application and operating conditions must be assessed as normal or in malfunction in order to avoid endangering the safety of people and/or items.





**BREVINI<sup>®</sup>**

*Motion Systems*

---

## **INFORMAZIONI GENERALI**

---

## **GENERAL INFORMATION**

---

## MOTORI IDRAULICI

### Principio di funzionamento

I motori idraulici trasformano l'energia idraulica (pressione, portata) in energia meccanica (coppia, numero di giri).

Tale trasformazione, nei motori orbitali avviene nell'organo motore gruppo orbitale costituito da uno statore esterno con dentatura interna ed un rotore (a moto epicicloidale) di profilo appropriato. I motori orbitali sono a cilindrata fissa.

### GRUPPO ORBITALE

Vi sono due versioni del gruppo orbitale: i motori dei tipi BGM, BG, BH hanno lo statore con dentatura a profilo piano (gerotor: fig. 1 a-b), mentre nei motori dei tipi BR, BS, ARS, ARF, HR e HT i denti dello statore sono realizzati con rullini (roller: fig. 1 c-d-e).

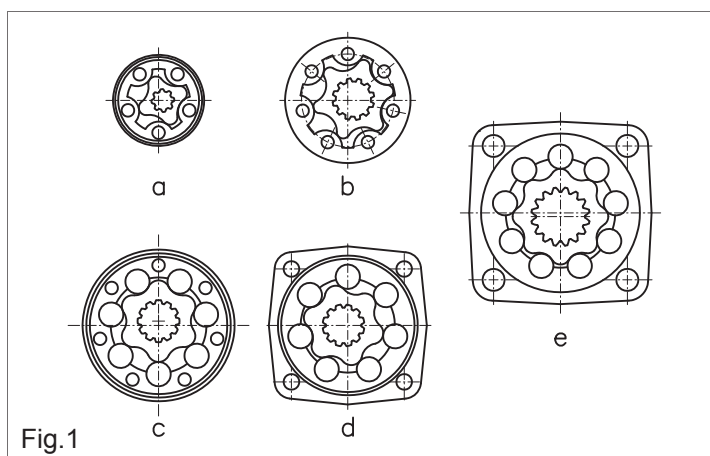

Fig.1

## DISTRIBUTORI

Nei motori orbitali la trasmissione del moto tra il rotore, l'albero motore e il distributore avviene tramite un albero cardanico che assicura il sincronismo tra il distributore e il gruppo orbitale.

Vi sono tre tipi di distributori:

### – Albero distributore

I motori BGM, BG, BH, BR e BS hanno una distribuzione radiale ricavata direttamente sull'albero d'uscita (fig. 2).

### – Distributore a disco compensato

I motori ARS e ARF hanno un distributore a disco compensato idraulicamente collegato all'albero d'uscita tramite un giunto Oldham (fig. 3).

### – Distributore a disco compensato indipendente.

I motori HR e HT hanno un distributore a disco idraulicamente compensato e separato dall'albero d'uscita. Il distributore è trascinato da un piccolo albero cardanico (fig. 4).

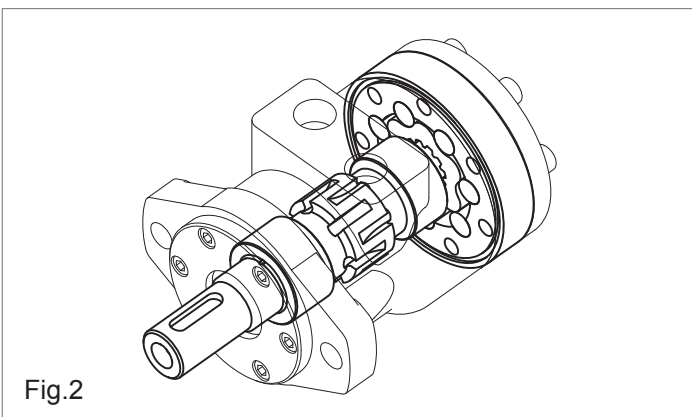

Fig.2

## HYDRAULIC MOTORS

### Operating principle

Hydraulic motors convert hydraulic energy (pressure, oil flow) into mechanical energy (torque, revolutions).

In the case of orbital motors, this conversion is made by the drive component (orbital unit): an external stator with internal toothing and a rotor (with planetary motion) of suitable profile. Our orbital motors have fixed displacement.

### GEARWHEEL SET

There are two types of gearing: the BGM, BG, and BH have gears with matching profiles (Gerotor gear set: fig. 1 a-b), whereas the BR, BS, ARS, ARF, HR and HT have rollers between the two gears (Geroller gear set: fig. 1 c-d-e).

## TIMING VALVE

In orbital motors the motor shaft and timing valve are driven by a cardan shaft that ensures the synchronism between the gearwheel set and the fluid timing valve.

There are three types of timing valve:

### – Spool valve

BGM, BG, BH, BR and BS motors have a spool valve: the timing valve has been integrated in the output shaft design (fig. 2).

### – Pressure compensated valve plate

ARS and ARF motors have a pressure compensated valve plate: The timing valve is driven by the output shaft through an Oldham type coupling (fig. 3).

### – Separated pressure compensated valve plate.

HR and HT motors have a disc valve, hydraulically compensated and separately driven by a dedicated Cardan type coupling (fig. 4).

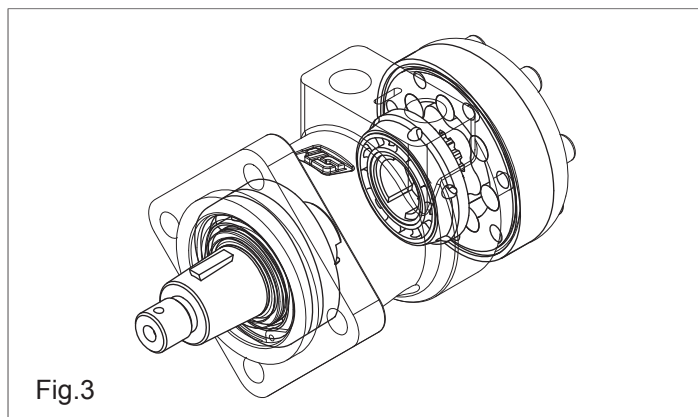

Fig.3

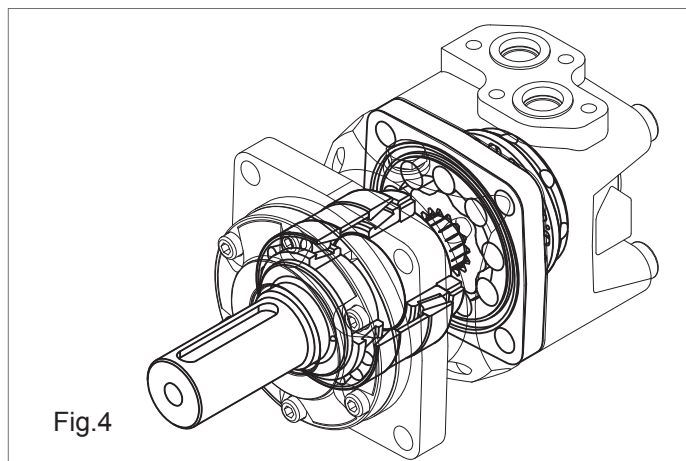

Fig.4

## TIPOLOGIE PRINCIPALI

### **BGM**

Motori gerotor a distribuzione radiale compatti e piccola cilindrata adatti per impieghi ove siano richieste elevate velocità di rotazione ed ingombri ridotti.

### **BG, BH**

Motori gerotor a distribuzione radiale. Caratterizzati da un ottimo rapporto prezzo/prestazioni, sono adatti per impieghi medi e leggeri.

### **BR, BS**

Motori roller a distribuzione radiale caratterizzati da disegno compatto, elevato rendimento, ottima regolarità di rotazione e buona coppia di spunto.

### **ARS**

Motori roller a distribuzione frontale compensata e con supporto dell'albero a cuscinetti. Le versioni ARS con supporto dell'albero a rulli conici hanno una capacità di carico radiale e assiale molto elevata.

### **HR**

Motori con gruppo orbitale a roller quadro, distributore frontale compensato e supporto albero con cuscinetti a rulli conici. Le soluzioni costruttive adottate consentono di raggiungere potenze sino a 44.2 kW.

### **HT**

Motori con gruppo orbitale a roller quadro ad alte prestazioni, valvola di distribuzione compensata con giunto di trascinamento separato e albero di uscita supportato da cuscinetti a rulli conici. Le soluzioni costruttive adottate consentono di raggiungere pressioni di 280 bar e potenze sino a 40 kW. Questi motori sono adatti per tutte quelle applicazioni dove le alte coppie necessarie e l'impiego continuo o con frequenti inversioni del senso di rotazione richiedono motori con elevate caratteristiche.

### **ARSW, HR W**

Motori roller in versione ruota. L'albero di uscita è supportato da cuscinetti a rulli conici ad alta capacità di carico e la flangia è arretrata in modo da ottimizzare la distribuzione del carico. Sono adatti per il montaggio diretto su ruote ed argani.

### **ARF, HR F, HR L**

Motori con freno di stazionamento incorporato. L'albero di uscita supportato da cuscinetti e la presenza del freno di stazionamento incorporato rendono questi motori, dal disegno compatto, adatti alla costruzione di piccole trasmissioni idrostatiche e argani.

## FEATURES OF MAIN TYPES

### **BGM**

Spool valve design and Gerotor gear set hydraulic motor with compact design and small displacement. Suitable for application where high speed and small dimensions are required.

### **BG, BH**

BG series motors feature spool valve design and Gerotor gear set. They are economical motors able to accomplish light to medium duty applications.

### **BR, BS**

The BR series motors feature spool valve and roller gear set design. They feature compact design, high efficiency, smooth rotational and good starting torque.

### **ARS**

Roller gear set hydraulic motors with pressure compensated valve disc and tapered roller bearings support. The ARS series can withstand large radial and axial forces.

### **HR**

Squared stator roller gear set, compensated valve disc featuring separate drive shaft and the tapered roller bearings make the HR series motors suited for application where high power is required. The technical solutions adopted with this model allow to reach an output power up to 44.2 kW [59.2 hp].

### **HT**

Orbital motors with high performance squared stator roller, separately driven and hydraulically compensated disc valve and tapered roller bearings. Working pressure up to 280 bar [4060 psi] and power up to 40 kW [53.6 hp]. These motors are suitable for all those applications where high torque is required and continuous duty or frequent inversions of the sense of rotation make necessary the use of high performance motors.

### **ARSW, HR W**

Hydraulic wheel drive motors with tapered roller bearings and recessed mounting flange. The recessed mounting flange allows to mount a wheel hub or a winch drum so that the radial load acts midway between the two motor bearings. In this way the motor can withstand larger radial and axial forces.

### **ARF, HR F, HR L**

Hydraulic motors with built-in hydraulically released multi-disc static brake. The ball bearings shaft support and the full torque holding brake make this motors a very compact solution for applications like winches and small hydrostatic transmission systems.

### Prestazioni dei motori

La potenza, la velocità e le coppie massime sia continua che intermittenti ottenibili con i vari tipi di motori di produzione Dana Brevini possono essere lette sui seguenti istogrammi (fig. 5).

### Motors performances

The power, speed and torque ratings both for continuous and intermittent duties, of the several motors in the Dana Brevini production range, are available in the following histograms (picture 5).

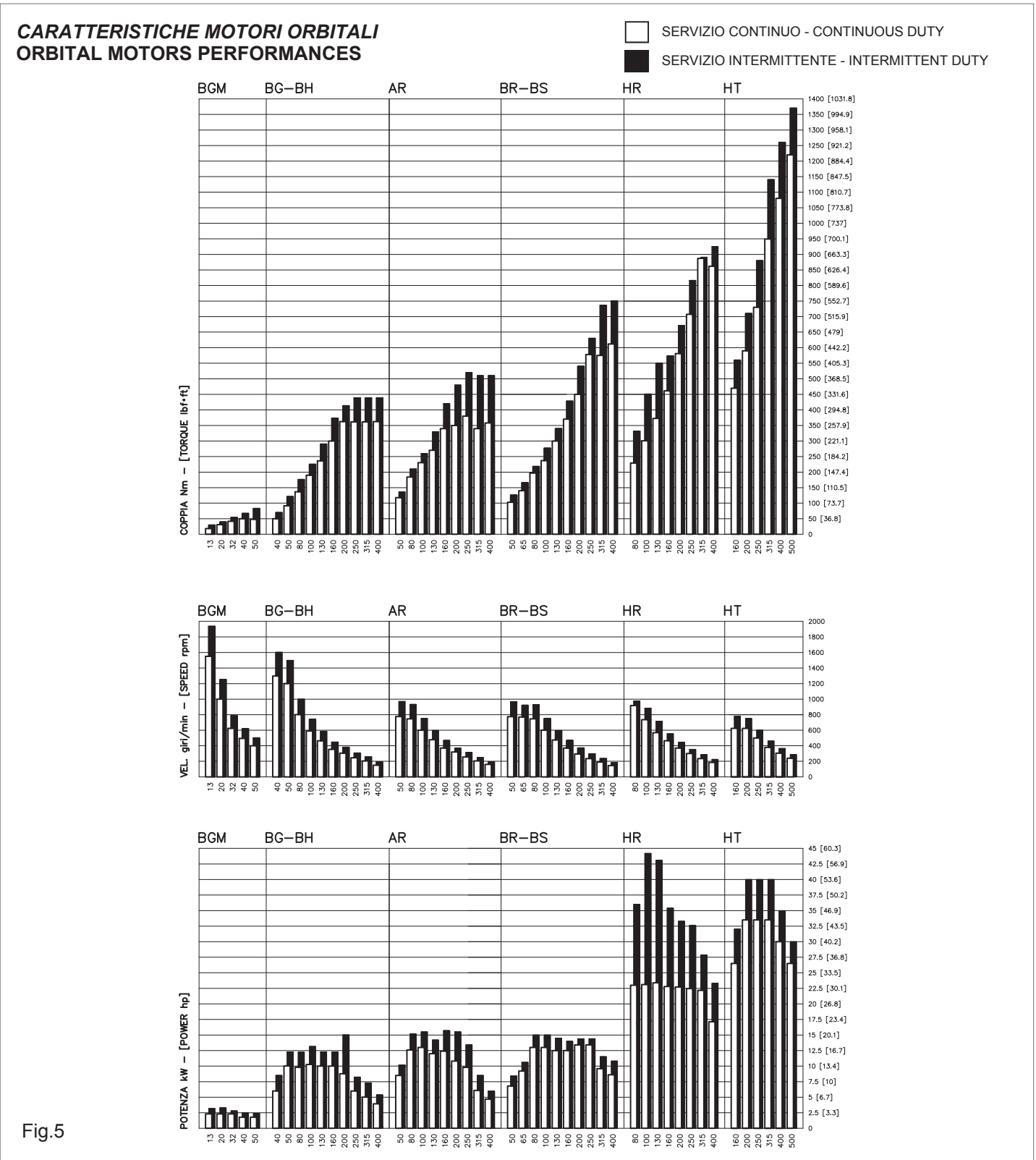

Fig.5

### **Norme generali di manutenzione ed installazione**

- 1) I motori devono essere impiegati entro i valori previsti dai rispettivi cataloghi ed essere montati già pieni di olio soprattutto quelli di cilindrata elevata.
- 2) La temperatura dell'olio in funzionamento deve essere compresa normalmente da +30°C a +60°C, a temperature superiori risulta fortemente ridotta la durata dell'olio.
- 3) La temperatura dell'ambiente in cui è installato il motore deve essere compresa tra -30°C e +90°C.
- 4) Per un corretto funzionamento occorre utilizzare un olio a base minerale contenente additivi antiusura di gradazione ISO 46 o con una viscosità alla normale temperatura di funzionamento di circa 37 cSt e con un indice di viscosità adeguato. In ogni caso la viscosità dell'olio non dovrebbe scendere sotto i 22 cSt o superare i 75 cSt alle temperature di funzionamento. Viscosità minima accettabile per brevi periodi: 10 cst.
- 5) E' possibile utilizzare con i motori Dana Brevini fluidi non infiammabili. Consultare in tal caso il servizio tecnico Dana Brevini.
- 6) Prima di avviare l'impianto occorre verificare che tutti i componenti siano stati correttamente montati e che l'olio nel serbatoio sia al livello previsto.
- 7) E' necessario poi togliere l'aria dall'impianto lasciandolo funzionare 10-15 minuti senza carico per evitare la formazione di schiuma e funzionamento irregolare.
- 8) Lasciare funzionare l'impianto per 30 minuti senza carico collegandolo ad un filtro esterno con elemento da almeno 10µm o con capacità filtrante circa doppia di quella normale dell'impianto.
- 9) Verificate eventuali perdite, si ripristini il livello dell'olio.
- 10) Controllare con regolarità il livello dell'olio e provvedere alla pulizia e sostituzione dei filtri secondo le norme prescritte dalle Case produttrici.

### **Filtraggio dell'olio**

Per assicurare un buon funzionamento ed una lunga durata dei motori Dana Brevini, è necessario che il livello di contaminazione dell'olio sia contenuto entro il valore 22/20/17 secondo la norma ISO 4406:1999, a tal fine è indispensabile che i filtri sul ritorno al serbatoio permettano un livello di filtrazione di 40µm assoluti o 25µm nominali in circuito aperto e 20µm assoluti e 10µm nominali in circuito chiuso.

### **Tenute statiche e dinamiche**

I motori Dana Brevini montano come standard tenute statiche e dinamiche (tenute rotanti) in NBR.

Tali tenute possono offrire ottime garanzie di durata ed efficienza con ogni tipo di olio minerale additivato.

Per l'impiego di altri fluidi si prega di consultare l'organizzazione tecnica della Dana Brevini.

La temperatura dovrà, con le tenute di serie, essere compresa tra i -30°C e +90°C per non compromettere l'efficienza.

### **Il drenaggio**

Quando la pressione sullo scarico del motore supera la massima pressione ammessa sulla tenuta rotante dell'albero (dipendente anche dalla velocità dell'albero) riportata sul catalogo relativo, è indispensabile collegare direttamente al serbatoio il drenaggio del motore con apposita linea.

È consigliabile anche adottare un'ideale linea di drenaggio con i motorifreno (in quanto l'olio drenato contribuisce allo smaltimento del calore generato dal freno), con i motori corti

### **General maintenance and installation rules**

- 1) Motors must be operated not exceeding the working parameters published in the corresponding catalogue. Motors should be filled with oil before operation, particularly for large displacement units.
- 2) Working oil temperatures in the hydraulic system should be kept between + 30°C and + 60°C. The anti-wear and lubrication properties of the oil are greatly reduced at higher temperatures.
- 3) The ambient temperature around the motor should be between -30°C and + 90°C.
- 4) Only use an oil containing antiwear additives ISO 46 or with a viscosity at normal operating temperature of approx. 37 cSt. Fluid should also have an adequate viscosity index. Under no circumstances should oil viscosity be outside the range of 22 cSt to 75 cSt at the above mentioned temperature range. Minimum acceptable viscosity for short periods: 10 cst.
- 5) BDana revini Fluid Power motors can be used with fire resistant fluid. Contact Dana Brevini technical department for advice.
- 6) Before starting the hydraulic system check oil level and correct mounting of all components.
- 7) Run the system unloaded for 10-15 minutes to purge air from the circuit and to prevent foaming and jerky movement.
- 8) Flush the system for 30 minutes, unloaded and connected to an auxiliary filter. This filter should be at least 10µm or finer than the normal circuit filtering capacity.
- 9) Check for leaks, and top up reservoir.
- 10) Check oil level regularly and clean filters or replace them according to filter manufacturers advice.

### **Oil filtering**

For maximum life from Dana Brevini motors oil contamination should never exceed 22/20/17 (see ISO 4406:1999).

To ensure this level, return line filters should have filtering capability of 40µm absolute or 25µm nominal in open circuit, 20µm absolute and 10µm nominal in closed circuit.

### **Static and dynamic seals**

Dana Brevini standard motors have static and dynamic seals (rotating) made of NBR.

These seals offer improved efficiency and prolonged life with all types of mineral oil.

For other fluids or seals material contact Dana Brevini.

Under no circumstances should seals be subjected to temperatures outside the range of - 30°C to + 90°C.

### **Drain line**

When the back pressure of the return line exceeds the maximum acceptable level shown in the corresponding catalogue, it will be necessary to provide a separate drain line connected to the reservoir. A drain line is always recommended for brake motors (as drain oil passing through the motor provides essential cooling), also for short motors (those without output shaft) and in general when it is necessary to reduce the pressure on the shaft seal.



(senza albero d'uscita) ed in generale in tutte le applicazioni e versioni in cui sia necessario contenere la pressione sulla tenuta rotante.

Negli altri casi le valvole di drenaggio interne al motore consentono di operare con una pressione sulla tenuta rotante pari alla pressione sulla linea di scarico.

### Circuiti e collegamenti

I motori Dana Brevini possono essere utilizzati sia in impianti a circuito aperto (fig. 6) che in impianti a circuito chiuso (fig. 7). Inoltre più motori possono essere collegati in serie (fig. 8), in parallelo (fig. 9), oppure è possibile passare dal collegamento in serie a quello in parallelo e viceversa (fig. 10).

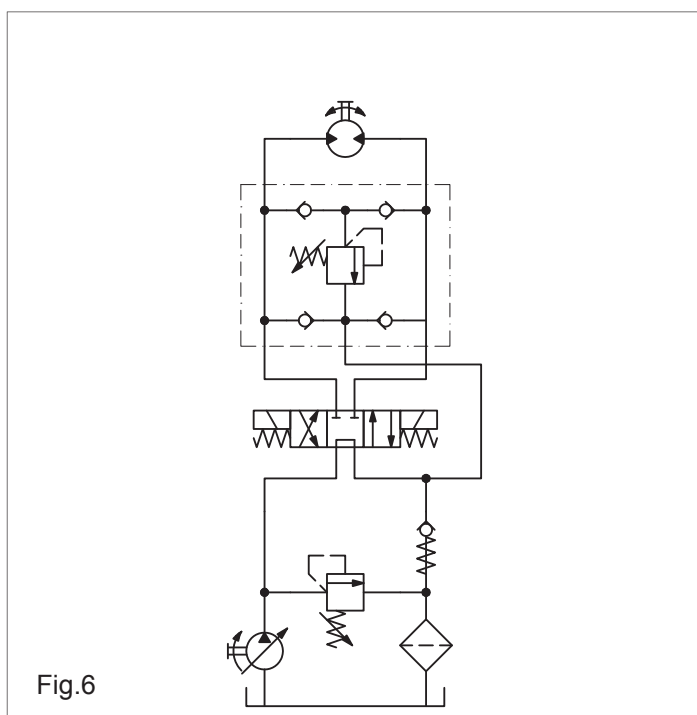

In some models internal check valves ensure the pressure in the motor case never exceeds that of the return line.

### Circuit and connections

Dana Brevini motors can be used in open circuit (fig. 6) as well as closed circuit (fig. 7). They can also be connected in series (fig. 8) or in parallel (fig. 9) or even to switch between series and parallel circuit (fig. 10).

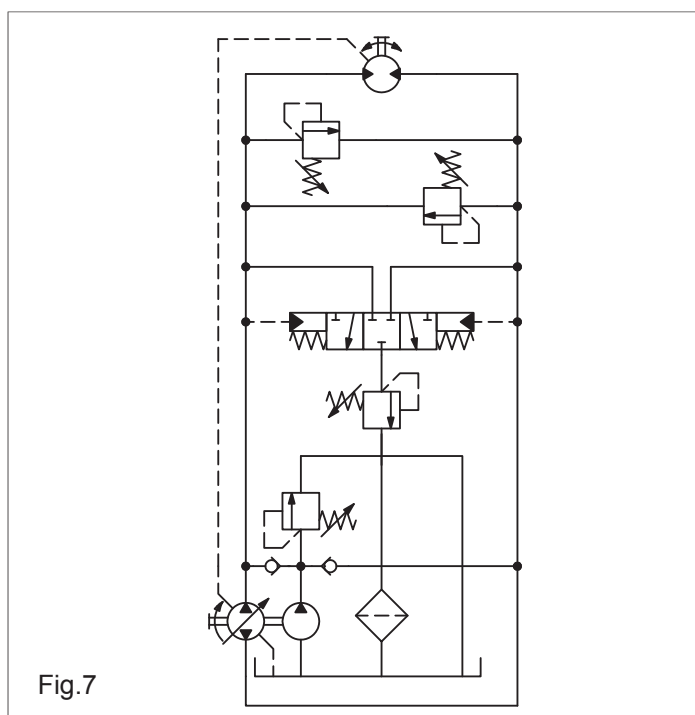

### Collegamento in serie

Nel collegamento in serie (fig. 8) tutta la portata della pompa passa attraverso ogni motore, in tal modo tutti i motori ruotano allo stesso numero di giri (se hanno la stessa cilindrata) od a numeri di giri tra loro proporzionali (se di diversa cilindrata). Occorre però considerare che i trafilamenti sui vari motori (dipendenti dal  $\Delta p$  e quindi dal carico sul singolo motore) comportano una riduzione dei giri effettivi rispetto quelli teorici e quindi una velocità non perfettamente identica per i vari motori, se poi si considera che il drenaggio di un motore comporta (nel caso lo si colleghi ad una linea di drenaggio) una diminuzione della portata di alimentazione dei motori successivi della serie, si può intuire come il numero di giri di ciascun motore della serie non possa essere rigorosamente costante (o proporzionale). I motori Dana Brevini con distribuzione compensata idraulicamente offrono le migliori garanzie di contenimento dei trafilamenti e del drenaggio.

Qualora poi si desideri un'accurata costanza del numero di giri è opportuno rinunciare al drenaggio esterno adottando motori con guarnizioni sull'albero adatte per elevate pressioni.

Il  $\Delta p$  di funzionamento della pompa è nel collegamento in serie pari alla somma dei  $\Delta p$  di ciascun motore (dipendenti dal carico assorbito all'albero).

### Series connection

In series connection (fig. 8) all the oil coming from the pump passes through each motor which therefore turn (theoretically) at the same shaft speed (assuming they have same displacement) or each to a speed proportional to its size (for different displacements).

However, external oil leakage on each motor (depending on  $\Delta p$  due to load variations) will possibly result in a variation in speed compared to the theoretical one: if an external drain line is provided, the leakage flow will reduce the available flow to the following motor.

Therefore, the theoretical speed can not be maintained in the following motor.

Dana Brevini motors with pressure compensated distribution guarantee a smaller drain flow and smaller leakages, therefore reducing the above mentioned problem.

The most precise and constant output speed is achieved using motors with high pressure shaft seals and without the external drain.

In series connection the pump pressure is equal to the sum of the working  $\Delta p$  of all the motors.

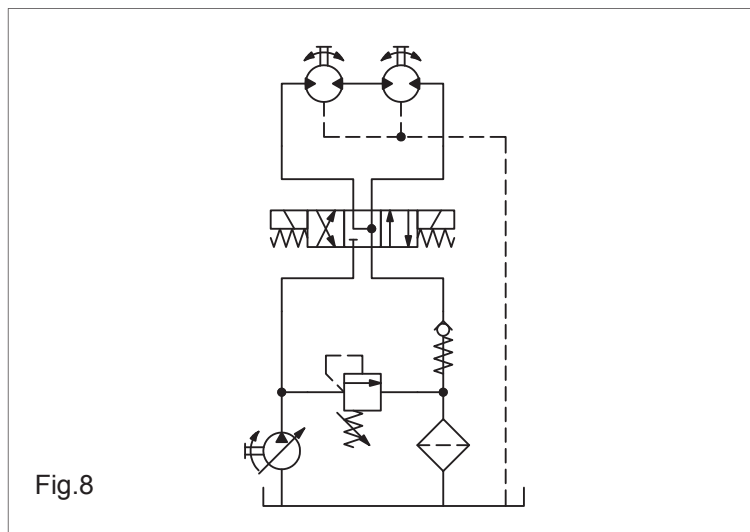

### Collegamento in parallelo

Con motori collegati in parallelo (fig. 9) su ogni motore agisce l'intero  $\Delta p$  disponibile dalla pompa, quindi vengono resi disponibili agli alberi dei vari motori momenti uguali (se di uguale cilindrata) o proporzionali (se di cilindrata diversa). Ad ogni singolo motore verrà distribuita una portata dipendente dalla sua cilindrata e dal carico agente all'albero realizzandosi così con effetto differenziale idraulico utile ad esempio nell'azionamento della traslazione di macchine semoventi.

### Parallel connections

With motors connected in parallel (fig. 9) every motor is subjected to the  $\Delta p$  provided by the pump. Hence motors of same displacement will provide the same torque, or if of different displacement will provide torque proportional to their displacements. In this circuit all motors will require flow under pressure from the pump according to their desired speed. This makes the system work as a "hydraulic differential" and is ideal for traction drive for mobile machinery.

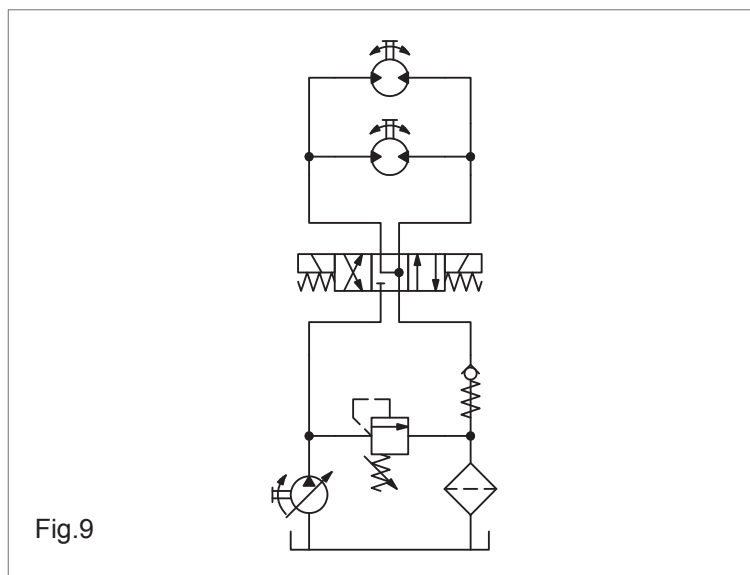

### Collegamento in serie-parallelo

Nel collegamento in serie parallelo (fig. 10) è possibile impiegando un secondo distributore commutare dalla disposizione in serie a quella in parallelo e viceversa realizzando in tal modo un cambio idraulico di velocità. Con la disposizione in serie si ottiene la massima velocità dei motori con coppie limitate e rinunciando all'effetto differenziale (i motori gireranno alla stessa velocità).

Con la disposizione in parallelo si avranno bassa velocità, coppie elevate e l'effetto differenziale.

### Series parallel circuit

With this configuration (fig. 10) by using an additional control valve it is possible to switch between series and parallel circuit, making the system able to perform like a multi speed gearbox.

In series configuration the motors provide maximum speed and low torque, vice versa in parallel. In series circuit the motor will run at the same speed.

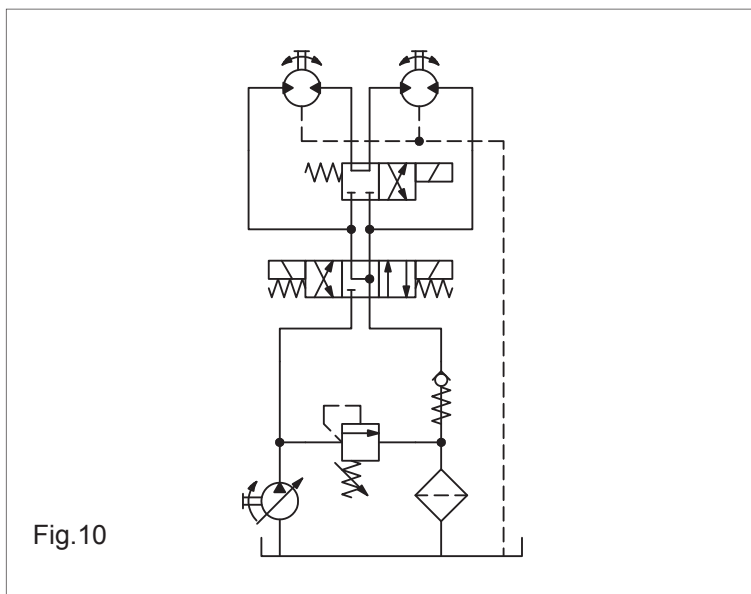

### Utilizzazione dei motori nella frenatura

Per frenare un carico è possibile impiegare un motore Dana Brevini dotando l'impianto di valvole di frenatura opportune. In tale impiego il motore si trasforma in una pompa che converte l'energia meccanica del carico da frenare in energia idraulica del liquido impiegato. Quanto maggiore sarà la cilindrata del motore e più elevata la pressione di apertura delle valvole di frenatura, tanto più energica sarà l'azione frenante.

Calcolo della pressione di apertura della valvola di frenatura.

Tenendo conto dei rendimenti idromeccanici nei funzionamenti come pompa del motore idraulico, si può ritenere che la coppia assorbita durante la frenatura sia data da:

### Use of Sam motors in braking mode

When using Dana Brevini motors it is necessary to use the correct braking valves when dissipating the inertia of the load.

In such circumstance the motor will operate as a pump converting the inertia into hydraulic energy and this energy is then dissipated across the braking valves.

The greater the motors displacement and the higher the pressure setting of the valve, the greater will be the braking torque.

Calculation of the setting pressure of the braking valve:

Considering the total efficiency of the motor while being used as a pump, the absorbed torque during braking action is:

$$M_t = 1.3 \times M_m$$

essendo  $M_t$  la coppia assorbita dal motore durante la frenatura con una certa pressione di apertura della valvola di frenatura; ed  $M_m$  la coppia erogata dal motore (desumibile dal diagramma di funzionamento) alla stessa pressione ed alla velocità media della fase di frenatura.

Per evitare sovraccarichi al motore durante il rallentamento del carico è opportuno regolare l'apertura della valvola al valore massimo di portata al motore.

Si dovrà poi in ogni caso assicurare all'aspirazione del motore durante la frenatura un'alimentazione ed una pressione adeguate per evitare fenomeni di cavitazione e svuotamento del motore con conseguente annullamento della sua capacità frenante.

$M_t$ : torque absorbed by the motor during braking with a given pressure setting of the valve.

$M_m$ : the torque output of the motor (see performance charts) for a given pressure and speed during normal operation.

To avoid overloading the motor during deceleration it is recommended that the flow through the valve is not greater than the maximum flow of the motor in normal operating mode.

During braking it will also be necessary to provide a boosted inlet flow to avoid cavitation.



### Valvole di frenatura consigliate

Per la frenatura dinamica di un carico in movimento (carico sospeso, torretta di una GRU, traslazione di un veicolo, ecc.) si possono, a seconda dell'applicazione particolare, impiegare vari tipi di valvole.

Se non è indispensabile impiegare un freno meccanico a disimpegno idraulico (vedi oltre) si può impiegare semplicemente una valvola antiurto ed anticavitazione (vedi fig. 11). Qualora si intenda utilizzare un freno meccanico si può impiegare una valvola di controllo a doppio bilanciamento con selettore del fluido in pressione (vedi fig. 12). Impiegando quest'ultimo tipo di valvola sarà indispensabile utilizzare un distributore a centro aperto in quanto solo tale tipo di distributore consente di alimentare il motore durante la frenatura, mentre con la valvola precedente si deve impiegare un distributore a centro chiuso in quanto solo così il fluido è costretto ad aprire la valvola provocando il rallentamento del carico.

Con entrambi i tipi di valvola sarà poi indispensabile predisporre una valvola di non ritorno sul ramo di scarico al serbatoio regolata ad una pressione sufficiente per evitare fenomeni di cavitazione nel motore ed il suo svuotamento durante la frenatura.

### Stazionamento del carico

Impiegando un motore idraulico per frenare un carico occorre considerare che è praticamente impossibile, a causa dei trafileamenti nel motore, nelle valvole e nel distributore, garantire un perfetto stazionamento sotto carico del motore.

Mantenendo il carico applicato il motore tenderà, seppur lentamente a cedere. Se ciò non può essere accettato si consiglia l'adozione di un freno meccanico a disimpegno idraulico, solo così sarà garantito un assoluto stazionamento anche con carico applicato, purchè non venga superata la coppia statica massima del freno.

### Recommended braking valves

To control a moving or suspended load it is possible to use a variety of valves.

When no static brake is required, then a simple anti-shock and anti-cavitation valve is recommended (fig. 11).

When using an hydraulically released static brake, a shuttle valve is required to ensure automatic release of the brake (fig. 12). In this case it is necessary to use an open centre directional valve, to ensure that the motor is fed with oil during braking and therefore avoiding cavitation.

When using the anti-shock valve, however, closed centre valves are required as this is the only way to open the pressure valve during braking.

Both types of valve need a check valve on the return line which is set at sufficient pressure to avoid cavitation of the motor.

### Holding a load

It is important to be aware that because of internal motor leakage and other possible circuit leakage it is not possible to ensure hydraulic holding of the load.

Because of the inevitable leakages, the motor will creep when driven by the load. The designer of the application should therefore implement a static brake, hydraulically released, capable of holding the maximum design load.

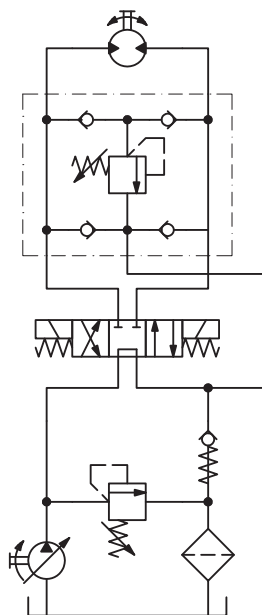

Fig.11

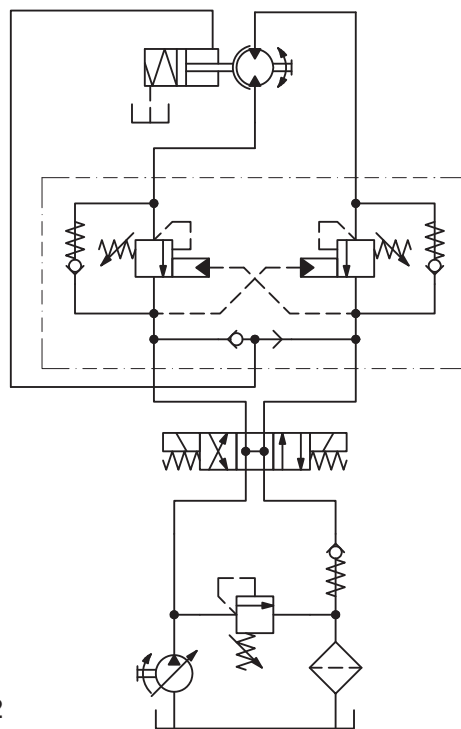

Fig.12

# CALCOLO DELLE GRANDEZZE NOMINALI DI POMPE E MOTORI NOMINAL VALUES CALCULATION FOR MOTORS AND PUMPS

## Pompe: Calcolo delle grandezze nominali / Pumps: Nominal values calculation

<b>Portata generata</b> Output flow	$Q = \frac{V_g \cdot n \cdot \eta_v}{1000}$	(l/min)	$V_g =$ cilindrata geometrica ( $cm^3/giro$ ) / geometrical displacement ( $cm^3/rev$ ) $\Delta p =$ caduta di pressione (bar) / drop of pressure (bar) $n =$ velocità (rpm) / speed (rpm) $Q =$ portata (l/min) / flow (l/min)
<b>Coppia assorbita</b> Drive torque	$M = \frac{\Delta p \cdot V_g}{62.8} \cdot \frac{1}{\eta_{hm}}$	(Nm)	$M =$ coppia (Nm) / torque (Nm) $W =$ potenza (kW) / power (kW) $\eta_v =$ rendimento volumetrico / volumetric efficiency $\eta_{hm} =$ rendimento idromeccanico / mech-hyd. efficiency
<b>Potenza assorbita</b> Driver power	$W = \frac{M \cdot n}{9550} = \frac{Q \cdot \Delta p}{600} \cdot \frac{1}{\eta_t}$	(kW)	$\eta_t =$ rendimento totale ( $\eta_t = \eta_v \cdot \eta_{hm}$ ) / overall efficiency ( $\eta_t = \eta_v \cdot \eta_{hm}$ )

## Motori: Calcolo delle grandezze nominali / Motors: Nominal values calculation

<b>Portata in ingresso</b> Input flow	$Q = \frac{V_g \cdot n}{1000} \cdot \frac{1}{\eta_v}$	(l/min)	
<b>Coppia fornita</b> Output torque	$M = \frac{\Delta p \cdot V_g \cdot \eta_{hm}}{62.8}$	(Nm)	$V_g =$ cilindrata geometrica ( $cm^3/giro$ ) / geometrical displacement ( $cm^3/rev$ ) $\Delta p =$ caduta di pressione (bar) / drop of pressure (bar) $n =$ velocità (rpm) / speed (rpm) $Q =$ portata (l/min) / flow (l/min) $M =$ coppia (Nm) / torque (Nm) $W =$ potenza (kW) / power (kW) $\eta_v =$ rendimento volumetrico / volumetric efficiency $\eta_{hm} =$ rendimento idromeccanico / mech-hyd. efficiency
<b>Potenza fornita</b> Output power	$W = \frac{M \cdot n}{9550} = \frac{Q \cdot \Delta p \cdot \eta_t}{600}$	(kW)	$\eta_t =$ rendimento totale ( $\eta_t = \eta_v \cdot \eta_{hm}$ ) / overall efficiency ( $\eta_t = \eta_v \cdot \eta_{hm}$ )
<b>Velocità albero</b> Output speed	$n = \frac{Q \cdot 1000 \cdot \eta_v}{V_g}$	(rpm)	

## FATTORI DI CONVERSIONE CONVERSION FACTORS

La tabella seguente riporta i fattori di conversione tra il sistema di misura metrico ed il sistema inglese per le principali grandezze utilizzate in oleodinamica.

The following table report the conversion factor from metric units of measure to english units for the main units used in hydraulic.

	per convertire to convert		moltiplicare per multiply by	per convertire to convert		moltiplicare per multiply by
	da / from	a / to		da / from	a / to	
lunghezza / length	mm	in	0.039	in	mm	25.4
volume / capacity	l	gal	0.219	gal	l	4.546
massa / mass	kg	lb	2.204	lb	kg	0.4536
forza / force	N	lbf	0.225	lbf	N	4.45
coppia / torque	N·m	lbf·ft	0.737	lbf·ft	N·m	1.357
pressione / pressure	bar	psi	14.5	psi	bar	0.06895
portata / flow	l/min	U.S. gpm	0.264	U.S. gpm	l/min	3.79
potenza / power	kW	hp	1.34	hp	kW	0.746
regime di rotazione / rotation speed	giri/min	r.p.m.	1	r.p.m.	giri/min	1
cilindrata / displacement	cm <sup>3</sup> /giro	in <sup>3</sup> /rev	0.061	in <sup>3</sup> /rev	cm <sup>3</sup> /giro	16.387
temperatura / temperature	°C	°F	1.8x°C+32	°F	°C	(°F-32)/1.8

# IDENTIFICAZIONE DEL PRODOTTO PRODUCT IDENTIFICATION

## Targhetta di identificazione

I prodotti Dana Brevini, linea ORBITALI, sono provvisti di targhetta di identificazione. L'identificazione del prodotto avviene attraverso la matricola. Ogni richiesta d'informazione deve indicare tale numero.

## Name plate

Each Dana Brevini ORBITAL products are supplied with an identification plate. The identification of the product is made through the serial number. Every request of information must quote this number.

### VECCHIA SOLUZIONE OLD SOLUTION

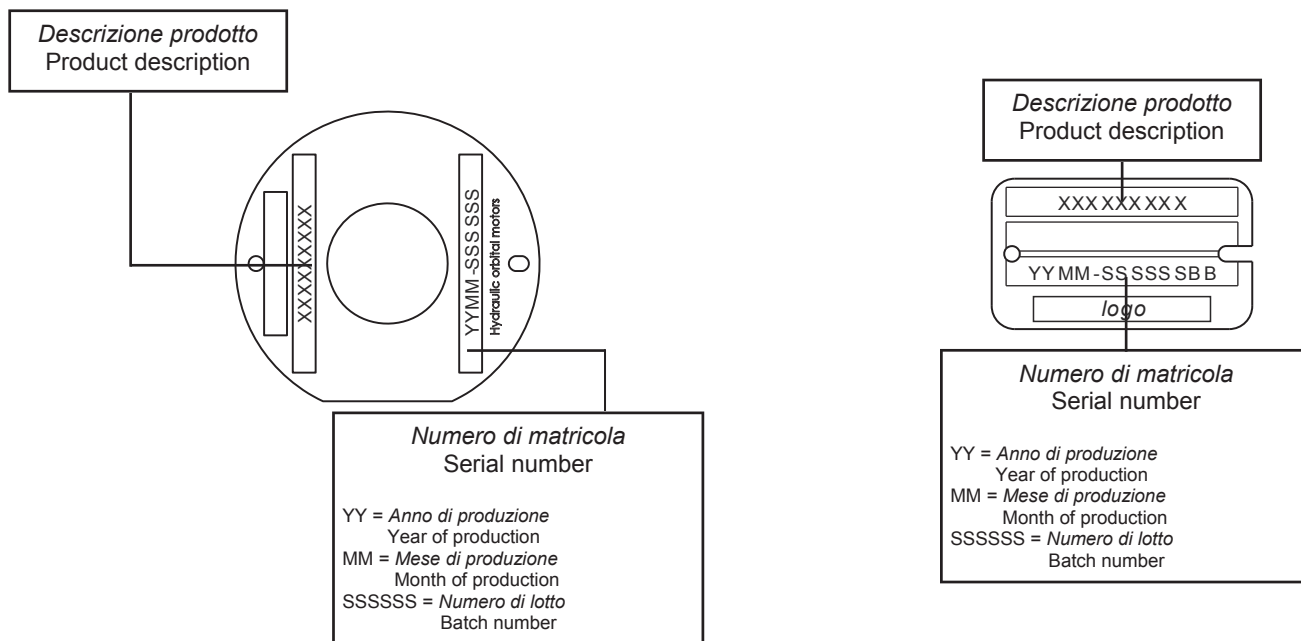

### NUOVA SOLUZIONE NEW SOLUTION

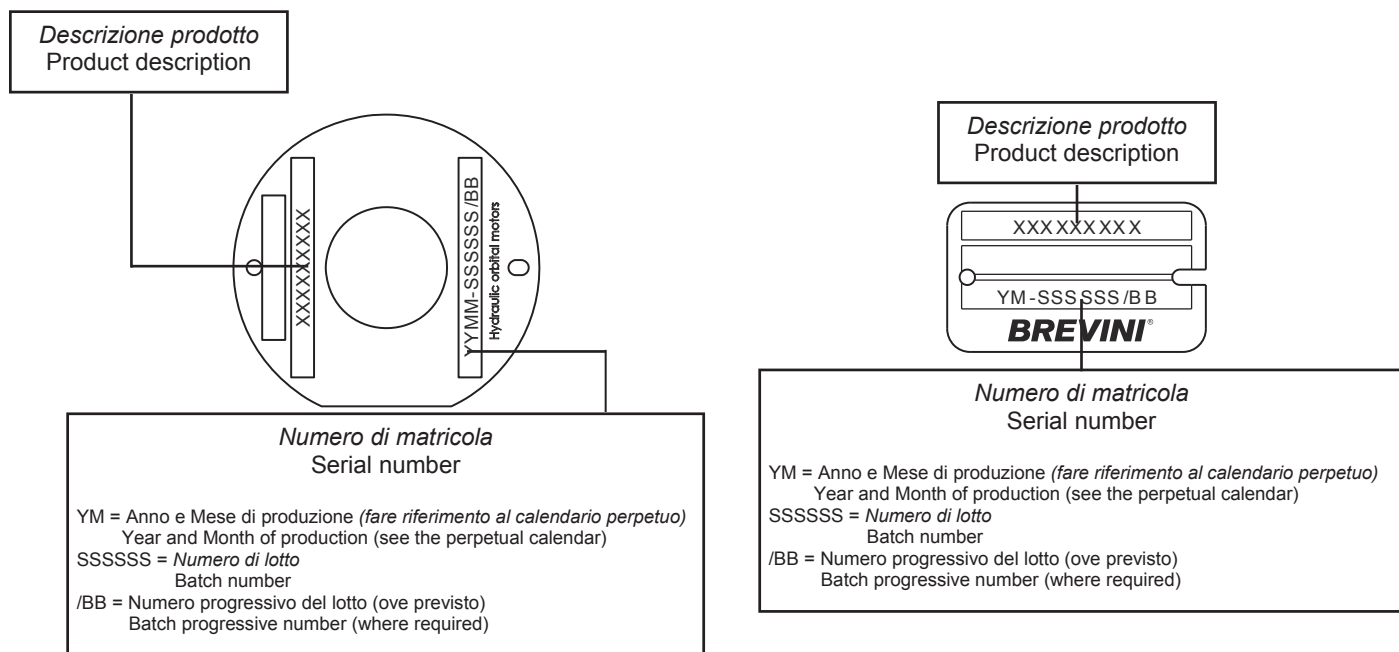

**CALENDARIO PERPETUO "DATARIO PRODUZIONE"  
PERPETUAL CALENDAR "MANUFACTURING DATE"**

	<b>Gennaio</b> <i>January</i>	<b>Febbraio</b> <i>February</i>	<b>Marzo</b> <i>March</i>	<b>Aprile</b> <i>April</i>	<b>Maggio</b> <i>May</i>	<b>Giugno</b> <i>June</i>	<b>Luglio</b> <i>July</i>	<b>Agosto</b> <i>August</i>	<b>Settembre</b> <i>September</i>	<b>Ottobre</b> <i>October</i>	<b>Novembre</b> <i>November</i>	<b>Dicembre</b> <i>December</i>
<b>2000</b>	TN	TP	TQ	TR	TS	TT	TU	TV	TW	TX	TY	TZ
<b>2001</b>	AA	AB	AC	AD	AE	AF	AG	AH	AJ	AK	AL	AM
<b>2002</b>	BA	BB	BC	BD	BE	BF	BG	BH	BJ	BK	BL	BM
<b>2003</b>	CA	CB	CC	CD	CE	CF	CG	CH	CJ	CK	CL	CM
<b>2004</b>	DA	DB	DC	DD	DE	DF	DG	DH	DJ	DK	DL	DM
<b>2005</b>	EA	EB	EC	ED	EE	EF	EG	EH	EJ	EK	EL	EM
<b>2006</b>	FA	FB	FC	FD	FE	FF	FG	FH	FJ	FK	FL	FM
<b>2007</b>	GA	GB	GC	GD	GE	GF	GG	GH	GJ	GK	GL	GM
<b>2008</b>	HA	HB	HC	HD	HE	HF	HG	HH	HJ	HK	HL	HM
<b>2009</b>	JA	JB	JC	JD	JE	JF	JG	JH	JJ	JK	JL	JM
<b>2010</b>	KA	KB	KC	KD	KE	KF	KG	KH	KJ	KK	KL	KM
<b>2011</b>	LA	LB	LC	LD	LE	LF	LG	LH	LJ	LK	LL	LM
<b>2012</b>	MA	MB	MC	MD	ME	MF	MG	MH	MJ	MK	ML	MM
<b>2013</b>	NA	NB	NC	ND	NE	NF	NG	NH	NJ	NK	NL	NM
<b>2014</b>	PA	PB	PC	PD	PE	PF	PG	PH	PJ	PK	PL	PM
<b>2015</b>	QA	QB	QC	QD	QE	QF	QG	QH	QJ	QK	QL	QM
<b>2016</b>	RA	RB	RC	RD	RE	RF	RG	RH	RJ	RK	RL	RM
<b>2017</b>	SA	SB	SC	SD	SE	SF	SG	SH	SJ	SK	SL	SM
<b>2018</b>	TA	TB	TC	TD	TE	TF	TG	TH	TJ	TK	TL	TM
<b>2019</b>	UA	UB	UC	UD	UE	UF	UG	UH	UJ	UK	UL	UM
<b>2020</b>	VA	VB	VC	VD	VE	VF	VG	VH	VJ	VK	VL	VM



**BREVINI<sup>®</sup>**

*Motion Systems*

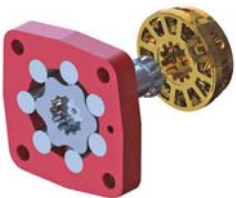
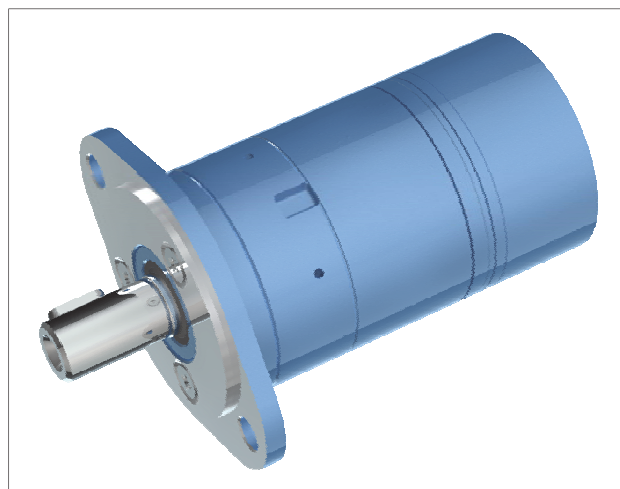

**BGM**

***MOTORI ORBITALI***

**ORBITAL MOTORS**

# CARATTERISTICHE DEL MOTORE MOTOR FEATURES

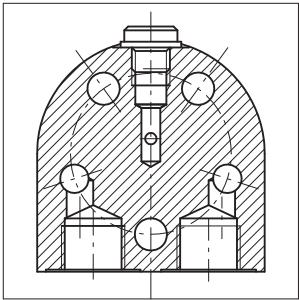
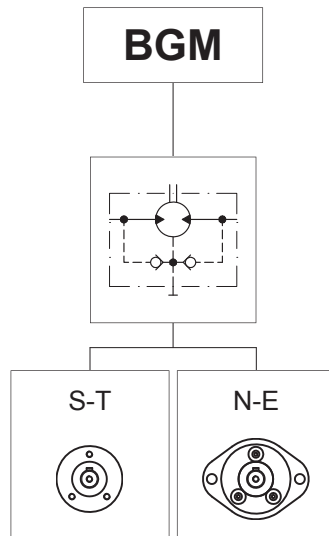

*Alimentazione laterale.*  
Side ports configuration.

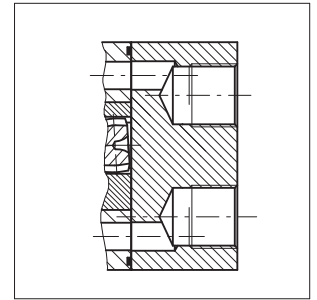

*Alimentazione posteriore.*  
Rear ports configuration.

*Buone capacità di carico radiale e assiale.*  
Very good side and axial load capacity.

*Possibilità di alimentazione laterale o posteriore.*  
Rear and side ports option.

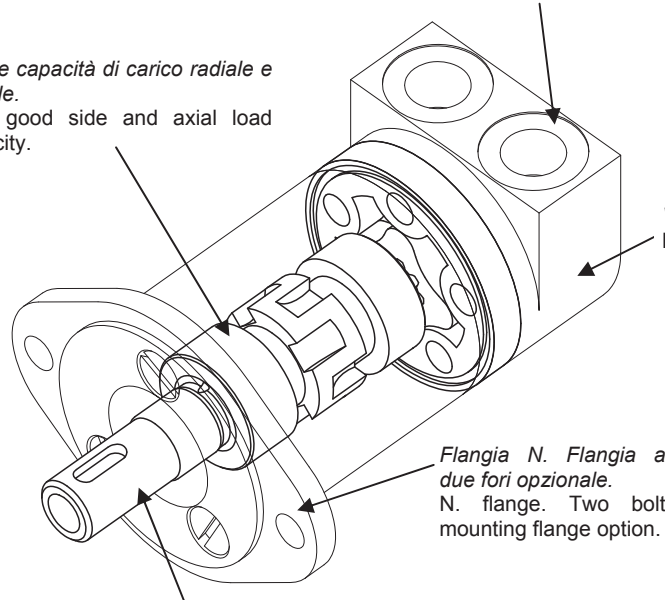

*Valvole interne di drenaggio.*  
Built-in check valves.

*Flangia N. Flangia a due fori opzionale.*  
N. flange. Two bolt mounting flange option.

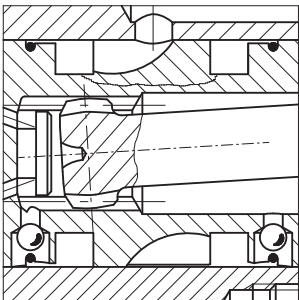

*Distribuzione radiale e tolleranze ridotte al minimo per assicurare un drenaggio ridotto - Valvole interne di drenaggio.*  
Optimized spool valve design to minimize the leakage - built-in check valves.

*Elevato rapporto coppia/peso e buona regolarità a basso numero di giri.*  
High torque/weight ratio and very good low speed performance.

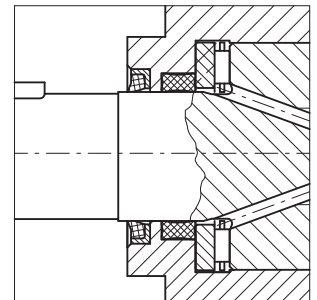

*Parapolvere per proteggere la guarnizione di tenuta dell'albero dalle impurità.*  
Dust seal to protect the high pressure shaft seal.

# CARATTERISTICHE TECNICHE TECHNICAL SPECIFICATIONS

Motore Motor	Cilindrata Displacement cm <sup>3</sup> /giro [in <sup>3</sup> /rev]	Max. pressione in ingresso Max. input pressure bar [psi]		Pressione diff. max. Max. differential pressure bar [psi]		Coppia max.* Max. torque*		Portata max. Max. flow		Velocità max. Max. speed		Potenza max. Max. power	
		Cont Int <sup>1)</sup> Peak <sup>2)</sup>	140 [2030] 175 [2537] 225 [3265]	Cont Int <sup>1)</sup> Peak <sup>2)</sup>	100 [1450] 140 [2030] 200 [2900]	Cont Int <sup>1)</sup> Peak <sup>2)</sup>	16 [11.7] 23 [16.9] 33 [24.3]	Cont Int <sup>1)</sup>	20 [5.28] 25 [6.60]	Cont Int <sup>1)</sup>	1550 1935	Cont Int <sup>1)</sup>	2.3 [3.08] 3.2 [4.28]
BGM 013	12.9 [0.78]	Cont Int <sup>1)</sup> Peak <sup>2)</sup>	140 [2030] 175 [2537] 225 [3265]	Cont Int <sup>1)</sup> Peak <sup>2)</sup>	100 [1450] 140 [2030] 200 [2900]	Cont Int <sup>1)</sup> Peak <sup>2)</sup>	16 [11.7] 23 [16.9] 33 [24.3]	Cont Int <sup>1)</sup>	20 [5.28] 25 [6.60]	Cont Int <sup>1)</sup>	1550 1935	Cont Int <sup>1)</sup>	2.3 [3.08] 3.2 [4.28]
BGM 020	20 [1.22]	Cont Int <sup>1)</sup> Peak <sup>2)</sup>	140 [2030] 175 [2537] 225 [3265]	Cont Int <sup>1)</sup> Peak <sup>2)</sup>	100 [1450] 140 [2030] 200 [2900]	Cont Int <sup>1)</sup> Peak <sup>2)</sup>	25 [18.4] 35 [25.7] 51 [37.5]	Cont Int <sup>1)</sup>	20 [5.28] 25 [6.60]	Cont Int <sup>1)</sup>	1000 1250	Cont Int <sup>1)</sup>	2.3 [3.08] 3.3 [4.42]
BGM 032	31.8 [1.93]	Cont Int <sup>1)</sup> Peak <sup>2)</sup>	140 [2030] 175 [2537] 225 [3265]	Cont Int <sup>1)</sup> Peak <sup>2)</sup>	100 [1450] 140 [2030] 160 [2320]	Cont Int <sup>1)</sup> Peak <sup>2)</sup>	39 [28.7] 54 [39.7] 60 [44.2]	Cont Int <sup>1)</sup>	20 [5.28] 25 [6.60]	Cont Int <sup>1)</sup>	625 785	Cont Int <sup>1)</sup>	2.3 [3.08] 2.8 [3.75]
BGM 040	40.1 [2.44]	Cont Int <sup>1)</sup> Peak <sup>2)</sup>	140 [2030] 175 [2537] 225 [3265]	Cont Int <sup>1)</sup> Peak <sup>2)</sup>	100 [1450] 140 [2030] 160 [2320]	Cont Int <sup>1)</sup> Peak <sup>2)</sup>	50 [36.8] 67 [49.3] 76 [56.0]	Cont Int <sup>1)</sup>	20 [5.28] 25 [6.60]	Cont Int <sup>1)</sup>	495 620	Cont Int <sup>1)</sup>	1.8 [2.41] 2.5 [3.35]
BGM 050	50 [3.05]	Cont Int <sup>1)</sup> Peak <sup>2)</sup>	140 [2030] 175 [2537] 225 [3265]	Cont Int <sup>1)</sup> Peak <sup>2)</sup>	80 [1160] 140 [2030] 160 [2320]	Cont Int <sup>1)</sup> Peak <sup>2)</sup>	49 [36.1] 83 [61.1] 94 [69.2]	Cont Int <sup>1)</sup>	20 [5.28] 25 [6.60]	Cont Int <sup>1)</sup>	400 500	Cont Int <sup>1)</sup>	1.8 [2.41] 2.4 [3.21]

<sup>1)</sup> Le condizioni intermittenti non devono durare più del 10% di ogni minuto / Intermittent duty must not exceed 10% each minute.

<sup>2)</sup> Le condizioni di picco non devono durare più del 1% di ogni minuto / Peak duty must not exceed 1% each minute.

Motore Motor	Pressione max scar. con drenaggio Max return pressure with drain line bar [psi]		Pressione max avviamento a vuoto Max starting pressure with no load bar [psi]		Coppia minima di spunto Min starting torque Nm [lbf-ft]	
	Cont Int <sup>1)</sup> Peak <sup>2)</sup>	140 [2030] 175 [2537] 225 [3265]	Cont Int <sup>1)</sup> Peak <sup>2)</sup>	4 [58] 4 [58] 4 [58]	Cont Int <sup>1)</sup>	12 [8.8] 17 [12.5] 21 [15.4] 30 [22.1] 35 [25.7] 51 [37.5] 34 [25] 48 [35.3] 40 [29.4] 70 [51.5]
BGM 013	Cont Int <sup>1)</sup> Peak <sup>2)</sup>	140 [2030] 175 [2537] 225 [3265]	Cont Int <sup>1)</sup> Peak <sup>2)</sup>	4 [58] 4 [58] 4 [58]	Cont Int <sup>1)</sup>	12 [8.8] 17 [12.5]
BGM 020	Cont Int <sup>1)</sup> Peak <sup>2)</sup>	140 [2030] 175 [2537] 225 [3265]	Cont Int <sup>1)</sup> Peak <sup>2)</sup>	4 [58] 4 [58] 4 [58]	Cont Int <sup>1)</sup>	21 [15.4] 30 [22.1]
BGM 032	Cont Int <sup>1)</sup> Peak <sup>2)</sup>	140 [2030] 175 [2537] 225 [3265]	Cont Int <sup>1)</sup> Peak <sup>2)</sup>	4 [58] 4 [58] 4 [58]	Cont Int <sup>1)</sup>	35 [25.7] 51 [37.5]
BGM 040	Cont Int <sup>1)</sup> Peak <sup>2)</sup>	140 [2030] 175 [2537] 225 [3265]	Cont Int <sup>1)</sup> Peak <sup>2)</sup>	4 [58] 4 [58] 4 [58]	Cont Int <sup>1)</sup>	34 [25] 48 [35.3]
BGM 050	Cont Int <sup>1)</sup> Peak <sup>2)</sup>	140 [2030] 175 [2537] 225 [3265]	Cont Int <sup>1)</sup> Peak <sup>2)</sup>	4 [58] 4 [58] 4 [58]	Cont Int <sup>1)</sup>	40 [29.4] 70 [51.5]

## MASSIMA PRESSIONE AMMESSA SULLA GUARNIZIONE ALBERO MAX PERMISSIBLE SHAFT SEAL PRESSURE

Pressione massima di scarico senza drenaggio o massima pressione nella linea di drenaggio. I motori sono forniti nella versione con guarnizioni standard (diagramma Standard) o nella versione con guarnizioni ad alta pressione (diagramma HPS). Per condizioni di pressione e velocità non contemplate dal presente grafico si consiglia di contattare Dana Brevini.

Max. return pressure without drain line or max. pressure in the drain line. Motor are supplied in standard seal version (Standard chart) or in HPS seal version (HPS chart). For pressure and speeds not showed in the curve below, please contact Dana Brevini.

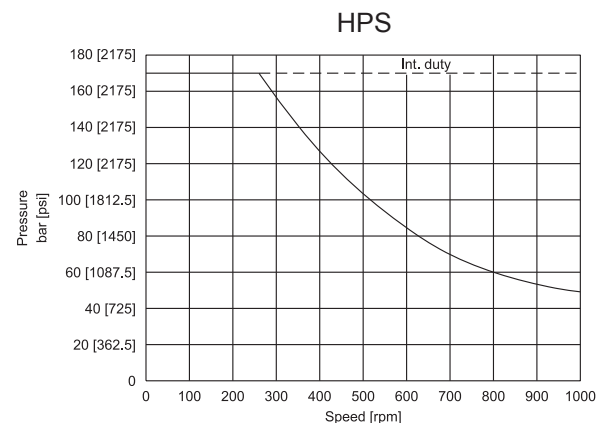
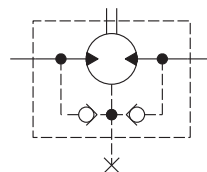
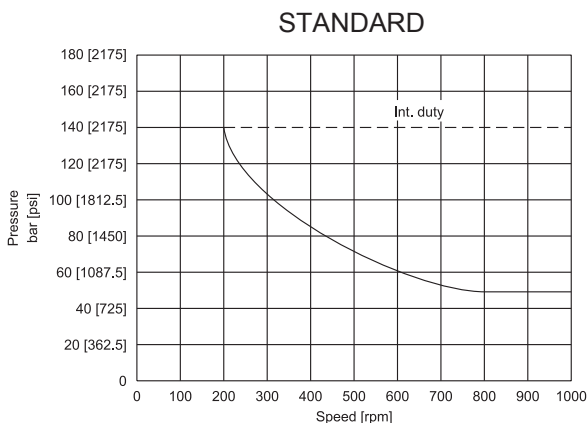

# PERDITE DI CARICO PER ATTRAVERSAMENTO PRESSURE LOSS

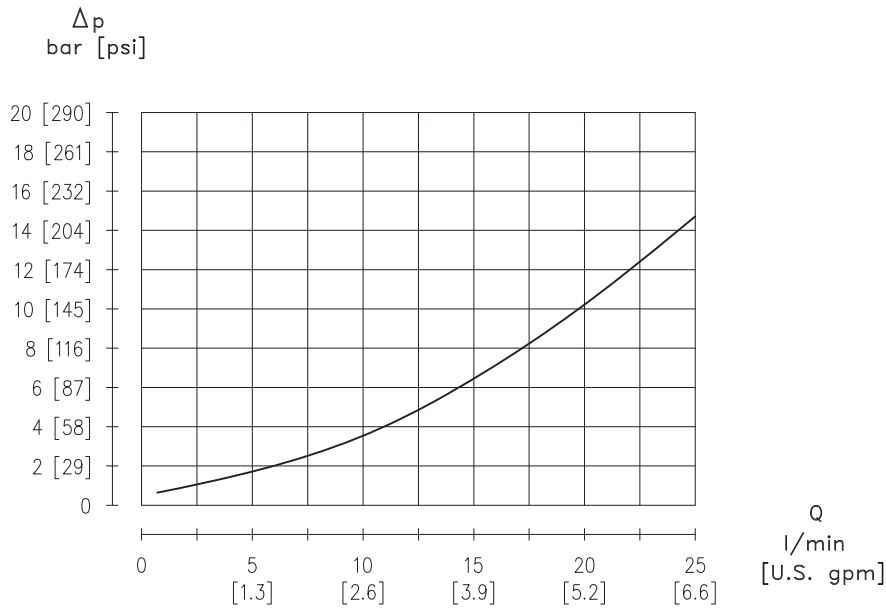

*Il diagramma è stato ottenuto con prove eseguite su un numero significativo di motori, utilizzando un'olio avente una viscosità cinematica di 37 cSt alla temperatura di 45° C.*

Diagram according to tests done with a relevant number of motors and using hydraulic oil with kinematic viscosity of 37 cSt at 45° C temperature.



# CODICE DI ORDINAZIONE ORDERING CODE

Le seguenti lettere o numeri del codice, sono state sviluppate per identificare tutte le configurazioni possibili dei motori BGM. Usare il seguente modulo per identificare le caratteristiche desiderate. **Tutte le lettere o numeri del codice devono comparire in fase d'ordine.** Si consiglia di leggere attentamente il catalogo prima di iniziare la compilazione del codice di ordinazione.

The following alphanumeric digits system has been developed to identify all of the configuration options for the BGM motors. Use the model code below to specify the desired features. **All alphanumeric digits system of the code must be present when ordering.** We recommend to carefully read the catalogue before filling the ordering code.

## CODICE PRODOTTO / MODEL CODE

<b>1</b>	<b>2</b>	<b>3</b>	<b>4</b>	<b>5</b>	<b>6</b>	<b>7</b>	<b>8</b>	<b>9</b>	<b>10</b>	<b>11</b>	<b>12</b>

### 1 - SERIE / SERIES

<b>BGM</b>	Motore orbitale Orbital motor
------------	----------------------------------

### 2 - CILINDRATA / DISPLACEMENT

<b>013</b>	13 cm <sup>3</sup> /giro [0.793 in <sup>3</sup> /rev]
<b>020</b>	20 cm <sup>3</sup> /giro [1.22 in <sup>3</sup> /rev]
<b>032</b>	32 cm <sup>3</sup> /giro [1.952 in <sup>3</sup> /rev]
<b>040</b>	40 cm <sup>3</sup> /giro [2.44 in <sup>3</sup> /rev]
<b>050</b>	50 cm <sup>3</sup> /giro [3.05 in <sup>3</sup> /rev]

### 3 - VERSIONE / VERSION

<b>FR0</b>	Versione Base Standard Version
<b>SP1</b>	Versione SP1 SP1 Version
<b>FRQ</b>	Versione Q Q Version

### 4 - FLANGIA / MOUNT FLANGE

<b>S</b>	3 fori M6 - Ø31.5mm 3 bolts M6 - Ø31.5mm [Ø 1.240 in]	<b>STANDARD</b>
<b>T</b>	3 fori 1/4 - 28 UNF - Ø31.5mm 3 bolts 1/4 - 28 UNF - Ø31.5mm [Ø 1.240 in]	
<b>N</b>	2 fori - Ø63mm (In abbinamento con flangia S) 2 bolts - Ø63mm [Ø 2.480 in] - (combination with S flange)	
<b>E</b>	2 fori - Ø63mm - (In abbinamento con flangia T) 2 bolts - Ø63mm [Ø 2.480 in] - (combination with T flange)	

### 5 - ESTREMITÀ ALBERO / SHAFT END

<b>CL160</b>	Cilindrico Ø16 mm Parallel keyed Ø16 mm [0.629 in]
<b>SC160</b>	Scanalato profilo B17x14 DIN5482 B17x14 DIN5482 Splined
<b>CL158</b>	Cilindrico Ø15.88 mm Parallel keyed Ø15.88 mm [Ø0.625 in]
<b>CS158</b>	Cilindrico crosshole Ø15.88 mm Parallel crosshole Ø15.88 mm [Ø0.625 in]

1	2	3	4	5	6	7	8	9	10	11	12
---	---	---	---	---	---	---	---	---	----	----	----

#### 6 - ATTACCO / MAIN PORT

		VERSIONE / VERSION		
		FR0	SP1	FRQ
M06	Attacchi 3/8 G (BSPP) 3/8 G (BSPP) Main Ports	STANDARD	•	•
S06	Attacchi 9/16 - 18 UNF 9/16 - 18 UNF Main Ports		•	/

• Disponibile - Available / Non Disponibile - Not Available

#### 7 - TENUTA / SEAL

N	NBR
---	-----

#### 8 - VALVOLA / VALVE

		ATTACCO / MAIN PORT	
		M06	S06
XXXX	Non Richieste Not Required	•	•
M061	Valvola di massima pressione VAF 06 - D Pressure relief valve VAF 06 - D	•	/

• Disponibile - Available / Non Disponibile - Not Available

#### 9 - CARATTERISTICA VALVOLA / VALVE FEATURE

		VALVOLA / VALVE	
		XXXX	M061
000	Caratteristica non necessaria Feature not necessary	•	/
030	Non Tarata (Campo Taratura 50+150 bar) Not Set 50+150 bar [725 to 2175 psi]	/	•

• Disponibile - Available / Non Disponibile - Not Available

#### 10 - OPZIONE / OPTION

XX	Nessuna Opzione None
----	-------------------------

#### 11 - CARATTERISTICA VERSIONE / VERSION FEATURE

		FLANGIA / FLANGE			
		S	T	N	E
QDG	Versione QUAD-RING con Drenaggio posteriore 1/8 G (BSPP) QUAD-RING version with Rear drain 1/8 G (BSPP)	•	•	•	•
HPS	Guarnizione alta pressione High Pressure Seal	•	•	•	•
TES	Tachimetro TAC-E (con predisposizione per sensore) - Senso di rotazione impiego SX (Standard) TAC-E Tachometer (with sensor arrangement) - CCW suitable direction of rotation (Standard)	•	/	•	/
TED	Tachimetro TAC-E (con predisposizione per sensore) - Senso di rotazione impiego DX (Opzionale) TAC-E Tachometer (with sensor arrangement) - CW suitable direction of rotation (Optional)	•	/	•	/

• Disponibile - Available / Non Disponibile - Not Available

#### 12 - VERNICIATURA / PAINTING

XX	Non Verniciato Not Painted
01	Verniciato Nero RAL 9005 Black Painted RAL 9005
22	Verniciato Grigio RAL 7035 Grey Painted RAL 7035

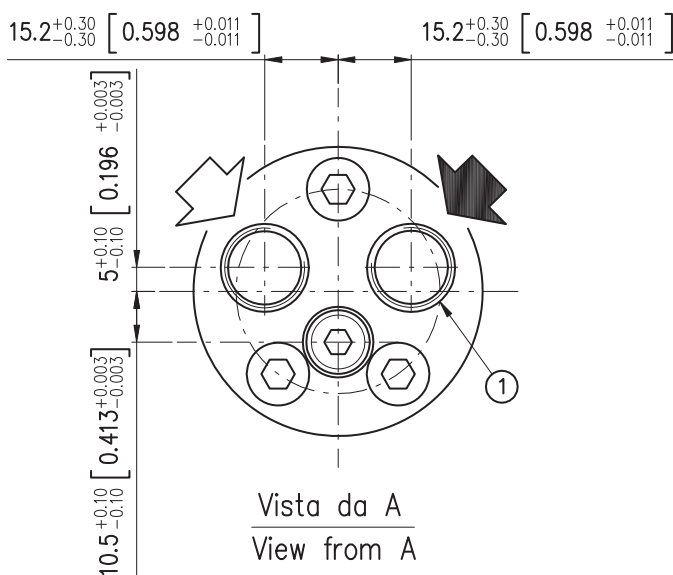
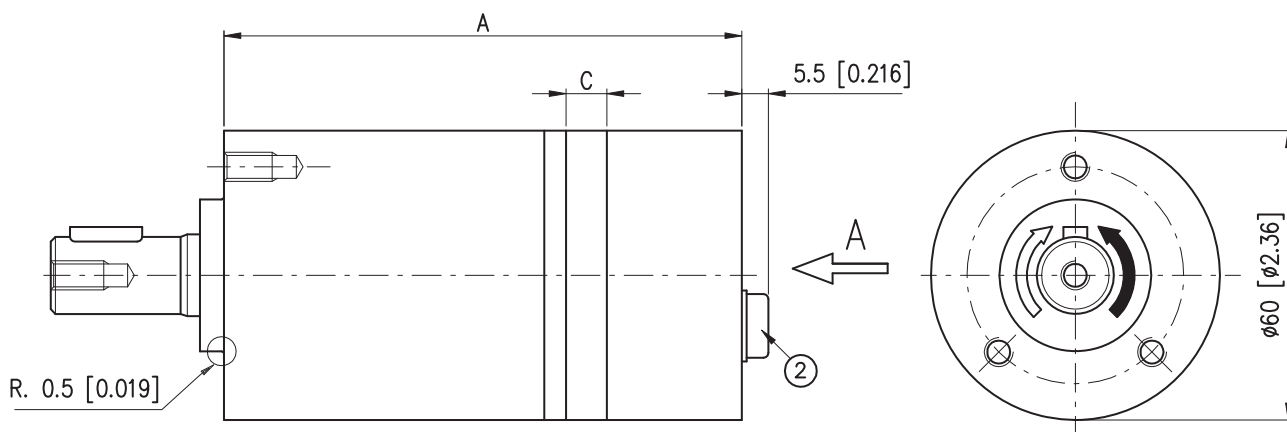

**ATTACCHI M06 / M06 MAIN PORTS**

- 1) N.2 Fori di alimentazione 3/8 G (BSPP) prof. filetto 12mm  
N.2 3/8 G (BSPP) main ports thread depth [0.472 in]
- 2) Drenaggio motore 1/8 G (BSPP) prof. filetto 9mm  
1/8 G (BSPP) drain port thread depth [0.354 in]

**ATTACCHI S06 / S06 MAIN PORTS**

- 1) N.2 Fori di alimentazione 9/16"-18 UNF prof. filetto 13mm  
N.2 9/16"-18 UNF main ports thread depth [0.511 in]
- 2) Drenaggio motore 7/16"-20 UNF prof. filetto 12mm  
7/16"-20 UNF drain port thread depth [0.472 in]

		BGM 013	BGM 020	BGM 032	BGM 040	BGM 050
<b>A</b>	<b>mm [in]</b>	104.5 [4.11]	107.5 [4.23]	112.5 [4.42]	116 [4.56]	120 [4.72]
<b>B</b>	<b>mm [in]</b>	-	-	-	-	-
<b>C</b>	<b>mm [in]</b>	5.5 [0.216]	8.5 [0.334]	13.5 [0.531]	17 [0.66]	21 [0.82]
<b>Pesi - Weight</b>	<b>kg [lb]</b>	2 [4.4]	2.06 [4.5]	2.15 [4.7]	2.2 [4.8]	2.25 [4.9]

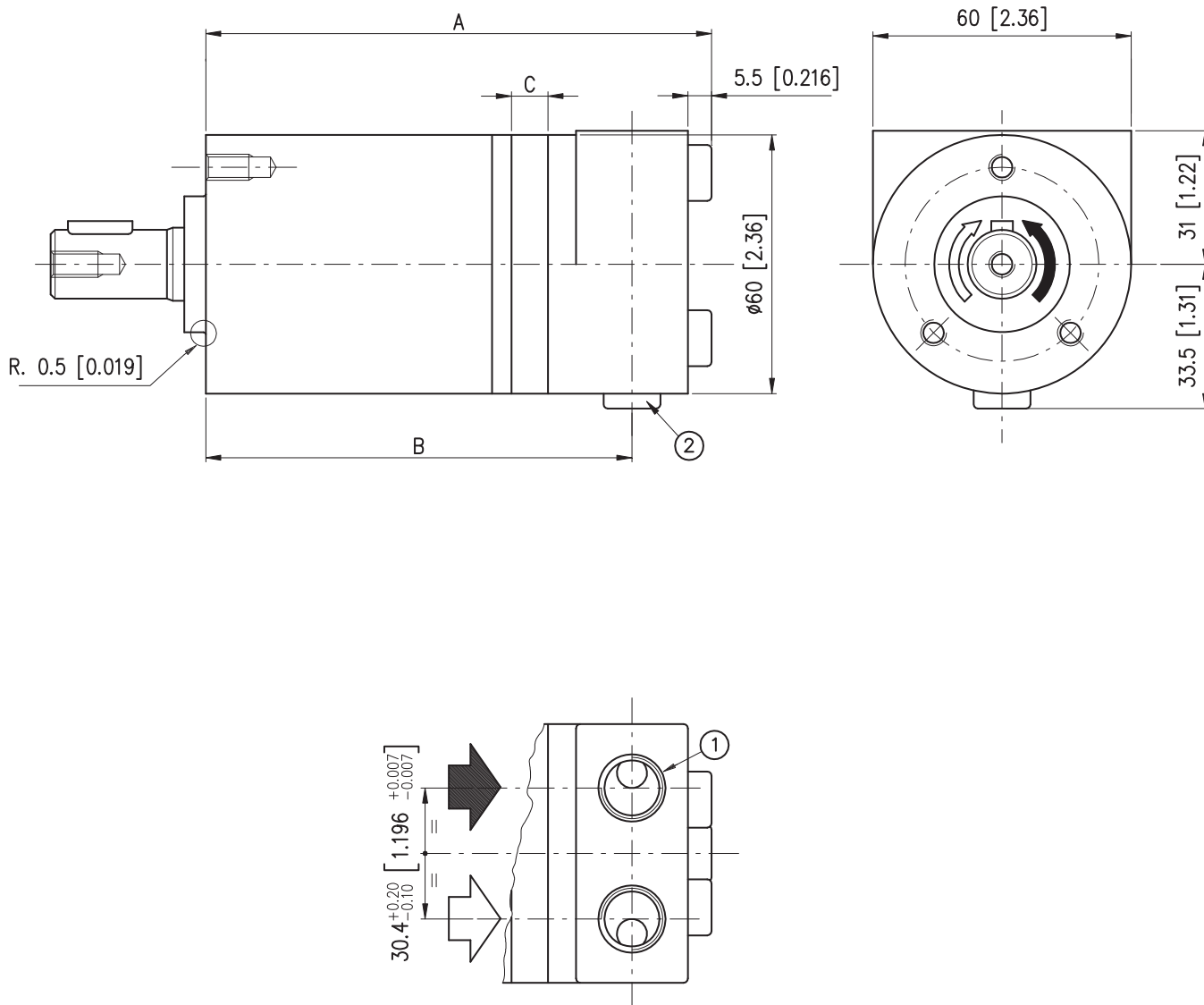

**ATTACCHI M06 / M06 MAIN PORTS**

- 1) N.2 Fori di alimentazione 3/8 G (BSPP) prof. filetto 12mm  
N.2 3/8 G (BSPP) main ports thread depth [0.472 in]
- 2) Drenaggio motore 1/8 G (BSPP) prof. filetto 10mm  
1/8 G (BSPP) drain port thread depth [0.393 in]

**ATTACCHI S06 / S06 MAIN PORTS**

- 1) N.2 Fori di alimentazione 9/16"-18 UNF prof. filetto 13mm  
N.2 9/16"-18 UNF main ports thread depth [0.511 in]
- 2) Drenaggio motore 7/16"-20 UNF prof. filetto 12mm  
7/16"-20 UNF drain port thread depth [0.472 in]

		<b>BGM 013</b>	<b>BGM 020</b>	<b>BGM 032</b>	<b>BGM 040</b>	<b>BGM 050</b>
<b>A</b>	<b>mm [in]</b>	113.8 [4.48]	116.8 [4.59]	121.8 [4.79]	125.3 [4.93]	129.3 [5.09]
<b>B</b>	<b>mm [in]</b>	95.3 [3.75]	98.3 [3.87]	103.3 [4.06]	106.8 [4.20]	110.8 [4.36]
<b>C</b>	<b>mm [in]</b>	5.5 [0.216]	8.5 [0.334]	13.5 [0.531]	17 [0.66]	21 [0.82]
<b>Pesi - Weight</b>	<b>kg [lb]</b>	2.1 [4.6]	2.16 [4.7]	2.25 [4.9]	2.3 [5]	2.35 [5.1]

**Flangia S Flange**

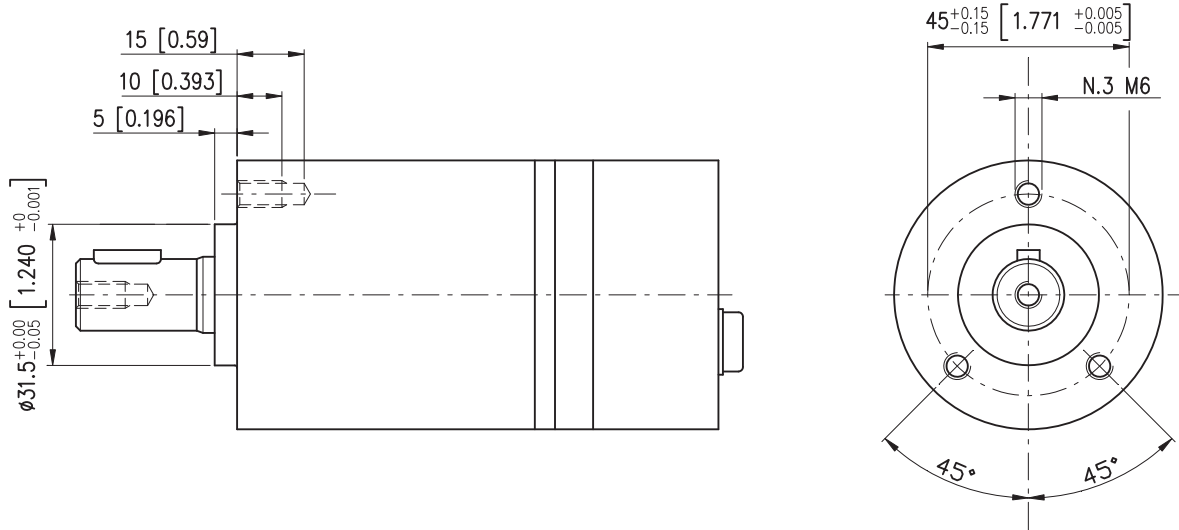

**Flangia T Flange**

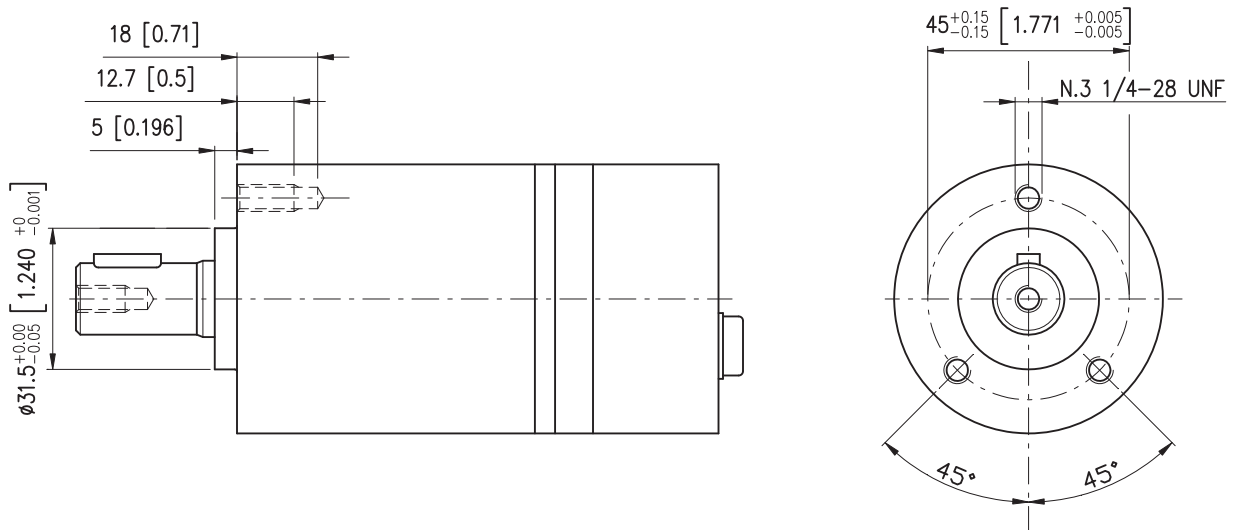

# Flangia N - E Flange

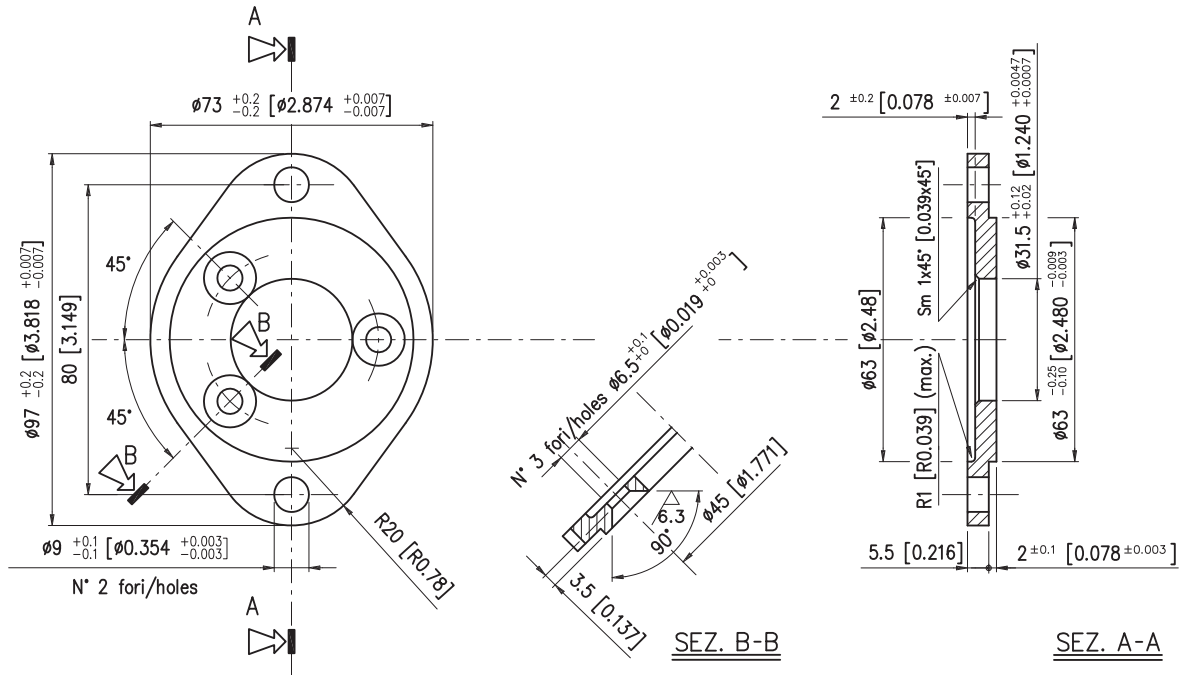

Montaggio flangia / Flange assembling

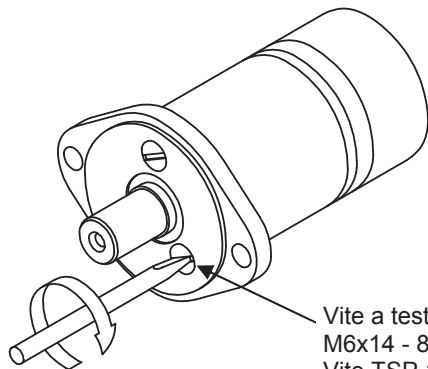

Vite a testa svasata piana con tagli M6x14 - 8.8 UNI 7688 (con flangia S).  
M6x14 - 8.8 UNI 7688 flathead screw (with S flange).  
Vite TSP 1/4-28 UNF 1/2" - 8.8 DIN 965 screw (con flangia T)  
TSP 1/4-28 UNF 1/2" - 8.8 DIN 965 screw (with T flange)

**ALBERO CILINDRICO CL160**  
**CL160 CYLINDRICAL SHAFT**

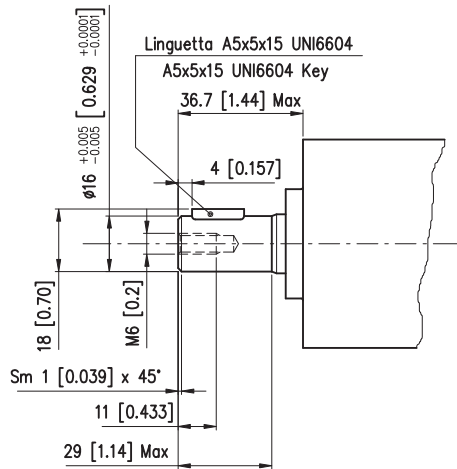

Coppia Massima 39Nm  
Max Torque Continuous 39Nm [28.743 lbf·ft]

**ALBERO SCANALATO SC160**  
**SC160 SPLINED SHAFT**

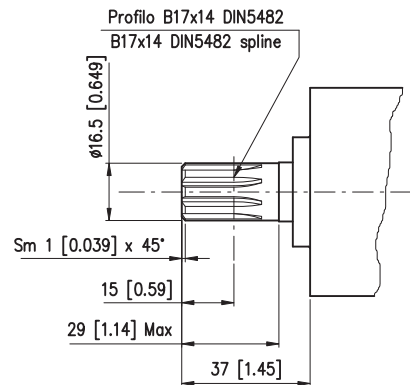

Coppia Massima 44Nm  
Max Torque Continuous 44Nm [32.428 lbf·ft]

**ALBERO CILINDRICO CL158**  
**CL158 CYLINDRICAL SHAFT**

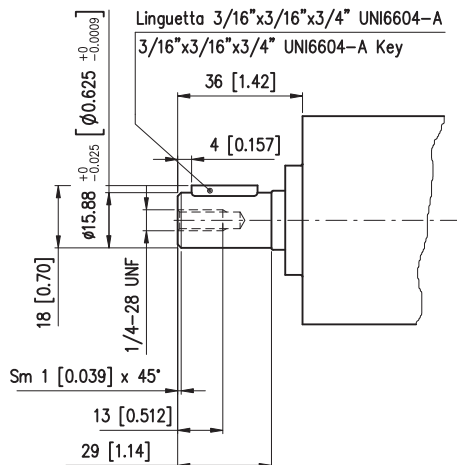

Coppia Massima 39Nm  
Max Torque Continuous 39Nm [28.743 lbf·ft]

**ALBERO CILINDRICO CROSSHOLE CS158**  
**CS158 CYLINDRICAL CROSSHOLE SHAFT**

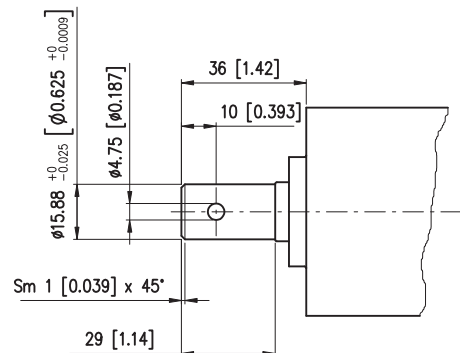

Coppia Massima 39Nm  
Max Torque Continuous 39Nm [28.743 lbf·ft]

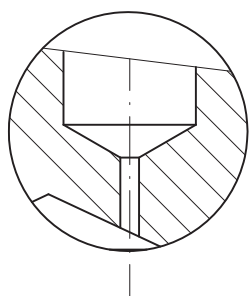
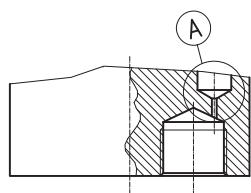

PART. A  
Strozzatore fisso  
Flow restrictor

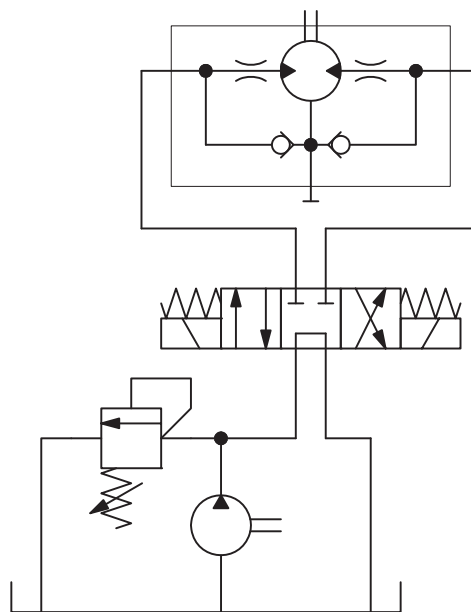

I motori BGM/FRQ dispongono di uno strozzatore sulla parte posteriore del motore che assicura velocità molto basse dell'albero anche in presenza di valori elevati di portata. Una tipica applicazione è quella della rotazione dei tubi di scarico delle turbine da neve montate su autocarri o trattori.

BGM/FRQ motors feature a restrictor at the back of the motor meant to ensure very low shaft speed though in presence of high flow. Typical applications are truck or tractor mounted snow blowers.

CURVE CARATTERISTICHE  
PERFORMANCE CURVES

BGM...FRQ

Curva caratteristica della coppia (Nm) in funzione del numero di giri per le diverse pressioni di taratura della valvola a monte della strozzatura con foro  $D = 1.2 \text{ mm}$  su motore BGM32.

Performance curves (torque/speed) according to pressure relief valve setting and 1.2 mm [0.047 in] diameter (for BGM32) of flow restrictor.

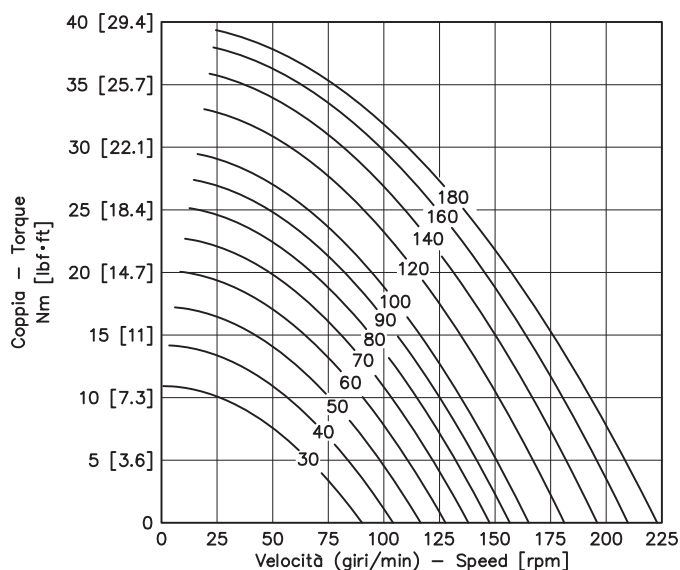



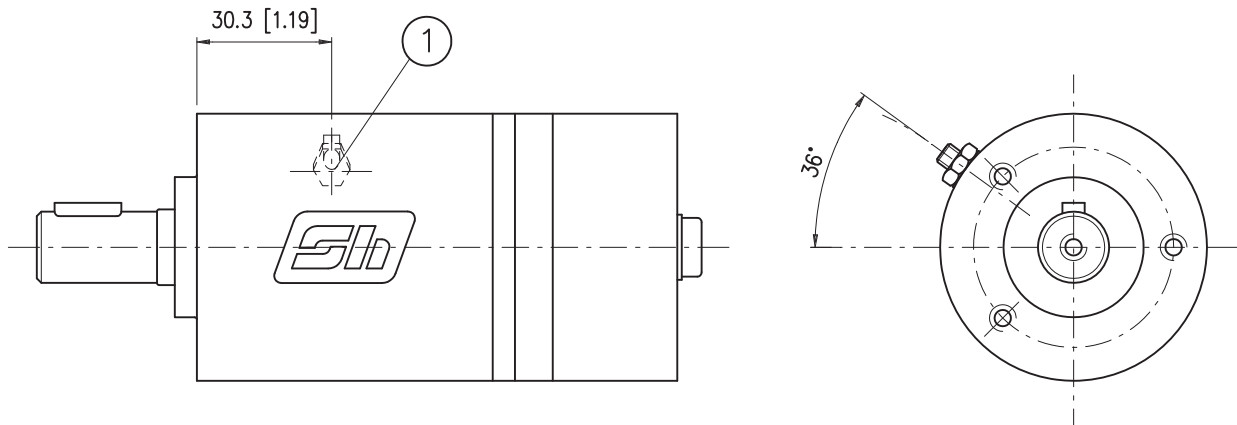

- 1) *Attacco sensore M5x0.5*  
Sensor connection M5x0.5

**KIT SENSORE  
SENSOR KIT**

1. *Cod. 424.0090.0000*  
*Sensore induttivo (1A) + dado di fissaggio*  
*M5x0.5 (1B)*  
2. *Cod. 406.0730.0000*  
*Rondella di tenuta GM2000 M5*

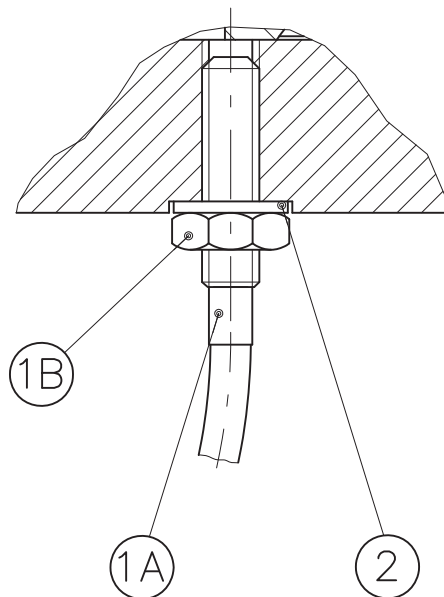

1. *Cod. 424.0090.0000*  
*inductive sensor (1A) + M5x0.5*  
*locking nut (1B)*  
2. *Cod. 406.0730.0000*  
*Sealing washer GM2000 M5*

**Caratteristiche sensore elettronico**

Numero d'impulsi per giro = 4  
 Principio di funzionamento induttivo  
 Funzione di uscita PNP  
 Tensione nominale 10-30 V d.c.  
 Caricabilità massima 200 mA  
 Frequenza massima 3000 Hz  
 Campo di temperatura -25° C +85° C  
 Gradi di protezione IP 67  
 Lunghezza cavo 2 m

**Segnale di uscita in versione elettronica**  
 Output signal electronic tach

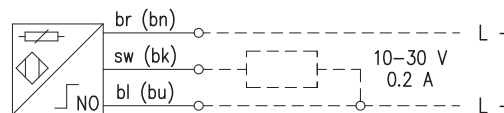
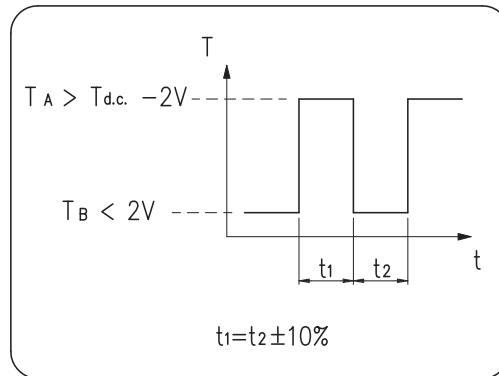

**Electronic sensor technical features**

Number of pulses for revolution = 4  
 Inductive principle  
 Output current PNP  
 Voltage 10-30 V d.c.  
 Max load 200 mA  
 Max frequency 3000 Hz  
 Temperature range -25°C +85°C  
 Enclosure IP 67  
 Cable length 2 m

**SENSO DI ROTAZIONE OTTIMALE  
PREFERENTIAL DIRECTION OF ROTATION**

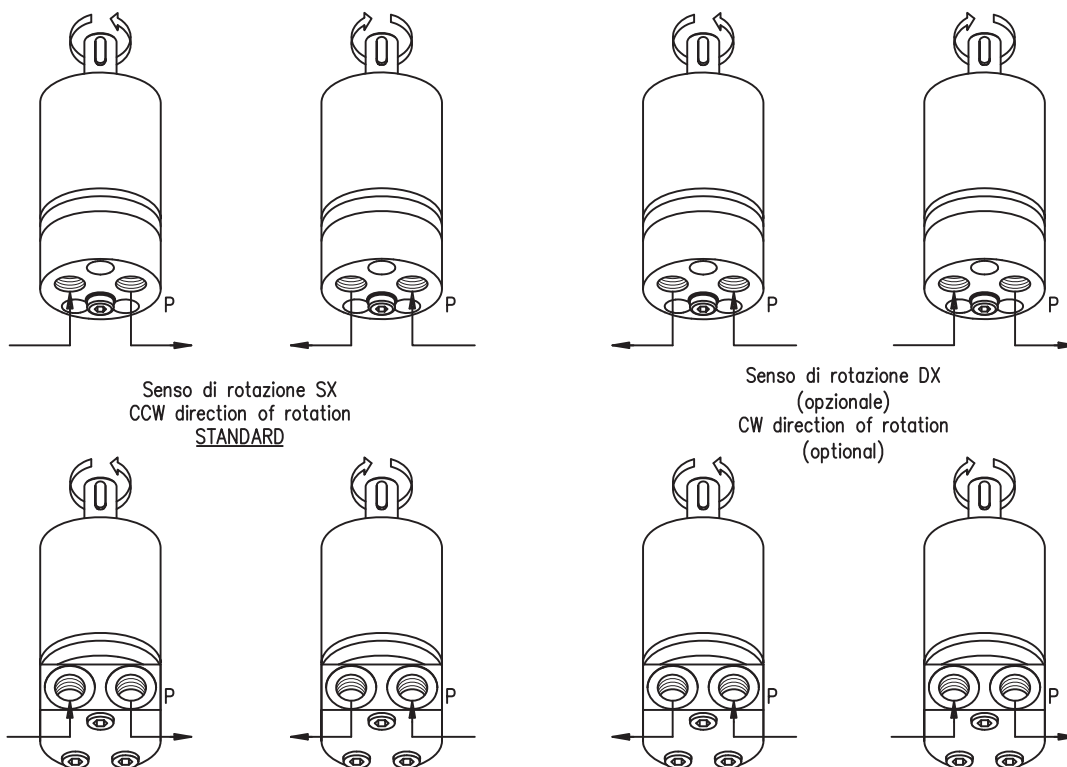

Si consiglia l'impiego della versione SX o DX in funzione del senso di rotazione prevalente del motore, al fine di sottoporre il sensore alla pressione tendenzialmente più bassa.

The selection of the version CW or CCW depends on the prevailing direction of rotation of the motor, in order to use the sensor at the lower working pressure.

## CARICHI AMMESSI SULL'ALBERO SHAFT LOAD CAPACITY

Il carico radiale ammissibile dipende da

- Velocità (n)
- Distanza (L) del punto di carico dalla flangia

The permissible radial shaft load depends on

- Speed (n)
- Distance (L) from the point of load to the mounting flange

Formula utilizzabile per il calcolo del carico radiale (Pr) ai vari numeri di giri e alle varie distanze dalla flangia  
Radial load capacity (Pr) curve according to speed (n) and distance (L) from flange

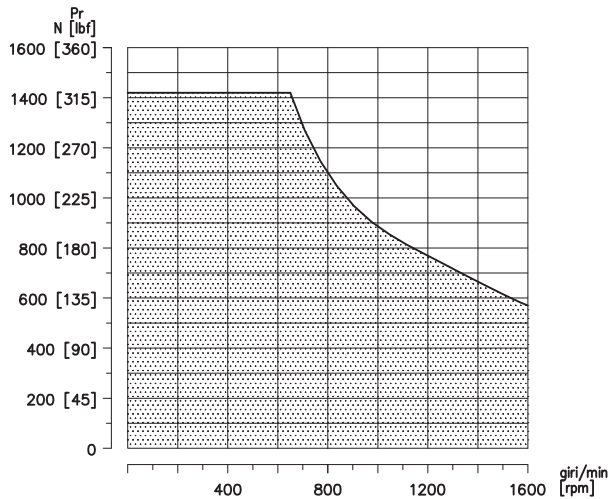

$$Pr = \frac{1500}{n} \cdot \frac{52300}{55.5 + L} (N)$$

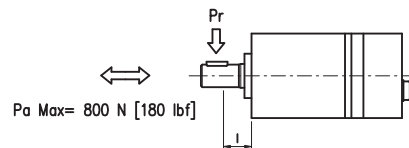

Formula valida per  $n \geq 650$  rpm  
Per  $n < 650$  rpm  $Pr_{max} = 1450$  N

This formula being valid for  $n \geq 650$  rpm  
For  $n < 650$  rpm  $Pr_{max} = 1450$  N [326.25 lbf]

La curva mostra la relazione tra (Pr) e (n)

The curve shows the relation between (Pr) and (n)

- $L = 20$  mm [0.78 in]

## COPPIE DI SERRAGGIO TIGHTENING TORQUE

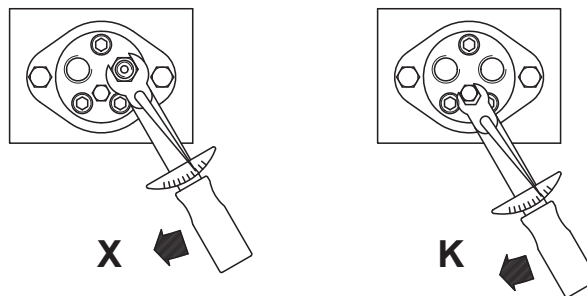

	X	K
<b>Raccordi - Nipples</b>	3/8 G (BSPP)	1/8 G (BSPP)
<b>con rondella in acciaio - with steel washer</b>	60 Nm 44.2 [lbf·ft]	20 Nm 14.7 [lbf·ft]
<b>con rondella in alluminio - with aluminium washer</b>	40 Nm 29.4 [lbf·ft]	10 Nm 7.3 [lbf·ft]
<b>con rondella in rame - with copper washer</b>	60 Nm 44.2 [lbf·ft]	20 Nm 14.7 [lbf·ft]

# BGM 013

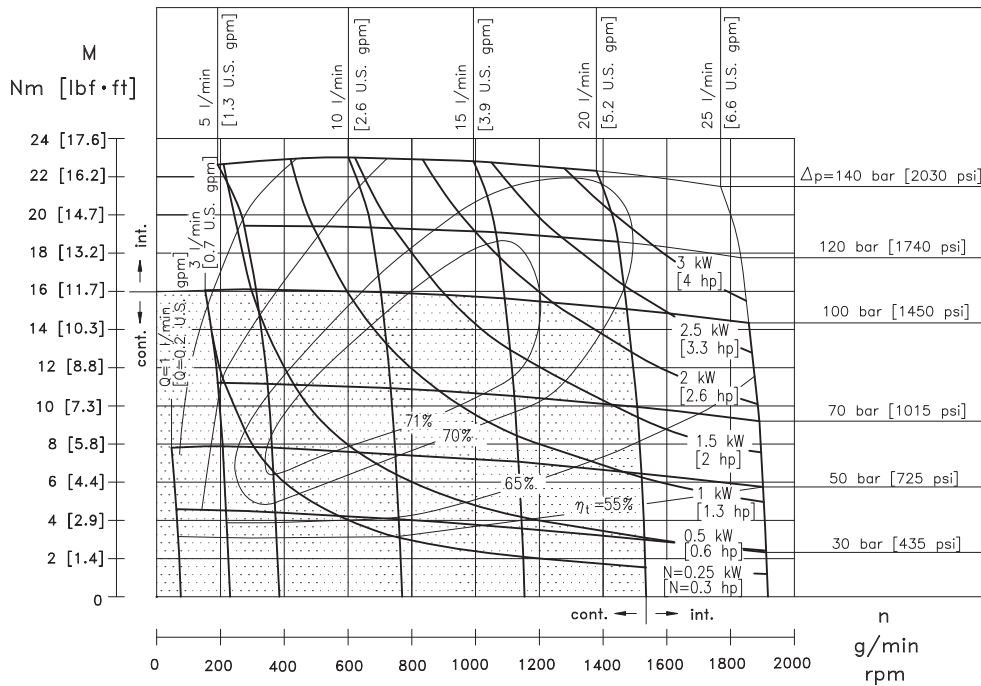

*Pressioni e portate superiori a quelle ammesse in regime continuo non devono essere applicate contemporaneamente.*  
Exceeding continuous pressure values or exceeding flow values indicated, must not occur simultaneously.

# BGM 020

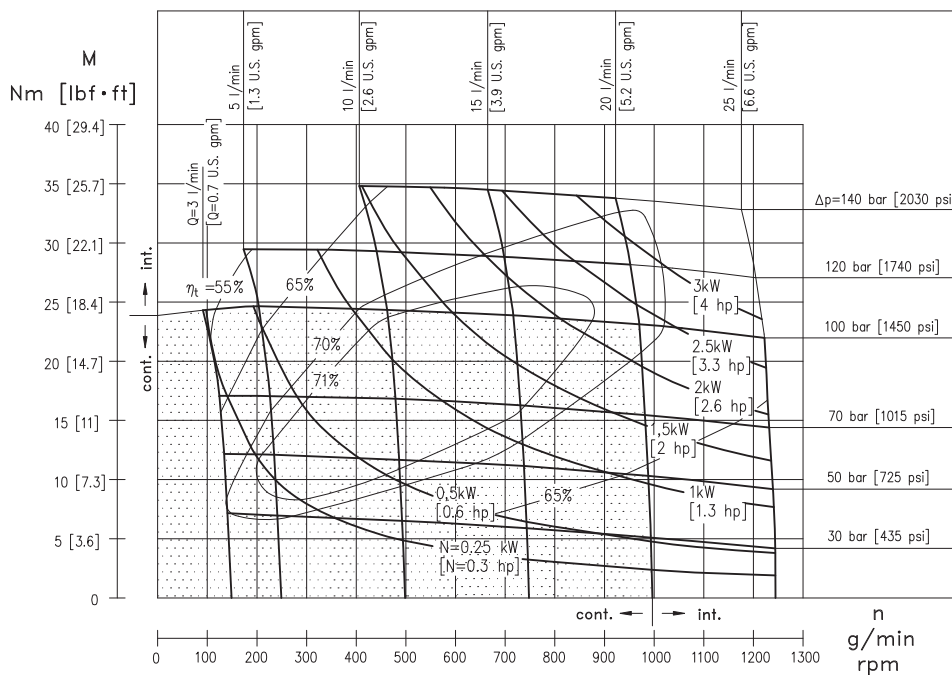

*Pressioni e portate superiori a quelle ammesse in regime continuo non devono essere applicate contemporaneamente.*  
Exceeding continuous pressure values or exceeding flow values indicated, must not occur simultaneously.

# BGM 032

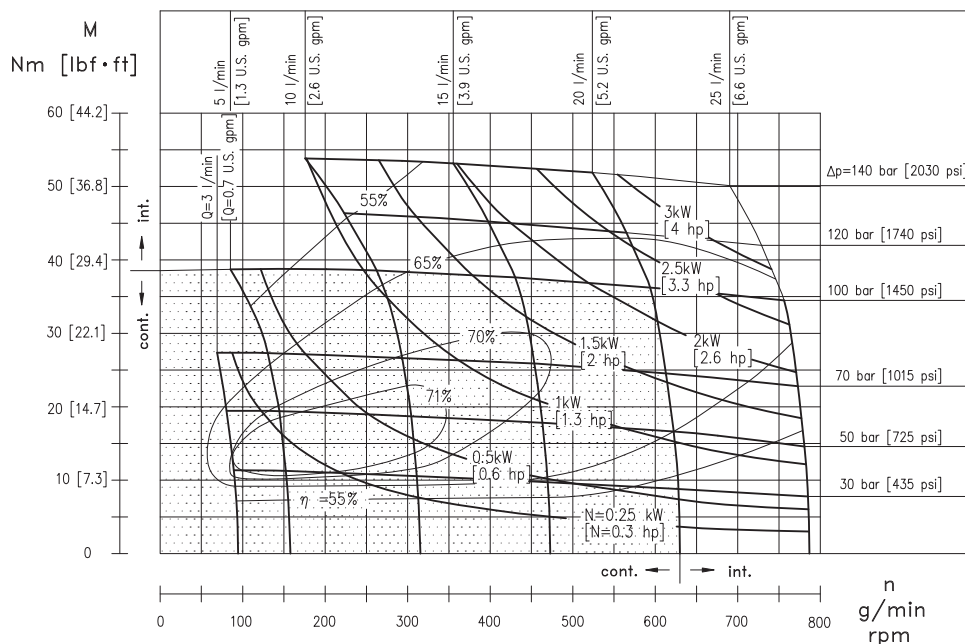

Pressioni e portate superiori a quelle ammesse in regime continuo non devono essere applicate contemporaneamente. Exceeding continuous pressure values or exceeding flow values indicated, must not occur simultaneously.

# BGM 040

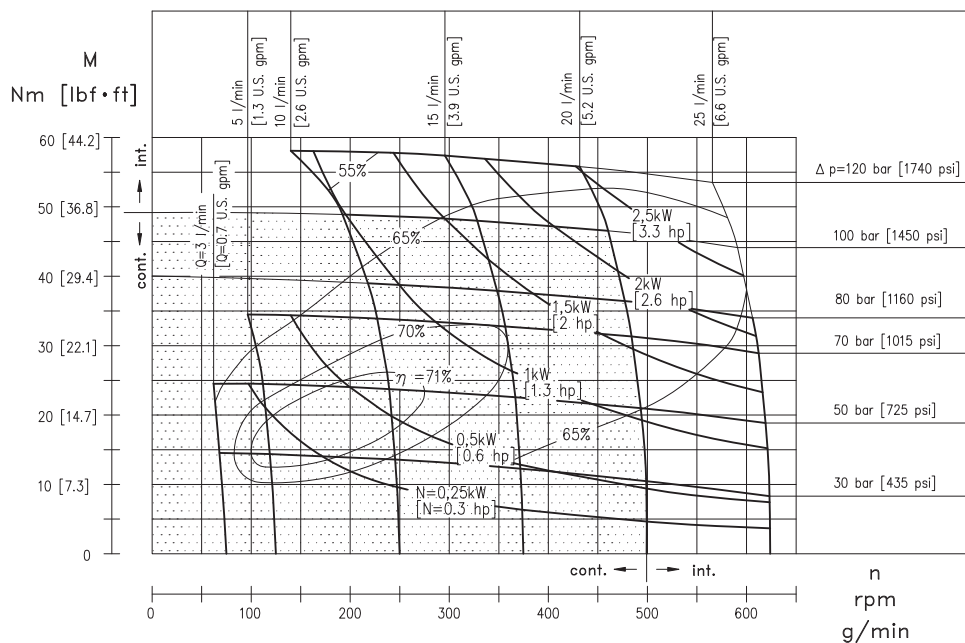

Pressioni e portate superiori a quelle ammesse in regime continuo non devono essere applicate contemporaneamente. Exceeding continuous pressure values or exceeding flow values indicated, must not occur simultaneously.

# BGM 050

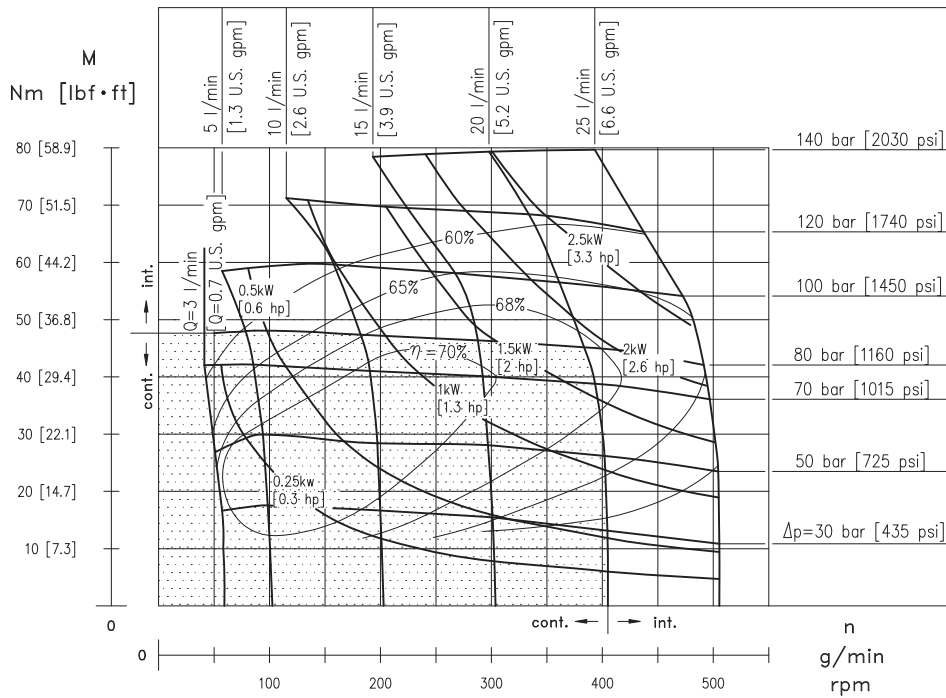

*Pressioni e portate superiori a quelle ammesse in regime continuo non devono essere applicate contemporaneamente.*  
 Exceeding continuous pressure values or exceeding flow values indicated, must not occur simultaneously.



**BREVINI<sup>®</sup>**

*Motion Systems*

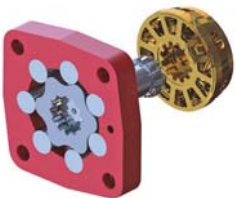
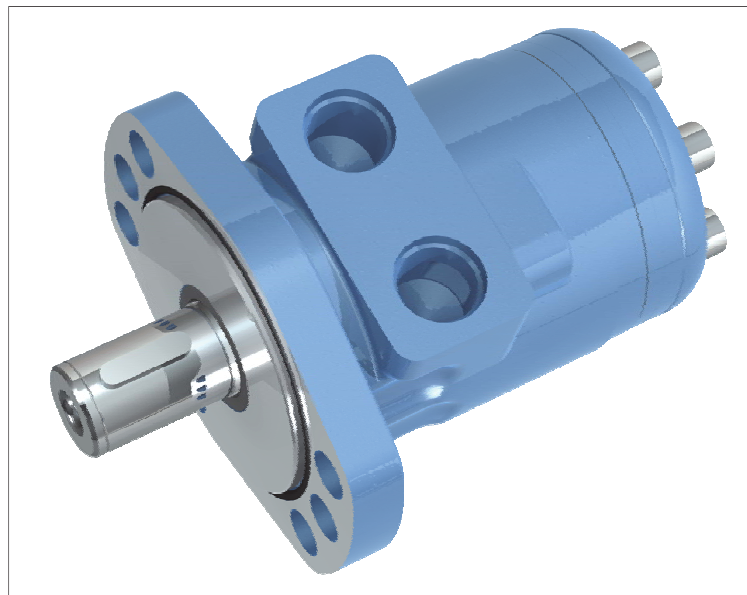

**BG - BH**

***MOTORI ORBITALI***

**ORBITAL MOTORS**

## CARATTERISTICHE DEL MOTORE MOTOR FEATURES

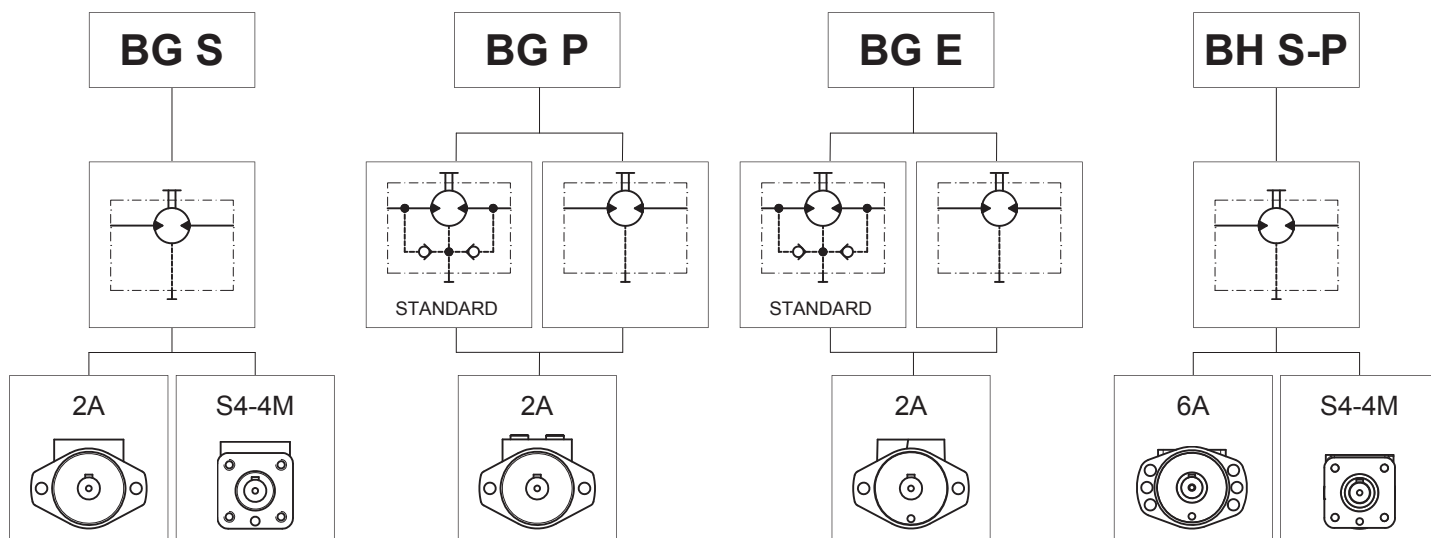

Una ampia gamma di valvole flangiabili, è disponibile su richiesta.  
A wide range of flangeable valves are available on request.

Foro di drenaggio posteriore per un facile collegamento.  
Rear drain port for easier connection.

Flangia a 2 e 4 fori.  
2 bolts and 4 bolts mounting flange option.

Albero cilindrico  $\varnothing 25$  mm e  $\varnothing 25.4$  mm oppure scanalato  $\varnothing 25$  mm.  
0.97 in straight, 1 in straight, 0.97 in splined option.

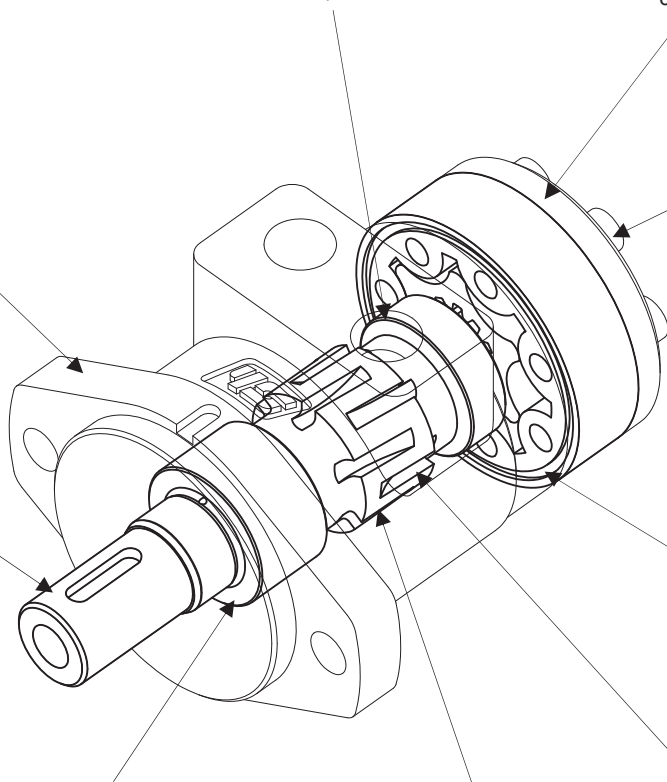

7 viti coperchio posteriore in acciaio ad alta resistenza per sopportare gli sforzi causati dall'alta pressione.  
7 rear cover bolts made of high tensile steel to resist the stress caused by high pressure.

Profilo del gerotor del tipo ad alto rendimento per elevate prestazioni e durata.  
High efficiency profile gerotor set.

Parapolvere per proteggere la guarnizione dell'albero dalle impurità.  
Dust seal to protect the seal from dust.

Valvola di distribuzione integrata nell'albero di distribuzione. Tolleranze molto ridotte assicurano un basso drenaggio.  
Spool valve integral to the output shaft featuring optimized clearance geometry and so minimizing the oil slippage.

Il profilo delle cave assicura un azionamento morbido e silenzioso anche alle velocità più basse.  
Optimized grooves profile to ensure smooth and quiet running even at very low speed.



**DATI TECNICI PER MOTORE BG CON ALBERI CL250-CL254**  
**BG MOTOR TECHNICAL DATA WITH CL250-CL254 PARALLEL KEYED SHAFT**

Motore Motor	Cilindrata Displacement	Pressione max ingresso Max. input pressure		Pressione diff. max. Max. differential pressure		Coppia max. Max. torque		Portata max. Max. flow		Velocità max. Max. speed		Potenza max. Max. power	
	cm <sup>3</sup> /rev [in <sup>3</sup> /rev]	bar [psi]		bar [psi]		Nm [lbf-ft]		l/min [U.S. gpm]		giri/min [rpm]		kW [hp]	
<b>BG 050</b>	47.8 [2.91]	Cont Int <sup>(1)</sup> Peak <sup>(2)</sup>	165 [2392] 200 [2900] 225 [3262]	Cont Int <sup>(1)</sup> Peak <sup>(2)</sup>	140 [2030] 175 [2540] 225 [3262]	Cont Int <sup>(1)</sup>	91 [67.1] 115 [84.7]	Cont Int <sup>(1)</sup>	60 [15.9] 75 [19.8]	Cont Int <sup>(1)</sup>	1220 1530	Cont Int <sup>(1)</sup>	10 [13.4] 12 [16.1]
<b>BG 080</b>	71.9 [4.38]	Cont Int <sup>(1)</sup> Peak <sup>(2)</sup>	165 [2392] 200 [2900] 225 [3262]	Cont Int* Peak <sup>(2)</sup>	140 [2030] 175 [2540] 225 [3262]	Cont Int*	135 [99.5] 175 [128.9]	Cont Int <sup>(1)</sup>	60 [15.9] 75 [19.8]	Cont Int <sup>(1)</sup>	820 1025	Cont Int <sup>(1)</sup>	9.5 [12.7] 12 [16.1]
<b>BG 100</b>	100.1 [6.10]	Cont Int <sup>(1)</sup> Peak <sup>(2)</sup>	165 [2392] 200 [2900] 225 [3262]	Cont Int <sup>(1)</sup> Peak <sup>(2)</sup>	140 [2030] 175 [2540] 225 [3262]	Cont Int <sup>(1)</sup>	190 [140] 230 [169.5]	Cont Int <sup>(1)</sup>	60 [15.9] 75 [19.8]	Cont Int <sup>(1)</sup>	590 740	Cont Int <sup>(1)</sup>	10.5 [14] 13 [17.4]
<b>BG 130</b>	127.2 [7.76]	Cont Int <sup>(1)</sup> Peak <sup>(2)</sup>	165 [2392] 200 [2900] 225 [3262]	Cont Int <sup>(1)</sup> Peak <sup>(2)</sup>	140 [2030] 175 [2540] 225 [3262]	Cont Int <sup>(1)</sup>	240 [176.8] 290 [213.7]	Cont Int <sup>(1)</sup>	60 [15.9] 75 [19.8]	Cont Int <sup>(1)</sup>	465 585	Cont Int <sup>(1)</sup>	10 [13.4] 12 [16.1]
<b>BG 160</b>	165.3 [10.08]	Cont Int <sup>(1)</sup> Peak <sup>(2)</sup>	165 [2392] 200 [2900] 225 [3262]	Cont Int <sup>(1)</sup> Peak <sup>(2)</sup>	140 [2030] 175 [2540] 225 [3262]	Cont Int <sup>(1)</sup>	300 [221.1] 370 [272.6]	Cont Int <sup>(1)</sup>	60 [15.9] 75 [19.8]	Cont Int <sup>(1)</sup>	355 445	Cont Int <sup>(1)</sup>	10 [13.4] 12 [16.1]
<b>BG 200</b>	192.4 [11.73]	Cont Int <sup>(1)</sup> Peak <sup>(2)</sup>	165 [2392] 200 [2900] 225 [3262]	Cont Int <sup>(1)</sup> Peak <sup>(2)</sup>	115 [1670] 160 [2320] 200 [2900]	Cont Int <sup>(1)</sup>	300 [221.1] 390 [287.4]	Cont Int <sup>(1)</sup>	60 [15.9] 75 [19.8]	Cont Int <sup>(1)</sup>	305 380	Cont Int <sup>(1)</sup>	8 [10.7] 15 [20.1]
<b>BG 250</b>	239.1 [14.58]	Cont Int <sup>(1)</sup> Peak <sup>(2)</sup>	165 [2392] 195 [2827] 225 [3262]	Cont Int <sup>(1)</sup> Peak <sup>(2)</sup>	95 [1377] 125 [1810] 180 [2610]	Cont Int <sup>(1)</sup>	300 [221.1] 400 [294.8]	Cont Int <sup>(1)</sup>	60 [15.9] 75 [19.8]	Cont Int <sup>(1)</sup>	245 305	Cont Int <sup>(1)</sup>	6 [8.1] 8 [10.7]
<b>BG 315</b>	286.9 [17.50]	Cont Int <sup>(1)</sup> Peak <sup>(2)</sup>	165 [2392] 195 [2827] 225 [3262]	Cont Int <sup>(1)</sup> Peak <sup>(2)</sup>	80 [1160] 105 [1522] 160 [2320]	Cont Int <sup>(1)</sup>	300 [221.1] 400 [294.8]	Cont Int <sup>(1)</sup>	60 [15.9] 75 [19.8]	Cont Int <sup>(1)</sup>	205 255	Cont Int <sup>(1)</sup>	5 [6.7] 7 [9.4]
<b>BG 400</b>	382.5 [23.33]	Cont Int <sup>(1)</sup> Peak <sup>(2)</sup>	165 [2392] 195 [2827] 225 [3262]	Cont Int <sup>(1)</sup> Peak <sup>(2)</sup>	60 [870] 80 [1160] 130 [1890]	Cont Int <sup>(1)</sup>	300 [221.1] 400 [294.8]	Cont Int <sup>(1)</sup>	60 [15.9] 75 [19.8]	Cont Int <sup>(1)</sup>	150 190	Cont Int <sup>(1)</sup>	4 [5.4] 6 [8.1]

**DATI TECNICI PER MOTORE BG CON ALBERO SD250**  
**BG MOTOR TECHNICAL DATA WITH SD250 SPLINED SHAFT**

Motore Tipo Motor Type	Cilindrata Displacement	Pressione max ingresso Max. input pressure		Pressione diff. max. Max. differential pressure		Coppia max. Max. torque		Portata max. Max. flow		Velocità max. Max. speed		Potenza max. Max. power	
	cm <sup>3</sup> /rev [in <sup>3</sup> /rev]	bar [psi]		bar [psi]		Nm [lbf-ft]		l/min [U.S. gpm]		giri/min [rpm]		kW [hp]	
<b>BG 050</b>	47.8 [2.91]	Cont Int <sup>(1)</sup> Peak <sup>(2)</sup>	165 [2392] 200 [2900] 225 [3262]	Cont Int <sup>(1)</sup> Peak <sup>(2)</sup>	140 [2030] 175 [2540] 225 [3262]	Cont Int <sup>(1)</sup>	91 [67.1] 115 [84.7]	Cont Int <sup>(1)</sup>	60 [15.9] 75 [19.8]	Cont Int <sup>(1)</sup>	1220 1530	Cont Int <sup>(1)</sup>	10 [13.4] 12 [16.1]
<b>BG 080</b>	71.9 [4.38]	Cont Int <sup>(1)</sup> Peak <sup>(2)</sup>	165 [2392] 200 [2900] 225 [3262]	Cont Int* Peak <sup>(2)</sup>	140 [2030] 175 [2540] 225 [3262]	Cont Int*	135 [99.5] 175 [128.9]	Cont Int <sup>(1)</sup>	60 [15.9] 75 [19.8]	Cont Int <sup>(1)</sup>	820 1025	Cont Int <sup>(1)</sup>	9.5 [12.7] 12 [16.1]
<b>BG 100</b>	100.1 [6.10]	Cont Int <sup>(1)</sup> Peak <sup>(2)</sup>	165 [2392] 200 [2900] 225 [3262]	Cont Int <sup>(1)</sup> Peak <sup>(2)</sup>	140 [2030] 175 [2540] 225 [3262]	Cont Int <sup>(1)</sup>	190 [140] 230 [169.5]	Cont Int <sup>(1)</sup>	60 [15.9] 75 [19.8]	Cont Int <sup>(1)</sup>	590 740	Cont Int <sup>(1)</sup>	10.5 [14] 13 [17.4]
<b>BG 130</b>	127.2 [7.76]	Cont Int <sup>(1)</sup> Peak <sup>(2)</sup>	165 [2392] 200 [2900] 225 [3262]	Cont Int <sup>(1)</sup> Peak <sup>(2)</sup>	140 [2030] 175 [2540] 225 [3262]	Cont Int <sup>(1)</sup>	240 [176.8] 290 [213.7]	Cont Int <sup>(1)</sup>	60 [15.9] 75 [19.8]	Cont Int <sup>(1)</sup>	465 585	Cont Int <sup>(1)</sup>	10 [13.4] 12 [16.1]
<b>BG 160</b>	165.3 [10.08]	Cont Int <sup>(1)</sup> Peak <sup>(2)</sup>	165 [2392] 200 [2900] 225 [3262]	Cont Int <sup>(1)</sup> Peak <sup>(2)</sup>	140 [2030] 175 [2540] 225 [3262]	Cont Int <sup>(1)</sup>	300 [221.1] 370 [272.7]	Cont Int <sup>(1)</sup>	60 [15.9] 75 [19.8]	Cont Int <sup>(1)</sup>	355 445	Cont Int <sup>(1)</sup>	10 [13.4] 12 [16.1]
<b>BG 200</b>	192.4 [11.73]	Cont Int <sup>(1)</sup> Peak <sup>(2)</sup>	165 [2392] 200 [2900] 225 [3262]	Cont Int <sup>(1)</sup> Peak <sup>(2)</sup>	140 [2030] 175 [2540] 225 [3262]	Cont Int <sup>(1)</sup>	360 [265.3] 420 [309.5]	Cont Int <sup>(1)</sup>	60 [15.9] 75 [19.8]	Cont Int <sup>(1)</sup>	305 380	Cont Int <sup>(1)</sup>	10 [13.4] 12 [16.1]
<b>BG 250</b>	239.1 [14.58]	Cont Int <sup>(1)</sup> Peak <sup>(2)</sup>	165 [2392] 195 [2827] 225 [3262]	Cont Int <sup>(1)</sup> Peak <sup>(2)</sup>	110 [1595] 140 [2030] 180 [2610]	Cont Int <sup>(1)</sup>	360 [265.3] 440 [324.2]	Cont Int <sup>(1)</sup>	60 [15.9] 75 [19.8]	Cont Int <sup>(1)</sup>	245 305	Cont Int <sup>(1)</sup>	8 [10.7] 10 [13.4]
<b>BG 315</b>	286.9 [17.50]	Cont Int <sup>(1)</sup> Peak <sup>(2)</sup>	165 [2392] 195 [2827] 225 [3262]	Cont Int <sup>(1)</sup> Peak <sup>(2)</sup>	90 [1310] 120 [1740] 160 [2320]	Cont Int <sup>(1)</sup>	340 [250.6] 440 [324.2]	Cont Int <sup>(1)</sup>	60 [15.9] 75 [19.8]	Cont Int <sup>(1)</sup>	205 255	Cont Int <sup>(1)</sup>	5.6 [7.8] 7.5 [10.1]
<b>BG 400</b>	382.5 [23.33]	Cont Int <sup>(1)</sup> Peak <sup>(2)</sup>	165 [2392] 195 [2827] 225 [3262]	Cont Int <sup>(1)</sup> Peak <sup>(2)</sup>	70 [1020] 95 [1377] 130 [1890]	Cont Int <sup>(1)</sup>	360 [265.3] 460 [339]	Cont Int <sup>(1)</sup>	60 [15.9] 75 [19.8]	Cont Int <sup>(1)</sup>	150 190	Cont Int <sup>(1)</sup>	4.7 [6.3] 6 [8.1]

<b>MOTORE MOTOR</b>		<b>Press.max.scar.con dren. Max return pressure with drain line bar [psi]</b>	<b>Press.max.avviam.a vuoto Max starting pressure with no load bar [psi]</b>	<b>Coppia minima di spunto Min starting torque Nm [lbf ft]</b>		
<b>BG</b>	<b>050</b>	140 [2030]	10 [145]	A press. diff. max At max $\Delta p$	Cont. Int.	70 [51.6] 90 [66.3]
<b>BG</b>	<b>080</b>	140 [2030]	10 [145]	A press. diff. max At max $\Delta p$	Cont. Int.	105 [77.4] 135 [99.5]
<b>BG</b>	<b>100</b>	140 [2030]	10 [145]	A press. diff. max At max $\Delta p$	Cont. Int.	150 [111] 190 [140]
<b>BG</b>	<b>130</b>	140 [2030]	9 [131]	A press. diff. max At max $\Delta p$	Cont. Int.	190 [140] 240 [177]
<b>BG</b>	<b>160</b>	140 [2030]	8 [116]	A press. diff. max At max $\Delta p$	Cont. Int.	250 [184] 315 [232]
<b>BG</b>	<b>200</b>	140 [2030]	7 [102]	A press. diff. max At max $\Delta p$	Cont. Int.	255 [188] 320 [236]
<b>BG</b>	<b>250</b>	140 [2030]	6 [87]	A press. diff. max At max $\Delta p$	Cont. Int.	265 [195] 345 [254]
<b>BG</b>	<b>315</b>	140 [2030]	6 [87]	A press. diff. max At max $\Delta p$	Cont. Int.	250 [184] 330 [243]
<b>BG</b>	<b>400</b>	140 [2030]	6 [87]	A press. diff. max At max $\Delta p$	Cont. Int.	265 [195] 355 [262]

1) Le condizioni intermittenti non devono durare più del 10% di ogni minuto. Intermittent duty must not exceed 10% every minute.

2) Le condizioni di picco non devono durare più del 1% di ogni minuto. Peak duty must not exceed 1% of every minute.

3) Viscosità dell'olio 35 cSt. - Oil viscosity 35 cSt.

Pressione massima di scarico senza drenaggio o massima pressione nella linea di drenaggio. I motori sono forniti nella versione con guarnizioni standard (diagramma Standard) o nella versione con guarnizioni ad alta pressione (diagramma HPS).

Per condizioni di pressione e velocità non contemplate dal presente grafico si consiglia di contattare Dana Brevini Fluid Power.

N.B.: Sulla versione TAC/U non è possibile installare guarnizioni HPS.

Max. return pressure without drain line or max. pressure in the drain line.

Motor are supplied in standard seal version (Standard chart) or in HPS seal version (HPS chart).

For pressure and speeds not showed in the curve below, please contact Dana Brevini Fluid Power.

N.B.: TAC/U version is not available with HPS seals.

**STANDARD**

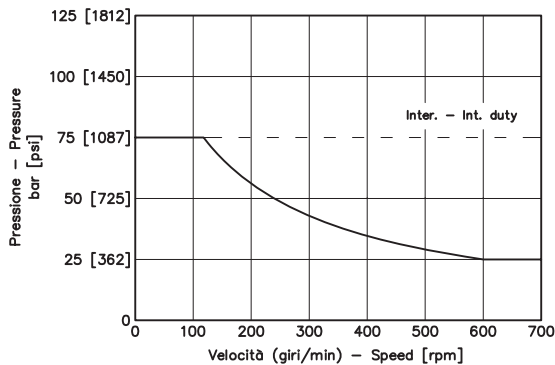

**HPS**

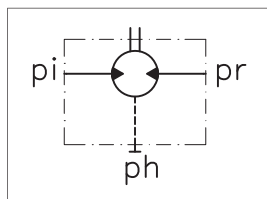
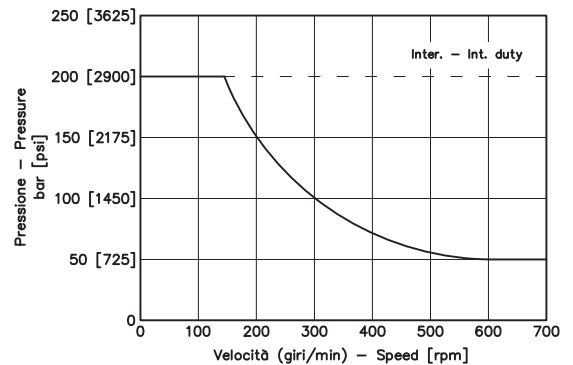

Nei motori senza le valvole interne di drenaggio, la pressione sulla guarnizione (ph) è la media tra le pressioni di alimentazione e di scarico del motore. Se ph supera il valore consentito (vedi grafici in questa pagina), occorre aprire il drenaggio.

In the motors without built-in check valves, the (ph) pressure on the seal is the average between inlet and return pressure. If ph exceeds the allowed values (see the curves in this page), the drain line must be connected.

$$Ph = \frac{pi + pr}{2} [bar]$$

ph = pressione in carcassa  
 pi = pressione di alimentazione  
 pr = pressione di scarico

ph = housing pressure  
 pi = inlet pressure  
 pr = outlet pressure

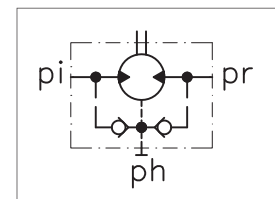

Nei motori con le valvole interne di drenaggio, la pressione sulla guarnizione (ph) è uguale alla pressione di scarico del motore. Se ph supera il valore consentito (vedi grafici in questa pagina), occorre aprire il drenaggio.

In the motors with built-in check valves, the (ph) pressure on the seal is equal to the motor return pressure. If ph exceeds the allowed values (see the curves in this page), the drain line must be connected.

# CODICI DI ORDINAZIONE ORDERING CODES

Le seguenti lettere o numeri del codice, sono state sviluppate per identificare tutte le configurazioni possibili dei motori BG. Usare il seguente modulo per identificare le caratteristiche desiderate. **Tutte le lettere o numeri del codice devono comparire in fase d'ordine.** Si consiglia di leggere attentamente il catalogo prima di iniziare la compilazione del codice di ordinazione.

The following alphanumeric digits system has been developed to identify all of the configuration options for the BG motors. Use the model code below to specify the desired features. **All alphanumeric digits system of the code must be present when ordering.** We recommend to carefully read the catalogue before filling the ordering code.

## CODICE PRODOTTO / MODEL CODE

1	2	3	4	5	6	7	8	9	10	11	12

### 1 - SERIE / SERIES

BG	Motore orbitale Orbital motor
----	----------------------------------

### 2 - CILINDRATA / DISPLACEMENT

050	50 cm <sup>3</sup> /giro [3.05 in <sup>3</sup> /rev]
080	80 cm <sup>3</sup> /giro [4.88 in <sup>3</sup> /rev]
100	100 cm <sup>3</sup> /giro [6.1 in <sup>3</sup> /rev]
130	130 cm <sup>3</sup> /giro [7.93 in <sup>3</sup> /rev]
160	160 cm <sup>3</sup> /giro [9.76 in <sup>3</sup> /rev]
200	200 cm <sup>3</sup> /giro [12.2 in <sup>3</sup> /rev]
250	250 cm <sup>3</sup> /giro [15.25 in <sup>3</sup> /rev]
315	315 cm <sup>3</sup> /giro [19.21 in <sup>3</sup> /rev]
400	400 cm <sup>3</sup> /giro [24.4 in <sup>3</sup> /rev]

### 3 - VERSIONE / VERSION

S	Versione S S Version	STANDARD
E	Versione E E Version	
P	Versione P P Version	

### 4 - FLANGIA / MOUNTING FLANGE

		VERSIONE / VERSION			
		S	E	P	
2A	Ovale 2 Fori Oval 2 Bolts	STANDARD	•	•	•
S4	4 fori 3/8 16 UNC - Ø44,45mm 4 Bolt 3/8 16 UNC - Ø1.75 in		•	/	/
4M	4 fori M10 - Ø44,45mm 4 Bolt M10 - Ø1.75 in		•	/	/

• Disponibile - Available / Non Disponibile - Not Available

### 5 - ESTREMITÀ ALBERO / OUTPUT SHAFT

CL250	Albero Cilindrico Ø25 mm 0.97 in Parallel keyed	STANDARD
CL254	Albero Cilindrico Ø25.4 mm 1 in Parallel keyed	
SD250	Albero Scanalato (profilo SAE 6B 1" Z6) Splined Shaft (SAE 6B 1" 6T spline)	

1	2	3	4	5	6	7	8	9	10	11	12
---	---	---	---	---	---	---	---	---	----	----	----

### 6 - ATTACCO/ MAIN PORT

			VERSIONE / VERSION		
			S	E	P
M08	Attacchi 1/2 G BSPP (40x8) 1/2 G BSPP (40x8) Main Ports	STANDARD	•	/	/
F08	Attacchi Frontali 1/2 G BSPP 1/2 G BSPP (End Main Ports)		/	/	•
R08	Attacchi 1/2 G BSPP (36x36) 1/2 G BSPP (36x36) Main Ports		/	•	/

• Disponibile - Available / Non Disponibile - Not Available

### 7 - TENUTA / SEAL

N	NBR	STANDARD
V	FKM	Non disponibile in versione HPS Not available in HPS version

### 8 - VALVOLA / VALVE

			ATTACCO / MAIN PORT		
			M08	F08	R08
XXXX	Non Richieste Not Required	STANDARD	•	•	•
M081	Valvola di massima pressione VAF 08 - D VAF 08 - D pressure relief valve		•	/	/
M082	Valvola di massima pressione VAF 08 - D/AF VAF 08 - D/AF pressure relief valve		•	/	/
M083	Valvola Antiurto e Anticavitazione VAAF 31 VAAF 31 anticavitation and Anti-Shock Valve		•	/	/
M084	Valvola con prelievo del fluido in pressione AF AF shuttle-valve		•	/	/
M085	Valvola bilanciata di blocco e controllo discesa VCD 08 - S/AF VCD 08 - S/AF overcentre Valve		•	/	/
M086	Valvola di controllo bilanciata a doppio effetto VCR1 08 - D/AF VCR1 08 - D/AF double-acting overcentre valve with shuttle valve		•	/	/
M087	Valvola di controllo bilanciata a doppio effetto con valvola limitatrice di pressione VCR1 08 D/AF LDP VCR1 08 D/AF LDP double-acting overcentre valve with shuttle valve		•	/	/
R081 <sup>(1)</sup>	Valvola di massima pressione VAF E8 - D VAF E8 - D pressure relief valve		/	/	•
R082 <sup>(1)</sup>	Valvola bilanciata di blocco e controllo discesa VCD E8 - S/AF VCD E8 - S/AF overcentre Valve		/	/	•
R083 <sup>(1)</sup>	Valvola di controllo bilanciata a doppio effetto VCR1 E8 - D/AF VCR1 E8 - D/AF double-acting overcentre valve with shuttle valve		/	/	•
R084 <sup>(1)</sup>	Valvola di controllo bilanciata a doppio effetto con valvola limitatrice di pressione VCR1 E8 D/AF LDP VCR1 E8 D/AF LDP double-acting overcentre valve with shuttle valve		/	/	•

• Disponibile - Available / Non Disponibile - Not Available

(1) Attenzione: quantità minima per ordine 20 pezzi

(1) Warning: minimum quantity for order 20 pieces

1	2	3	4	5	6	7	8	9	10	11	12
---	---	---	---	---	---	---	---	---	----	----	----

### 9 - CARATTERISTICA VALVOLA / VALVE FEATURE

		STANDARD	VALVOLA / VALVE											
			XXXX	M081	M082	M083	M084	M085	M086	M087	R081	R082	R083	R084
000	Caratteristica non necessaria Feature not necessary	STANDARD	●	/	/	/	●	/	/	/	/	/	/	/
028	Non Tarata (Campo Taratura 30+70 bar) Not Set [435 to 1015 psi]		/	●	●	/	/	/	/	/	/	/	/	/
017	Non Tarata (Campo Taratura 70+200 bar) Not Set [1015 to 2900 psi]		/	●	●	/	/	/	/	/	/	/	/	/
031	Non Tarata (Campo Taratura 50+130 bar) Not Set [725 to 1885 psi]		/	/	/	●	/	/	/	/	●	/	/	/
021	Non Tarata (Campo Taratura 100+250 bar) Not Set [1450 to 3625 psi]		/	/	/	●	/	/	/	/	/	/	/	/
020	Non Tarata (Campo Taratura 100+200 bar) Not Set [1450 to 2900 psi]		/	/	/	/	/	/	/	/	●	/	/	/
425	Rapporto di Pilotaggio 4.25:1 Pilot Ratio 4.25:1		/	/	/	/	/	/	●	●	/	/	●	●
800	Rapporto di Pilotaggio 8:1 Pilot Ratio 8:1		/	/	/	/	/	/	●	●	/	/	/	/
70D	Rapporto di Pilotaggio 7:1 - Senso di rotazione DX Pilot Ratio 7:1 - Direction of rotation CW		/	/	/	/	/	●	/	/	/	/	/	/
35D	Rapporto di Pilotaggio 3.5:1 -- Senso di rotazione DX Pilot Ratio 3.5:1 -- Direction of rotation CW		/	/	/	/	/	●	/	/	/	●	/	/
70S	Rapporto di Pilotaggio 7:1 - Senso di rotazione SX Pilot Ratio 7:1 - Direction of rotation CCW		/	/	/	/	/	●	/	/	/	/	/	/
35S	Rapporto di Pilotaggio 3.5:1 - Senso di rotazione SX Pilot Ratio 3.5:1 - Direction of rotation CCW		/	/	/	/	/	●	/	/	/	●	/	/

● Disponibile - Available / Non Disponibile - Not Available

### 10 - OPZIONE / OPTION

XX	Nessuna Opzione None
----	-------------------------

### 11 - CARATTERISTICA VERSIONE / VERSION FEATURE

		STANDARD	VERSIONE / VERSION		
			S	E	P
QDR	Versione QUAD-RING con Drenaggio posteriore 1/4 G (BSPP) QUAD-RING version with Rear drain 1/4 G (BSPP)	STANDARD	●	●	●
HPS	Guarnizione alta pressione (senza drenaggio posteriore) High Pressure Seal (without Rear Drain)		●	●	●
TC1	Tachimetro TAC/U (con predisposizione per sensore) TAC/U tachometer (with sensor arrangement)		●	/	/
SV0	Versione senza valvole di drenaggio interne + Drenaggio posteriore - 1/4 G (BSPP) Version without built-in check valves + Rear Drain - 1/4 G (BSPP)		/	●	●
SVH	Versione senza valvole di drenaggio interne + Guarnizione alta pressione (senza drenaggio posteriore) Version without built-in check valves + High Pressure Seal (without Rear Drain)		/	●	●
SVA	Versione senza valvole di drenaggio interne + Guarnizione alta pressione + Drenaggio posteriore - 1/4 G (BSPP) Version without built-in check valves + High Pressure Seal + Rear Drain - 1/4 G (BSPP)		/	●	/
DPM	Guarnizione alta pressione + Drenaggio posteriore - 1/4 G (BSPP) High Pressure Seal + Rear Drain - 1/4 G (BSPP)		●	●	/

● Disponibile - Available / Non Disponibile - Not Available

### 12 - VERNICIATURA / PAINTING

XX	Non Verniciato Not Painted	STANDARD
01	Verniciato Nero RAL 9005 Black Painted RAL 9005	
02	Verniciato Blu RAL 5015 Blue Painted RAL 5015	
06	Verniciato Grigio RAL 7015 Grey Painted RAL 7015	
07	Verniciato Grigio RAL 7021 Grey Painted RAL 7021	
22	Verniciato Grigio RAL 7035 Grey Painted RAL 7035	

**Flangia 2A Flange**  
**Attacchi M08 Main ports**

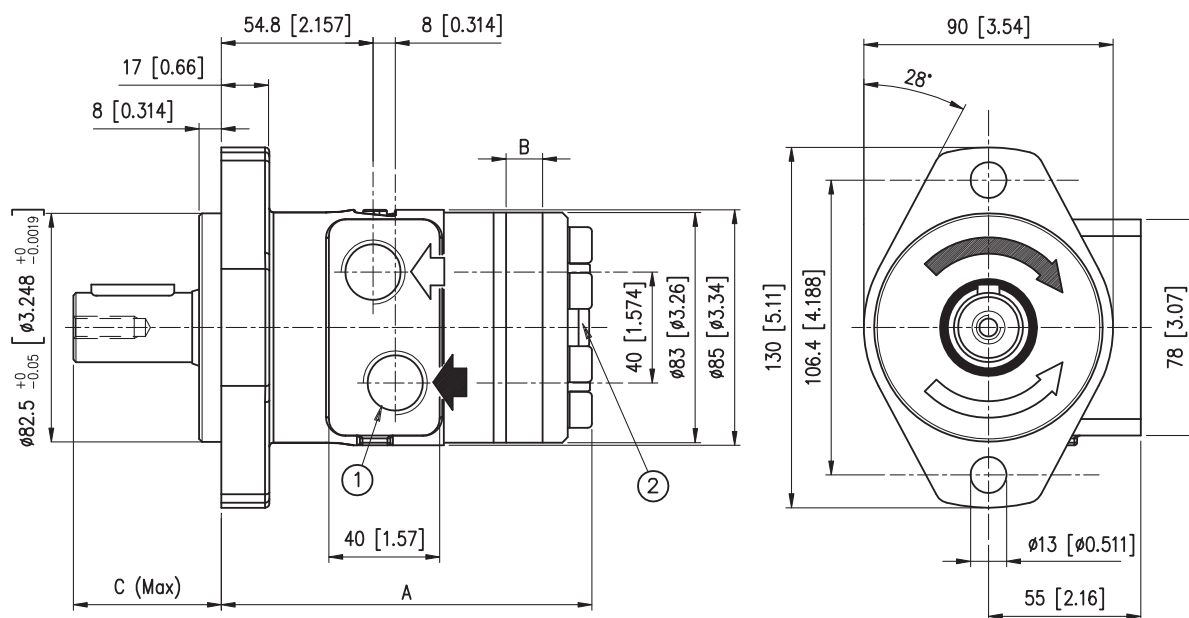

- 1) N° 2 fori di alimentazione 1/2 G (BSPP) profondità filetto 18 mm  
No. 2 1/2 G (BSPP) main ports thread depth 0.70 in
- 2) Drenaggio motore 1/4 G (BSPP) profondità filetto 12 mm  
1/4 G (BSPP) drain motor thread depth 0.472 in

Per le dimensioni degli alberi vedere pagina C/14  
For shafts dimensions see page C/14

ALBERO SHAFT		CL250	CL254	SD250						
C	mm [in]	53.5 [2.10]	53.5 [2.10]	53.5 [2.10]						

		BG S 050	BG S 080	BG S 100	BG S 130	BG S 160	BG S 200	BG S 250	BG S 315	BG S 400
A	mm [in]	127.5 [5.01]	130.5 [5.13]	134.5 [5.29]	138.5 [5.45]	143.5 [5.64]	146.5 [5.76]	153.5 [6.04]	162.5 [6.39]	172.5 [6.79]
B	mm [in]	6.3 [0.248]	9.5 [0.374]	13.3 [0.523]	16.2 [0.63]	21.9 [0.86]	25.5 [1.003]	31.7 [1.24]	38.1 [1.50]	50.8 [2.00]
Peso - Weight	kg [lb]	5.5 [12.1]	5.6 [12.3]	5.8 [12.8]	5.9 [13.0]	6.1 [13.4]	6.3 [13.9]	6.5 [14.3]	6.8 [15.0]	7.3 [16.1]

**Flangia S4 - 4M Flange**  
**Attacchi M08 Main ports**

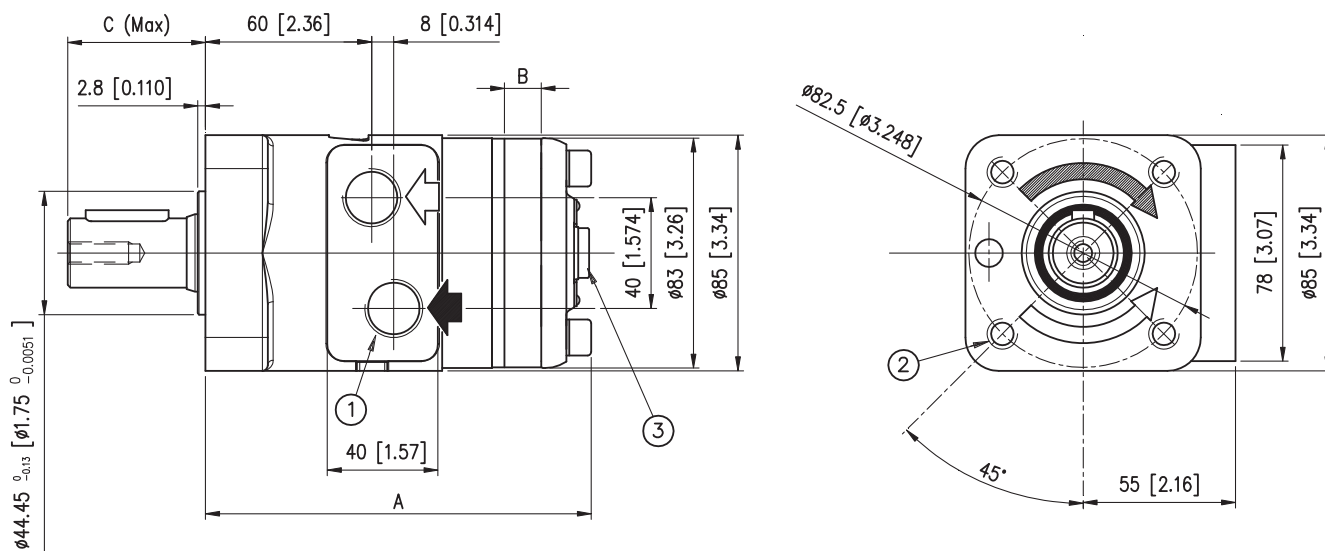

- 1) N° 2 fori di alimentazione 1/2 G (BSPP) profondità filetto 18 mm  
No. 2 1/2 G (BSPP) main ports thread depth 0.70 in
- 2) N° 4 3/8 16UNC profondità filetto 17 mm (Flangia S4)  
No. 4 3/8 16UNC thread depth 0.66 in (S4 flange)  
N° 4 M10 profondità filetto 17 mm (Flangia 4M)  
No. 4 M10 thread depth 0.66 in (4M flange)
- 3) Drenaggio motore 1/4 G (BSPP) profondità filetto 12 mm  
1/4 G (BSPP) drain motor thread depth 0.472 in

Per le dimensioni degli alberi vedere pagina C/14  
For shafts dimensions see page C/14

ALBERO SHAFT		CL250	CL254	SD250						
C	mm [in]	50 [1.96]	45 [1.77]	50 [1.96]						
		<b>BG S 050</b>	<b>BG S 080</b>	<b>BG S 100</b>	<b>BG S 130</b>	<b>BG S 160</b>	<b>BG S 200</b>	<b>BG S 250</b>	<b>BG S 315</b>	<b>BG S 400</b>
A	mm [in]	133.1 [5.24]	136.3 [5.36]	140 [5.51]	143.7 [5.65]	148.7 [5.85]	152.2 [5.99]	158.5 [6.24]	165 [6.49]	177.5 [6.98]
B	mm [in]	6.3 [0.248]	9.5 [0.374]	13.3 [0.523]	16.2 [0.63]	21.9 [0.86]	25.5 [1.003]	31.7 [1.24]	38.1 [1.50]	50.8 [2.00]
Peso - Weight	kg [lb]	5.5 [12.1]	5.6 [12.3]	5.8 [12.8]	5.9 [13.0]	6.1 [13.4]	6.3 [13.9]	6.5 [14.3]	6.8 [15.0]	7.3 [16.1]



**Flangia 2A Flange**  
**Attacchi F08 Main ports**

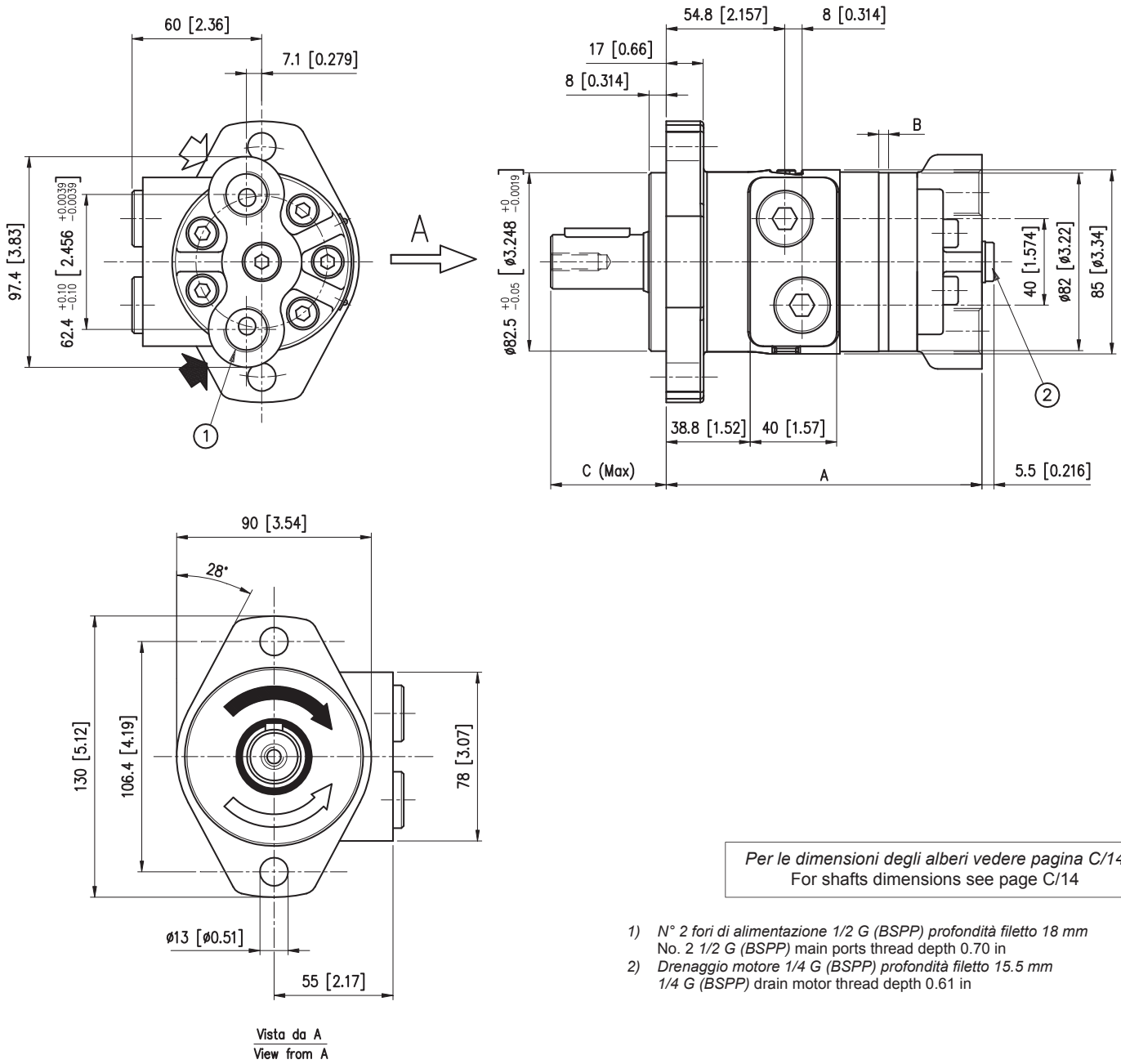

Per le dimensioni degli alberi vedere pagina C/14  
For shafts dimensions see page C/14

- 1) N° 2 fori di alimentazione 1/2 G (BSPP) profondità filetto 18 mm  
No. 2 1/2 G (BSPP) main ports thread depth 0.70 in
- 2) Drenaggio motore 1/4 G (BSPP) profondità filetto 15.5 mm  
1/4 G (BSPP) drain motor thread depth 0.61 in

ALBERO SHAFT		CL250	CL254	SD250						
C	mm [in]	53.5 [2.10]	53.5 [2.10]	53.5 [2.10]						
		<b>BG P 050</b>	<b>BG P 080</b>	<b>BG P 100</b>	<b>BG P 130</b>	<b>BG P 160</b>	<b>BG P 200</b>	<b>BG P 250</b>	<b>BG P 315</b>	<b>BG P 400</b>
A	mm [in]	140 [5.51]	143 [5.62]	147 [5.78]	150.2 [5.91]	155.5 [6.12]	159 [6.25]	165 [6.49]	171.5 [6.75]	187.5 [7.38]
B	mm [in]	6.3 [0.248]	9.5 [0.374]	13.3 [0.523]	16.2 [0.63]	21.9 [0.86]	25.5 [1.003]	31.7 [1.24]	38.1 [1.50]	50.8 [2.00]
Peso - Weight	kg [lb]	6.5 [14.3]	6.6 [14.5]	6.8 [15.0]	6.9 [15.2]	7.1 [15.6]	7.3 [16.1]	7.5 [16.5]	7.8 [17.2]	8.3 [18.3]

**Flangia 2A Flange**  
**Attacchi R08 Main ports**

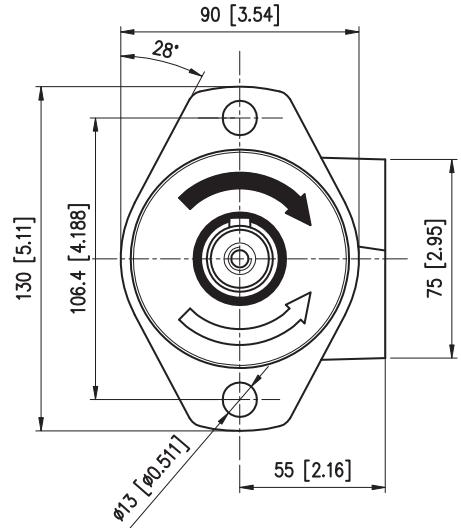
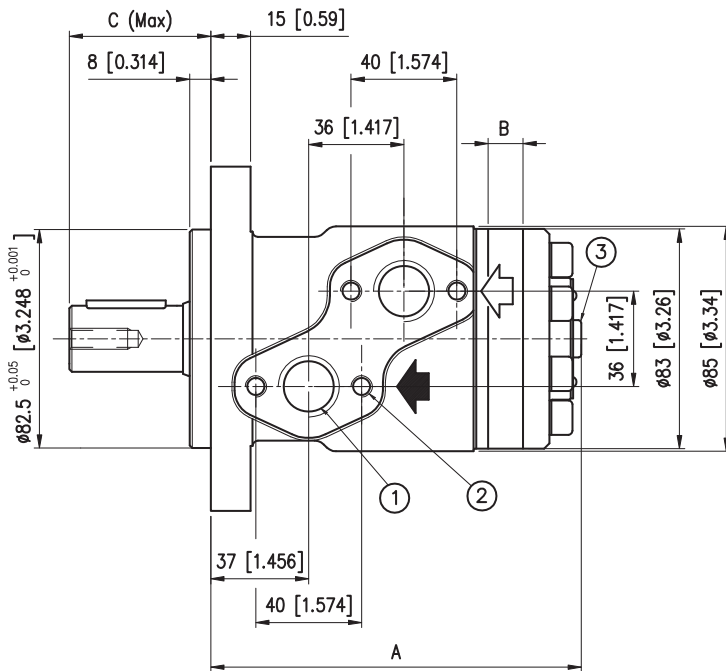

- 1) N° 2 fori di alimentazione 1/2 G (BSPP) profondità filetto 18 mm  
No. 2 1/2 G (BSPP) main ports thread depth 0.70 in
- 2) N° 4 fori M8 tratto utile filetto 16 mm  
No. 4 M8 thread depth 0.62 in
- 3) Drenaggio motore 1/4 G (BSPP) profondità filetto 12 mm  
1/4 G (BSPP) drain motor thread depth 0.472 in

Per le dimensioni degli alberi vedere pagina C/14  
For shafts dimensions see page C/14

ALBERO SHAFT		CL250	CL254	SD250						
C	mm [in]	55 [2.16]	50 [1.96]	55 [2.16]						
		<b>BG E 050</b>	<b>BG E 080</b>	<b>BG E 100</b>	<b>BG E 130</b>	<b>BG E 160</b>	<b>BG E 200</b>	<b>BG E 250</b>	<b>BG E 315</b>	<b>BG E 400</b>
A	mm [in]	127.7 [5.03]	130.9 [5.15]	134.7 [5.30]	138.2 [5.44]	143.3 [5.64]	146.9 [5.78]	153.1 [6.02]	159.5 [6.27]	172.2 [6.78]
B	mm [in]	6.3 [0.248]	9.5 [0.374]	13.3 [0.523]	16.2 [0.63]	21.9 [0.86]	25.5 [1.003]	31.7 [1.24]	38.1 [1.50]	50.8 [2.00]
Peso - Weight	kg [lb]	5.5 [12.1]	5.6 [12.3]	5.8 [12.8]	5.9 [13.0]	6.1 [13.4]	6.3 [13.9]	6.5 [14.3]	6.8 [15.0]	7.3 [16.1]

- 1) Drenaggio motore 1/4 G (BSPP) profondità filetto 12mm  
1/4 G (BSPP) drain motor thread depth 0.472 in
- 2) Attacco sensore M8x1  
Sensor connection M8x1

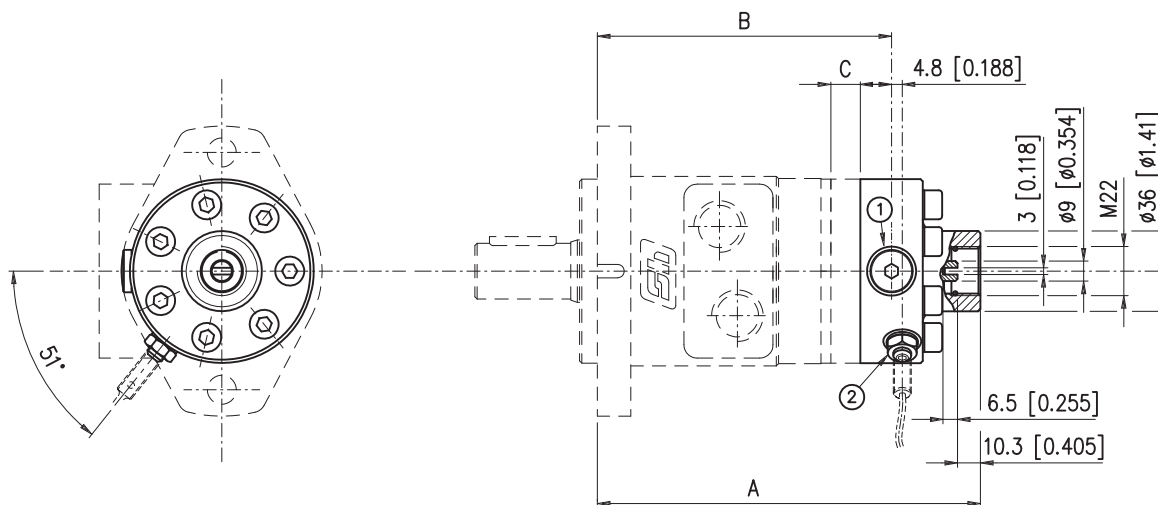

**ATTENZIONE:**

- L'alberino contagiri ha velocità pari a 6 volte quella dell'albero primario del motore e senso di rotazione opposto.
- N.B. Non sono accettati carichi assiali o radiali sull'albero contagiri. Coppia massima trasmissibile 1Nm.
- Il motore viene fornito senza il sensore elettronico: se necessario, richiederlo in fase di ordinazione.
- Pressione massima ammessa sulla guarnizione dell'albero contagiri con drenaggio chiuso: 25 bar.

**WARNING:**

- Tacho shaft has a 6 times higher revolution speed than the motor shaft and opposite direction of rotation.
- NOTE: Axial or radial load on tacho shaft must be avoided. Max torque on tacho 1 Nm [0.73 lbf-ft].
- The electronic sensor is not supplied: if required, please state it clearly on order form.
- Max pressure admissible on the shaft seal with closed drain port 25 bar [363 psi].

		BG S 050	BG S 080	BG S 100	BG S 130	BG S 160	BG S 200	BG S 250	BG S 315	BG S 400
<b>A</b>	<b>mm [in]</b>	163 [6.41]	166 [6.53]	170 [6.69]	174 [6.85]	179 [7.04]	182 [7.16]	189 [7.44]	195 [7.67]	208 [8.18]
<b>B</b>	<b>mm [in]</b>	123 [4.84]	126 [4.96]	130 [5.11]	134 [5.27]	139 [5.47]	142 [5.59]	149 [5.86]	155 [6.10]	168 [6.61]
<b>C</b>	<b>mm [in]</b>	6.3 [0.248]	9.5 [0.374]	13.3 [0.523]	16.2 [0.63]	21.9 [0.86]	25.5 [1.003]	31.7 [1.24]	38.1 [1.50]	50.8 [2.00]
<b>Peso - Weight</b>	<b>kg [lb]</b>	6 [13.2]	6.1 [13.4]	6.3 [13.9]	6.4 [14.1]	6.6 [14.5]	6.8 [15.0]	7.0 [15.4]	7.3 [16.1]	7.8 [17.2]

**CARATTERISTICHE TECNICHE DEL SENSORE ELETTRONICO**  
**ELECTRONIC SENSOR TECHNICAL FEATURES**

Segnale in uscita versione elettronica  
Output signal electronic tacho

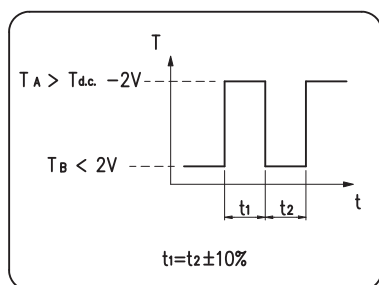

Numero d'impulsi per giro = 90  
Principio di funzionamento induttivo  
Funzione di uscita PNP  
Tensione nominale 10-65 V d.c.  
Caricabilità massima 300 mA  
Frequenza massima 10000 Hz  
Campo di temperatura -25C +85C  
Grado di protezione IP 67

Versioni disponibili:

- Sensore con cavo a tre fili lunghezza 2 metri (cod.424.0050.0000)
- Sensore con attacco per connettore tipo binder (cod.424.0060.0000) + connettore tipo binder
- con cavo a tre fili lunghezza 5 metri (cod.424.0080.0000)

Number of pulses per revolution = 90  
Inductive principle  
Output current PNP  
Voltage 10-65 V d.c.  
Max load 300 mA  
Max frequency 10000 Hz  
Temperature range -25C +85C  
Enclosure IP 67

Available versions:

- Sensor with 2 metres three wires cable (cod.424.0050.0000)
- Sensor with binder plug connection (cod.424.0060.0000) + binder connecting
- plug with 5 metres three wires cable (cod.424.0080.0000)

**ALBERO CILINDRICO CL250  
CL250 CYLINDRICAL SHAFT**

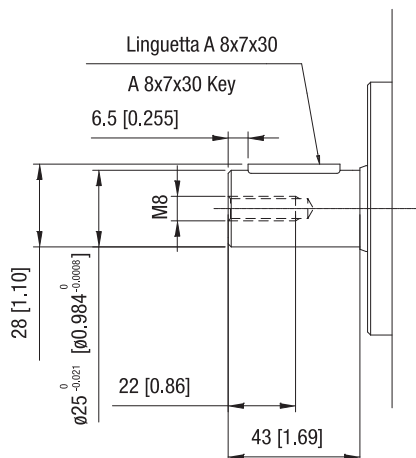

**ALBERO CILINDRICO CL254  
CL254 CYLINDRICAL SHAFT**

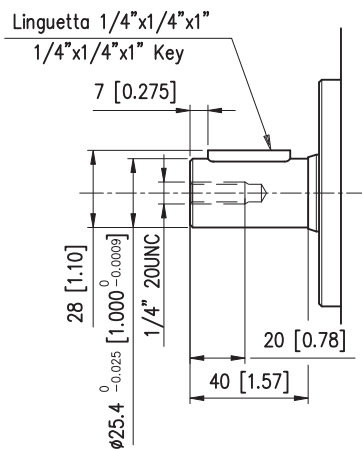

**ALBERO SCANALATO SD250  
SD250 SPLINED SHAFT**

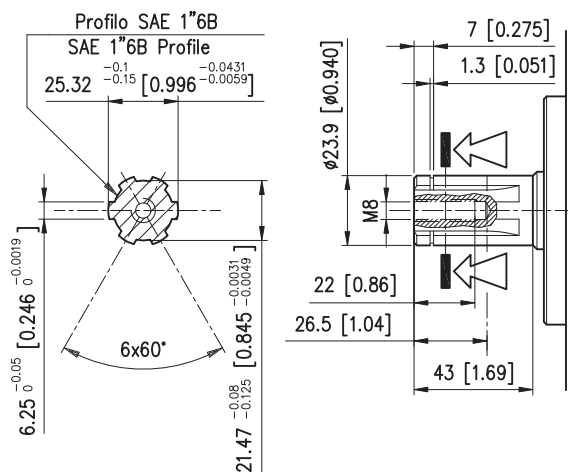

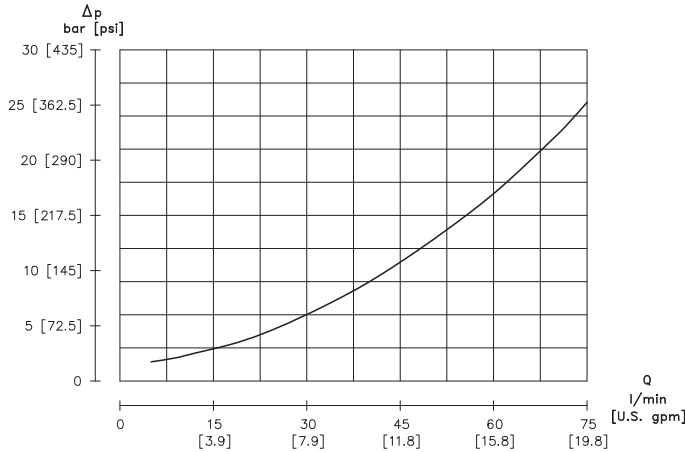

Il diagramma è stato ottenuto con prove eseguite su un numero significativo di motori, utilizzando un'olio avente una viscosità cinematica di 37 cSt alla temperatura di 45° C.

Diagram according to tests done with a huge number of motors and using hydraulic oil with kinematic viscosity of 37 cSt at 45° C temperature.

**CARICHI AMMESSI SULL'ALBERO  
SHAFT LOAD CAPACITY**

I carichi ammessi sull'albero variano in funzione di:

- Velocità (n)
- Distanza (L) dal punto di applicazione del carico alla flangia di montaggio
- Versione della flangia di montaggio

Formula utilizzabile per il calcolo del carico radiale (Pr) ai vari numeri di giri (n), e alle varie distanze (L) dalla flangia tipo "2A" ovale 2 fori.

Radial load capacity (Pr) curve according to speed (n) and distance (L) from flange, valid for the 2-bolt flange type "2A"

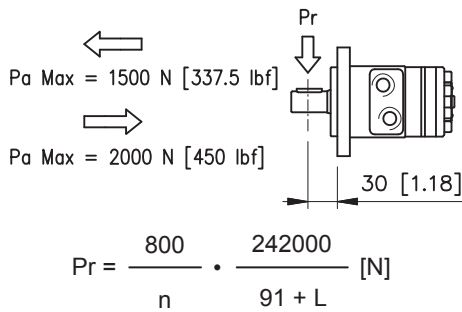

Formula valida per n >= 200 rpm  
Per n < 200 rpm Prmax = 8000 N

This formula being valid for n >= 200 rpm  
For n < 200 rpm Prmax = 8000 N [1800 lbf]

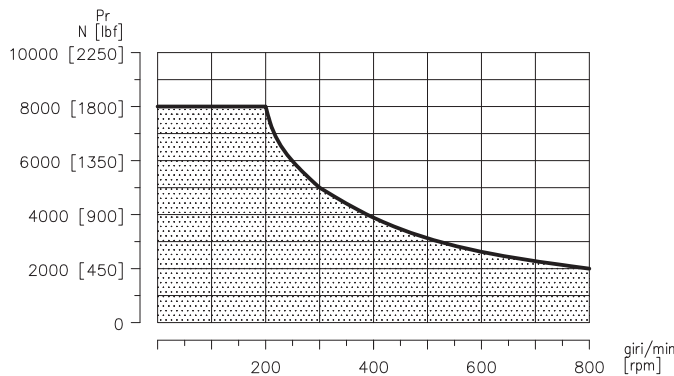

La curva mostra la relazione tra (Pr) e (n) quando:

- L= 30 mm [1.18 in] per motori flangia 2A
- L= 24 mm [0.95 in] per motori flangia S4-4M

The permissible radial shaft load depends on

- Speed (n)
- Distance (L) from the point of load to the mounting flange
- Mounting flange version

Formula utilizzabile per il calcolo del carico radiale (Pr) ai vari numeri di giri (n), e alle varie distanze (L) dalla flangia tipo "S4-4M" 4 fori.

Radial load capacity (Pr) curve according to speed (n) and distance (L) from flange, valid for the 4-bolt flange type "S4-4M".

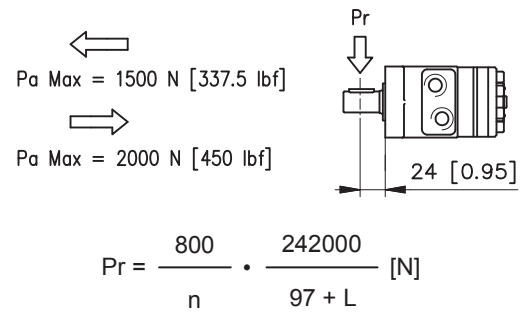

Formula valida per n >= 200 rpm  
Per n < 200 rpm Prmax = 8000 N

This formula being valid for n >= 200 rpm  
For n < 200 rpm Prmax = 8000 N [1800 lbf]

## DATI TECNICI PER MOTORE BH CON ALBERO CL254-CS254-CL250 / BH MOTOR TECHNICAL DATA WITH CL254-CS254-CL250 SHAFT

Motore Motor	Cilindrata Displacement	Pressione max ingresso Max. input pressure		Pressione diff. max. Max. differential pressure		Coppia max. Max. torque		Portata max. Max. flow		Velocità max. Max. speed		Potenza max. Max. power	
	cm <sup>3</sup> /rev [in <sup>3</sup> /rev]	bar [psi]		bar [psi]		Nm [lbf-ft]		l/min [U.S. gpm]		giri/min [rpm]		kW [hp]	
<b>BH 050</b>	47.8 [2.91]	Cont Int <sup>(1)</sup> Peak <sup>(2)</sup>	165 [2392] 200 [2900] 225 [3262]	Cont Int <sup>(1)</sup> Peak <sup>(2)</sup>	140 [2030] 175 [2540] 225 [3262]	Cont Int <sup>(1)</sup>	91 [67.1] 115 [84.7]	Cont Int <sup>(1)</sup>	60 [15.9] 75 [19.8]	Cont Int <sup>(1)</sup>	1220 1530	Cont Int <sup>(1)</sup>	10 [13.4] 12 [16.1]
<b>BH 080</b>	71.9 [4.38]	Cont Int <sup>(1)</sup> Peak <sup>(2)</sup>	165 [2392] 200 [2900] 225 [3262]	Cont Int* Peak <sup>(2)</sup>	140 [2030] 175 [2540] 225 [3262]	Cont Int*	135 [99.5] 175 [128.9]	Cont Int <sup>(1)</sup>	60 [15.9] 75 [19.8]	Cont Int <sup>(1)</sup>	820 1025	Cont Int <sup>(1)</sup>	9.5 [12.7] 12 [16.1]
<b>BH 100</b>	100.1 [6.10]	Cont Int <sup>(1)</sup> Peak <sup>(2)</sup>	165 [2392] 200 [2900] 225 [3262]	Cont Int <sup>(1)</sup> Peak <sup>(2)</sup>	140 [2030] 175 [2540] 225 [3262]	Cont Int <sup>(1)</sup>	190 [140] 230 [169.5]	Cont Int <sup>(1)</sup>	60 [15.9] 75 [19.8]	Cont Int <sup>(1)</sup>	590 740	Cont Int <sup>(1)</sup>	10.5 [14] 13 [17.4]
<b>BH 130</b>	127.2 [7.76]	Cont Int <sup>(1)</sup> Peak <sup>(2)</sup>	165 [2392] 200 [2900] 225 [3262]	Cont Int <sup>(1)</sup> Peak <sup>(2)</sup>	140 [2030] 175 [2540] 225 [3262]	Cont Int <sup>(1)</sup>	240 [176.8] 290 [213.7]	Cont Int <sup>(1)</sup>	60 [15.9] 75 [19.8]	Cont Int <sup>(1)</sup>	465 585	Cont Int <sup>(1)</sup>	10 [13.4] 12 [16.1]
<b>BH 160</b>	165.3 [10.08]	Cont Int <sup>(1)</sup> Peak <sup>(2)</sup>	165 [2392] 200 [2900] 225 [3262]	Cont Int <sup>(1)</sup> Peak <sup>(2)</sup>	140 [2030] 175 [2540] 225 [3262]	Cont Int <sup>(1)</sup>	300 [221.1] 370 [272.6]	Cont Int <sup>(1)</sup>	60 [15.9] 75 [19.8]	Cont Int <sup>(1)</sup>	355 445	Cont Int <sup>(1)</sup>	10 [13.4] 12 [16.1]
<b>BH 200</b>	192.4 [11.73]	Cont Int <sup>(1)</sup> Peak <sup>(2)</sup>	165 [2392] 200 [2900] 225 [3262]	Cont Int <sup>(1)</sup> Peak <sup>(2)</sup>	115 [1670] 160 [2320] 200 [2900]	Cont Int <sup>(1)</sup>	300 [221.1] 390 [287.4]	Cont Int <sup>(1)</sup>	60 [15.9] 75 [19.8]	Cont Int <sup>(1)</sup>	305 380	Cont Int <sup>(1)</sup>	8 [10.7] 15 [20.1]
<b>BH 250</b>	239.1 [14.58]	Cont Int <sup>(1)</sup> Peak <sup>(2)</sup>	165 [2392] 195 [2827] 225 [3262]	Cont Int <sup>(1)</sup> Peak <sup>(2)</sup>	95 [1377] 125 [1810] 180 [2610]	Cont Int <sup>(1)</sup>	300 [221.1] 400 [294.8]	Cont Int <sup>(1)</sup>	60 [15.9] 75 [19.8]	Cont Int <sup>(1)</sup>	245 305	Cont Int <sup>(1)</sup>	6 [8.1] 8 [10.7]
<b>BH 315</b>	286.9 [17.50]	Cont Int <sup>(1)</sup> Peak <sup>(2)</sup>	165 [2392] 195 [2827] 225 [3262]	Cont Int <sup>(1)</sup> Peak <sup>(2)</sup>	80 [1160] 105 [1522] 160 [2320]	Cont Int <sup>(1)</sup>	300 [221.1] 400 [294.8]	Cont Int <sup>(1)</sup>	60 [15.9] 75 [19.8]	Cont Int <sup>(1)</sup>	205 255	Cont Int <sup>(1)</sup>	5 [6.7] 7 [9.4]
<b>BH 400</b>	382.5 [23.33]	Cont Int <sup>(1)</sup> Peak <sup>(2)</sup>	165 [2392] 195 [2827] 225 [3262]	Cont Int <sup>(1)</sup> Peak <sup>(2)</sup>	60 [870] 80 [1160] 130 [1890]	Cont Int <sup>(1)</sup>	300 [221.1] 400 [294.8]	Cont Int <sup>(1)</sup>	60 [15.9] 75 [19.8]	Cont Int <sup>(1)</sup>	150 190	Cont Int <sup>(1)</sup>	4 [5.4] 6 [8.1]

## DATI TECNICI PER MOTORE BH CON ALBERO SE250 / BH MOTOR TECHNICAL DATA WITH SE250 SHAFT

Motore Motor	Cilindrata Displacement	Pressione max ingresso Max. input pressure		Pressione diff. max. Max. differential pressure		Coppia max. Max. torque		Portata max. Max. flow		Velocità max. Max. speed		Potenza max. Max. power	
	cm <sup>3</sup> /rev [in <sup>3</sup> /rev]	bar [psi]		bar [psi]		Nm [lbf-ft]		l/min [U.S. gpm]		giri/min [rpm]		kW [hp]	
<b>BH 050</b>	47.8 [2.91]	Cont Int <sup>(1)</sup> Peak <sup>(2)</sup>	165 [2392] 200 [2900] 225 [3262]	Cont Int <sup>(1)</sup> Peak <sup>(2)</sup>	140 [2030] 175 [2540] 225 [3262]	Cont Int <sup>(1)</sup>	91 [67.1] 115 [84.7]	Cont Int <sup>(1)</sup>	60 [15.9] 75 [19.8]	Cont Int <sup>(1)</sup>	1220 1530	Cont Int <sup>(1)</sup>	10 [13.4] 12 [16.1]
<b>BH 080</b>	71.9 [4.38]	Cont Int <sup>(1)</sup> Peak <sup>(2)</sup>	165 [2392] 200 [2900] 225 [3262]	Cont Int* Peak <sup>(2)</sup>	140 [2030] 175 [2540] 225 [3262]	Cont Int*	135 [99.5] 175 [128.9]	Cont Int <sup>(1)</sup>	60 [15.9] 75 [19.8]	Cont Int <sup>(1)</sup>	820 1025	Cont Int <sup>(1)</sup>	9.5 [12.7] 12 [16.1]
<b>BH 100</b>	100.1 [6.10]	Cont Int <sup>(1)</sup> Peak <sup>(2)</sup>	165 [2392] 200 [2900] 225 [3262]	Cont Int <sup>(1)</sup> Peak <sup>(2)</sup>	140 [2030] 175 [2540] 225 [3262]	Cont Int <sup>(1)</sup>	190 [140] 230 [169.5]	Cont Int <sup>(1)</sup>	60 [15.9] 75 [19.8]	Cont Int <sup>(1)</sup>	590 740	Cont Int <sup>(1)</sup>	10.5 [14] 13 [17.4]
<b>BH 130</b>	127.2 [7.76]	Cont Int <sup>(1)</sup> Peak <sup>(2)</sup>	165 [2392] 200 [2900] 225 [3262]	Cont Int <sup>(1)</sup> Peak <sup>(2)</sup>	140 [2030] 175 [2540] 225 [3262]	Cont Int <sup>(1)</sup>	240 [176.8] 290 [213.7]	Cont Int <sup>(1)</sup>	60 [15.9] 75 [19.8]	Cont Int <sup>(1)</sup>	465 585	Cont Int <sup>(1)</sup>	10 [13.4] 12 [16.1]
<b>BH 160</b>	165.3 [10.08]	Cont Int <sup>(1)</sup> Peak <sup>(2)</sup>	165 [2392] 200 [2900] 225 [3262]	Cont Int <sup>(1)</sup> Peak <sup>(2)</sup>	140 [2030] 175 [2540] 225 [3262]	Cont Int <sup>(1)</sup>	300 [221.1] 370 [272.7]	Cont Int <sup>(1)</sup>	60 [15.9] 75 [19.8]	Cont Int <sup>(1)</sup>	355 445	Cont Int <sup>(1)</sup>	10 [13.4] 12 [16.1]
<b>BH 200</b>	192.4 [11.73]	Cont Int <sup>(1)</sup> Peak <sup>(2)</sup>	165 [2392] 200 [2900] 225 [3262]	Cont Int <sup>(1)</sup> Peak <sup>(2)</sup>	140 [2030] 175 [2540] 225 [3262]	Cont Int <sup>(1)</sup>	360 [265.3] 420 [309.5]	Cont Int <sup>(1)</sup>	60 [15.9] 75 [19.8]	Cont Int <sup>(1)</sup>	305 380	Cont Int <sup>(1)</sup>	10 [13.4] 12 [16.1]
<b>BH 250</b>	239.1 [14.58]	Cont Int <sup>(1)</sup> Peak <sup>(2)</sup>	165 [2392] 195 [2827] 225 [3262]	Cont Int <sup>(1)</sup> Peak <sup>(2)</sup>	110 [1595] 140 [2030] 180 [2610]	Cont Int <sup>(1)</sup>	360 [265.3] 440 [324.2]	Cont Int <sup>(1)</sup>	60 [15.9] 75 [19.8]	Cont Int <sup>(1)</sup>	245 305	Cont Int <sup>(1)</sup>	8 [10.7] 10 [13.4]
<b>BH 315</b>	286.9 [17.50]	Cont Int <sup>(1)</sup> Peak <sup>(2)</sup>	165 [2392] 195 [2827] 225 [3262]	Cont Int <sup>(1)</sup> Peak <sup>(2)</sup>	90 [1310] 120 [1740] 160 [2320]	Cont Int <sup>(1)</sup>	340 [250.6] 440 [324.2]	Cont Int <sup>(1)</sup>	60 [15.9] 75 [19.8]	Cont Int <sup>(1)</sup>	205 255	Cont Int <sup>(1)</sup>	5.6 [7.8] 7.5 [10.1]
<b>BH 400</b>	382.5 [23.33]	Cont Int <sup>(1)</sup> Peak <sup>(2)</sup>	165 [2392] 195 [2827] 225 [3262]	Cont Int <sup>(1)</sup> Peak <sup>(2)</sup>	70 [1020] 95 [1377] 130 [1890]	Cont Int <sup>(1)</sup>	360 [265.3] 460 [339]	Cont Int <sup>(1)</sup>	60 [15.9] 75 [19.8]	Cont Int <sup>(1)</sup>	150 190	Cont Int <sup>(1)</sup>	4.7 [6.3] 6 [8.1]

1) Le condizioni intermittenti non devono durare più del 10% di ogni minuto. Intermittent duty must not exceed 10% every minute.

2) Le condizioni di picco non devono durare più del 1% di ogni minuto. Peak duty must not exceed 1% of every minute.

Pressione massima di scarico senza drenaggio o massima pressione nella linea di drenaggio. I motori sono forniti nella versione con guarnizioni standard (diagramma Standard) o nella versione con guarnizioni ad alta pressione (diagramma HPS).

Per condizioni di pressione e velocità non contemplate dal presente grafico si consiglia di contattare Dana Brevini Fluid Power.

Max. return pressure without drain line or max. pressure in the drain line.

Motor are supplied in standard seal version (Standard chart) or in HPS seal version (HPS chart).

For pressure and speeds not showed in the curve below, please contact Dana Brevini Fluid Power.

### STANDARD (QDR)

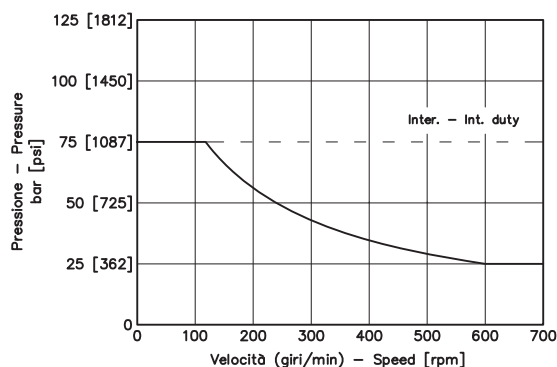

### HPS

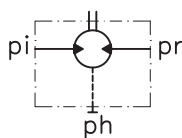
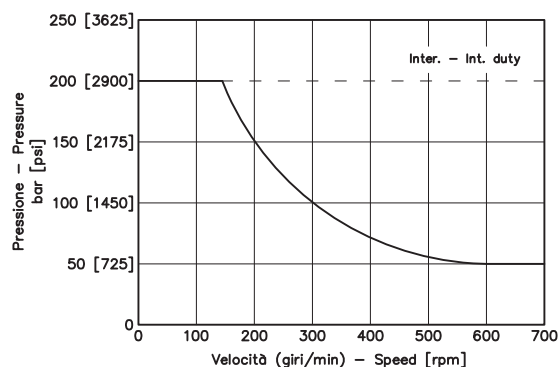

$$Ph = \frac{pi + pr}{2} [bar]$$

ph = pressione in carcassa  
pi = pressione di alimentazione  
pr = pressione di scarico

ph = housing pressure  
pi = inlet pressure  
pr = outlet pressure

- La pressione in carcassa senza drenaggio è data dalla media tra pi e pr.
- Il motore BH è fornito con drenaggio (STANDARD)
- La massima pressione di scarico con drenaggio è di 138 bar Cont.
- The case pressure without drain line is the average between inlet and return pressure.
- As standard, BH motors are supplied with drain port.
- Max. permissible return (back) pressure with drain line 138 bar [2000 psi] Cont.

Le seguenti lettere o numeri del codice, sono state sviluppate per identificare tutte le configurazioni possibili dei motori BH. Usare il seguente modulo per identificare le caratteristiche desiderate. **Tutte le lettere o numeri del codice devono comparire in fase d'ordine.** Si consiglia di leggere attentamente il catalogo prima di iniziare la compilazione del codice di ordinazione.

The following alphanumeric digits system has been developed to identify all of the configuration options for the BH motors. Use the model code below to specify the desired features. **All alphanumeric digits system of the code must be present when ordering.** We recommend to carefully read the catalogue before filling the ordering code.

**CODICE PRODOTTO / MODEL CODE**

1	2	3	4	5	6	7	8	9	10	11	12

**1 - SERIE / SERIES**

BH	Motore orbitale Orbital motor
----	----------------------------------

**2 - CILINDRATA / DISPLACEMENT**

050	50 cm <sup>3</sup> /giro [3.05 in <sup>3</sup> /rev]
080	80 cm <sup>3</sup> /giro [4.88 in <sup>3</sup> /rev]
100	100 cm <sup>3</sup> /giro [6.1 in <sup>3</sup> /rev]
130	130 cm <sup>3</sup> /giro [7.93 in <sup>3</sup> /rev]
160	160 cm <sup>3</sup> /giro [9.76 in <sup>3</sup> /rev]
200	200 cm <sup>3</sup> /giro [12.2 in <sup>3</sup> /rev]
250	250 cm <sup>3</sup> /giro [15.25 in <sup>3</sup> /rev]
315	315 cm <sup>3</sup> /giro [19.21 in <sup>3</sup> /rev]
400	400 cm <sup>3</sup> /giro [24.4 in <sup>3</sup> /rev]

**3 - VERSIONE / VERSION**

S	Versione S S Version	
P	Versione P P Version	Speciale a richiesta Special on request

**4 - FLANGIA / MOUNTING FLANGE**

			VERSIONE / VERSION	
			S	P
6A	Ovale 6 Fori Oval 6 Bolts	STANDARD	•	/
S4	4 fori 3/8 16 UNC - Ø44,45mm 4 Bolt 3/8 16 UNC - Ø1.75 in		•	•
4M	4 fori M10 - Ø44,45mm 4 Bolt M10 - Ø1.75 in		•	/

• Disponibile - Available / Non Disponibile - Not Available

**5 - ESTREMITÀ ALBERO / OUTPUT SHAFT**

			VERSIONE / VERSION	
			S	P
CL254	Albero Cilindrico Ø25.4 mm 1 in Parallel keyed	STANDARD	•	•
CL250	Albero Cilindrico Ø25 mm 0.97 in Parallel keyed		•	•
LC250	Albero Cilindrico Ø25 mm (Chiavetta 7x7x31.5mm) 0.97 in Parallel keyed (7x7x31.5mm [0.275x0.275x1.24in] key)		•	/
CS254	Albero Cilindrico Ø25.4 mm foro spina 1 in Parallel crosshole		•	/
SE250	Albero Scanalato (profilo SAE 6B 1" Z6) Splined Shaft (SAE 6B 1" 6T spline)		•	•
SE210	Albero Scanalato (profilo ANSI-B92.1a-1976-16/32 Z13) Splined Shaft (ANSI-B92.1a-1976-16/32 13T spline)	Speciale a richiesta Special on request	•	•

• Disponibile - Available / Non Disponibile - Not Available



1	2	3	4	5	6	7	8	9	10	11	12

### 6 - ATTACCO / MAIN PORT

			VERSIONE / VERSION	
			S	P
S08	Attacchi 7/8" - 14 UNF SAE10 (no flangia 4M) 7/8" - 14 UNF SAE10 Main Ports (not 4M flange)	STANDARD	•	/
SS8	Attacchi 1/2" - 14 NPTF (no flangia 4M) 1/2" - 14 NPTF Main Ports (not 4M flange)		•	/
MS8	Attacchi G 1/2 BSPP (no flangia 4M) G 1/2 BSPP Main Ports (not 4M flange)		•	/
BFL	Attacchi Manifold (no flangia 4M) Manifold Main Ports (not 4M flange)		•	/
BFM	Attacchi Manifold (ISO) (Solo con flangia 4M) Manifold Main Ports (ISO) (Only with 4M flange)		•	/
F08	Attacchi Frontali 1/2 G BSPP (no flangia 4M) 1/2 G BSPP (End Main Ports) (not 4M flange)		/	•
FS8	Attacchi Frontali 3/4 - 16 UNF (no flangia 4M) 3/4 - 16 UNF (End Main Ports) (not 4M flange)		/	•

• Disponibile - Available / Non Disponibile - Not Available

### 7 - TENUTE / SEALS

N	NBR
---	-----

### 8 - VALVOLA / VALVE

XXXX	Non Richieste Not Required	STANDARD
------	-------------------------------	----------

### 9 - CARATTERISTICA VALVOLA / VALVE FEATURE

000	Caratteristica non necessaria Feature not necessary	STANDARD
-----	--	----------

### 10 - OPZIONE / OPTION

XX	Nessuna Opzione None
----	-------------------------

### 11 - CARATTERISTICA VERSIONE / VERSION FEATURE

		VERSIONE / VERSION	
		S	P
HPS	Guarnizione alta Pressione (senza Drenaggio posteriore) High Pressure Seal (without Rear drain)	•	/
QDR	Versione QUAD-RING con Drenaggio posteriore 1/4 G (BSPP) QUAD-RING Version with Rear drain 1/4 G (BSPP)	•	/
QDS	Versione QUAD-RING con Drenaggio posteriore 7/16" 20UNF2B QUAD-RING Version with Rear drain 7/16" 20UNF2B	•	/
DPS	Guarnizione alta pressione con Drenaggio posteriore 7/16" 20UNF2B High Pressure Seal with Rear drain 7/16" 20UNF2B	•	•
DPM	Guarnizione alta pressione con Drenaggio posteriore 1/4 G (BSPP) High Pressure Seal with Rear drain 1/4 G (BSPP)	•	•

• Disponibile - Available / Non Disponibile - Not Available

### 12 - VERNICIATURA / PAINTING

XX	Non verniciato Not Painted
01	Verniciato Nero RAL 9005 Black Painted RAL 9005

**Flangia S4 Flange**

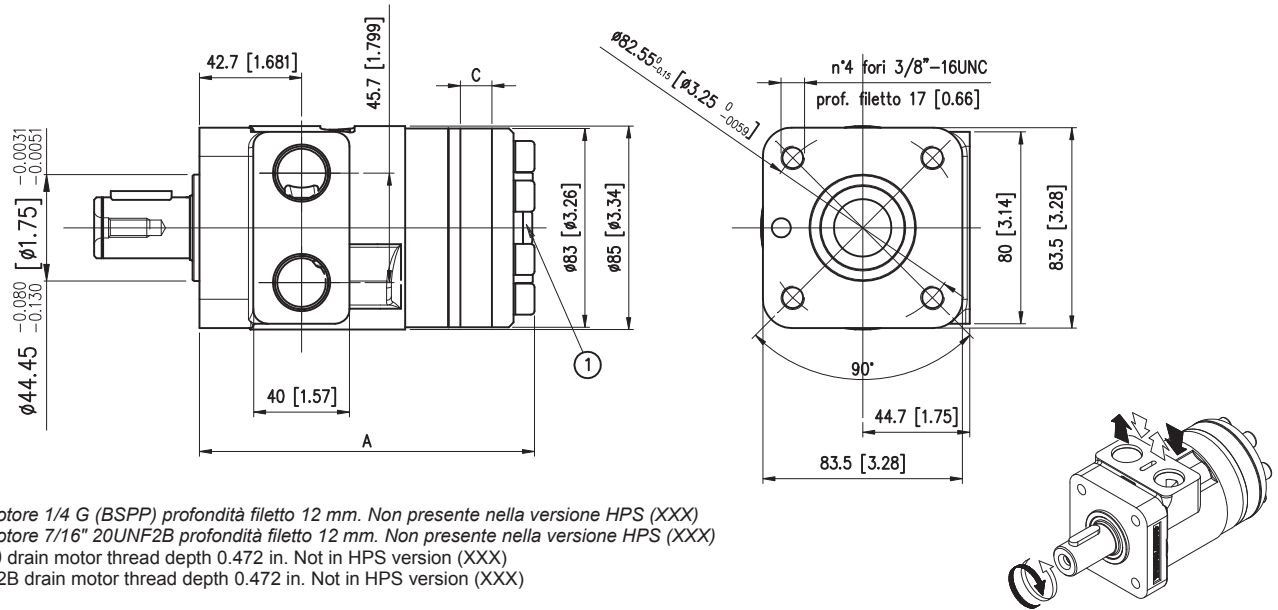

		BH 050	BH 080	BH 100	BH 130	BH 160	BH 200	BH 250	BH 315	BH 400
<b>A</b>	<b>mm [in]</b>	133.1 [5.24]	136.3 [5.36]	140 [5.51]	143.7 [5.65]	148.7 [5.85]	152.2 [5.99]	158.5 [6.24]	164.9 [6.49]	177.6 [6.99]
<b>C</b>	<b>mm [in]</b>	6.3 [0.248]	9.5 [0.374]	13.2 [0.519]	16.9 [0.66]	21.9 [0.86]	25.4 [1.00]	31.7 [1.24]	38.1 [1.50]	50.8 [2.00]
<b>Pesi - Weight</b>	<b>kg [lb]</b>	5.5 [12.12]	5.6 [12.34]	5.8 [12.78]	5.9 [13]	6 [13.4]	6.3 [13.88]	6.5 [14.3]	6.8 [14.98]	7.2 [16]

**Flangia 6A Flange**

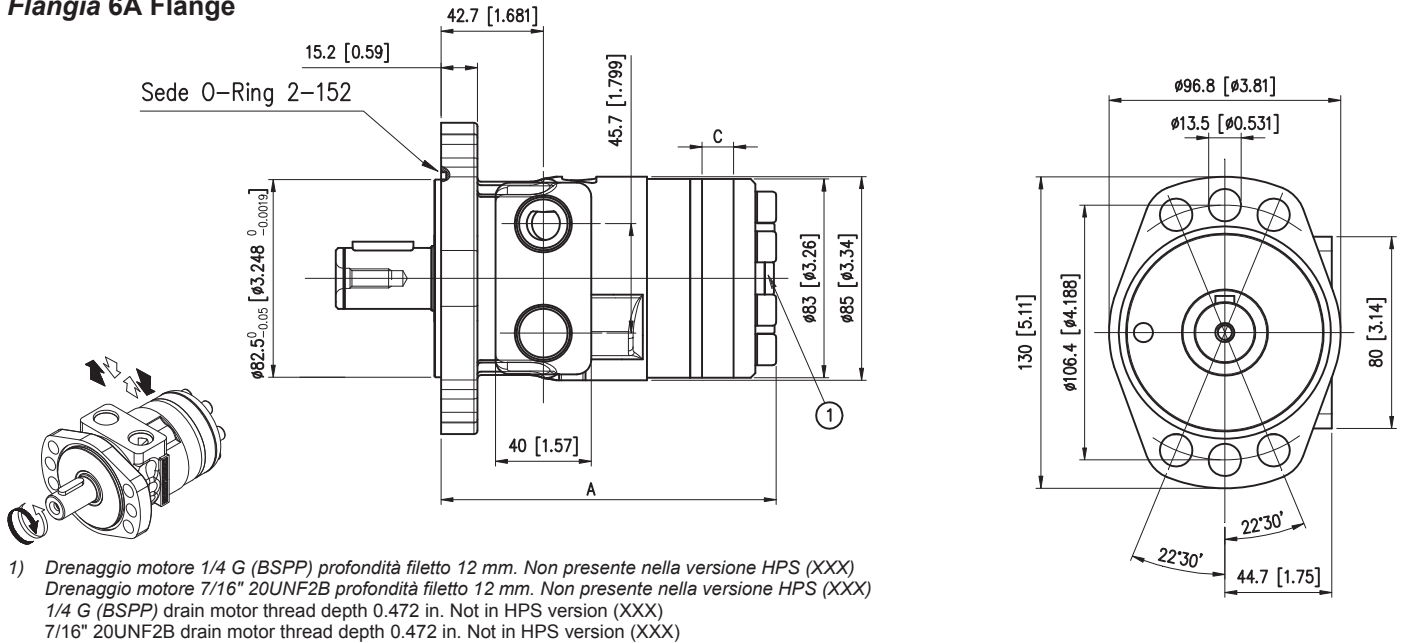

		BH 050	BH 080	BH 100	BH 130	BH 160	BH 200	BH 250	BH 315	BH 400
<b>A</b>	<b>mm [in]</b>	133.1 [5.24]	136.3 [5.36]	140 [5.51]	143.7 [5.65]	148.7 [5.85]	152.2 [5.99]	158.5 [6.24]	164.9 [6.49]	177.6 [6.99]
<b>C</b>	<b>mm [in]</b>	6.3 [0.248]	9.5 [0.374]	13.2 [0.519]	16.9 [0.66]	21.9 [0.86]	25.4 [1.00]	31.7 [1.24]	38.1 [1.50]	50.8 [2.00]
<b>Pesi - Weight</b>	<b>kg [lb]</b>	5.5 [12.12]	5.6 [12.34]	5.8 [12.78]	5.9 [13]	6 [13.4]	6.3 [13.88]	6.5 [14.3]	6.8 [14.98]	7.2 [16]

**Flangia 4M Flange**

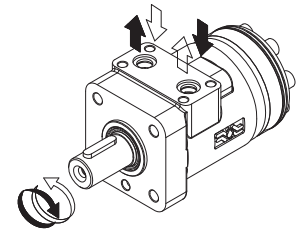
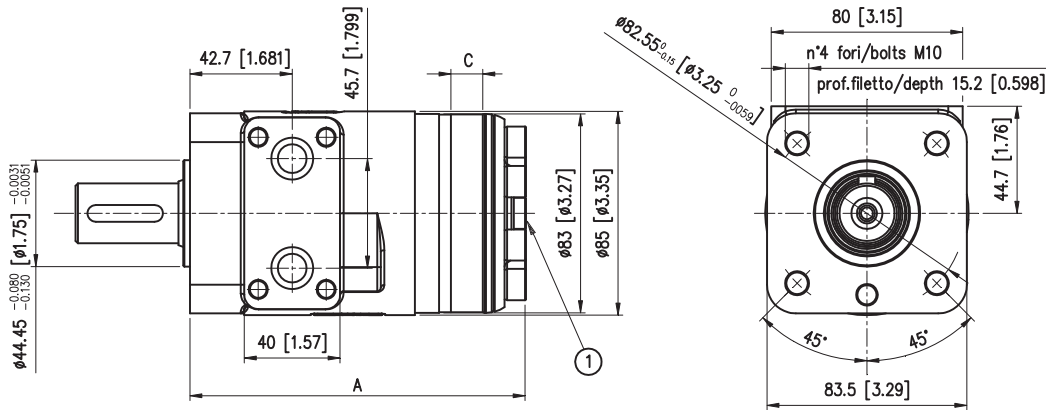

- 1) Drenaggio motore 1/4 G (BSPP) profondità filetto 12 mm. Non presente nella versione HPS (XXX)  
 Drenaggio motore 7/16" 20UNF2B profondità filetto 12 mm. Non presente nella versione HPS (XXX)  
 1/4 G (BSPP) drain motor thread depth 0.472 in. Not in HPS version (XXX)  
 7/16" 20UNF2B drain motor thread depth 0.472 in. Not in HPS version (XXX)

		BH 050	BH 080	BH 100	BH 130	BH 160	BH 200	BH 250	BH 315	BH 400
<b>A</b>	<b>mm [in]</b>	133.45 [5.25]	136.65 [5.38]	140.4 [5.53]	143.9 [5.66]	149.05 [5.87]	152.65 [6]	158.85 [6.25]	165.2 [6.5]	177.9 [7]
<b>C</b>	<b>mm [in]</b>	6.3 [0.248]	9.5 [0.374]	13.2 [0.519]	16.9 [0.66]	21.9 [0.86]	25.4 [1.00]	31.7 [1.24]	38.1 [1.50]	50.8 [2.00]
<b>Pesi - Weight</b>	<b>kg [lb]</b>	5.5 [12.12]	5.6 [12.34]	5.8 [12.78]	5.9 [13]	6 [13.4]	6.3 [13.88]	6.5 [14.3]	6.8 [14.98]	7.2 [16]

**ATTACCHI**  
**OPTIONS**

**BH**

**MS8**

**SS8**

**Manifold (BFL)**

**S08**

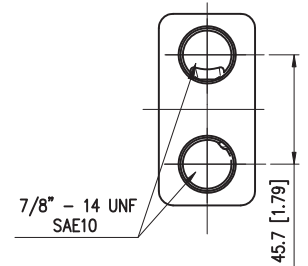
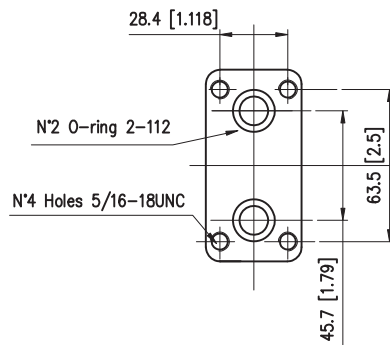
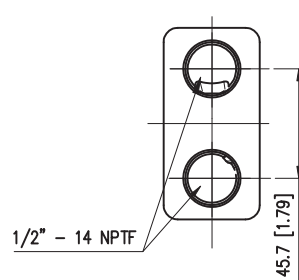
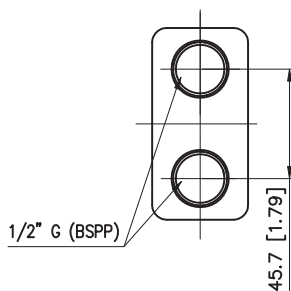

**Manifold (BFM)**

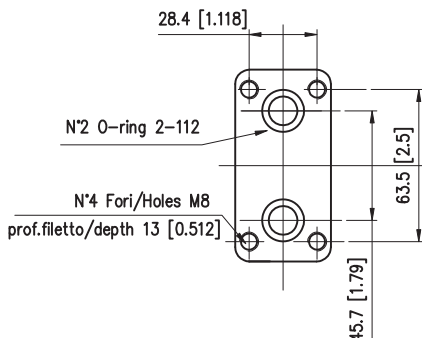

**Flangia S4 Flange**

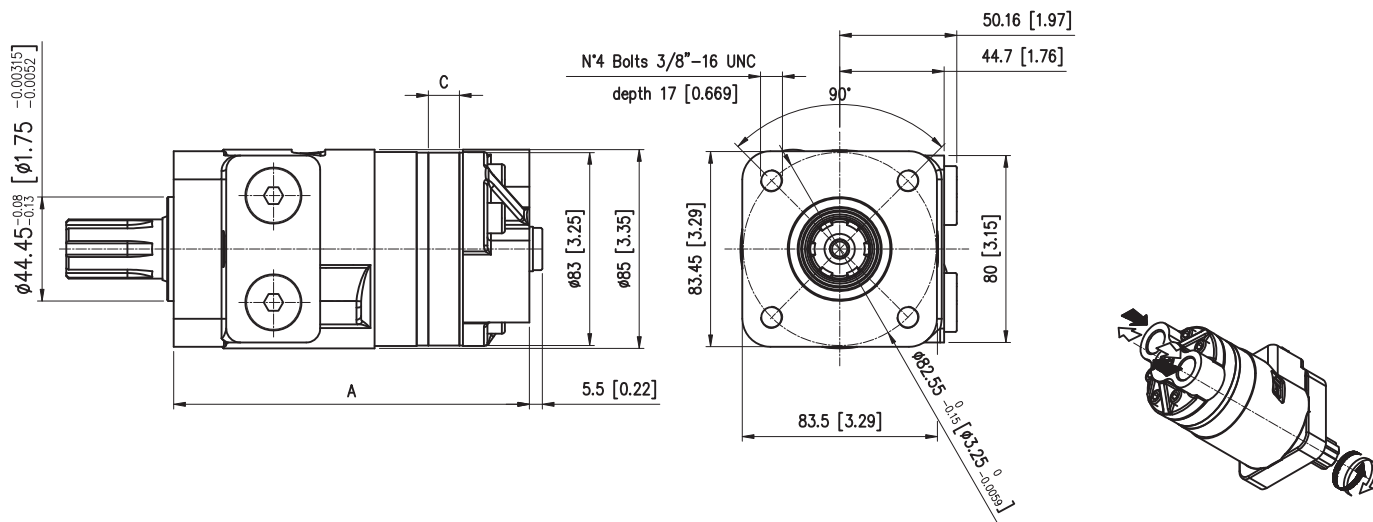

		BH 050	BH 080	BH 100	BH 130	BH 160	BH 200	BH 250	BH 315	BH 400
<b>A</b>	<b>mm [in]</b>	145.5 [5.72]	148.5 [5.84]	152 [5.98]	156 [6.14]	161 [6.33]	164.5 [6.47]	171 [6.73]	177 [6.96]	190 [7.48]
<b>C</b>	<b>mm [in]</b>	6.3 [0.248]	9.5 [0.374]	13.2 [0.519]	16.9 [0.66]	21.9 [0.86]	25.4 [1.00]	31.7 [1.24]	38.1 [1.50]	50.8 [2.00]
<b>Pesi - Weight</b>	<b>kg [lb]</b>	5.8 [12.78]	5.9 [13]	6.1 [13.44]	6.2 [13.66]	6.4 [14.10]	6.6 [14.54]	6.8 [14.98]	7.1 [15.64]	7.6 [16.75]

**OPZIONI ATTACCHI**  
**OPTIONS MAIN PORTS**

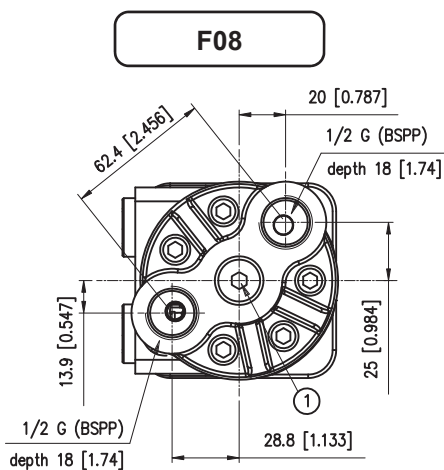

- 1) Drenaggio motore 1/4 G (BSPP) profondità filetto 12 mm.  
1/4 G (BSPP) drain motor thread depth 12 mm [0.472 in].

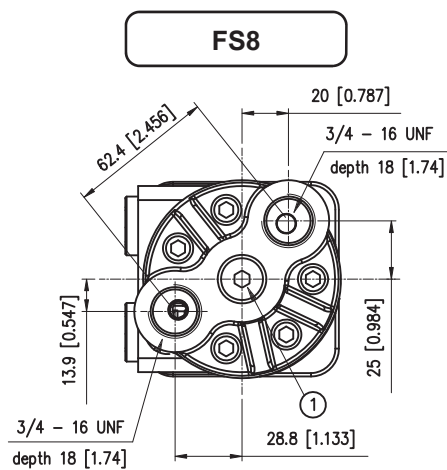

- 1) Drenaggio motore 7/16"-20 UNF profondità filetto 12 mm.  
7/16"-20 UNF drain motor thread depth 12 mm [0.472 in].

**Cilindrico CL254**  
Parallel CL254

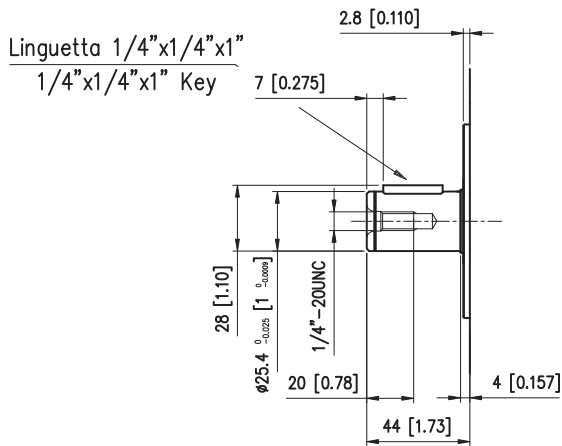

Coppia Massima 300 Nm  
Max Torque Continuous 300 Nm [221.1 lbf-ft]

**Scanalato SE250**  
Splined SE250

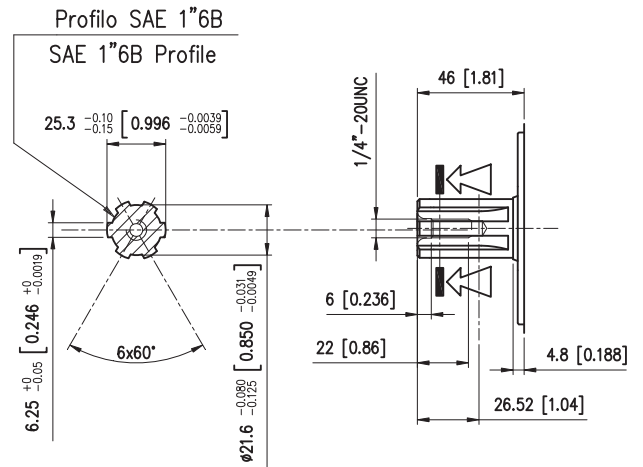

Coppia Massima 360 Nm  
Max Torque Continuous 360 Nm [265.32 lbf-ft]

**Scanalato SE210 (Speciale a richiesta)**  
Splined SE210 (Special on request)

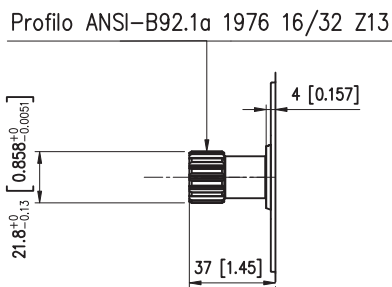

Coppia Massima 140 Nm  
Max Torque Continuous 140 Nm [103.18 lbf-ft]

**Cilindrico CS254**  
Parallel CS254

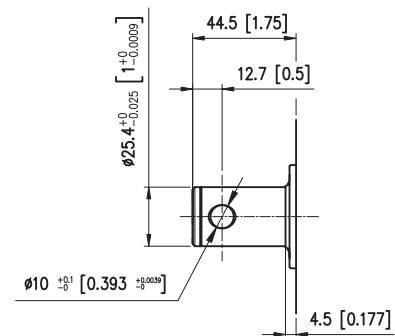

Coppia Massima 300 Nm  
Max Torque Continuous 300 Nm [221.1 lbf-ft]

**Cilindrico CL250**  
Parallel CL250

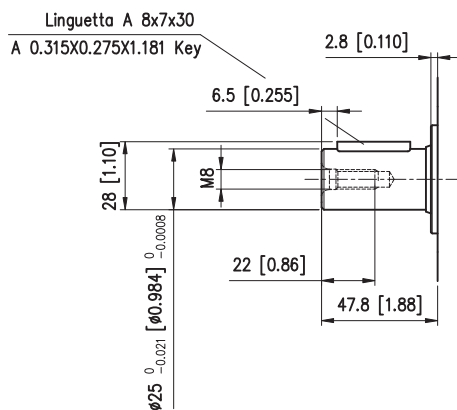

Coppia Massima 300 Nm  
Max Torque Continuous 300 Nm [221.1 lbf-ft]

**Cilindrico LC250**  
Parallel LC250

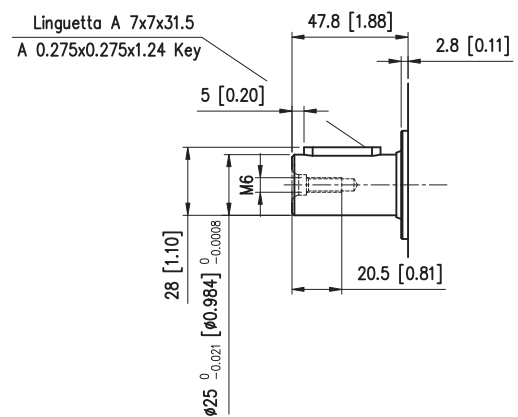

Coppia Massima 300 Nm  
Max Torque Continuous 300 Nm [221.1 lbf-ft]

I carichi ammessi sull'albero variano in funzione di:

- Velocità (n)
- Distanza (L) dal punto di applicazione del carico alla flangia di montaggio
- Versione della flangia di montaggio

Formula utilizzabile per il calcolo del carico radiale (Pr) ai vari numeri di giri (n), e alle varie distanze (L) dalla flangia tipo "6A" ovale 6 fori.

Radial load capacity (Pr) cur ve according to speed (n) and distance (L) from flange, valid for the 6-bolt flange type "6A".

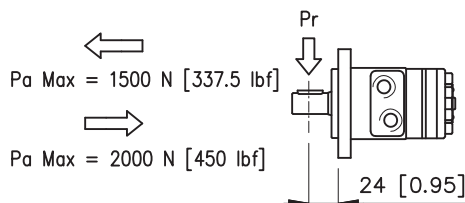

$$Pr = \frac{800}{n} \cdot \frac{242000}{97 + L} \text{ [N]}$$

Formula valida per n >= 200 rpm  
Per n < 200 rpm Pmax = 8000 N

This formula being valid for n >= 200 rpm  
For n < 200 rpm Pmax = 8000 N [1800 lbf]

The permissible radial shaft load depends on

- Speed (n)
- Distance (L) from the point of load to the mounting flange
- Mounting flange version

Formula utilizzabile per il calcolo del carico radiale (Pr) ai vari numeri di giri (n), e alle varie distanze (L) dalla flangia tipo "S4-4M" 4 fori.

Radial load capacity (Pr) cur ve according to speed (n) and distance (L) from flange, valid for the 4-bolt flange type "S4-4M".

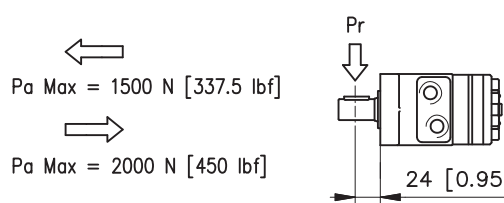

Formula valida per n >= 200 rpm  
Per n < 200 rpm Pmax = 8000 N

This formula being valid for n >= 200 rpm  
For n < 200 rpm Pmax = 8000 N [1800 lbf]

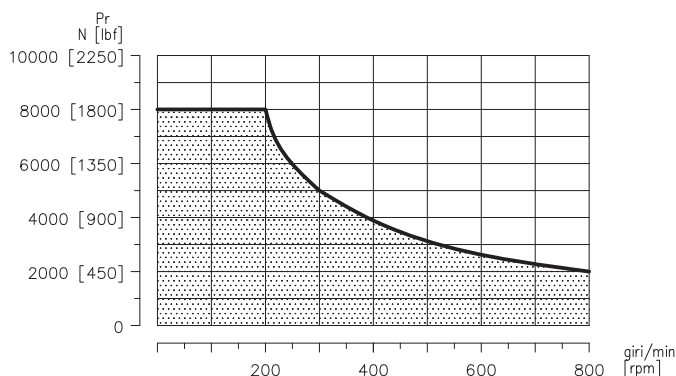

La curva mostra la relazione tra (Pr) e (n) quando:

- L = 24 mm [0.95 in] per motori flangia S4-4M e 6A

The curve shows the relation between (Pr) and (n)

- L = 24 mm [0.95 in] for motors with S4-4M and 6A flange

# BG-BH 050

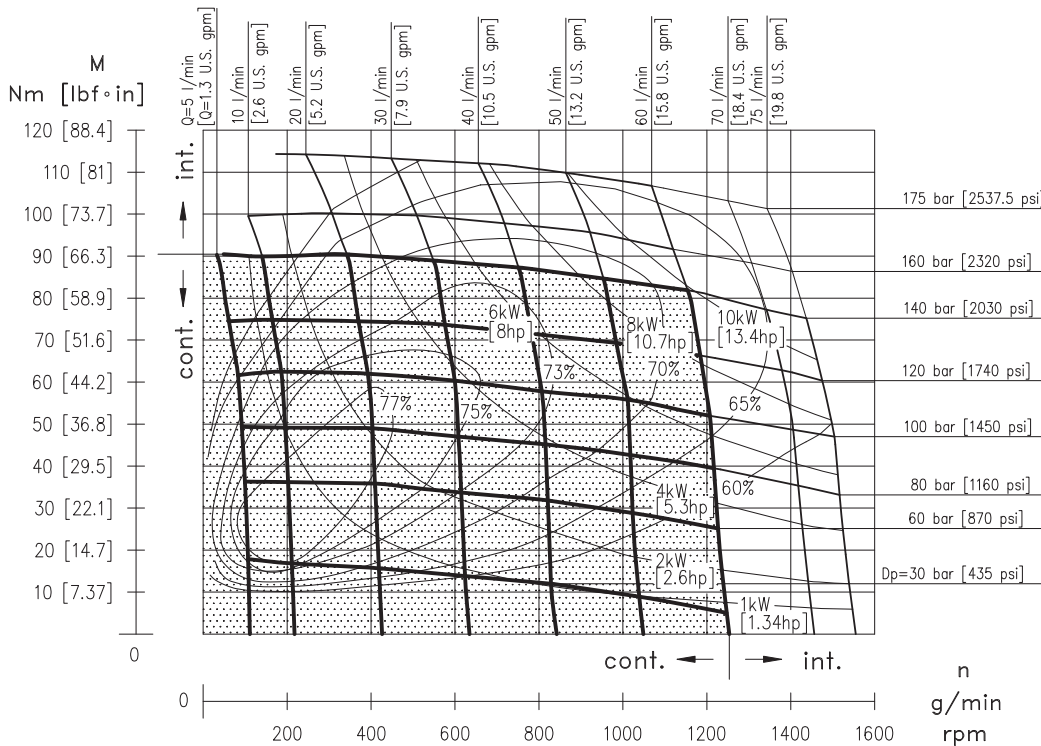

*Pressioni e portate superiori a quelle ammesse in regime continuo non devono essere applicate contemporaneamente. Exceeding continuous pressure values or exceeding flow values indicated, must not occur simultaneously.*

# BG-BH 080

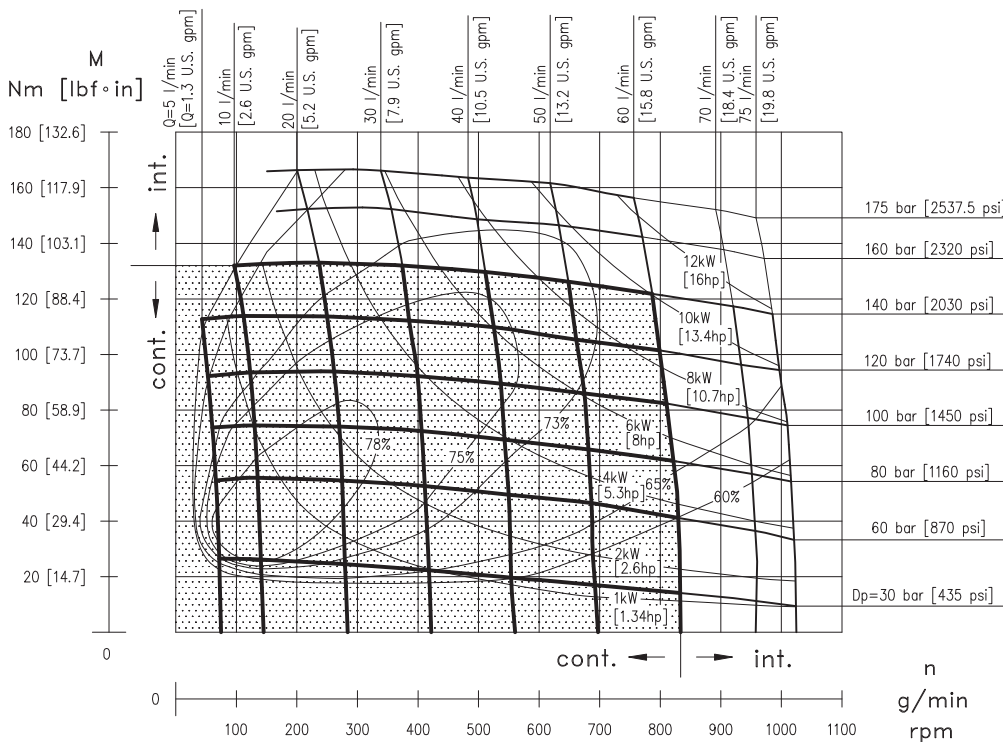

*Pressioni e portate superiori a quelle ammesse in regime continuo non devono essere applicate contemporaneamente. Exceeding continuous pressure values or exceeding flow values indicated, must not occur simultaneously.*



# BG-BH 100

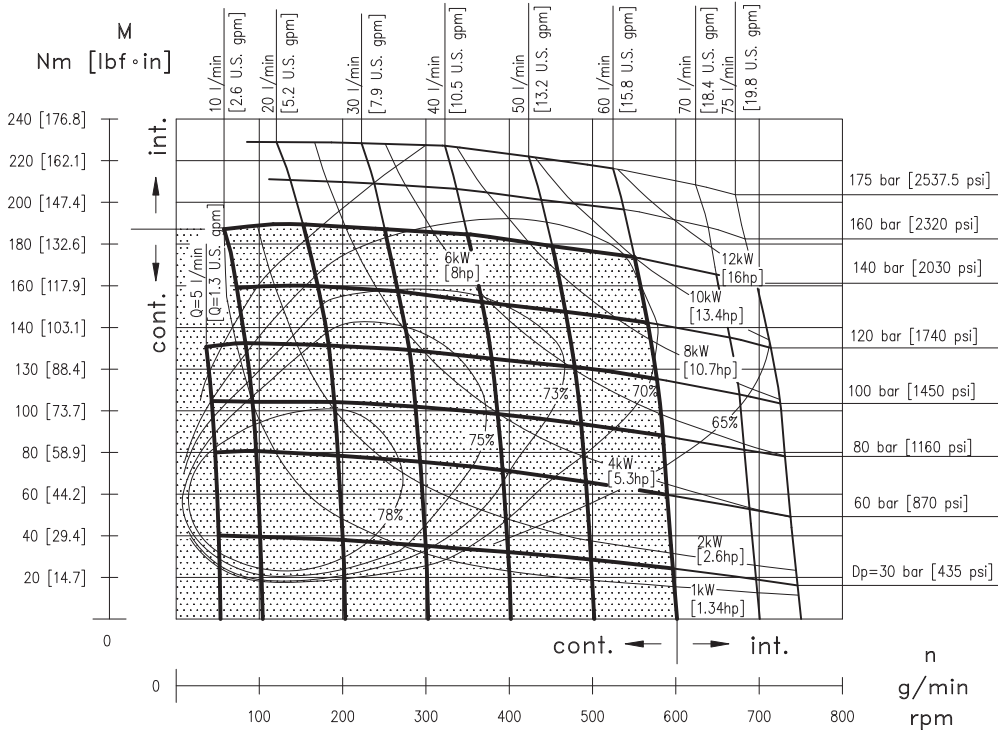

*Pressioni e portate superiori a quelle ammesse in regime continuo non devono essere applicate contemporaneamente.*  
Exceeding continuous pressure values or exceeding flow values indicated, must not occur simultaneously.

# BG-BH 130

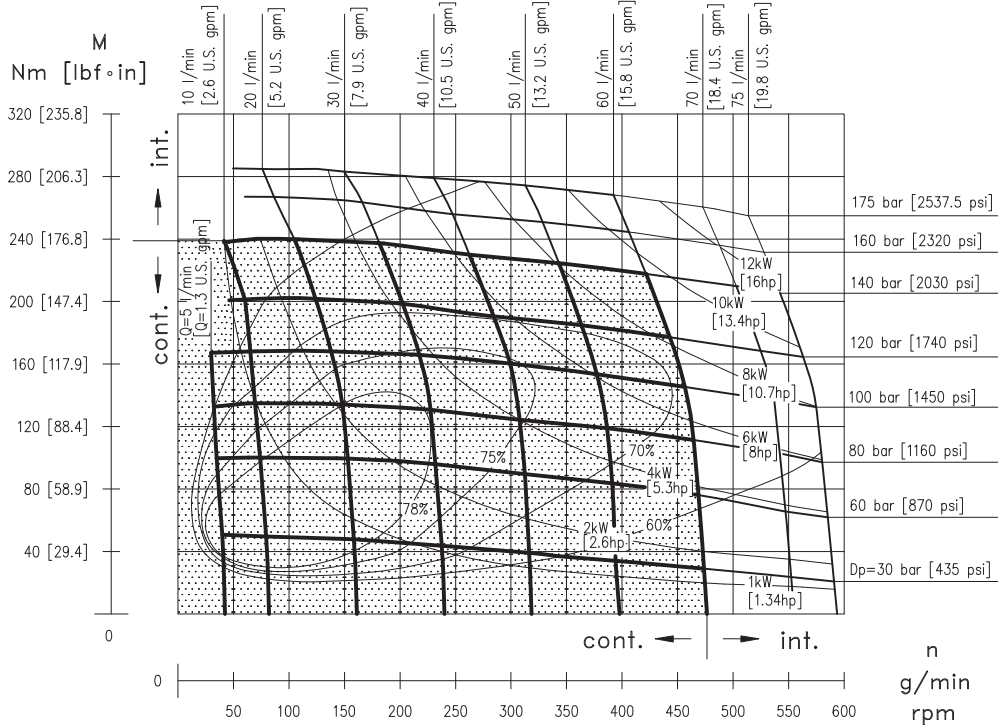

*Pressioni e portate superiori a quelle ammesse in regime continuo non devono essere applicate contemporaneamente.*  
Exceeding continuous pressure values or exceeding flow values indicated, must not occur simultaneously.



# BG-BH 160

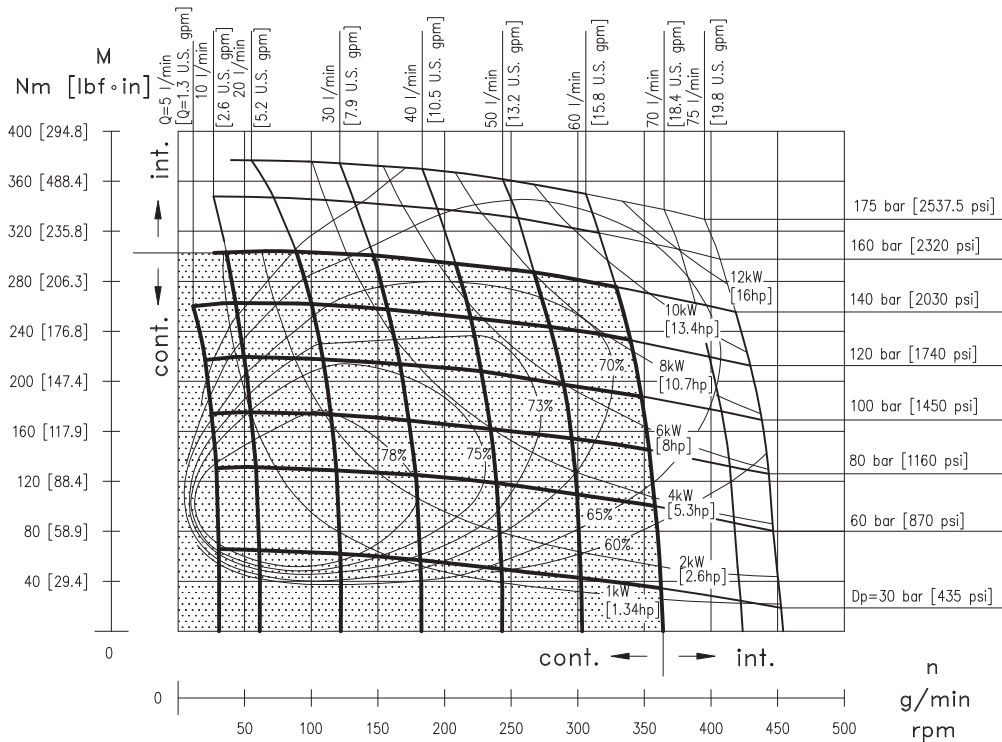

*Pressioni e portate superiori a quelle ammesse in regime continuo non devono essere applicate contemporaneamente. Exceeding continuous pressure values or exceeding flow values indicated, must not occur simultaneously.*

# BG-BH 200

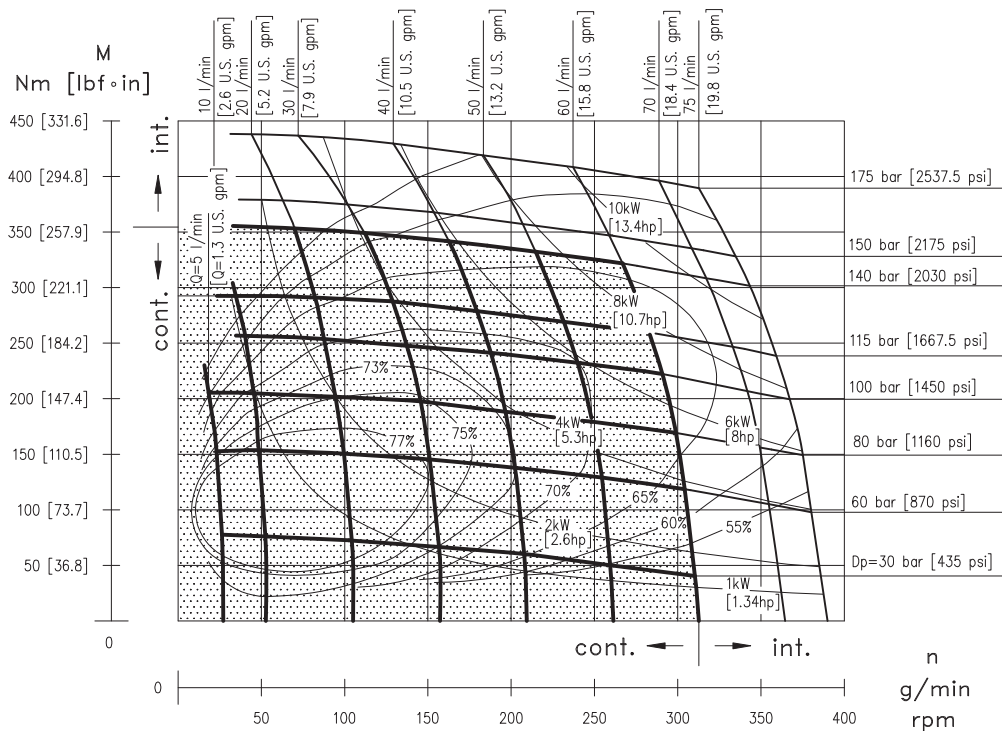

*Pressioni e portate superiori a quelle ammesse in regime continuo non devono essere applicate contemporaneamente. Exceeding continuous pressure values or exceeding flow values indicated, must not occur simultaneously.*

# BG-BH 250

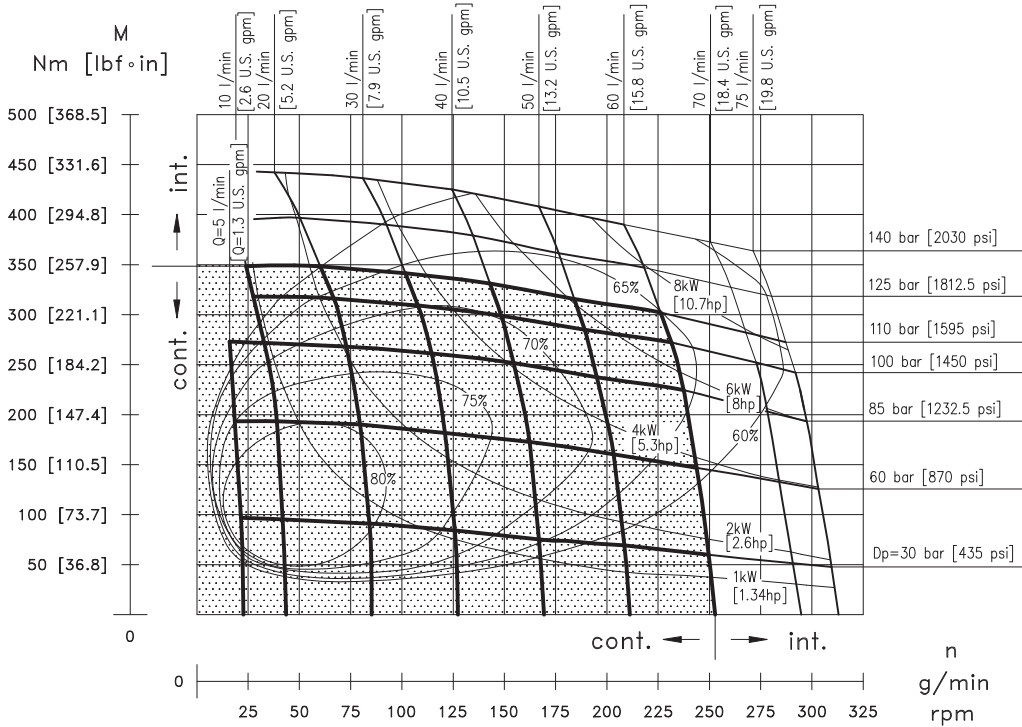

Pressioni e portate superiori a quelle ammesse in regime continuo non devono essere applicate contemporaneamente. Exceeding continuous pressure values or exceeding flow values indicated, must not occur simultaneously.

# BG-BH 315

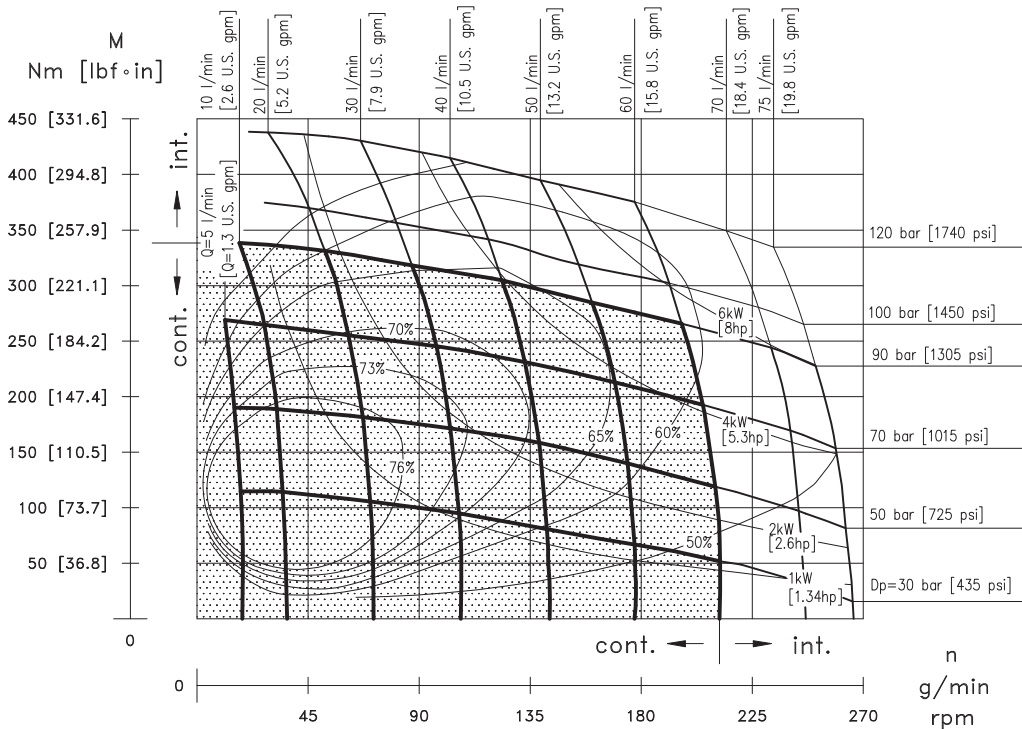

Pressioni e portate superiori a quelle ammesse in regime continuo non devono essere applicate contemporaneamente. Exceeding continuous pressure values or exceeding flow values indicated, must not occur simultaneously.

# BG-BH 400

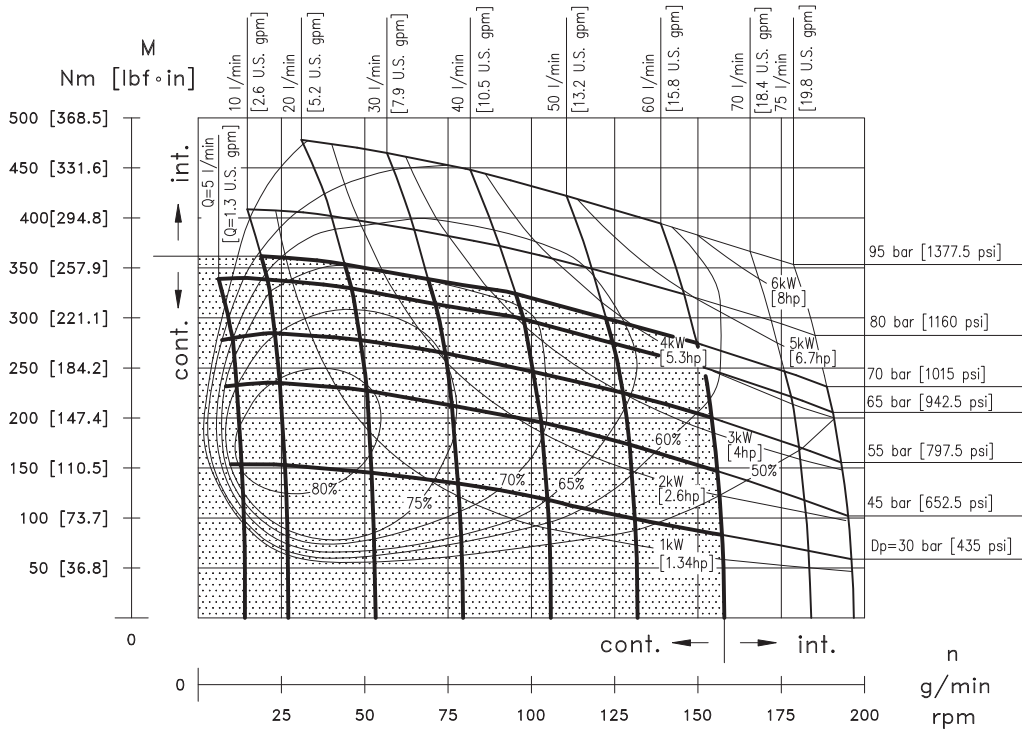

*Pressioni e portate superiori a quelle ammesse in regime continuo non devono essere applicate contemporaneamente.*  
Exceeding continuous pressure values or exceeding flow values indicated, must not occur simultaneously.

**Nota:** I diagrammi sono stati ottenuti con prove eseguite su un numero significativo di motori, utilizzando un olio avente una viscosità cinematica di 37 cSt alla temperatura di 45 C°.

**Note:** Diagrams according to tests done with a relevant number of motors and using hydraulic oil with kinematic viscosity of 37 cSt at 45 C° temperature.





**BREVINI<sup>®</sup>**

*Motion Systems*

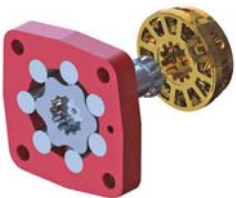
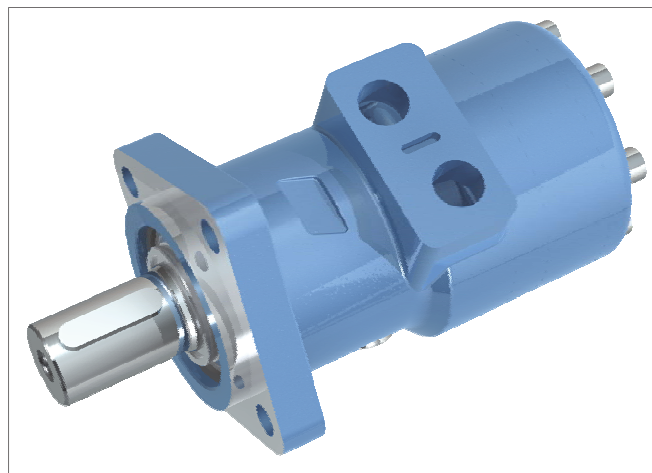

**AR**

***MOTORI ORBITALI***

**ORBITAL MOTORS**

# CARATTERISTICHE DEL MOTORE MOTOR FEATURES

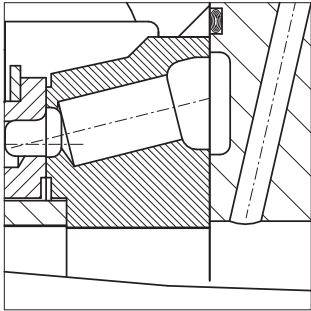

Distribuzione frontale compensata che garantisce minime perdite per trafilamento e recupero dei giochi di usura.

Pressure compensated valve plate maintains minimal leakage and provides compensated wear.

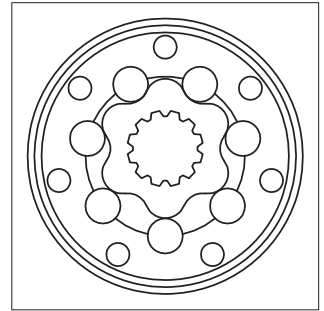
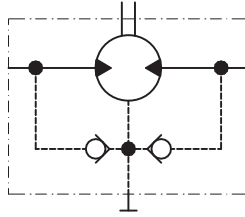

Organo motore roller a 7 camere. 7 sockets - 6 teeth roller set.

Valvole interne di drenaggio per l'utilizzo con pressioni di scarico elevate senza linea di drenaggio collegata.

Built-in check valves to relieve case pressure to the low pressure side of the motor and adequate for application without the need to connect the drain.

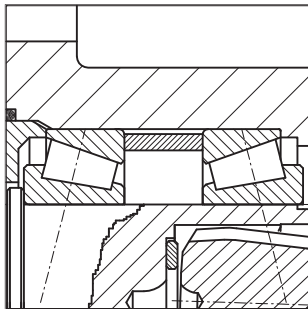

Due opzioni supporto con elevate capacità di carico radiali e assiali.

Two options of bearing for heavy shaft loads.

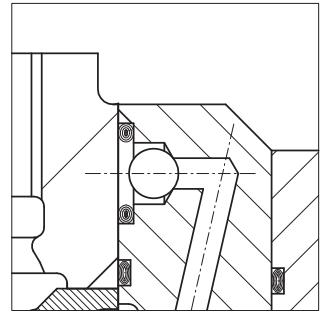
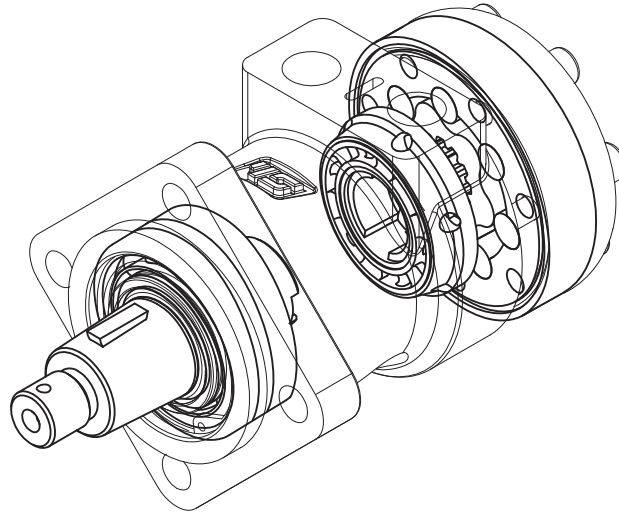

## CODICE DI ORDINAZIONE ORDERING CODE

Serie Series		Cilindrata Displacement		Flangia Mounting		Alberi Shafts		Opzioni Options	
ARS		130		D		C25			
CODICE CODE	Serie Series	CODICE CODE	Cilindrata Displacement	CODICE CODE	Flangia Mounting	CODICE CODE	Alberi Shafts	CODICE CODE	Opzioni Options
ARS	Motore (*) Motor (*)	50	51.6 cm <sup>3</sup> /giro [3.14 in <sup>3</sup> /rev]	N	2 Fori <sup>(4)</sup> 2 Bolts <sup>(4)</sup>	C25	Cilindrico Ø25 mm Parallel keyed 0.984 in		Nessuna opzione Without options
ARSW	Motore (*) Motor (*)	80	80.4 cm <sup>3</sup> /giro [4.9 in <sup>3</sup> /rev]	D	4 Fori <sup>(1)</sup> 4 Bolts <sup>(1)</sup>	C32	Cilindrico Ø32 mm <sup>(1)</sup> Parallel keyed 1.259 in <sup>(1)</sup>	HPS	Guarnizione alta pressione <sup>(5)</sup> High Pressure Seal <sup>(5)</sup>
ARF	Motore (*) Motor (*)	100	100 cm <sup>3</sup> /giro [6.1 in <sup>3</sup> /rev]	DR	2 Fori <sup>(3)</sup> 2 Bolts <sup>(3)</sup>	S32	Scanalato Z14 12/24 DP <sup>(1)</sup> 14T 12/24 DP Spline <sup>(1)</sup>	FP	Freno posteriore <sup>(1)</sup> Brake motor <sup>(1)</sup>
		130	125.7 cm <sup>3</sup> /giro [7.66 in <sup>3</sup> /rev]	DS1	2 Fori <sup>(3)</sup> 2 Bolts <sup>(3)</sup>	SD25	Scanalato 1"6B <sup>(1)</sup> 1"6B Tooth Spline <sup>(1)</sup>	TAC	Attacco contagiri <sup>(2)</sup> Rev-counter connection <sup>(2)</sup>
		160	160 cm <sup>3</sup> /giro [9.76 in <sup>3</sup> /rev]	DS2	2 Fori <sup>(3)</sup> 2 Bolts <sup>(3)</sup>	CN32	Conico <sup>(1)</sup> Tapered <sup>(1)</sup>	TAC-E	Contagiri elettronico <sup>(2)</sup> Electronic tachometer <sup>(2)</sup>
		200	200 cm <sup>3</sup> /giro [12.2 in <sup>3</sup> /rev]					BFL	Base attacco speciale <sup>(3)</sup> Special connection base <sup>(3)</sup>
		250	250 cm <sup>3</sup> /giro [15.2 in <sup>3</sup> /rev]						
		315	314.5 cm <sup>3</sup> /giro [19.1 in <sup>3</sup> /rev]						
		400	393 cm <sup>3</sup> /giro [23.9 in <sup>3</sup> /rev]						

(1) Disponibile con serie ARS e ARSW  
Available with ARS and ARSW series

(2) Non disponibile con serie ARSW  
Not available with ARSW series

(3) Disponibile con serie ARS (Speciale a richiesta)  
Available with ARS series (Special on request)

(4) Disponibile con serie ARF  
Available with ARF series

(5) Disponibile con serie ARS  
Available with ARS series

In caso di caratteristiche non elencate, contattare Uff. Tecnico.  
Please contact technical department for not listed features.

(\*) Il motore è disponibile solo con attacchi BSPP  
The motor is available only with BSPP ports

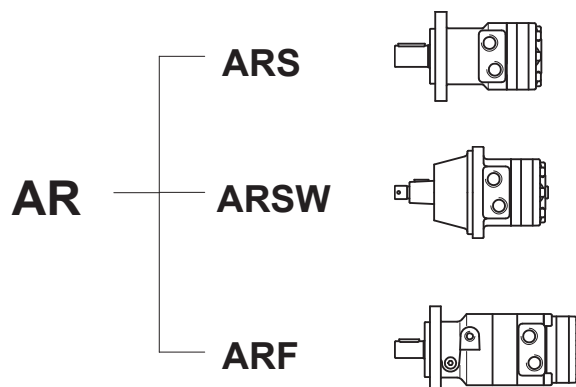

**VERSIONI  
VERSIONS**

**DISPONIBILE SU MOTORI  
AVAILABLE WITH MOTORS**

**HPS**

*Guarnizione alta pressione*  
High Pressure Seal

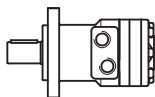

**ARS**

**FP**

*Freno posteriore*  
Brake-motor

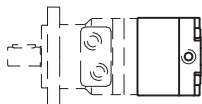

**ARS - ARSW**

**TAC**

*Attacco contagiri*  
Rev-counter connection

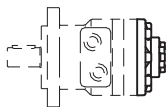

**ARS - ARF**

**TAC-E**

*Contagiri elettronico*  
Electronic tachometer

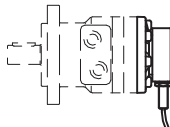

**ARS - ARF**

**BFL**

*Base attacco speciale*  
Special connection base

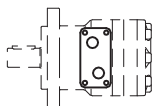

**ARS**

**Speciale a richiesta  
Special on request**

# CARATTERISTICHE TECNICHE TECHNICAL SPECIFICATIONS

Motore Motor	Cilindrata Displacement	Pressione max ingr. Max. input pressure		Pressione diff. max. Max. differential pressure		Coppia max. Max. torque		Portata max. Max. flow		Velocità max. Max. speed		Potenza max. Max. power	
	cm <sup>3</sup> /rev [in <sup>3</sup> /rev]	bar [psi]		bar [psi]		Nm [lbf-ft]		l/min [U.S. gpm]		giri/min [rpm]		kW [hp]	
AR 50	51.6 [3.14]	Cont	175 [2538]	Cont	160 [2320]	Cont	118 [86.9]	Cont	40 [11]	Cont	775	Cont	8.5 [11.3]
		Int*	190 [2755]	Int*	190 [2755]	Int*	136 [100.2]	Int*	50 [13]	Int*	970	Int*	10.2 [13.6]
		Peak**	250 [3625]	Peak**	250 [3625]								
AR 80	80.4 [4.9]	Cont	175 [2538]	Cont	160 [2320]	Cont	184 [135.6]	Cont	60 [16]	Cont	746	Cont	12.6 [16.8]
		Int*	190 [2755]	Int*	190 [2755]	Int*	210 [154.7]	Int*	75 [20]	Int*	933	Int*	15.2 [20.3]
		Peak**	250 [3625]	Peak**	250 [3625]								
AR 100	100 [6.1]	Cont	175 [2538]	Cont	160 [2320]	Cont	230 [169.5]	Cont	60 [16]	Cont	600	Cont	13 [17.4]
		Int*	190 [2755]	Int*	190 [2755]	Int*	260 [191.6]	Int*	75 [20]	Int*	750	Int*	15.5 [20.7]
		Peak**	250 [3625]	Peak**	250 [3625]								
AR 130	125.7 [7.66]	Cont	175 [2538]	Cont	150 [2175]	Cont	270 [198.9]	Cont	60 [16]	Cont	477	Cont	12 [16]
		Int*	190 [2755]	Int*	190 [2755]	Int*	330 [243.2]	Int*	75 [20]	Int*	597	Int*	14.2 [19]
		Peak**	250 [3625]	Peak**	250 [3625]								
AR 160	160 [9.76]	Cont	175 [2538]	Cont	150 [2175]	Cont	340 [250.5]	Cont	60 [16]	Cont	375	Cont	12.4 [16.6]
		Int*	190 [2755]	Int*	190 [2755]	Int*	420 [309.5]	Int*	75 [20]	Int*	470	Int*	15.7 [21]
		Peak**	250 [3625]	Peak**	250 [3625]								
AR 200	200 [12.2]	Cont	175 [2538]	Cont	125 [1813]	Cont	350 [257.9]	Cont	65 [17]	Cont	325	Cont	10.8 [14.4]
		Int*	190 [2755]	Int*	175 [2538]	Int*	480 [353.7]	Int*	75 [20]	Int*	375	Int*	15.5 [20.7]
		Peak**	250 [3625]	Peak**	230 [3335]								
AR 250	250 [15.2]	Cont	175 [2538]	Cont	110 [1595]	Cont	380 [280]	Cont	65 [17]	Cont	260	Cont	9.8 [13.1]
		Int*	190 [2755]	Int*	155 [2248]	Int*	520 [383.2]	Int*	80 [21]	Int*	320	Int*	13.4 [17.9]
		Peak**	250 [3625]	Peak**	200 [2900]								
AR 315	314.5 [19.1]	Cont	175 [2538]	Cont	80 [1160]	Cont	340 [250.5]	Cont	65 [17]	Cont	207	Cont	6.1 [8.1]
		Int*	190 [2755]	Int*	120 [1740]	Int*	510 [375.8]	Int*	80 [21]	Int*	254	Int*	8.5 [11.3]
		Peak**	250 [3625]	Peak**	150 [2175]								
AR 400	393 [23.9]	Cont	175 [2538]	Cont	65 [943]	Cont	358 [263.8]	Cont	65 [17]	Cont	165	Cont	4.7 [6.2]
		Int*	190 [2755]	Int*	100 [1450]	Int*	510 [375.8]	Int*	80 [21]	Int*	203	Int*	6 [8]
		Peak**	250 [3625]	Peak**	120 [1740]								

Prove eseguite con olio 37 cSt a 45°C. / Test conditions: 37 cSt oil at 45°C.

Motore Motor	Cilindrata - Displacement																									
	50		80		100		130		160		200		250		315		400									
Velocità Speed (rpm)	0	100	>	0	100	>	0	100	>	0	100	>	0	100	>	0	100	>	0	100	>					
	100	300	300	100	300	300	100	300	300	100	300	300	100	300	300	100	300	300	100	300	300					
Press.max scarico cont senza drenaggio (bar) Max cont. Return pressure without drain line (bar)	ARS	75	50	25	75	50	25	75	50	25	75	50	25	75	50	25	75	50	25	75	50	-	75	50	-	
	ARSW	75	50	25	75	50	25	75	50	25	75	50	25	75	50	25	75	50	25	75	50	-	75	50	-	
	ARF	20			20			20			20			20			20			20			20			20
Conversioni Conversions:	../FP****	-			-			-			-			-			-			-			-			
	TAC	20			20			20			20			20			20			20			20			20
	TAC-E***	20			20			20			20			20			20			20			20			20
Press.max scarico con drenaggio bar[psi] Max return pressure with drain line bar [psi]				140 [2030]			140 [2030]			140 [2030]			140 [2030]			140 [2030]			140 [2030]			140 [2030]			140 [2030]	
Coppia min di spunto a press diff. max Min starting torque N [lbf]	Cont.	62 [46]			120 [88]			150 [111]			187 [138]			242 [178]			282 [208]			310 [228]			269 [198]			286 [211]
	Int.*	70 [51.6]			139 [102]			172 [127]			230 [170]			294 [217]			390 [287]			415 [306]			397 [293]			413 [304]

\* Le condizioni intermittenti non devono durare più del 10% di ogni minuto. / Intermittent duty must not exceed 10% each minute.

\*\* Le condizioni di picco non devono durare più dell'1% di ogni minuto. / Peak duty must not exceed 1% each minute.

\*\*\* Le condizioni di contropressione devono essere le più basse fra il motore e la versione. / The back up pressure must be lower between the motor and the motor version considered.

\*\*\*\* È indispensabile l'utilizzo del drenaggio per lo smaltimento del calore. / In order to eliminate overheating it is necessary to use the drain port.



## MASSIMA PRESSIONE AMMESSA SULLA GUARNIZIONE ALBERO MAX PERMISSIBLE SHAFT SEAL PRESSURE

I motori ARS sono forniti nella versione con guarnizioni standard (diagramma Standard) o nella versione con guarnizioni ad alta pressione (diagramma HPS). Per condizioni di pressione e velocità non contemplate dal presente grafico si consiglia di contattare Dana Brevini.

N.B.: Sulle versioni con Tachimetro e Freno non è possibile installare guarnizioni HPS.

ARS Motor are supplied in standard seal version (Standard chart) or in HPS seal version (HPS chart). For pressure and speeds not showed in the curve below, please contact Dana Brevini.

N.B.: Tachometer and Brake versions is not available with HPS seals.

STANDARD

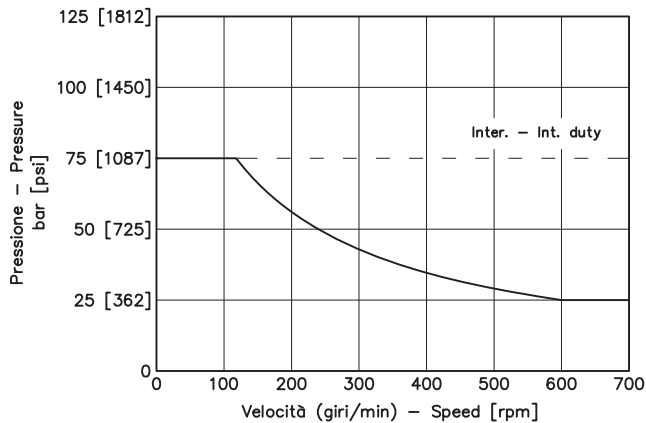

HPS

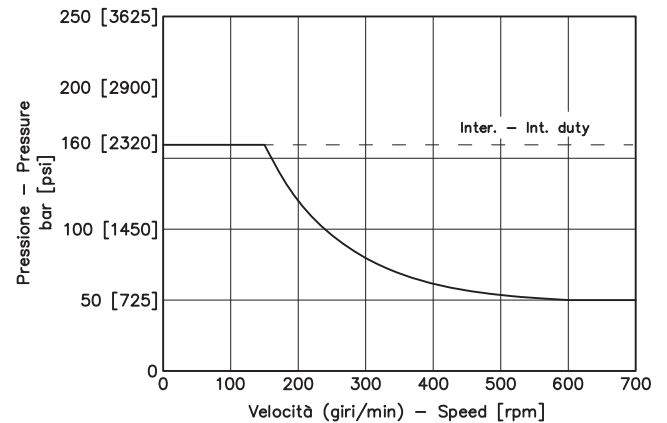

## PERDITE DI CARICO PER ATTRAVERSAMENTO PRESSURE LOSS

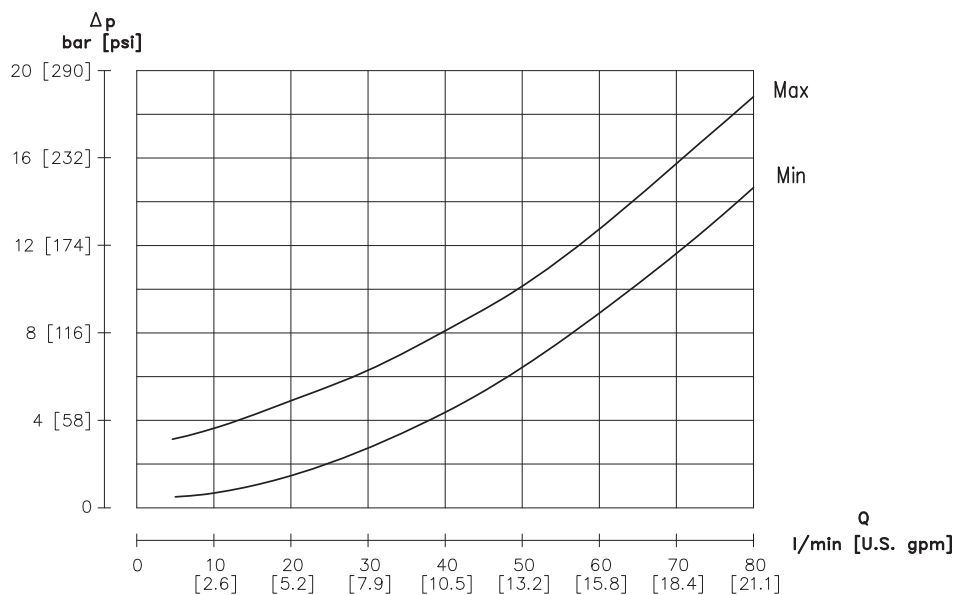

Tendenzialmente i motori con bassa cilindrata si posizionano verso la curva MAX, viceversa i motori con alta cilindrata si posizionano verso la curva MIN.

Low displacement motors have the tendency to operate near the "Max" curve, while high displacement ones have the opposite tendency.

Linguetta A 10x8x40 DIN 6885  
A 10x8x40 DIN 6885 key

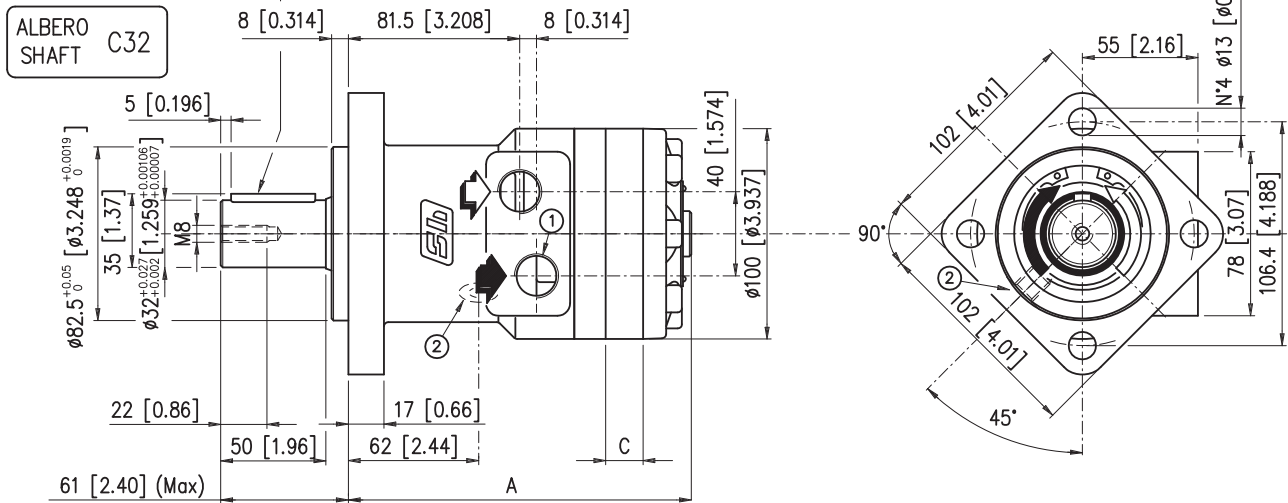

ANS B92.1 1970 Flat root side fit D.P. Z14 12/24  
Angolo di pressione - Pressure angle 30°

- 1) N° 2 fori di alimentazione 1/2 G (BSPP) profondità filetto 18mm  
No. 2 1/2 G (BSPP) main ports thread depth 0.70 in
- 2) Drenaggio motore 1/4 G (BSPP) profondità filetto 12mm  
1/4 G (BSPP) drain motor thread depth 0.472 in

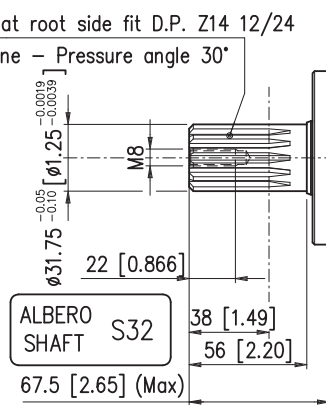

Linguetta A 8x7x30 DIN 6885  
A 8x7x30 DIN 6885 key

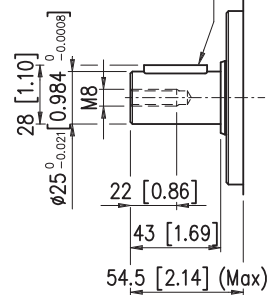

Linguetta 6x9 UNI 6606-69  
6x9 UNI 6606-69 key

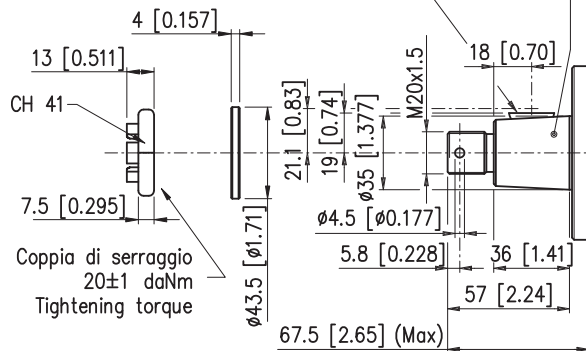

Profilo SAE 1"6B  
SAE 1"6B Profile

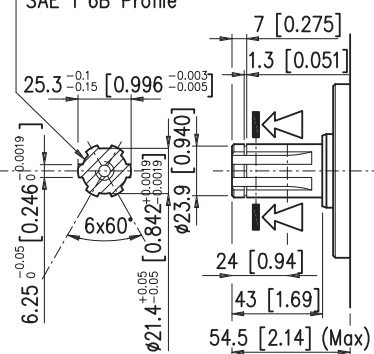

		ARS 50	ARS 80	ARS 100	ARS 130	ARS 160	ARS 200	ARS 250	ARS 315	ARS 400
<b>A</b>	<b>mm [in]</b>	152.5 [6.00]	157.5 [6.20]	160.9 [6.33]	165.3 [6.50]	171.3 [6.74]	178.3 [7.01]	187 [7.36]	198.3 [7.80]	211.8 [8.33]
<b>C</b>	<b>mm [in]</b>	9 [0.354]	14 [0.551]	17.4 [0.68]	21.8 [0.85]	27.8 [1.09]	34.8 [1.37]	43.5 [1.71]	54.8 [2.15]	68.38 [2.69]
<b>Pesi - Weight</b>	<b>kg [lb]</b>	7.5 [16.5]	7.7 [16.9]	7.9 [17.4]	8.2 [18]	8.4 [18.5]	8.8 [19.3]	9.2 [20.2]	9.7 [21.3]	10.4 [22.9]

Linguetta A 10x8x40 DIN 6885

A 10x8x40 DIN 6885 key

ALBERO SHAFT C32

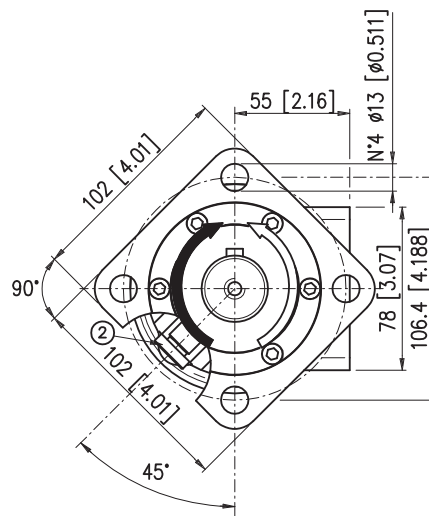
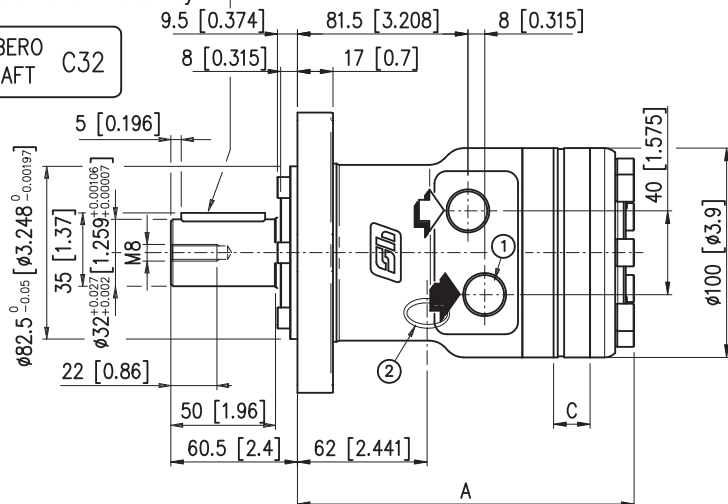

Linguetta A 8x7x30 DIN 6885

A 8x7x30 DIN 6885 key

ALBERO SHAFT C25

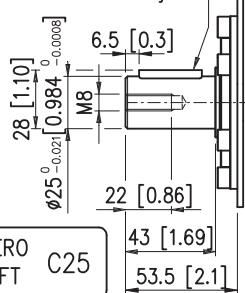

ANS B92.1 1970 Flat root side fit D.P. Z14 12/24

Angolo di pressione - Pressure angle 30°

ALBERO SHAFT S32

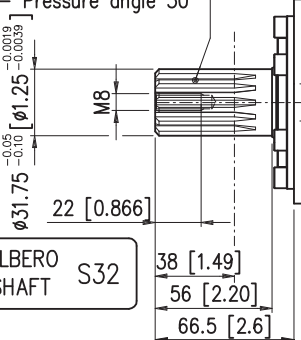

Profilo SAE 1"6B

SAE 1"6B Profile

ALBERO SHAFT SD25

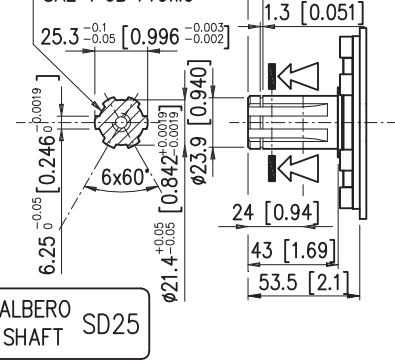

Linguetta 6x9 UNI 6606-69

6x9 UNI 6606-69 key

Conicità' 1:10  
1:10 taper

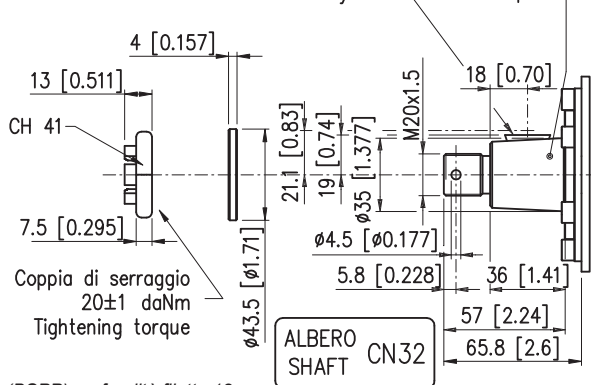

Linguetta 5/16"x5/16"x1"1/4 UNI 6604

5/16"x5/16"x1"1/4 UNI 6604 key

ALBERO SHAFT C31.75

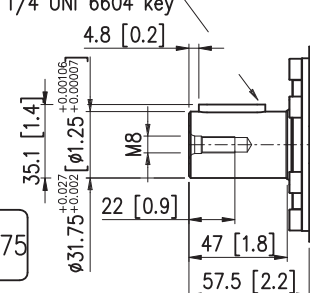

- 1) N° 2 fori di alimentazione 1/2 G (BSPP) profondità filetto 18mm  
No. 2 1/2 G (BSPP) main ports thread depth 0.70 in
- 2) Drenaggio motore 1/4 G (BSPP) profondità filetto 12mm  
1/4 G (BSPP) drain motor thread depth 0.472 in

		ARS 50	ARS 80	ARS 100	ARS 130	ARS 160	ARS 200	ARS 250	ARS 315	ARS 400
<b>A</b>	<b>mm [in]</b>	152 [5.98]	157 [6.18]	161 [6.34]	165 [6.50]	171 [6.73]	178 [7.01]	187 [7.36]	198 [7.79]	212 [8.35]
<b>C</b>	<b>mm [in]</b>	9 [0.354]	14 [0.551]	17.4 [0.68]	21.8 [0.85]	27.8 [1.09]	34.8 [1.37]	43.5 [1.71]	54.8 [2.15]	68.38 [2.69]
<b>Pesi - Weight</b>	<b>kg [lb]</b>	7.5 [16.5]	7.7 [16.9]	7.9 [17.4]	8.2 [18]	8.4 [18.5]	8.8 [19.3]	9.2 [20.2]	9.7 [21.3]	10.4 [22.9]

**FLANGIA TIPO "DR" (QUADRATA, 4 FORI FILETTATI)**  
**"DR" TYPE FLANGE (SQUARE, 4 THREADED BOLTS)**

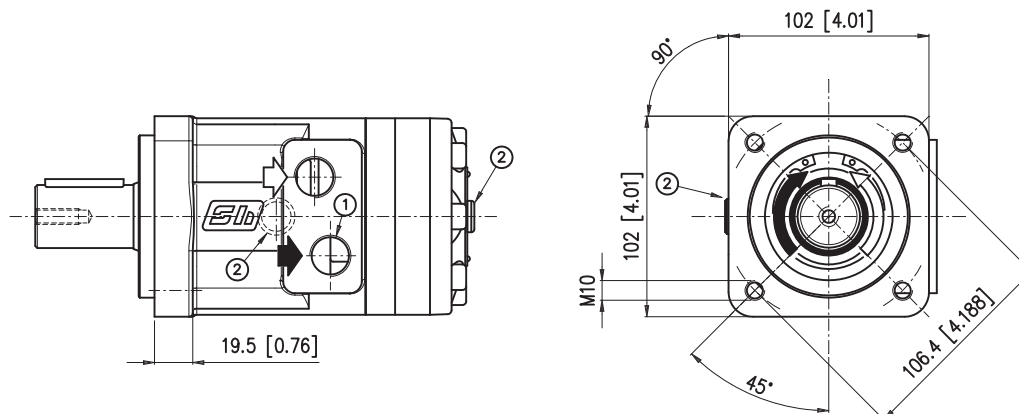

Per le dimensioni non indicate fare riferimento al disegno del motore ARS flangia "D". Non disponibile in versione HPS  
Refer to ARS "D" flange drawing for any dimension here not indicated. Not available in HPS version

**FLANGIA TIPO "DS1" (2 FORI)**  
**"DS1" TYPE FLANGE (2 BOLTS)**

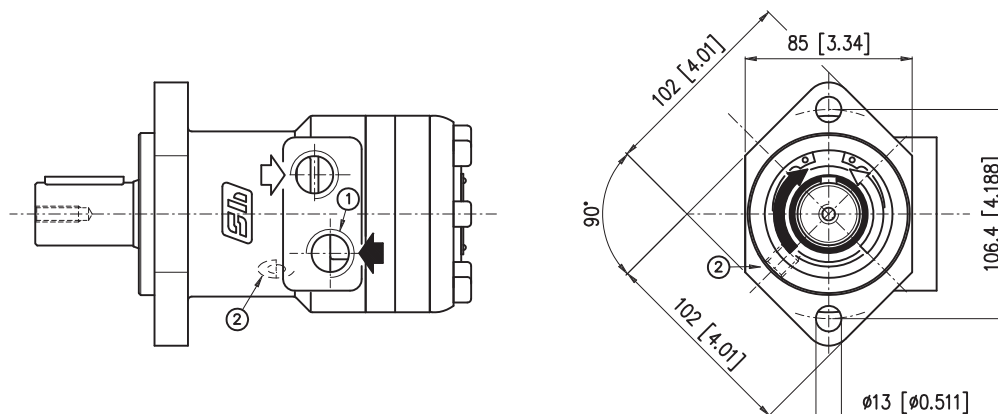

Per le dimensioni non indicate fare riferimento al disegno del motore ARS flangia "D". Non disponibile in versione HPS  
Refer to ARS "D" flange drawing for any dimension here not indicated. Not available in HPS version

**FLANGIA TIPO "DS2" (2 FORI)**  
**"DS2" TYPE FLANGE (2 BOLTS)**

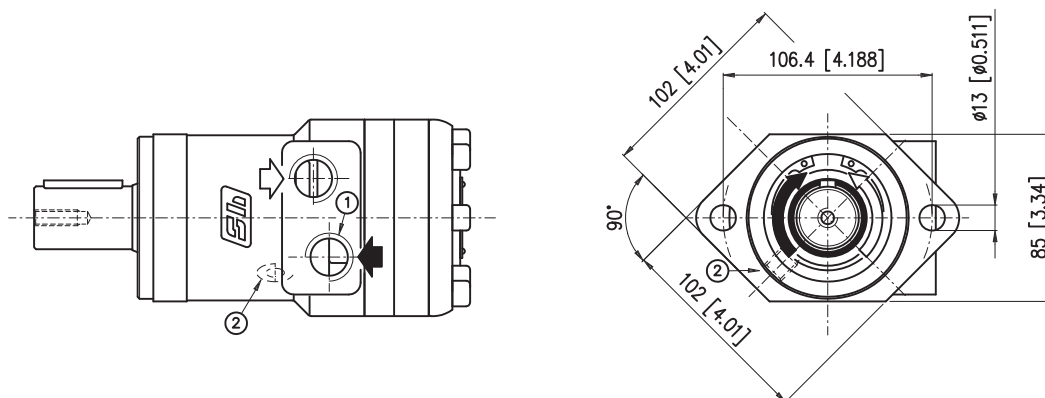

Per le dimensioni non indicate fare riferimento al disegno del motore ARS flangia "D". Non disponibile in versione HPS  
Refer to ARS "D" flange drawing for any dimension here not indicated. Not available in HPS version

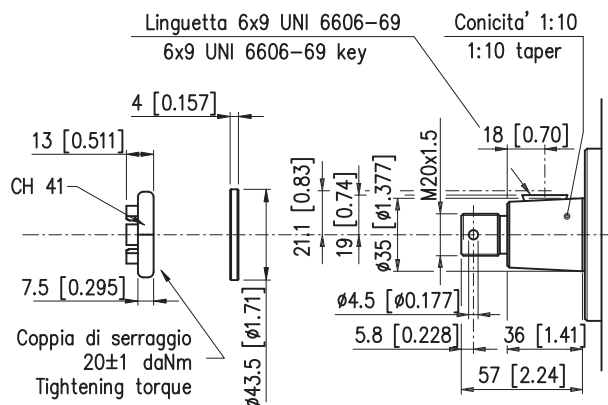
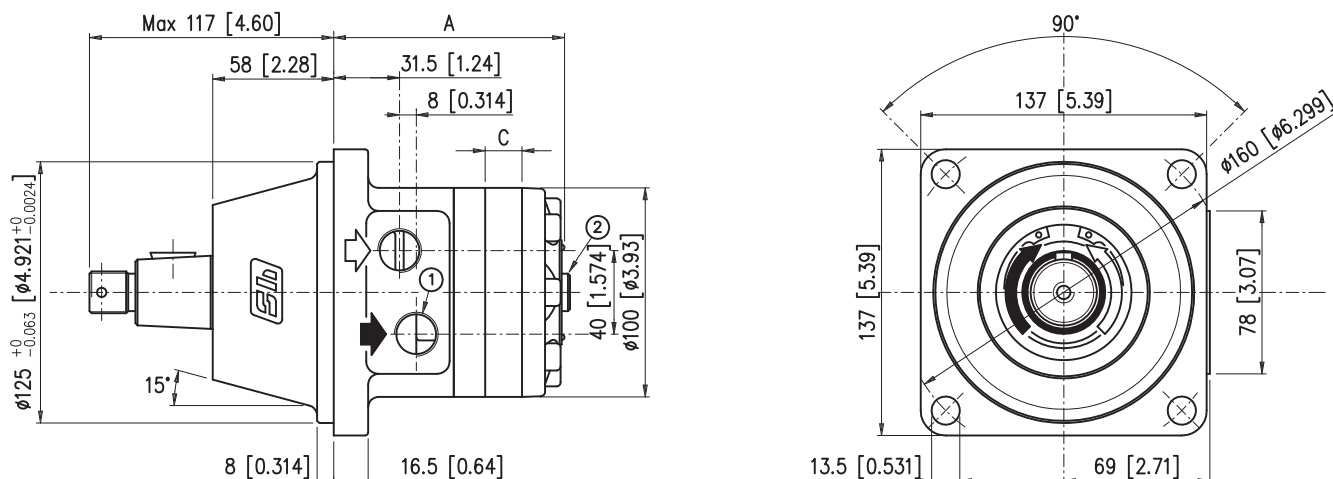

ALBERO  
SHAFT CN32

- 1) N° 2 fori di alimentazione 1/2 G (BSPP) profondità filetto 18mm  
No. 2 1/2 G (BSPP) main ports thread depth 0.70 in
- 2) Drenaggio motore 1/4 G (BSPP) profondità filetto 12mm  
1/4 G (BSPP) drain motor thread depth 0.472 in

**Sono disponibili a richiesta anche i seguenti alberi: C32 - C25 - SD25 - S32**  
**The following shafts are available upon request : C32 - C25 - SD25 - S32**

		ARSW 50	ARSW 80	ARSW 100	ARSW 130	ARSW 160	ARSW 200	ARSW 250	ARSW 315	ARSW 400
<b>A</b>	<b>mm [in]</b>	102.5 [4.03]	107.5 [4.23]	110.9 [4.36]	115.3 [4.53]	121.3 [4.77]	128.3 [5.05]	137 [5.39]	148.3 [5.83]	161.8 [6.37]
<b>C</b>	<b>mm [in]</b>	9 [0.354]	14 [0.551]	17.4 [0.68]	21.8 [0.85]	27.8 [1.09]	34.8 [1.37]	43.5 [1.71]	54.8 [2.15]	68.38 [2.69]
<b>Pesi - Weight</b>	<b>kg [lb]</b>	9.8 [21.5]	10.1 [22.2]	10.3 [22.7]	10.5 [23.1]	10.8 [23.8]	11.2 [24.6]	16.1 [35.4]	12.1 [26.6]	12.8 [28.2]

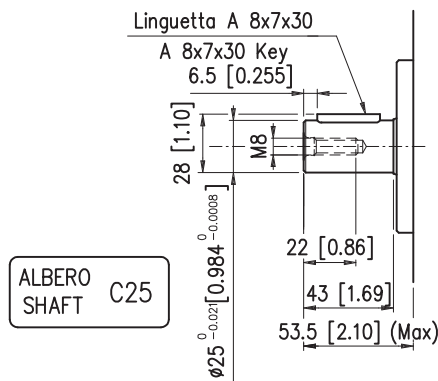
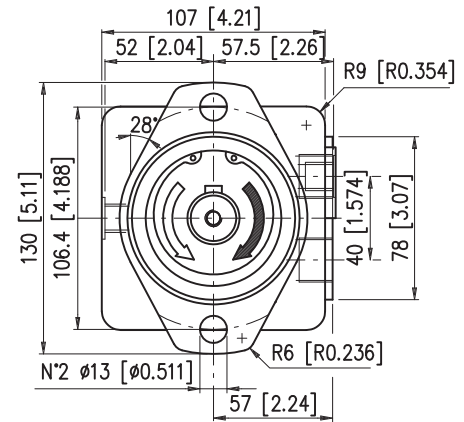
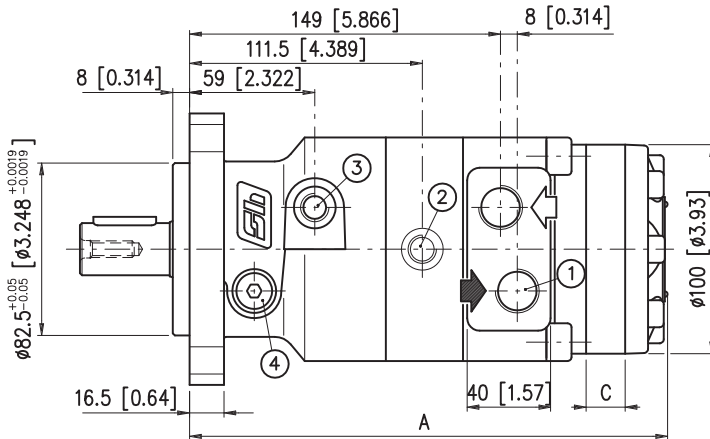

- 1) N° 2 fori di alimentazione 1/2 G (BSPP) profondità filetto 18mm  
No. 2 1/2 G (BSPP) main ports thread depth 0.70 in
- 2) Drenaggio motore 1/4 G (BSPP) profondità filetto 13mm  
1/4 G (BSPP) drain motor thread depth 0.511 in
- 3) Foro comando apertura freno 1/4 G (BSPP) profondità filetto 13mm  
Brake releasing plug 1/4 G (BSPP) thread depth 0.511 in
- 4) N°2 tappi carico-scarico olio freno 1/4 G (BSPP) profondità filetto 13mm  
N°2 brake filling and drain plugs 1/4 G (BSPP) thread depth 0.511 in

		ARF 50	ARF 80	ARF 100	ARF 130	ARF 160	ARF 200	ARF 250	ARF 315	ARF 400
<b>A</b>	<b>mm [in]</b>	220 [8.66]	225 [8.85]	228.4 [8.99]	232.8 [9.16]	238.8 [9.40]	245.8 [9.67]	254.5 [10.01]	265.8 [10.46]	279.3 [10.99]
<b>C</b>	<b>mm [in]</b>	9 [0.354]	14 [0.551]	17.4 [0.68]	21.8 [0.85]	27.8 [1.09]	34.8 [1.37]	43.5 [1.71]	54.8 [2.15]	68.38 [2.69]
<b>Pesi - Weight</b>	<b>kg [lb]</b>	13.5 [29.7]	13.8 [30.4]	14.1 [31]	14.3 [31.5]	14.6 [32.1]	15.1 [33.2]	15.8 [34.8]	16.3 [35.9]	16.9 [37.2]

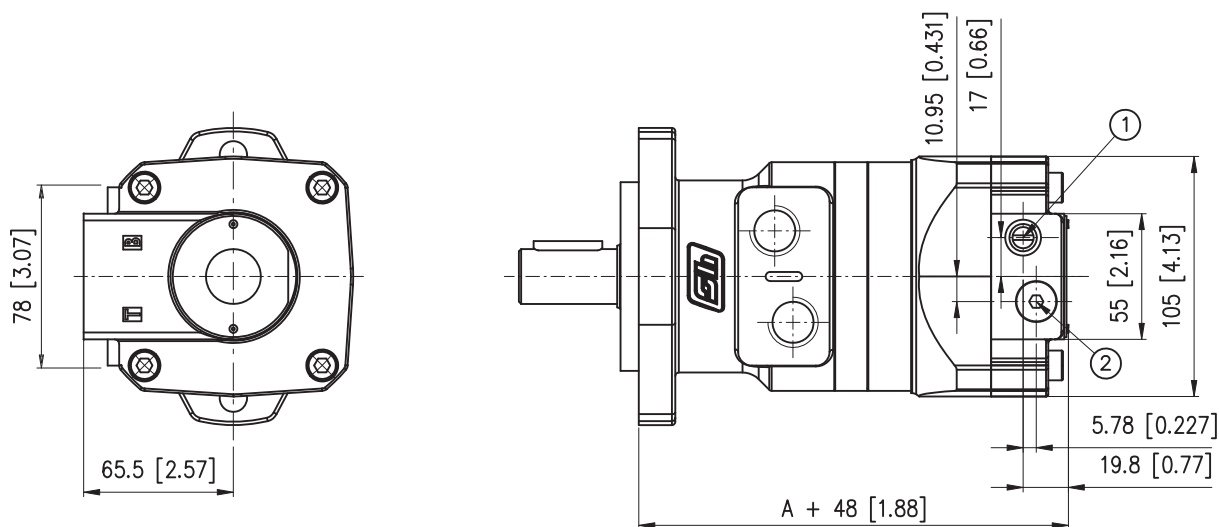

**Freno disponibile sui motori: ARS - ARSW**  
**Brake available on following engines: ARS - ARSW**

**La quota "A" è riferita al dimensionale del motore senza freno FP**  
**"A" Dimension is related to motor length without FP brake**

- 1) **Comando apertura freno 1/4 G (BSPP) profondità filetto 13mm**  
**1/4 G (BSPP) brake releasing port; thread depth 0.511 in**
- 2) **Drenaggio Motore 1/4 G (BSPP) profondità filetto 13mm**  
**1/4 G (BSPP) drain port thread depth 0.511 in**

## CARATTERISTICHE FRENI BRAKE FEATURES

I freni integrati dei motori ARF e FP sono a dischi multipli negativi ad apertura idraulica.

Questi freni agiscono sotto la spinta di una serie di molle su coppie di dischi alternati fissi e mobili; lo sbloccaggio avviene per effetto della pressione idraulica nel pistone. Questo tipo di funzionamento, chiamato "Negativo", è idoneo per impieghi come freno di stazionamento o di sicurezza, quindi in presenza di una frenatura statica e non per frenatura dinamica, funzione che deve essere svolta dal sistema idraulico. Nel caso di utilizzo dinamico del freno, da noi sconsigliato, è necessario contattare l'ufficio tecnico Dana Brevini. Le alte velocità di rotazione, specie per i freni FP, oppure prolungati funzionamenti con asse verticale, possono generare elevati aumenti di temperatura e quindi mal funzionamento del freno; consigliamo di contattare l'ufficio tecnico Dana Brevini.

The ARF and FP motors have a multi-plate disc brake built in, which is hydraulically released.

This mechanical type brake has springs that push together the plates, which are mounted side by side, so that a static braking action is obtained. Whenever an hydraulic pressure acts on the piston, the brake is released. The so called "negative brake" is suitable for duties like parking or safety brakes and/or whenever a static braking action is required. A dynamic braking action must be obtained using the hydraulic circuit. If a motor is to be used for dynamic braking (which is unadvisable) please contact Dana Brevini Engineering Service first. High rotation speed and/or vertical position use of the motor might cause discs to overheat, particularly in FP brakes, and consequential malfunctioning. In this case, please contact Dana Brevini Engineering Service.

<b>Caratteristiche del freno:</b>	<b>ARF (*)</b>	<b>Brake features:</b>
Pressione di apertura minima	22 bar [319 psi]	Mimumum releare pressure
Pressione di freno libero	27 bar [391.5 psi]	Complete brake release press.
Pressione massima	200 bar [2900 psi]	Max. pressure
Coppia massima statica	350 Nm [257.9 lbf·ft]	Max static torque

(\*) :

La camera del freno nella versione ARF é separata dal drenaggio del motore e richiede 80 cm<sup>3</sup> di olio idraulico.  
The ARF motor has a separate brake chamber which must be filled with 80 cm<sup>3</sup> of hydraulic oil.

<b>Caratteristiche del freno:</b>	<b>FP</b>	<b>Brake features:</b>
Pressione di apertura minima	22 bar [319 psi]	Mimumum releare pressure
Pressione di freno libero	25 bar [362.5 psi]	Complete brake release press.
Pressione massima	160 bar [2320 psi]	Max. pressure
Coppia massima statica	370 Nm [272.6 lbf·ft]	Max static torque
Velocità massima motore	350 rpm	Max motor speed

### Accorgimenti per l'installazione

- Il motore idraulico con freno posteriore FP richiede obbligatoriamente il collegamento del drenaggio motore, posto sul corpo freno, in serbatoio a scarico libero. Mediante tale accorgimento si smaltisce il calore generato dall'attrito del freno.

- Nel caso di motori del tipo ARF si consiglia l'utilizzo per l'impianto frenante di oli resistenti al calore e all'invecchiamento, con viscosità ISO VG 32 e indice di viscosità pari o superiore a 95.

- Nel caso di funzionamento in circuito aperto è consigliato l'utilizzo di una valvola di ritardo chiusura freno, per evitare il funzionamento dinamico dello stesso.

Nella pagina successiva sono riportati alcuni schemi di applicazioni più usuali.

### Installation layout

- The FP hydraulic motors must always have the drain port (on casing) directly connected with tank. This improves oil cooling, which is important to avoid brake overheating.

- It is advisable to use heat and wear resistant hydraulic oils in ARF type motors: viscosity grade ISO VG 32; viscosity index <sup>3</sup> 95

- If open circuit layout is needed, it is advisable to use a flow control valve on brake piston ports, in order to avoid dynamic braking.

Common application layouts on following page.



**CIRCUITO APERTO, UN MOTORE FRENO, ROTAZIONE IN ENTRAMBE LE DIREZIONI ED AZIONAMENTO FRENO AUTOMATICO.**

Questa è la tipica configurazione di un sistema di rotazione (gru, escavatori, piattaforme mobili, falconi, etc.). Quando la pompa invia olio al motore la pressione aziona la valvola di commutazione che, attivando la linea del freno, ne consente il rilascio. La valvola doppia overcentre rallenta la massa in rotazione fino quasi all'arresto quando entra in azione il freno statico.

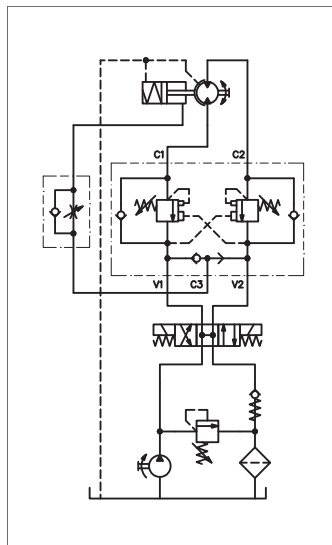

**OPEN LOOP SYSTEM , ONE BRAKE-MOTOR, BI-DIRECTIONAL TURNING AND AUTOMATIC BRAKE OPERATION.**

This configuration is typically that of a slew drive (cranes, excavators, aerial platforms, derricks, etc.). When the pump delivers oil to the motor the consequent generation of pressure will operate the shuttle valve and activate the brake line, thus disengaging the brake itself. When the oil delivery is shut off to stop the machine, a double overcentre valve will slow down the rotating mass to an almost complete stop when the static brake will engage.

**CIRCUITO APERTO, DUE MOTORI FRENO, ROTAZIONE IN ENTRAMBE LE DIREZIONI ED AZIONAMENTO AUTOMATICO DEL FRENO.**

Questo è uno schema abbastanza comune di un impianto di traslazione per macchine mobili (piattaforme aeree, etc.). Il fluido in pressione sblocca il freno e fa partire i due motori; una apposita valvola collega i due motori o in serie o in parallelo in modo da avere più velocità o più coppia. La doppia valvola overcentre rallenta con sicurezza la macchina e la porta fino quasi all'arresto quando i due freni statici entrano in funzione.

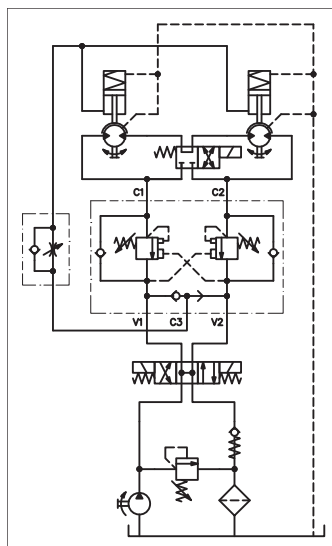

**OPEN LOOP SYSTEM , TWO BRAKEMOTORS, BI-DIRECTIONAL TURNING AND AUTOMATIC BRAKES OPERATION.**

This is a typical layout of the travelling system of a mobile machine (aerial platforms, etc.). Fluid under pressure disengages the brakes and starts the two motors; a commutation device will connect the two motors either in series or parallel mode in order to have either speed or torque as main performance. The double overcentre valve will steadily slow down the machine and bring it to an almost complete stop when the brakes will engage.

**CIRCUITO CHIUSO, UN MOTORE FRENO, ROTAZIONE IN ENTRAMBE LE DIREZIONI, FRENATURA AUTOMATICA, POMPA A PORTATA VARIABILE.**

Questo è un tipico impianto di traslazione per spazzatrici ad una ruota motrice. La pompa impiegata consente di azionare il motore a velocità variabile. Il freno viene bloccato dall'invio di olio dalla valvola commutatrice attraverso l'elettrovalvola che consente anche il deflusso del fluido in pressione dalla camera del freno quando il motore si arresta ed il freno stesso entra in azione.

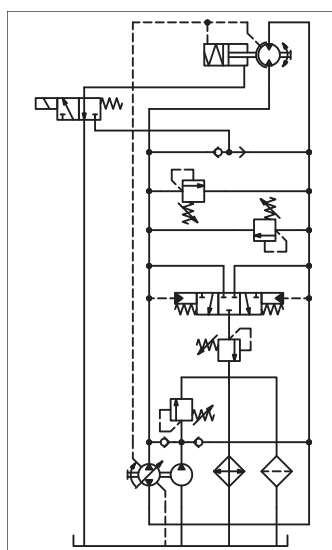

**CLOSED LOOP SYSTEM, ONE BRAKEMOTOR, BI-DIRECTIONAL TURNING, AUTOMATIC BRAKE OPERATION AND VARIABLE PUMP.**

A very typical system for sweepers. The pump delivers a variable flow of oil to the motor hence the machine can travel at variable speed. The brake is disengaged by the deliver of flow from the shuttle valve via the electrovalve (top, right) that will also release the fluid under pressure from inside the brake piston chamber when the motor stops and the brake engages.

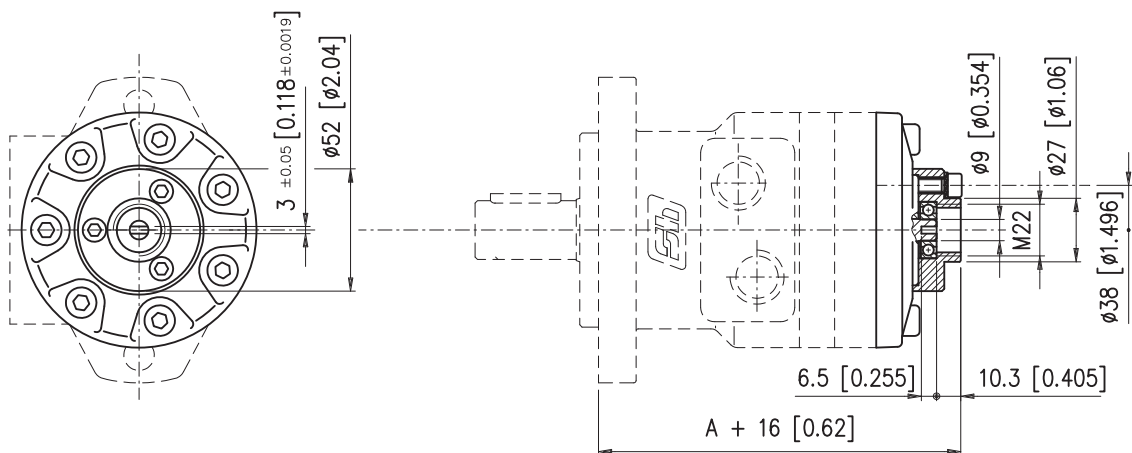

Contagiri disponibile sui motori: **ARS**  
Tacho-meter available on motors: **ARF**

**ATTENZIONE:** L'alberino contagiri ha velocità pari a 6 volte quella dell'albero primario del motore a senso di rotazione opposto.  
**WARNING:** The tacho shaft revolution speed is 6 times more than the motor one and opposite direction of rotation.

**N.B.:** Non sono accettati carichi assiali o radiali sull'albero contagiri. Coppia massima trasmissibile 1 Nm.  
**NOTE:** Axial or radial load on tacho shaft must be avoided. Max torque on tacho shaft 1 Nm [0.73 lbf-ft].

La quota "A" è riferita al dimensionale del motore senza contagiri.  
"A" dimension is related to motor length without tacho.

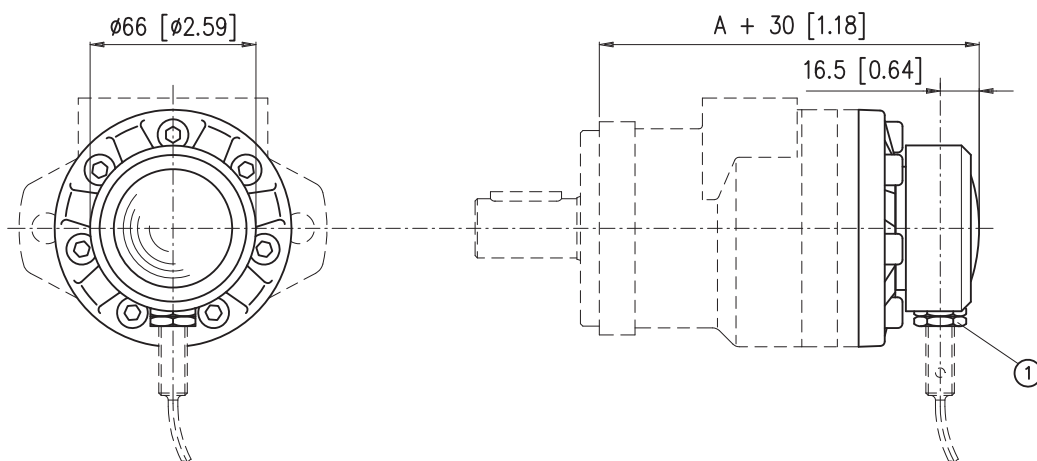

Contagiri elettronico disponibile sui motori: **ARS, ARF**

Numero d'impulsi per giro = 90

La quota "A" è riferita al dimensionale del motore senza contagiri elettronico

1) Attacco sensore M8x1

**ATTENZIONE:**

- Il motore viene fornito senza il sensore elettronico: se necessario, richiederlo in fase di ordinazione.
- Pressione massima ammessa in carcassa: 20 bar.

Electronic tacho-metre available on motors: **ARS, ARF**

Number of pulses per revolution = 90

"A" dimension is related to motor length without electronic tacho

1) Sensor thread M8x1

**WARNING**

- The electronic sensor is not supplied: if required, please state it clearly on order form.
- Max case pressure admissible on the shaft seal with closed drain port: 20 bar [290 psi].

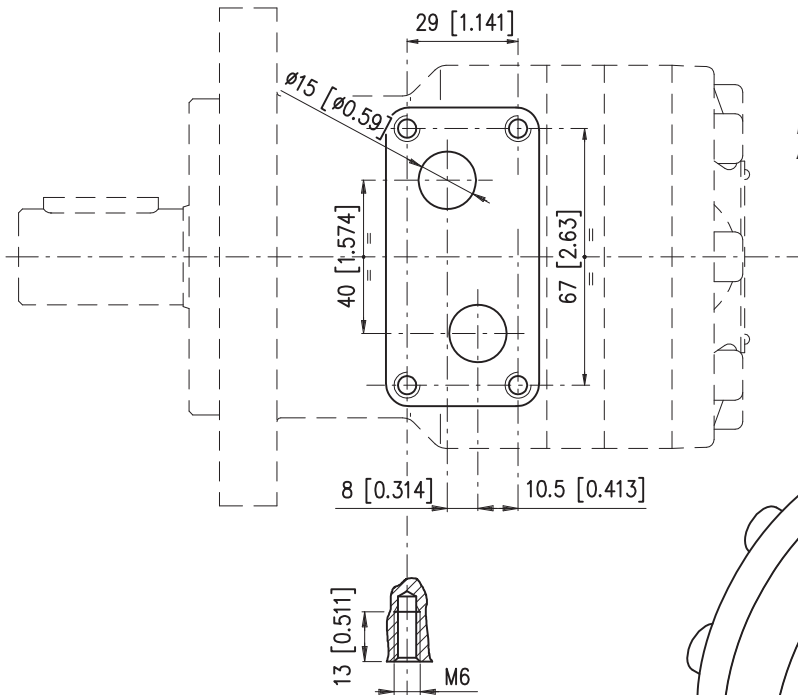

**Predisposizione disponibile per i motori: ARS**  
**Available for the following motors:**

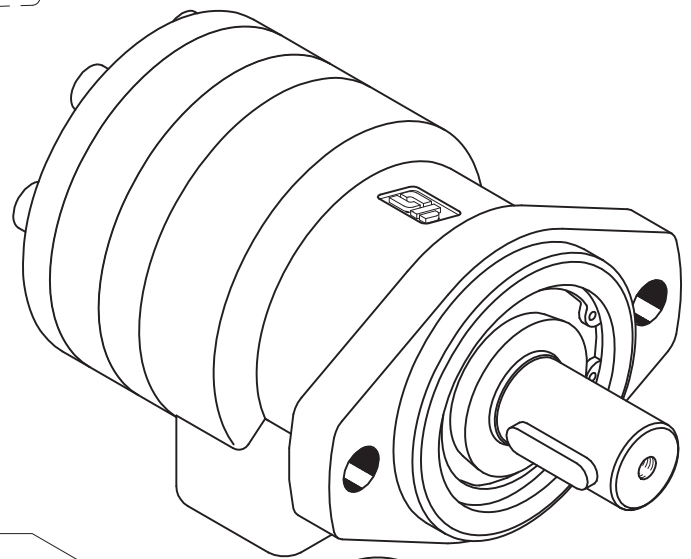

- 2 Guarnizioni O-Ring 2-117 (cod. 410.0160.0000)
- 2 O-Ring gaskets 2-117 (cod. 410.0160.0000)

- 1 Collettore BFL1 (cod. 321.0010.0000)
- 1 BFL1 manifold (cod. 321.0010.0000)

- 4 Viti T.C.E.I. M6x35 (cod. 490.0206.0350)
- 4 T.C.E.I. screws M6x35 (cod. 490.0206.0350)

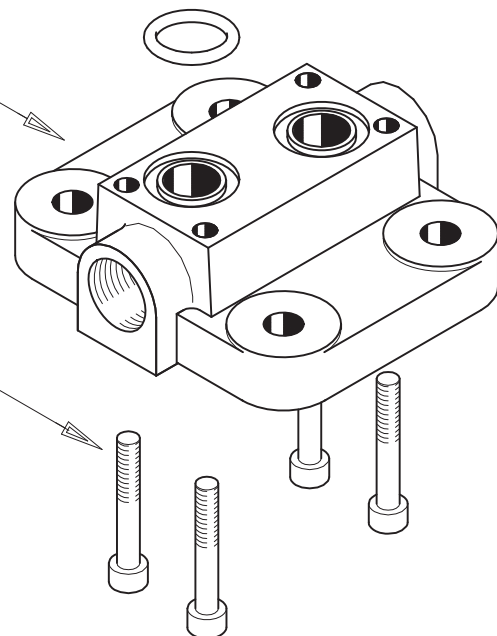

**N.B. L'ordine del "KIT" BFL 1, o dei singoli particolari, deve essere eseguito a parte (cod. Kit 109.0100.9000)**  
**NOTE: The BFL 1 "KIT" or the single components must be ordered separately (Kit Code: 109.0100.9000)**

# AR 50

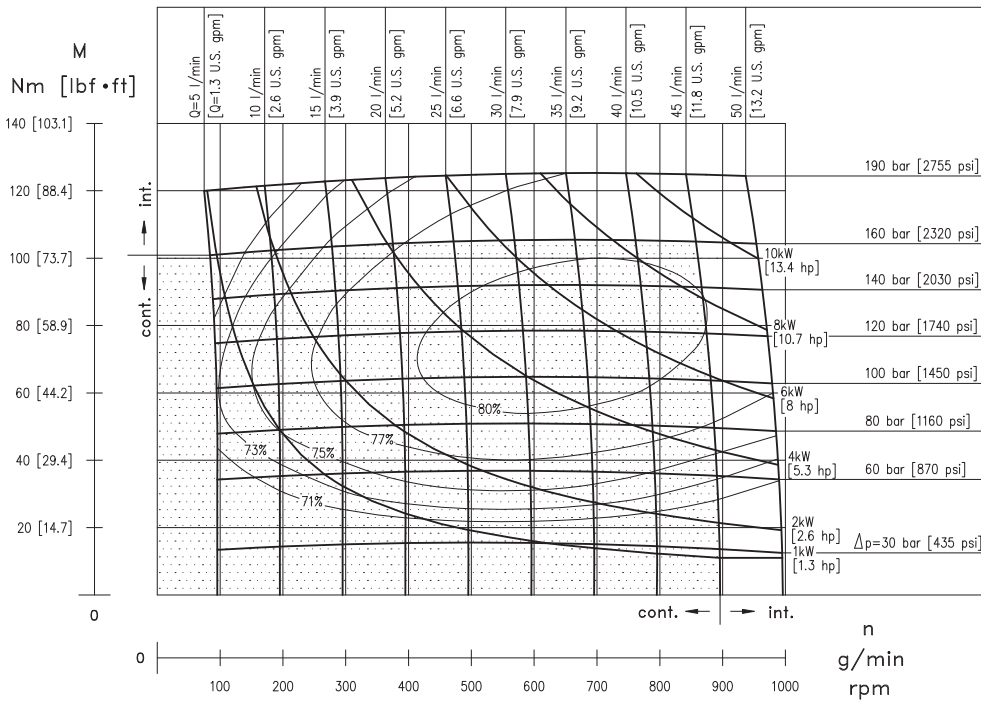

*Pressioni e portate superiori a quelle ammesse in regime continuo non devono essere applicate contemporaneamente.*  
Exceeding continuous pressure values or exceeding flow values indicated, must not occur simultaneously.

# AR 80

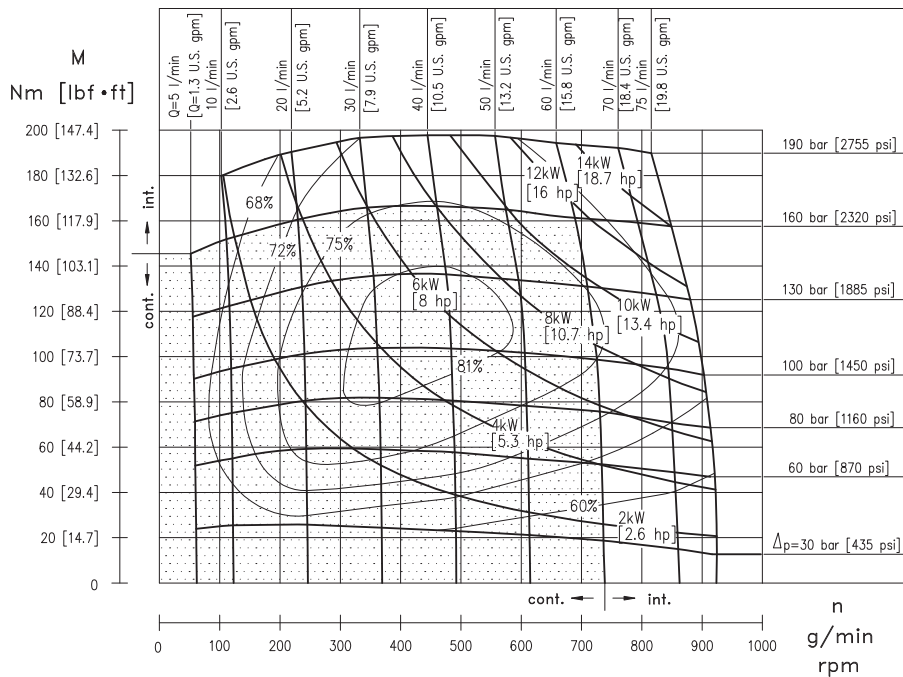

*Pressioni e portate superiori a quelle ammesse in regime continuo non devono essere applicate contemporaneamente.*  
Exceeding continuous pressure values or exceeding flow values indicated, must not occur simultaneously.

# AR 100

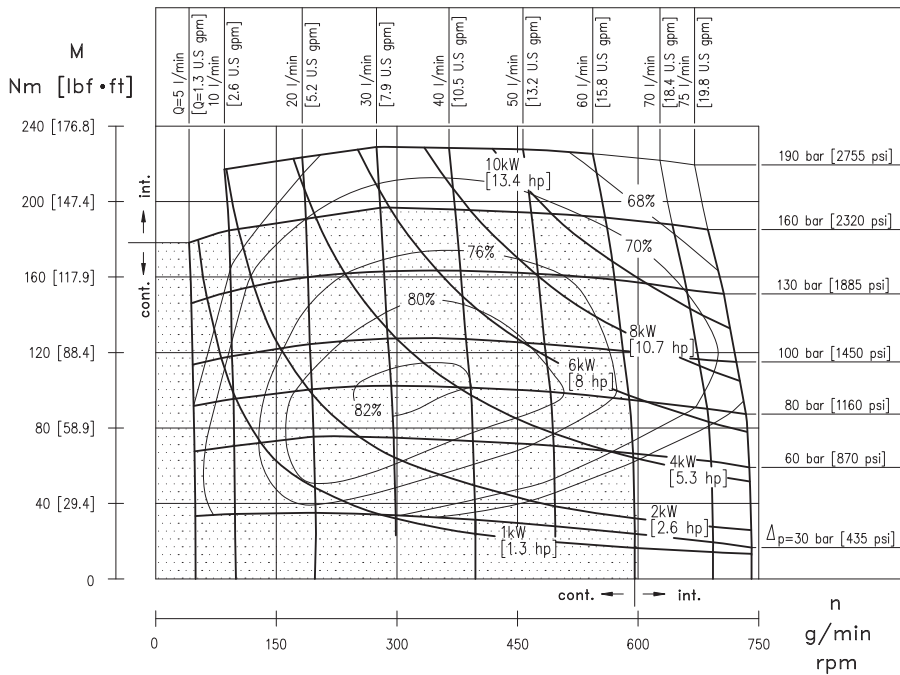

Pressioni e portate superiori a quelle ammesse in regime continuo non devono essere applicate contemporaneamente. Exceeding continuous pressure values or exceeding flow values indicated, must not occur simultaneously.

# AR 130

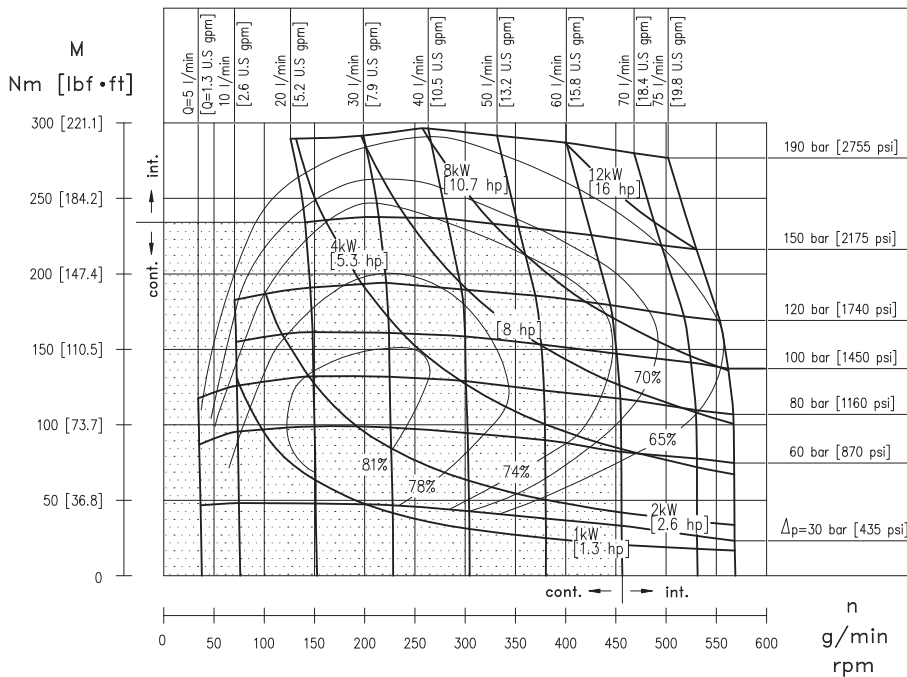

Pressioni e portate superiori a quelle ammesse in regime continuo non devono essere applicate contemporaneamente. Exceeding continuous pressure values or exceeding flow values indicated, must not occur simultaneously.

# AR 160

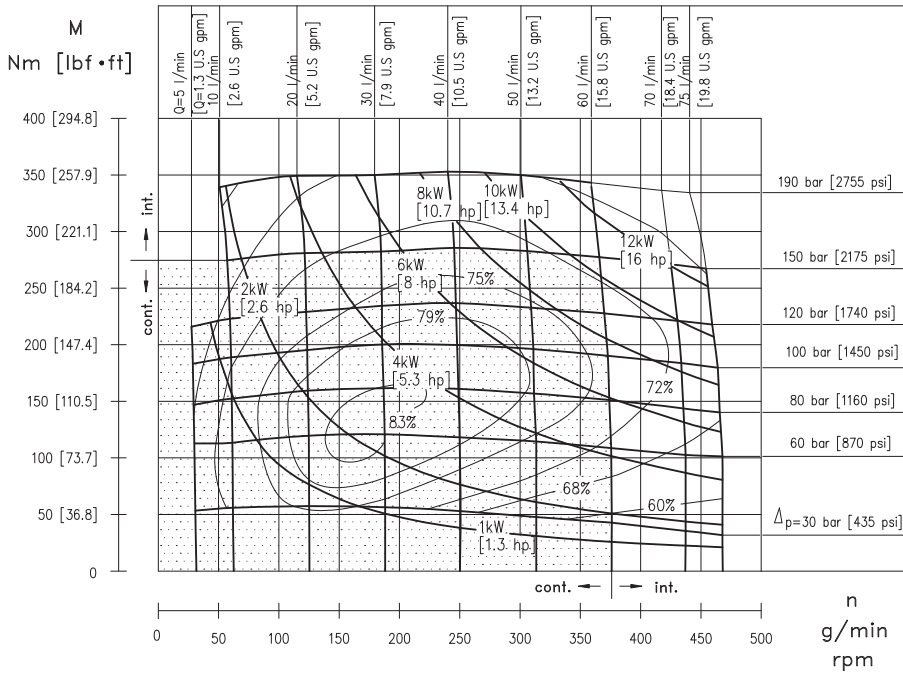

Pressioni e portate superiori a quelle ammesse in regime continuo non devono essere applicate contemporaneamente. Exceeding continuous pressure values or exceeding flow values indicated, must not occur simultaneously.

# AR 200

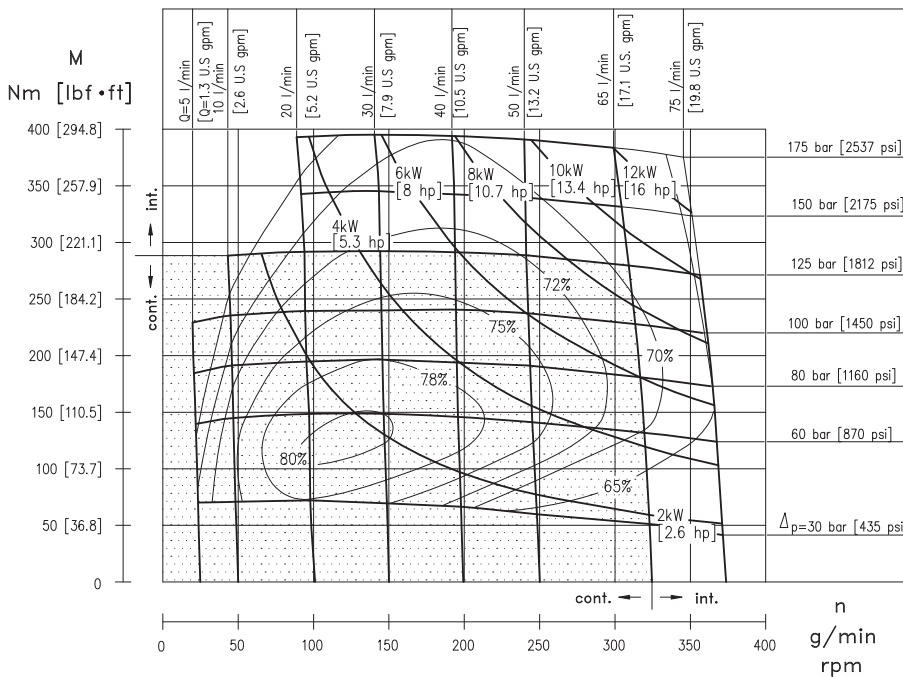

Pressioni e portate superiori a quelle ammesse in regime continuo non devono essere applicate contemporaneamente. Exceeding continuous pressure values or exceeding flow values indicated, must not occur simultaneously.



# AR 250

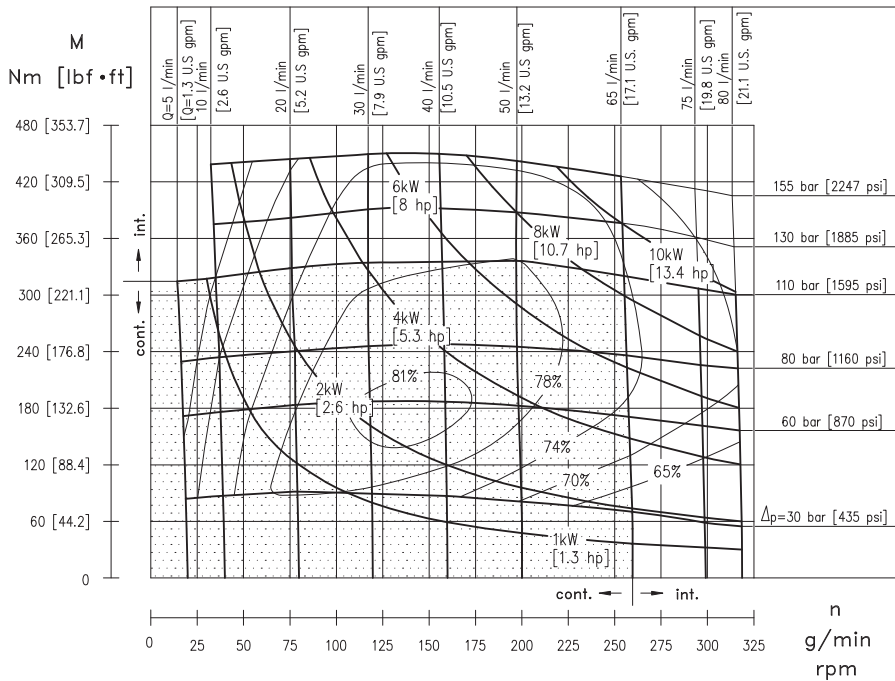

Pressioni e portate superiori a quelle ammesse in regime continuo non devono essere applicate contemporaneamente. Exceeding continuous pressure values or exceeding flow values indicated, must not occur simultaneously.

# AR 315

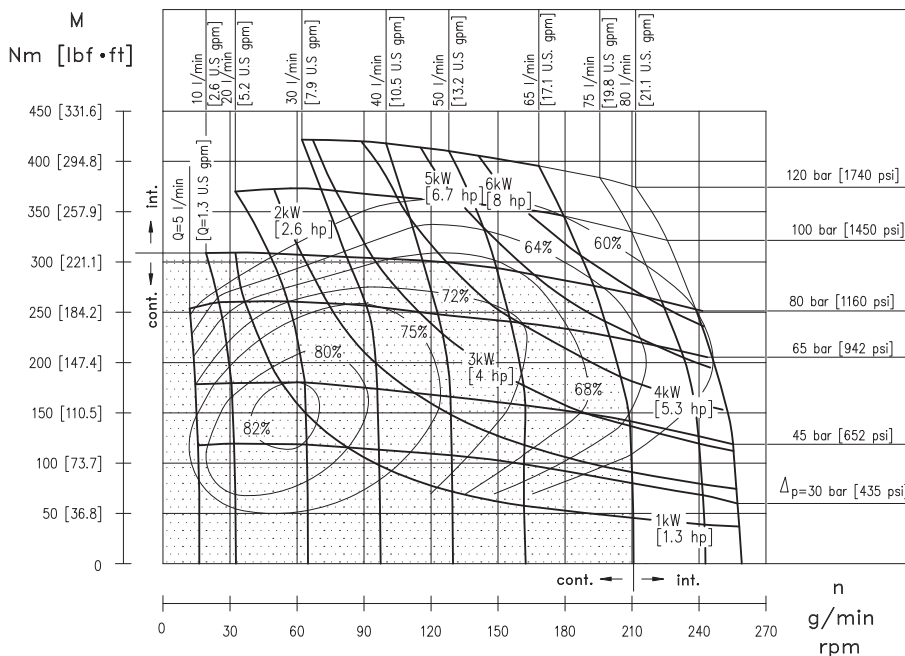

Pressioni e portate superiori a quelle ammesse in regime continuo non devono essere applicate contemporaneamente. Exceeding continuous pressure values or exceeding flow values indicated, must not occur simultaneously.

# AR 400

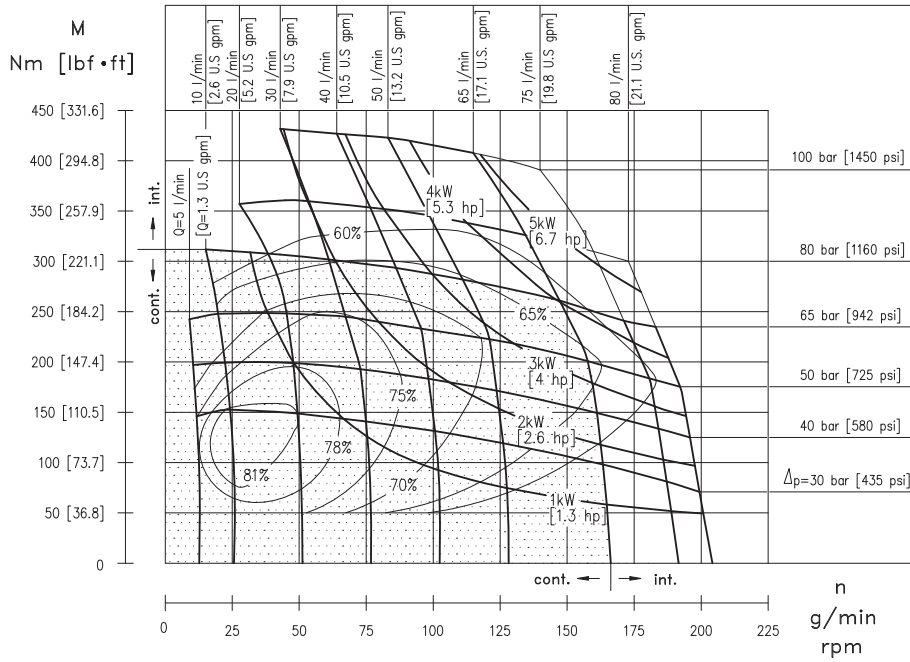

*Pressioni e portate superiori a quelle ammesse in regime continuo non devono essere applicate contemporaneamente.*  
Exceeding continuous pressure values or exceeding flow values indicated, must not occur simultaneously.



# CARICHI AMMESSI SULL'ALBERO SHAFT LOAD CAPACITY

## ARS

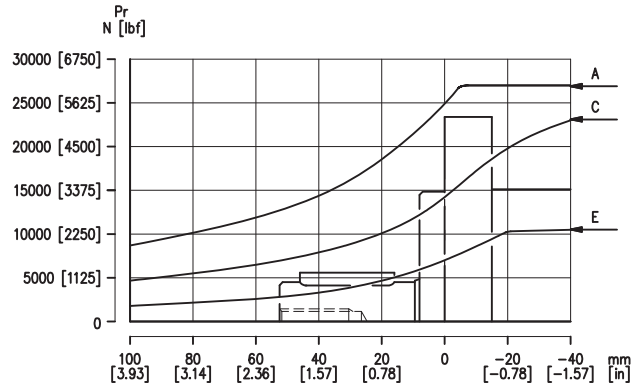
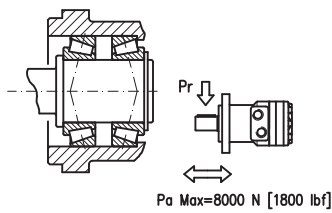

## ARSW

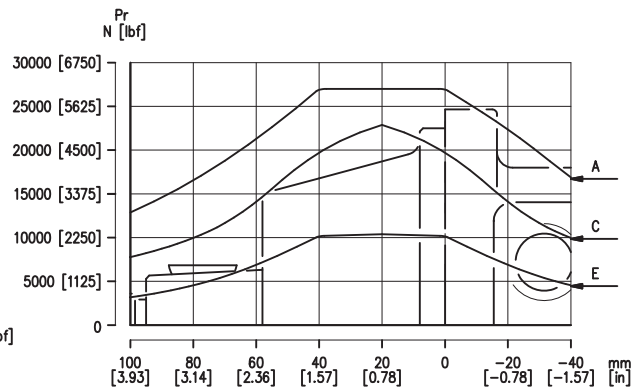
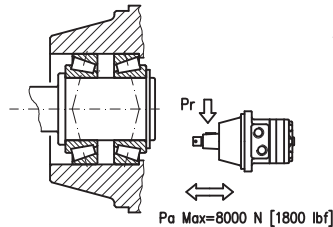

## ARF

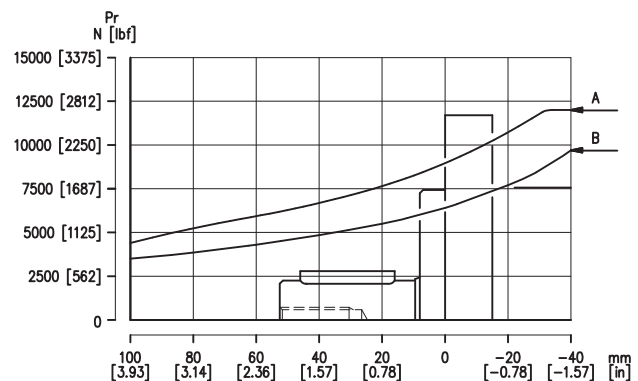
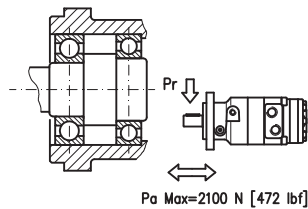

I diagrammi dei carichi sono validi per una vita dei cuscinetti di 1.600 ore a 200 min<sup>-1</sup>, in rif. alla norma ISO 281 (3.3.) lubrificati con olio a base minerale contenente additivi antiusura.

La curva "A" evidenzia il carico statico massimo sopportabile dai cuscinetti.

La curva "B" fornisce il carico radiale limite senza nessuna forza assiale concomitante.

La curva "C" fornisce il carico radiale limite in concomitanza con una forza assiale pari a 2000 N.

La curva "D" fornisce il carico radiale limite in concomitanza con una forza assiale pari a 6000 N.

La curva "E" fornisce il carico radiale limite in concomitanza con una forza assiale pari a 8000 N.

The load diagrams are valid for an average bearings life of 1.600 hrs at 200 r.p.m. with mineral base lubricating oil containing anti-wear additives (ref. ISO 281 (3.3) standard).

The "A" curve gives the maximum static load affordable by the bearings.

The "B" curve gives the radial load top limit without axial loading.

The "C" curve gives the radial load top limit with an axial load of 2000 N [450 lbf].

The "D" curve gives the radial load top limit with an axial load of 6000 N [1350 lbf].

The "E" curve gives the radial load top limit with an axial load of 8000 N [1800 lbf].





**BREVINI<sup>®</sup>**

*Motion Systems*

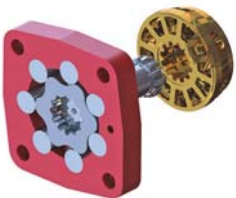
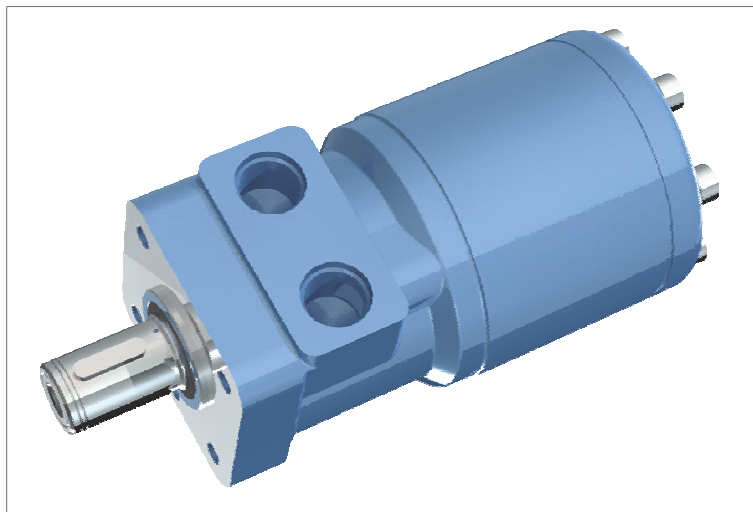

**BR - BS**

***MOTORI ORBITALI***

**ORBITAL MOTORS**

# CARATTERISTICHE DEL MOTORE MOTOR FEATURES

**BR O**

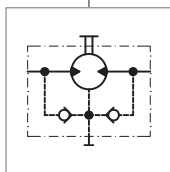

**2A**

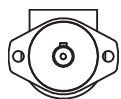

**6A**



**S4**

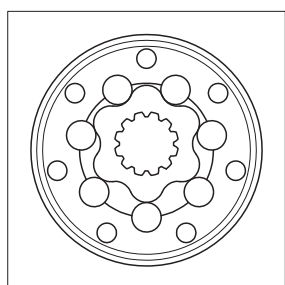

*Roller ad alto rendimento per elevate prestazioni e durata.  
High-performance roller for improved efficiency and life.*

**BR E**

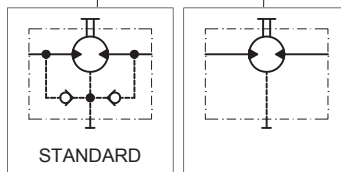

**2A**

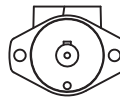

**BS O**

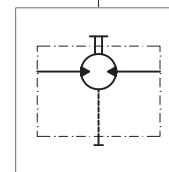

**6A**

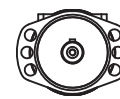

**S4**

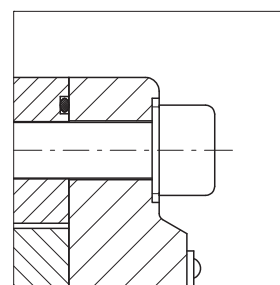

*Viti del coperchio posteriore in acciaio ad alta resistenza per sopportare gli sforzi indotti dall'alta pressione.  
High resistance stainless steel screws capable of withstanding the stress induced by high pressure.*

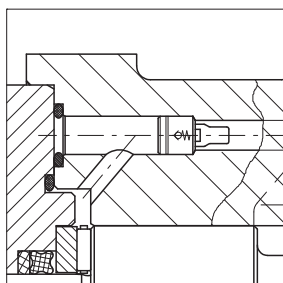

*Valvole di drenaggio incorporate: ricircolano allo scarico il fluido drenato internamente.*

*Built in check valves: to relieve case pressure to the low pressure side of the motor.*

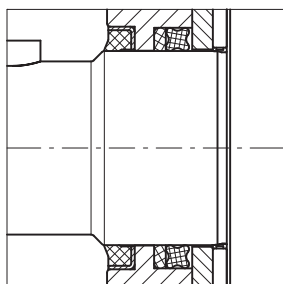

*Parapolvere per proteggere la guarnizione di tenuta dell'albero dalle impurità e guarnizione di tenuta ad alte prestazioni.*

*Dust seal to protect the high pressure shaft seal from dust and debris.*

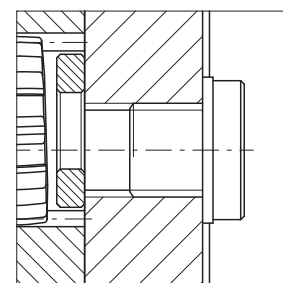
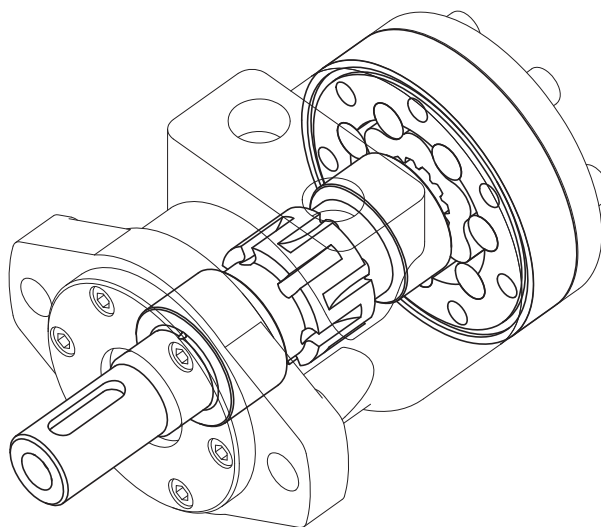

*Foro drenaggio posteriore per un facile collegamento.  
Case drain at rear (shown with plug).*

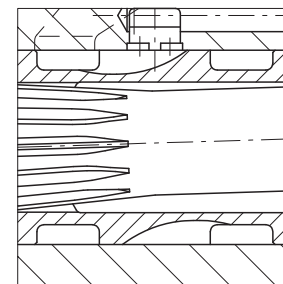

*Valvola distributrice radiale ed albero in un solo pezzo con tolleranze ridotte al minimo per assicurare un drenaggio ridotto.*

*Spool valve integral to the output shaft of new design features optimizing clearance geometry and so minimizing the oil slippage.*

**DATI TECNICI PER MOTORE BR CON ALBERI CILINDRICI CL250 E LC254**  
**BR MOTOR TECHNICAL DATA WITH CL250 AND LC254 PARALLEL KEYS SHAFT**

Motore Motor	Cilindrata Displacement cm <sup>3</sup> /rev [in <sup>3</sup> /rev]	Pressione max ingresso Max. input pressure bar [psi]		Pressione diff. max. Max. differential pressure bar [psi]		Coppia max. Max. torque Nm [lbf-ft]		Portata max. Max. flow l/min [U.S. gpm]		Velocità max. Max. speed giri/min [rpm]		Potenza max. Max. power kW [hp]	
		Cont Int <sup>(1)</sup> Peak <sup>(2)</sup>	175 [2537] 200 [2900] 225 [3262]	Cont Int <sup>(1)</sup> Peak <sup>(2)</sup>	140 [2030] 175 [2540] 225 [3262]	Cont Int <sup>(1)</sup>	103 [75.9] 126 [92.8]	Cont Int <sup>(1)</sup>	40 [10.6] 50 [13.2]	Cont Int <sup>(1)</sup>	775 969	Cont Int <sup>(1)</sup>	6.8 [9.1] 8.4 [11.2]
<b>BR 050</b>	51.6 [3.14]	Cont Int <sup>(1)</sup> Peak <sup>(2)</sup>	175 [2537] 200 [2900] 225 [3262]	Cont Int <sup>(1)</sup> Peak <sup>(2)</sup>	140 [2030] 175 [2540] 225 [3262]	Cont Int <sup>(1)</sup>	103 [75.9] 126 [92.8]	Cont Int <sup>(1)</sup>	40 [10.6] 50 [13.2]	Cont Int <sup>(1)</sup>	775 969	Cont Int <sup>(1)</sup>	6.8 [9.1] 8.4 [11.2]
<b>BR 065</b>	64.9 [3.95]	Cont Int <sup>(1)</sup> Peak <sup>(2)</sup>	175 [2537] 200 [2900] 225 [3262]	Cont Int <sup>(1)</sup> Peak <sup>(2)</sup>	150 [2175] 185 [2682] 225 [3262]	Cont Int <sup>(1)</sup>	140 [103.1] 166 [122.3]	Cont Int <sup>(1)</sup>	50 [13.2] 60 [15.9]	Cont Int <sup>(1)</sup>	770 924	Cont Int <sup>(1)</sup>	9.2 [12.3] 10.6 [14.2]
<b>BR 080</b>	80.4 [4.9]	Cont Int <sup>(1)</sup> Peak <sup>(2)</sup>	175 [2537] 200 [2900] 225 [3262]	Cont Int* Peak <sup>(2)</sup>	175 [2537] 200 [2900] 225 [3262]	Cont Int*	197 [145.1] 218 [160.6]	Cont Int <sup>(1)</sup>	60 [15.9] 75 [19.8]	Cont Int <sup>(1)</sup>	746 933	Cont Int <sup>(1)</sup>	13 [17.4] 15 [20.1]
<b>BR 100</b>	100 [6.1]	Cont Int <sup>(1)</sup> Peak <sup>(2)</sup>	175 [2537] 200 [2900] 225 [3262]	Cont Int <sup>(1)</sup> Peak <sup>(2)</sup>	175 [2537] 200 [2900] 225 [3262]	Cont Int <sup>(1)</sup>	237 [174.6] 277 [204.1]	Cont Int <sup>(1)</sup>	60 [15.9] 75 [19.8]	Cont Int <sup>(1)</sup>	600 750	Cont Int <sup>(1)</sup>	13 [17.4] 15 [20.1]
<b>BR 130</b>	125.7 [7.66]	Cont Int <sup>(1)</sup> Peak <sup>(2)</sup>	175 [2537] 200 [2900] 225 [3262]	Cont Int <sup>(1)</sup> Peak <sup>(2)</sup>	175 [2537] 200 [2900] 225 [3262]	Cont Int <sup>(1)</sup>	300 [221.1] 340 [250.5]	Cont Int <sup>(1)</sup>	60 [15.9] 75 [19.8]	Cont Int <sup>(1)</sup>	477 597	Cont Int <sup>(1)</sup>	12.5 [16.8] 14.5 [19.4]
<b>BR 160</b>	160 [9.76]	Cont Int <sup>(1)</sup> Peak <sup>(2)</sup>	175 [2537] 200 [2900] 225 [3262]	Cont Int <sup>(1)</sup> Peak <sup>(2)</sup>	140 [2030] 175 [2540] 225 [3262]	Cont Int <sup>(1)</sup>	296 [218.1] 375 [276.3]	Cont Int <sup>(1)</sup>	60 [15.9] 75 [19.8]	Cont Int <sup>(1)</sup>	375 469	Cont Int <sup>(1)</sup>	10 [13.4] 12.5 [16.8]
<b>BR 200</b>	200 [12.2]	Cont Int <sup>(1)</sup> Peak <sup>(2)</sup>	175 [2537] 200 [2900] 225 [3262]	Cont Int <sup>(1)</sup> Peak <sup>(2)</sup>	115 [1667] 140 [2030] 225 [3262]	Cont Int <sup>(1)</sup>	297 [218.8] 380 [280]	Cont Int <sup>(1)</sup>	60 [15.9] 75 [19.8]	Cont Int <sup>(1)</sup>	300 375	Cont Int <sup>(1)</sup>	8.5 [11] 10 [13.4]
<b>BR 250</b>	250 [15.2]	Cont Int <sup>(1)</sup> Peak <sup>(2)</sup>	175 [2537] 200 [2900] 225 [3262]	Cont Int <sup>(1)</sup> Peak <sup>(2)</sup>	90 [1305] 120 [1740] 225 [3262]	Cont Int <sup>(1)</sup>	297 [218.8] 377 [277.8]	Cont Int <sup>(1)</sup>	60 [15.9] 75 [19.8]	Cont Int <sup>(1)</sup>	240 300	Cont Int <sup>(1)</sup>	7.1 [9.5] 8.5 [11.1]
<b>BR 315</b>	314.5 [19.1]	Cont Int <sup>(1)</sup> Peak <sup>(2)</sup>	175 [2537] 200 [2900] 225 [3262]	Cont Int <sup>(1)</sup> Peak <sup>(2)</sup>	70 [1020] 100 [1450] 210 [3045]	Cont Int <sup>(1)</sup>	300 [221.1] 420 [309.5]	Cont Int <sup>(1)</sup>	60 [15.9] 75 [19.8]	Cont Int <sup>(1)</sup>	191 238	Cont Int <sup>(1)</sup>	5 [6.7] 6.6 [8.8]
<b>BR 400</b>	393 [23.9]	Cont Int <sup>(1)</sup> Peak <sup>(2)</sup>	175 [2537] 200 [2900] 225 [3262]	Cont Int <sup>(1)</sup> Peak <sup>(2)</sup>	55 [800] 85 [1230] 175 [2537]	Cont Int <sup>(1)</sup>	292 [215.2] 425 [313.2]	Cont Int <sup>(1)</sup>	60 [15.9] 75 [19.8]	Cont Int <sup>(1)</sup>	153 191	Cont Int <sup>(1)</sup>	4.1 [5.4] 6.1 [8.1]

**DATI TECNICI PER MOTORE BR CON ALBERO SCANALATO SD250**  
**BR MOTOR TECHNICAL DATA WITH SD250 SPLINED SHAFT**

Motore Motor	Cilindrata Displacement cm <sup>3</sup> /rev [in <sup>3</sup> /rev]	Pressione max ingresso Max. input pressure bar [psi]		Pressione diff. max. Max. differential pressure bar [psi]		Coppia max. Max. torque Nm [lbf-ft]		Portata max. Max. flow l/min [U.S. gpm]		Velocità max. Max. speed giri/min [rpm]		Potenza max. Max. power kW [hp]	
		Cont Int <sup>(1)</sup> Peak <sup>(2)</sup>	175 [2537] 200 [2900] 225 [3262]	Cont Int <sup>(1)</sup> Peak <sup>(2)</sup>	140 [2030] 175 [2540] 225 [3262]	Cont Int <sup>(1)</sup>	103 [75.9] 126 [92.8]	Cont Int <sup>(1)</sup>	40 [10.6] 50 [13.2]	Cont Int <sup>(1)</sup>	775 969	Cont Int <sup>(1)</sup>	6.8 [9.1] 8.4 [11.2]
<b>BR 050</b>	51.6 [3.14]	Cont Int <sup>(1)</sup> Peak <sup>(2)</sup>	175 [2537] 200 [2900] 225 [3262]	Cont Int <sup>(1)</sup> Peak <sup>(2)</sup>	140 [2030] 175 [2540] 225 [3262]	Cont Int <sup>(1)</sup>	103 [75.9] 126 [92.8]	Cont Int <sup>(1)</sup>	40 [10.6] 50 [13.2]	Cont Int <sup>(1)</sup>	775 969	Cont Int <sup>(1)</sup>	6.8 [9.1] 8.4 [11.2]
<b>BR 065</b>	64.9 [3.95]	Cont Int <sup>(1)</sup> Peak <sup>(2)</sup>	175 [2537] 200 [2900] 225 [3262]	Cont Int <sup>(1)</sup> Peak <sup>(2)</sup>	150 [2175] 185 [2682] 225 [3262]	Cont Int <sup>(1)</sup>	140 [103.1] 166 [122.3]	Cont Int <sup>(1)</sup>	50 [13.2] 60 [15.9]	Cont Int <sup>(1)</sup>	770 924	Cont Int <sup>(1)</sup>	9.2 [12.3] 10.6 [14.2]
<b>BR 080</b>	80.4 [4.9]	Cont Int <sup>(1)</sup> Peak <sup>(2)</sup>	175 [2537] 200 [2900] 225 [3262]	Cont Int* Peak <sup>(2)</sup>	175 [2537] 200 [2900] 225 [3262]	Cont Int*	197 [145.1] 218 [160.6]	Cont Int <sup>(1)</sup>	60 [15.9] 75 [19.8]	Cont Int <sup>(1)</sup>	746 933	Cont Int <sup>(1)</sup>	13 [17.4] 15 [20.1]
<b>BR 100</b>	100 [6.1]	Cont Int <sup>(1)</sup> Peak <sup>(2)</sup>	175 [2537] 200 [2900] 225 [3262]	Cont Int <sup>(1)</sup> Peak <sup>(2)</sup>	175 [2537] 200 [2900] 225 [3262]	Cont Int <sup>(1)</sup>	237 [174.6] 277 [204.1]	Cont Int <sup>(1)</sup>	60 [15.9] 75 [19.8]	Cont Int <sup>(1)</sup>	600 750	Cont Int <sup>(1)</sup>	13 [17.4] 15 [20.1]
<b>BR 130</b>	125.7 [7.66]	Cont Int <sup>(1)</sup> Peak <sup>(2)</sup>	175 [2537] 200 [2900] 225 [3262]	Cont Int <sup>(1)</sup> Peak <sup>(2)</sup>	175 [2537] 200 [2900] 225 [3262]	Cont Int <sup>(1)</sup>	300 [221.1] 340 [250.5]	Cont Int <sup>(1)</sup>	60 [15.9] 75 [19.8]	Cont Int <sup>(1)</sup>	477 597	Cont Int <sup>(1)</sup>	12.5 [16.8] 14.5 [19.4]
<b>BR 160</b>	160 [9.76]	Cont Int <sup>(1)</sup> Peak <sup>(2)</sup>	175 [2537] 200 [2900] 225 [3262]	Cont Int <sup>(1)</sup> Peak <sup>(2)</sup>	165 [2390] 200 [2900] 225 [3262]	Cont Int <sup>(1)</sup>	350 [257.9] 428 [315.4]	Cont Int <sup>(1)</sup>	60 [15.9] 75 [19.8]	Cont Int <sup>(1)</sup>	375 469	Cont Int <sup>(1)</sup>	11.8 [15.8] 14.3 [19.1]
<b>BR 200</b>	200 [12.2]	Cont Int <sup>(1)</sup> Peak <sup>(2)</sup>	175 [2537] 200 [2900] 225 [3262]	Cont Int <sup>(1)</sup> Peak <sup>(2)</sup>	130 [1890] 165 [2390] 225 [3262]	Cont Int <sup>(1)</sup>	335 [246.8] 446 [328.7]	Cont Int <sup>(1)</sup>	60 [15.9] 75 [19.8]	Cont Int <sup>(1)</sup>	300 375	Cont Int <sup>(1)</sup>	9.7 [12.9] 12 [16]
<b>BR 250</b>	250 [15.2]	Cont Int <sup>(1)</sup> Peak <sup>(2)</sup>	175 [2537] 200 [2900] 225 [3262]	Cont Int <sup>(1)</sup> Peak <sup>(2)</sup>	105 [1522] 135 [1957] 225 [3262]	Cont Int <sup>(1)</sup>	347 [255.7] 424 [312.4]	Cont Int <sup>(1)</sup>	60 [15.9] 75 [19.8]	Cont Int <sup>(1)</sup>	240 300	Cont Int <sup>(1)</sup>	8.3 [11.1] 9.6 [12.8]
<b>BR 315</b>	314.5 [19.1]	Cont Int <sup>(1)</sup> Peak <sup>(2)</sup>	175 [2537] 200 [2900] 225 [3262]	Cont Int <sup>(1)</sup> Peak <sup>(2)</sup>	85 [1232] 115 [1670] 210 [3045]	Cont Int <sup>(1)</sup>	362 [266.7] 484 [356.7]	Cont Int <sup>(1)</sup>	60 [15.9] 75 [19.8]	Cont Int <sup>(1)</sup>	191 238	Cont Int <sup>(1)</sup>	6 [8] 7.6 [10.1]
<b>BR 400</b>	393 [23.9]	Cont Int <sup>(1)</sup> Peak <sup>(2)</sup>	175 [2537] 200 [2900] 225 [3262]	Cont Int <sup>(1)</sup> Peak <sup>(2)</sup>	65 [942] 90 [1310] 175 [2537]	Cont Int <sup>(1)</sup>	345 [254.2] 450 [331.6]	Cont Int <sup>(1)</sup>	60 [15.9] 75 [19.8]	Cont Int <sup>(1)</sup>	153 191	Cont Int <sup>(1)</sup>	4.9 [6.5] 6.5 [8.7]

**DATI TECNICI PER MOTORE BR CON ALBERI CILINDRICI CL320, C3175 E CONICO CN320**  
**BR MOTOR TECHNICAL DATA WITH CL320, C3175 PARALLEL KEYED SHAFT AND CN320 TAPERED SHAFT**

Motore Motor	Cilindrata Displacement cm <sup>3</sup> /rev [in <sup>3</sup> /rev]	Pressione max ingresso Max. input pressure bar [psi]		Pressione diff. max. Max. differential pressure bar [psi]		Coppia max. Max. torque Nm [lbf-ft]		Portata max. Max. flow l/min [U.S. gpm]		Velocità max. Max. speed giri/min [rpm]		Potenza max. Max. power kW [hp]	
		Cont Int <sup>1)</sup> Peak <sup>2)</sup>	175 [2537] 200 [2900] 225 [3262]	Cont Int <sup>1)</sup> Peak <sup>2)</sup>	140 [2030] 175 [2540] 225 [3262]	Cont Int <sup>1)</sup>	103 [75.9] 126 [92.8]	Cont Int <sup>1)</sup>	40 [10.6] 50 [13.2]	Cont Int <sup>1)</sup>	775 969	Cont Int <sup>1)</sup>	6.8 [9.1] 8.4 [11.2]
BR 050	51.6 [3.14]	Cont Int <sup>1)</sup> Peak <sup>2)</sup>	175 [2537] 200 [2900] 225 [3262]	Cont Int <sup>1)</sup> Peak <sup>2)</sup>	140 [2030] 175 [2540] 225 [3262]	Cont Int <sup>1)</sup>	103 [75.9] 126 [92.8]	Cont Int <sup>1)</sup>	40 [10.6] 50 [13.2]	Cont Int <sup>1)</sup>	775 969	Cont Int <sup>1)</sup>	6.8 [9.1] 8.4 [11.2]
BR 065	64.9 [3.95]	Cont Int <sup>1)</sup> Peak <sup>2)</sup>	175 [2537] 200 [2900] 225 [3262]	Cont Int <sup>1)</sup> Peak <sup>2)</sup>	150 [2175] 185 [2682] 225 [3262]	Cont Int <sup>1)</sup>	140 [103.1] 166 [122.3]	Cont Int <sup>1)</sup>	50 [13.2] 60 [15.9]	Cont Int <sup>1)</sup>	770 924	Cont Int <sup>1)</sup>	9.2 [12.3] 10.6 [14.2]
BR 080	80.4 [4.9]	Cont Int <sup>1)</sup> Peak <sup>2)</sup>	175 [2537] 200 [2900] 225 [3262]	Cont Int* Peak <sup>2)</sup>	175 [2537] 200 [2900] 225 [3262]	Cont Int*	197 [145.1] 218 [160.6]	Cont Int <sup>1)</sup>	60 [15.9] 75 [19.8]	Cont Int <sup>1)</sup>	746 933	Cont Int <sup>1)</sup>	13 [17.4] 15 [20.1]
BR 100	100 [6.1]	Cont Int <sup>1)</sup> Peak <sup>2)</sup>	175 [2537] 200 [2900] 225 [3262]	Cont Int <sup>1)</sup> Peak <sup>2)</sup>	175 [2537] 200 [2900] 225 [3262]	Cont Int <sup>1)</sup>	237 [174.6] 277 [204.1]	Cont Int <sup>1)</sup>	60 [15.9] 75 [19.8]	Cont Int <sup>1)</sup>	600 750	Cont Int <sup>1)</sup>	13 [17.4] 15 [20.1]
BR 130	125.7 [7.66]	Cont Int <sup>1)</sup> Peak <sup>2)</sup>	175 [2537] 200 [2900] 225 [3262]	Cont Int <sup>1)</sup> Peak <sup>2)</sup>	175 [2537] 200 [2900] 225 [3262]	Cont Int <sup>1)</sup>	300 [221.1] 340 [250.5]	Cont Int <sup>1)</sup>	60 [15.9] 75 [19.8]	Cont Int <sup>1)</sup>	477 597	Cont Int <sup>1)</sup>	12.5 [16.8] 14.5 [19.4]
BR 160	160 [9.76]	Cont Int <sup>1)</sup> Peak <sup>2)</sup>	175 [2537] 200 [2900] 225 [3262]	Cont Int <sup>1)</sup> Peak <sup>2)</sup>	175 [2537] 200 [2900] 225 [3262]	Cont Int <sup>1)</sup>	370 [272.6] 428 [315.4]	Cont Int <sup>1)</sup>	60 [15.9] 75 [19.8]	Cont Int <sup>1)</sup>	375 469	Cont Int <sup>1)</sup>	12.5 [16.8] 14.3 [19.1]
BR 200	200 [12.2]	Cont Int <sup>1)</sup> Peak <sup>2)</sup>	175 [2537] 200 [2900] 225 [3262]	Cont Int <sup>1)</sup> Peak <sup>2)</sup>	175 [2537] 200 [2900] 225 [3262]	Cont Int <sup>1)</sup>	450 [331.6] 540 [397.9]	Cont Int <sup>1)</sup>	60 [15.9] 75 [19.8]	Cont Int <sup>1)</sup>	300 375	Cont Int <sup>1)</sup>	13.4 [17.9] 14.4 [19.2]
BR 250	250 [15.2]	Cont Int <sup>1)</sup> Peak <sup>2)</sup>	175 [2537] 200 [2900] 225 [3262]	Cont Int <sup>1)</sup> Peak <sup>2)</sup>	175 [2537] 200 [2900] 225 [3262]	Cont Int <sup>1)</sup>	578 [425.9] 630 [464.3]	Cont Int <sup>1)</sup>	60 [15.9] 75 [19.8]	Cont Int <sup>1)</sup>	240 300	Cont Int <sup>1)</sup>	13.8 [18.4] 14.2 [19]
BR 315	314.5 [19.1]	Cont Int <sup>1)</sup> Peak <sup>2)</sup>	175 [2537] 200 [2900] 225 [3262]	Cont Int <sup>1)</sup> Peak <sup>2)</sup>	135 [1960] 175 [2537] 210 [3045]	Cont Int <sup>1)</sup>	575 [423.7] 736 [542.4]	Cont Int <sup>1)</sup>	60 [15.9] 75 [19.8]	Cont Int <sup>1)</sup>	191 238	Cont Int <sup>1)</sup>	9.6 [12.8] 11.5 [15.4]
BR 400	393 [23.9]	Cont Int <sup>1)</sup> Peak <sup>2)</sup>	175 [2537] 200 [2900] 225 [3262]	Cont Int <sup>1)</sup> Peak <sup>2)</sup>	115 [1670] 150 [2180] 175 [2537]	Cont Int <sup>1)</sup>	612 [451] 750 [552.7]	Cont Int <sup>1)</sup>	60 [15.9] 75 [19.8]	Cont Int <sup>1)</sup>	153 191	Cont Int <sup>1)</sup>	8.6 [11.5] 10.8 [14.4]

Motore Motor	Max press. di scarico con drenaggio aperto Max back pressure with drain line bar[psi]		Pressione max avviamento a vuoto Max starting pressure in unloaded conditions bar[psi]		Coppia min di spunto Min starting torque Nm[lbf-ft]		Portata di drenaggio <sup>4)</sup> Oil flow in the drain line <sup>4)</sup> l/min [U.S. gpm]		Velocità minima <sup>5)</sup> Min speed <sup>5)</sup> rpm	
	Cont Int <sup>1)</sup> Peak <sup>2)</sup>	175 [2538] 200 [2900] 225 [3263]	10 [145]	at Δp max at Δp max	Cont Int*	75[55.3] 95[70.0]	at Δp=100bar[1450psi] at Δp=140bar[2030psi]	0.7[0.2] 1.6[0.4]	10	
BR 050	Cont Int <sup>1)</sup> Peak <sup>2)</sup>	175 [2538] 200 [2900] 225 [3263]	10 [145]	at Δp max at Δp max	Cont Int*	75[55.3] 95[70.0]	at Δp=100bar[1450psi] at Δp=140bar[2030psi]	0.7[0.2] 1.6[0.4]	10	
BR 065	Cont Int <sup>1)</sup> Peak <sup>2)</sup>	175 [2538] 200 [2900] 225 [3263]	10 [145]	at Δp max at Δp max	Cont Int*	120[88.4] 140[103.1]	at Δp=100bar[1450psi] at Δp=140bar[2030psi]	0.7[0.2] 1.6[0.4]	10	
BR 080	Cont Int <sup>1)</sup> Peak <sup>2)</sup>	175 [2538] 200 [2900] 225 [3263]	10 [145]	at Δp max at Δp max	Cont Int*	160[118] 180[133]	at Δp=100bar[1450psi] at Δp=140bar[2030psi]	0.7[0.2] 1.6[0.4]	10	
BR 100	Cont Int <sup>1)</sup> Peak <sup>2)</sup>	175 [2538] 200 [2900] 225 [3263]	10 [145]	at Δp max at Δp max	Cont Int*	200[147] 225[166]	at Δp=100bar[1450psi] at Δp=140bar[2030psi]	0.7[0.2] 1.6[0.4]	10	
BR 130	Cont Int <sup>1)</sup> Peak <sup>2)</sup>	175 [2538] 200 [2900] 225 [3263]	9 [131]	at Δp max at Δp max	Cont Int*	255[188] 290[214]	at Δp=100bar[1450psi] at Δp=140bar[2030psi]	0.7[0.2] 1.6[0.4]	10	
BR 160	Cont Int <sup>1)</sup> Peak <sup>2)</sup>	175 [2538] 200 [2900] 225 [3263]	7 [102]	at Δp max at Δp max	Cont Int*	310(250)[228(184)] <sup>3)</sup> 360(300)[265(221)] <sup>3)</sup>	at Δp=100bar[1450psi] at Δp=140bar[2030psi]	0.7[0.2] 1.6[0.4]	10	
BR 200	Cont Int <sup>1)</sup> Peak <sup>2)</sup>	175 [2538] 200 [2900] 225 [3263]	5 [72.5]	at Δp max at Δp max	Cont Int*	390(250)[287(184)] <sup>3)</sup> 450(320)[332(236)] <sup>3)</sup>	at Δp=100bar[1450psi] at Δp=140bar[2030psi]	1.5[0.4] 3.0[0.8]	10	
BR 250	Cont Int <sup>1)</sup> Peak <sup>2)</sup>	175 [2538] 200 [2900] 225 [3263]	5 [72.5]	at Δp max at Δp max	Cont Int*	490(250)[361(184)] <sup>3)</sup> 560(310)[413(228)] <sup>3)</sup>	at Δp=100bar[1450psi] at Δp=140bar[2030psi]	1.5[0.4] 3.0[0.8]	10	
BR 315	Cont Int <sup>1)</sup> Peak <sup>2)</sup>	175 [2538] 200 [2900] 225 [3263]	5 [72.5]	at Δp max at Δp max	Cont Int*	470(250)[346(184)] <sup>3)</sup> 610(300)[450(221)] <sup>3)</sup>	at Δp=100bar[1450psi] at Δp=140bar[2030psi]	1.5[0.4] 3.0[0.8]	10	
BR 400	Cont Int <sup>1)</sup> Peak <sup>2)</sup>	175 [2538] 200 [2900] 225 [3263]	5 [72.5]	at Δp max at Δp max	Cont Int*	510(250)[376(184)] <sup>3)</sup> 670(320)[494(236)] <sup>3)</sup>	at Δp=100bar[1450psi] at Δp=140bar[2030psi]	1.5[0.4] 3.0[0.8]	10	

1) Le condizioni intermittenti non devono durare più del 10% ogni minuto. - Intermittent duty must not exceed 10% each minute. 2) Le condizioni di picco non devono durare più del 1% di ogni minuto. - Peak duty must not exceed 1% each minute. 3) I valori tra parentesi si riferiscono alla versione con albero CL250/LC254/SD250. - The values in brackets are referred to CL250/LC254/SD250 shaft. 4) Viscosità dell'olio 37 cSt. - Oil Viscosity 37 cSt. 5) Per impieghi a velocità inferiori o con carichi radiali consultare la Brevini Fluid Power for applications at lower rpm or at high radial loads pls. consult Brevini Fluid Power.

# MASSIMA PRESSIONE AMMESSA SULLA GUARNIZIONE ALBERO MAX PERMISSIBLE SHAFT SEAL PRESSURE

Pressione massima di scarico senza drenaggio o massima pressione nella linea di drenaggio. I motori sono forniti nella versione con guarnizioni standard (diagramma Standard) o nella versione con guarnizioni ad alta pressione (diagramma HPS). Per condizioni di pressione e velocità non contemplate dal presente grafico si consiglia di contattare la Brevini Fluid Power.

N.B.: Sulle versioni con Tachimetro o Freno non è possibile installare guarnizioni HPS.

Max. return pressure without drain line or max. pressure in the drain line. Motor are supplied in standard seal version (Standard chart) or in HPS seal version (HPS chart). For pressure and speeds not showed in the curve below, please contact Brevini Fluid Power.

N.B.: Tachometer or Brake versions is not available with HPS seals.

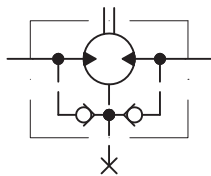
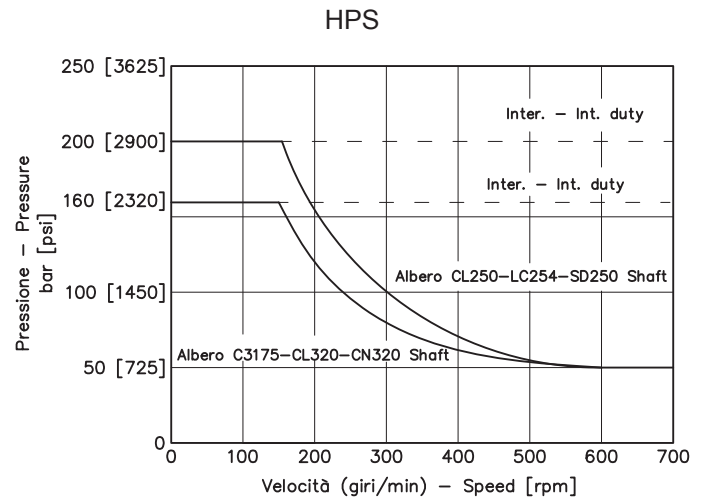
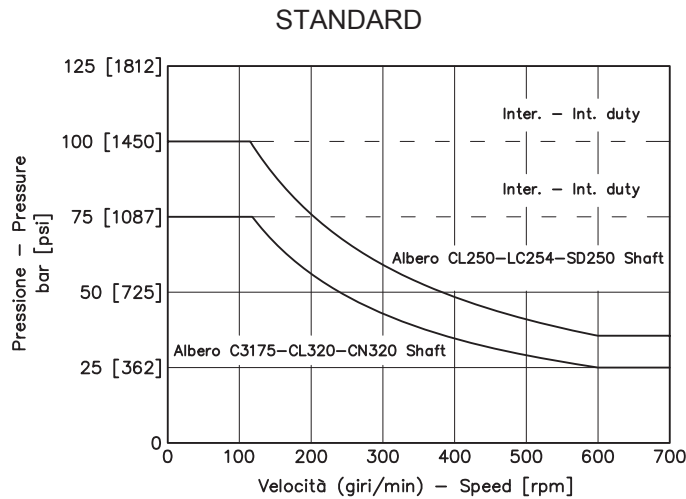

# PERDITE DI CARICO PER ATTRAVERSAMENTO PRESSURE LOSS

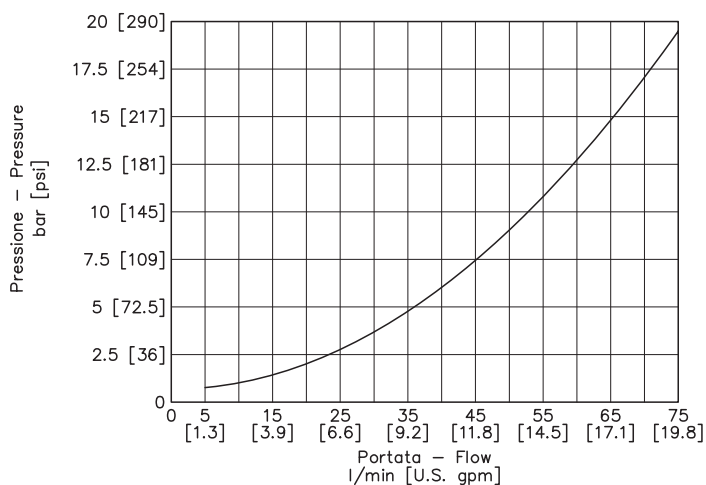

Il diagramma è stato ottenuto con prove eseguite su un numero significativo di motori, utilizzando un olio avente una viscosità cinematica di 37 cSt alla temperatura di 45° C.

Curve according tests carried out with a relevant number of motors and using hydraulic oil with cinematic viscosity of 37 cSt at 45° C temperature.

# CODICI DI ORDINAZIONE ORDERING CODES

Le seguenti lettere o numeri del codice, sono state sviluppate per identificare tutte le configurazioni possibili dei motori BR. Usare il seguente modulo per identificare le caratteristiche desiderate. **Tutte le lettere o numeri del codice devono comparire in fase d'ordine.** Si consiglia di leggere attentamente il catalogo prima di iniziare la compilazione del codice di ordinazione.

The following alphanumeric digits system has been developed to identify all of the configuration options for the BR motors. Use the model code below to specify the desired features. **All alphanumeric digits system of the code must be present when ordering.** We recommend to carefully read the catalogue before filling the ordering code.

## CODICE PRODOTTO / MODEL CODE

1	2	3	4	5	6	7	8	9	10	11	12

### 1 - SERIE / SERIES

BR	Motore orbitale Orbital motor
----	----------------------------------

### 2 - CILINDRATA / DISPLACEMENT

050	50 cm <sup>3</sup> /giro [3.05 in <sup>3</sup> /rev]
065	65 cm <sup>3</sup> /giro [3.965 in <sup>3</sup> /rev]
080	80 cm <sup>3</sup> /giro [4.88 in <sup>3</sup> /rev]
100	100 cm <sup>3</sup> /giro [6.1 in <sup>3</sup> /rev]
130	130 cm <sup>3</sup> /giro [7.93 in <sup>3</sup> /rev]
160	160 cm <sup>3</sup> /giro [9.76 in <sup>3</sup> /rev]
200	200 cm <sup>3</sup> /giro [12.2 in <sup>3</sup> /rev]
250	250 cm <sup>3</sup> /giro [15.25 in <sup>3</sup> /rev]
315	315 cm <sup>3</sup> /giro [19.21 in <sup>3</sup> /rev]
400	400 cm <sup>3</sup> /giro [24.4 in <sup>3</sup> /rev]

### 3 - VERSIONE / VERSION

E	Versione E E Version	
O	Versione O O Version	STANDARD

### 4 - FLANGIA / MOUNTING FLANGE

			VERSIONE / VERSION	
			E	O
2A	Ovale 2 Fori Oval 2 Bolts	STANDARD	•	•
6A	Ovale 6 Fori Oval 6 Bolts		/	•
S4	4 fori 3/8 16 UNC - Ø44,45mm 4 Bolt 3/8 16 UNC - Ø1.75 in	Speciale a richiesta Special on request	/	•

• Disponibile - Available / Non Disponibile - Not Available



1	2	3	4	5	6	7	8	9	10	11	12
---	---	---	---	---	---	---	---	---	----	----	----

### 5 - ESTREMITÀ ALBERO / OUTPUT SHAFT

		VERSIONE / VERSION			
		E	O		
		FLANGIA FLANGE	FLANGIA FLANGE		
		2A	2A	6A	S4
CL250	Albero Cilindrico Ø25 mm 0.97 in Parallel keyed	STANDARD	•	•	•
LC254	Albero Cilindrico Ø25.4 mm 1 in Parallel keyed		•	•	•
C3175	Albero Cilindrico Ø31.75 mm 1.23 in Parallel keyed		/	/	/
CL320	Albero Cilindrico Ø32 mm 1.24 in Parallel keyed		/	/	/
CN320	Albero Conico Tapered Shaft	Speciale a richiesta Special on request	/	/	/
SD250	Albero Scanalato (profilo SAE 6B 1" Z6) Splined Shaft (SAE 6B 1" 6T spline)		•	•	•

• Disponibile - Available / Non Disponibile - Not Available

### 6 - ATTACCO / MAIN PORT

		VERSIONE / VERSION	
		E	O
M08	Attacchi 1/2 G BSPP (40x8) 1/2 G BSPP (40x8) Main Ports	STANDARD	/
R08	Attacchi 1/2 G BSPP (36x36) 1/2 G BSPP (36x36) Main Ports		•

• Disponibile - Available / Non Disponibile - Not Available

### 7 - TENUTA / SEAL

N	NBR	STANDARD
V	FKM	Non disponibile in versione HPS Not available in HPS version

### 8 - VALVOLA / VALVE

		ATTACCO / MAIN PORT	
		M08	R08
XXXX	Senza valvola Without valve	STANDARD	•
M081	Valvola di massima pressione VAF 08 - D VAF 08 - D pressure relief valve		/
M082	Valvola di massima pressione VAF 08 - D/AF VAF 08 - D/AF pressure relief valve		/
M083	Valvola Antiurto e Anticavitazione VAAF 31 VAAF 31 anticavitation and Anti-Shock Valve		/
M084	Valvola con prelievo del fluido in pressione AF AF shuttle-valve		/
M085	Valvola bilanciata di blocco e controllo discesa VCD 08 - S/AF VCD 08 - S/AF overcentre Valve		/
M086	Valvola di controllo bilanciata a doppio effetto VCR1 08 - D/AF VCR1 08 - D/AF double-acting overcentre valve with shuttle valve		/
M087	Valvola di controllo bilanciata a doppio effetto con valvola limitatrice di pressione VCR1 08 D/AF LDP VCR1 08 D/AF LDP double-acting overcentre valve with shuttle valve		/
R081 <sup>(1)</sup>	Valvola di massima pressione VAF E8 - D VAF E8 - D pressure relief valve	/	•
R082 <sup>(1)</sup>	Valvola bilanciata di blocco e controllo discesa VCD E8 - S/AF VCD E8 - S/AF overcentre Valve	/	•
R083 <sup>(1)</sup>	Valvola di controllo bilanciata a doppio effetto VCR1 E8 - D/AF VCR1 E8 - D/AF double-acting overcentre valve with shuttle valve	/	•
R084 <sup>(1)</sup>	Valvola di controllo bilanciata a doppio effetto con valvola limitatrice di pressione VCR1 E8 D/AF LDP VCR1 E8 D/AF LDP double-acting overcentre valve with shuttle valve	/	•

• Disponibile - Available / Non Disponibile - Not Available

(1) Attenzione: quantità minima per ordine 20 pezzi

(1) Warning: minimum quantity for order 20 pieces

1	2	3	4	5	6	7	8	9	10	11	12

### 9 - CARATTERISTICA VERSIONE / VERSION FEATURE

			VALVOLA / VALVE											
			XXXX	M081	M082	M083	M084	M085	M086	M087	R081	R082	R083	R084
000	Nessuna taratura No setting	STANDARD	●	/	/	/	●	/	/	/	/	/	/	/
028	Non Tarata (Campo Taratura 30+70 bar) Not Set [435 to 1015 psi]		/	●	●	/	/	/	/	/	/	/	/	/
017	Non Tarata (Campo Taratura 70+200 bar) Not Set [1015 to 2900 psi]		/	●	●	/	/	/	/	/	/	/	/	/
031	Non Tarata (Campo Taratura 50+130 bar) Not Set [725 to 1885 psi]		/	/	/	●	/	/	/	/	●	/	/	/
021	Non Tarata (Campo Taratura 100+250 bar) Not Set [1450 to 3625 psi]		/	/	/	●	/	/	/	/	/	/	/	/
020	Non Tarata (Campo Taratura 100+200 bar) Not Set [1450 to 2900 psi]		/	/	/	/	/	/	/	/	●	/	/	/
425	Rapporto di Pilotaggio 4.25:1 Pilot Ratio 4.25:1		/	/	/	/	/	/	●	●	/	/	●	●
800	Rapporto di Pilotaggio 8:1 Pilot Ratio 8:1		/	/	/	/	/	/	●	●	/	/	/	/
70D	Rapporto di Pilotaggio 7:1 - Senso di rotazione DX Pilot Ratio 7:1 - Direction of rotation CW		/	/	/	/	/	●	/	/	/	/	/	/
35D	Rapporto di Pilotaggio 3.5:1 - Senso di rotazione DX Pilot Ratio 3.5:1 - Direction of rotation CW		/	/	/	/	/	●	/	/	/	●	/	/
70S	Rapporto di Pilotaggio 7:1 - Senso di rotazione SX Pilot Ratio 7:1 - Direction of rotation CCW		/	/	/	/	/	●	/	/	/	/	/	/
35S	Rapporto di Pilotaggio 3.5:1 - Senso di rotazione SX Pilot Ratio 3.5:1 - Direction of rotation CCW		/	/	/	/	/	●	/	/	/	●	/	/

● Disponibile - Available / / Non Disponibile - Not Available

### 10 - OPZIONE / OPTION

XX	Nessuna Opzione None
----	-------------------------

1	2	3	4	5	6	7	8	9	10	11	12

### 11 - CARATTERISTICA VERSIONE / VERSION FEATURE

			VERSIONE / VERSION	
			E	O
QDR	Versione QUAD-RING con Drenaggio posteriore 1/4 G (BSPP) QUAD-RING version with Rear drain 1/4 G (BSPP)	STANDARD	•	•
HPS	Guarnizione alta pressione (senza Drenaggio posteriore) High Pressure Seal (without Rear Drain)		•	•
DHP	Guarnizione alta pressione su albero primario - Albero secondario CL250 High Pressure Seal on main shaft - Secondary CL250 shaft		/	/
TC1	Tachimetro TAC/U (con predisposizione per sensore) TAC/U tachometer (with sensor arrangement)		•	•
TC4	Tachimetro TAC/M TAC/M tachometer		/	•
TC5	Tachimetro TAC/M-E (con predisposizione per sensore) TAC/M-E tachometer (with sensor arrangement)		/	•
SV0	Versione senza valvole di drenaggio interne + Drenaggio posteriore - 1/4 G (BSPP) Version without built-in check valves + Rear Drain - 1/4 G (BSPP)		•	/
SVH	Versione senza valvole di drenaggio interne + Guarnizione alta pressione (senza Drenaggio posteriore) Version without built-in check valves + High Pressure Seal (without Rear Drain)		•	/
SVA	Versione senza valvole di drenaggio interne + Guarnizione alta pressione + Drenaggio posteriore - 1/4 G (BSPP) Version without built-in check valves + High Pressure Seal + Rear Drain - 1/4 G (BSPP)		•	/
FP0	Freno Brake		/	•
DPM	Guarnizione alta pressione + Drenaggio posteriore - 1/4 G (BSPP) High Pressure Seal + Rear Drain - 1/4 G (BSPP)		•	•

• Disponibile - Available / Non Disponibile - Not Available

### 12 - VERNICIATURA / PAINTING

XX	Non verniciato No painted	STANDARD
01	Verniciato Nero RAL 9005 Black Painted RAL 9005	
02	Verniciato Blu RAL 5015 Blue Painted RAL 5015	
05	Verniciato Grigio RAL 7016 PGrey ainted RAL 7016	
06	Verniciato RAL Grigio 7015 Grey Painted RAL 7015	
22	Verniciato RAL Grigio 7035 Grey Painted RAL 7035	

**Flangia 2A Flange**  
**Attacchi M08 Main ports**

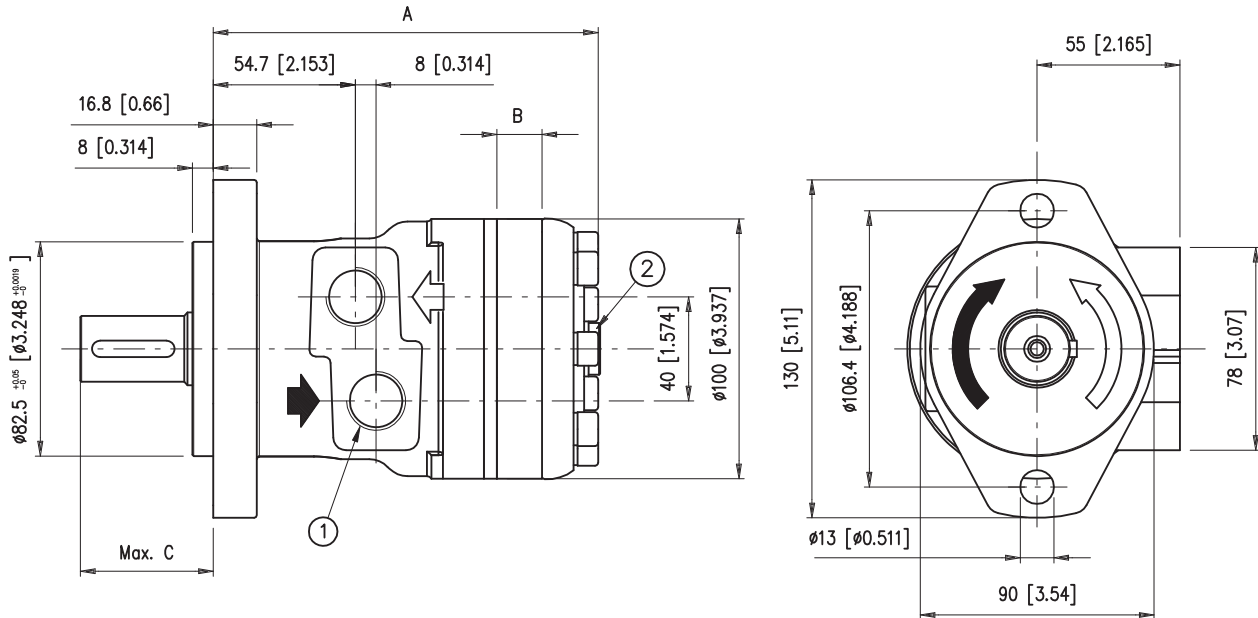

- 1) N° 2 fori di alimentazione 1/2 G (BSPP) profondità filetto 18 mm  
No. 2 1/2 G (BSPP) main ports thread depth 0.70 in
- 2) Drenaggio motore 1/4 G (BSPP) profondità filetto 15 mm Max. Non presente nella versione HPS  
1/4 G (BSPP) drain motor thread depth 0.59 in Max. Not in HPS version.

Per le dimensioni degli alberi vedere pagina E/16  
For shafts dimensions see page E/16

ALBERO SHAFT		CL250	LC254	SD250							
C	mm [in]	54 [2.12]	54 [2.12]	54 [2.12]							

		BR O 050	BR O 065	BR O 080	BR O 100	BR O 130	BR O 160	BR O 200	BR O 250	BR O 315	BR O 400
A	mm [in]	139.5 [5.49]	141.8 [5.58]	144.5 [5.68]	147.7 [5.81]	152.1 [5.98]	158.2 [6.22]	165.3 [6.50]	173.9 [6.84]	185.1 [7.28]	198.4 [7.81]
B	mm [in]	9 [0.354]	11.3 [0.444]	14 [0.551]	17.4 [0.68]	21.8 [0.85]	27.8 [1.09]	34.8 [1.37]	43.5 [1.71]	54.8 [2.15]	68.38 [2.69]
<b>Pesi Weight</b>	<b>kg [lb]</b>	7.2 [15.8]	7.4 [16.3]	7.5 [16.5]	7.7 [16.9]	8 [17.6]	8.3 [18.2]	8.6 [18.9]	9.1 [20]	9.8 [21.5]	10.1 [22.2]

**Flangia 6A Flange**  
**Attacchi M08 Main ports**

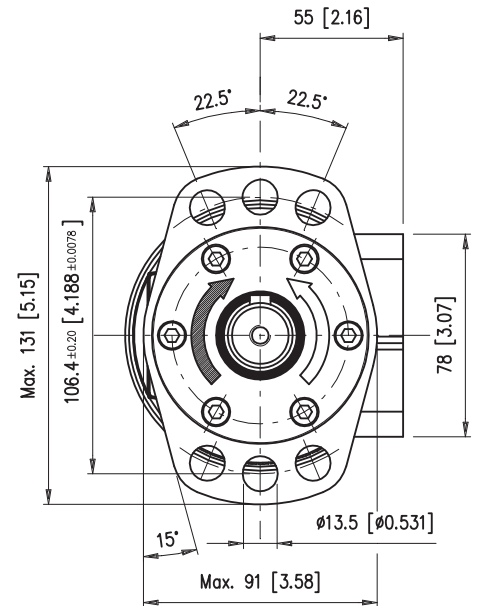
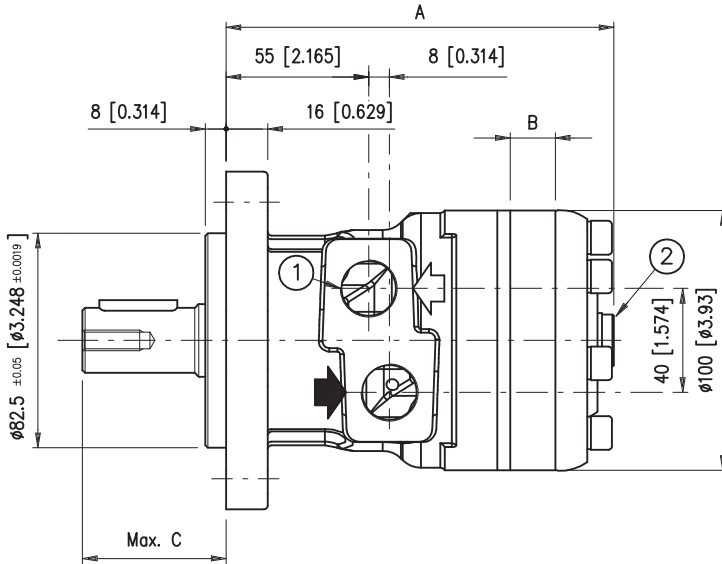

- 1) N° 2 fori di alimentazione 1/2 G (BSPP) profondità filetto 18 mm  
No. 2 1/2 G (BSPP) main ports thread depth 0.70 in
- 2) Drenaggio motore 1/4 G (BSPP) profondità filetto 15 mm.  
1/4 G (BSPP) drain motor thread depth 0.59 in.

Per le dimensioni degli alberi vedere pagina E/16  
For shafts dimensions see page E/16

ALBERO SHAFT		CL250	LC254	SD250	CL320	C3175	CN320				
C	mm [in]	55.3 [2.17]	55.3 [2.17]	55.3 [2.17]	68.3 [2.68]	59.1 [2.32]	68.5 [2.69]				

  

		BR O 050	BR O 065	BR O 080	BR O 100	BR O 130	BR O 160	BR O 200	BR O 250	BR O 315	BR O 400
A	mm [in]	139.5 [5.49]	141.8 [5.58]	144.5 [5.68]	147.7 [5.81]	152.1 [5.98]	158.2 [6.22]	165.3 [6.50]	173.9 [6.84]	185.1 [7.28]	198.4 [7.81]
B	mm [in]	9 [0.354]	11.3 [0.444]	14 [0.551]	17.4 [0.68]	21.8 [0.85]	27.8 [1.09]	34.8 [1.37]	43.5 [1.71]	54.8 [2.15]	68.38 [2.69]
Pesi Weight	kg [lb]	7.3 [16] <sup>1)</sup> 7.4 [16.3]	7.5 [16.5] <sup>1)</sup> 7.6 [16.7]	7.6 [16.7] <sup>1)</sup> 7.7 [16.9]	7.8 [17.1] <sup>1)</sup> 9 [19.8]	8.1 [17.8] <sup>1)</sup> 8.3 [18.2]	8.4 [18.5] <sup>1)</sup> 8.6 [18.9]	8.7 [19.1] <sup>1)</sup> 9 [19.8]	9.2 [20.2] <sup>1)</sup> 9.5 [20.9]	9.9 [21.8] <sup>1)</sup> 10.2 [22.4]	10.2 [22.4] <sup>1)</sup> 10.5 [23.1]

1) I valori si riferiscono alla versione con albero CL250/LC254/SD250 - The values are referred to CL250/LC254/SD250 shaft

**SPECIALE A RICHIESTA - SPECIAL ON REQUEST**

**Flangia S4 Flange**  
**Attacchi M08 Main ports**

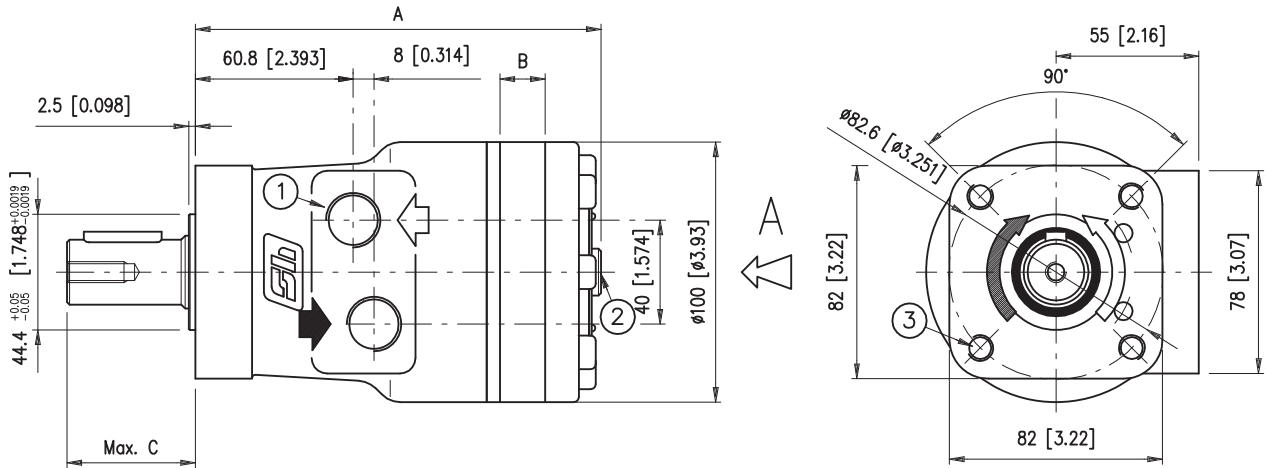

- 1) N° 2 fori di alimentazione 1/2 G (BSPP) profondità filetto 18 mm  
No. 2 1/2 G (BSPP) main ports thread depth 0.70 in
- 2) Drenaggio motore 1/4 G (BSPP) profondità filetto 15 mm.  
1/4 G (BSPP) drain motor thread depth 0.59 in.
- 3) N° 4 3/8" 16 UNC profondità filetto 17 mm  
No. 4 3/8" 16 UNC thread depth 0.66 in

Per le dimensioni degli alberi vedere pagina E/16  
For shafts dimensions see page E/16

ALBERO SHAFT		CL250	LC254	SD250							
C	mm [in]	49.4 [1.94]	49.4 [1.94]	49.4 [1.94]							

		BR O 050	BR O 065	BR O 080	BR O 100	BR O 130	BR O 160	BR O 200	BR O 250	BR O 315	BR O 400
A	mm [in]	147.8 [5.81]	150.1 [5.90]	152.8 [6.01]	156.2 [6.14]	160.6 [6.32]	166.6 [6.55]	173.6 [6.83]	182.3 [7.17]	193.6 [7.62]	207.1 [8.15]
B	mm [in]	9 [0.354]	11.3 [0.444]	14 [0.551]	17.4 [0.68]	21.8 [0.85]	27.8 [1.09]	34.8 [1.37]	43.5 [1.71]	54.8 [2.15]	68.38 [2.69]
Pesi Weight	kg [lb]	7.1 [15.6]	7.3 [16]	7.4 [16.3]	7.6 [16.7]	7.9 [17.4]	8.2 [18]	8.5 [18.7]	9 [19.8]	9.7 [21.3]	10 [22]

**Flangia 2A Flange**  
**Attacchi R08 Main ports**

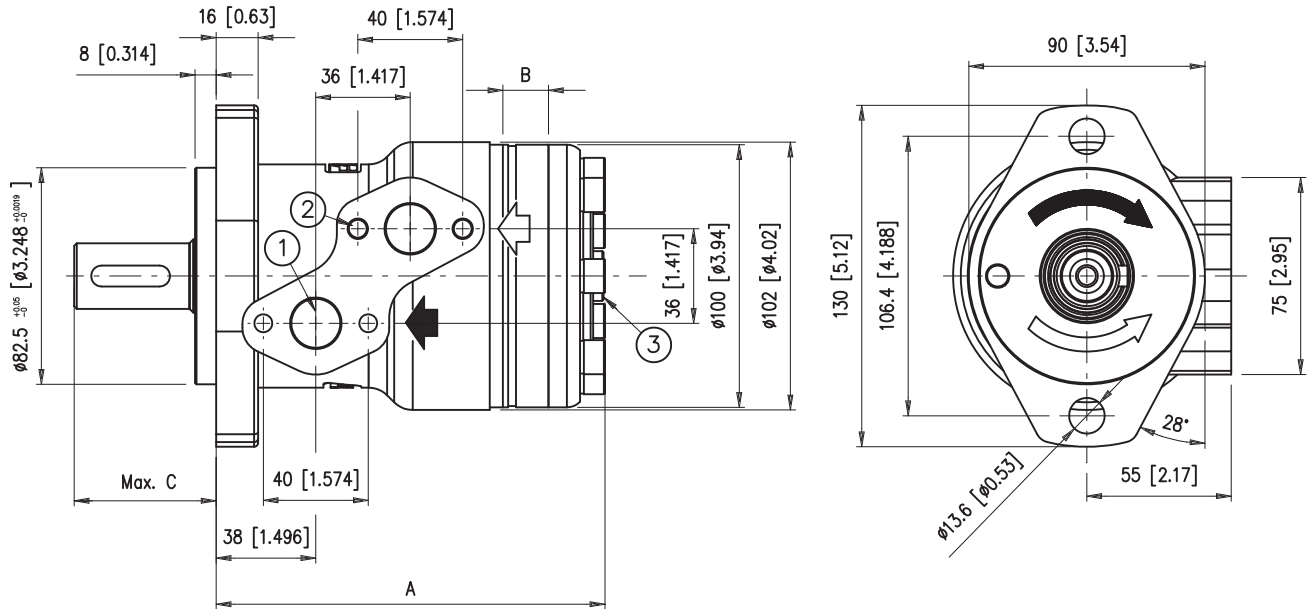

- 1) N° 2 fori di alimentazione 1/4 G (BSPP) profondità filetto 18 mm  
No. 2 1/4 G (BSPP) main ports thread depth 0.70 in
- 2) N° 4 fori M8 tratto utile filetto 15 mm  
No. 4 M8 thread depth 0.59 in
- 3) Drenaggio motore 1/4 G (BSPP) profondità filetto 12 mm (non presente in Versione HPS)  
1/4 G (BSPP) drain motor thread depth 0.472 in (not in HPS version)

Per le dimensioni degli alberi vedere pagina E/16  
For shafts dimensions see page E/16

ALBERO SHAFT		CL250	LC254	SD250							
C	mm [in]	54 [2.12]	54 [2.12]	54 [2.12]							

		BR E 050	BR E 065	BR E 080	BR E 100	BR E 130	BR E 160	BR E 200	BR E 250	BR E 315	BR E 400
A	mm [in]	139.8 [5.50]	142.1 [5.59]	144.8 [5.70]	148.2 [5.83]	152.6 [6.01]	158.6 [6.24]	165.6 [6.52]	174.3 [6.86]	185.6 [7.31]	199.2 [7.84]
B	mm [in]	9 [0.354]	11.3 [0.444]	14 [0.551]	17.4 [0.68]	21.8 [0.85]	27.8 [1.09]	34.8 [1.37]	43.5 [1.71]	54.8 [2.15]	68.38 [2.69]
Peso Weight	kg [lb]	7.2 [15.8]	7.4 [16.3]	7.5 [16.5]	7.7 [16.9]	8 [17.6]	8.3 [18.2]	8.6 [18.9]	9.1 [20]	9.8 [21.5]	10.1 [22.2]

- 1) Drenaggio motore 1/4 G (BSPP) profondità filetto 12 mm  
1/4 G (BSPP) drain motor thread depth 0.472 in
- 2) Attacco sensore M8x1  
Sensor connection M8x1

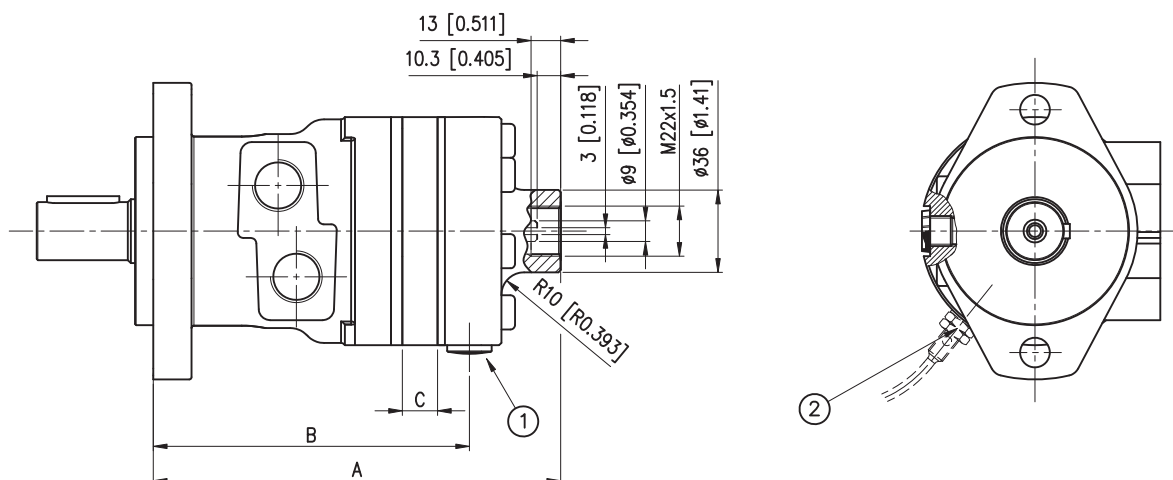

**ATTENZIONE:**

- L'alberino contagiri ha velocità pari a 6 volte quella dell'albero primario del motore e senso di rotazione opposto.
- N.B.: Non sono accettati carichi assiali o radiali sull'albero contagiri. Coppia massima trasmissibile 1 Nm.
- Il motore viene fornito senza il sensore elettronico: se necessario, richiederlo in fase di ordinazione.
- Pressione massima ammessa sulla guarnizione dell'albero contagiri con drenaggio chiuso: 25 bar.

**WARNING:**

- Tacho shaft has a 6 times higher revolution speed than the motor shaft and opposite direction of rotation.
- NOTE: Axial or radial load on tacho shaft must be avoided. Max torque on tacho 1 Nm [0.737 lbf-ft].
- The electronic sensor is not supplied: if required, please state it clearly on order form.
- Max pressure admissible on the shaft seal with closed drain port 25 bar [362.5 psi].

		BR O 050	BR O 065	BR O 080	BR O 100	BR O 130	BR O 160	BR O 200	BR O 250	BR O 315	BR O 400
<b>A</b>	<b>mm [in]</b>	172 [6.77]	174.3 [6.86]	177 [6.96]	180.4 [7.10]	184.8 [7.27]	190.8 [7.51]	197.8 [7.78]	206.5 [8.12]	217.8 [8.57]	231.3 [9.10]
<b>B</b>	<b>mm [in]</b>	132 [5.19]	134.3 [5.28]	137 [5.39]	140.4 [5.52]	144.8 [5.70]	150.8 [5.93]	157.8 [6.21]	166.5 [6.55]	177.8 [7.00]	191.3 [7.53]
<b>C</b>	<b>mm [in]</b>	9 [0.354]	11.3 [0.444]	14 [0.551]	17.4 [0.68]	21.8 [0.85]	27.8 [1.09]	34.8 [1.37]	43.5 [1.71]	54.8 [2.15]	68.38 [2.69]
<b>Pesi Weight</b>	<b>kg [lb]</b>	7.7 [16.9]	7.9 [17.4]	8 [17.6]	8.2 [18]	8.5 [18.7]	8.8 [19.3]	9.1 [20]	9.6 [21.1]	10.3 [22.7]	10.6 [23.3]

**CARATTERISTICHE TECNICHE SENSORE ELETTRONICO**  
**ELECTRONIC SENSOR TECHNICAL FEATURES**

Segnale in uscita versione elettronica  
Output signal electronic tacho

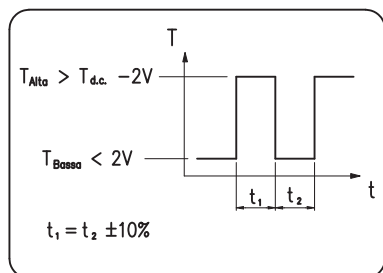

Numero d'impulsi per giro = 90  
Principio di funzionamento induttivo  
Funzione di uscita PNP  
Tensione nominale 10-65 V d.c.  
Caricabilità massima 300 mA  
Frequenza massima 10000 Hz  
Campo di temperatura -25C +85C  
Grado di protezione IP 67

Versioni disponibili:

- Sensore con cavo a tre fili lunghezza 2 metri (cod. 424.0050.0000)
- Sensore con attacco per connettore tipo binder (cod. 424.0060.0000) + connettore tipo binder
- Con cavo a tre fili lunghezza 5 metri (cod. 424.0080.0000)

Number of pulses per revolution = 90  
Inductive principle  
Output current PNP  
Voltage 10-65 V d.c.  
Max load 300 mA  
Max frequency 10000 Hz  
Temperature range -25C +85C  
Enclosure IP 67

Available versions:

- Sensor with 2 metres three wires cable (cod. 424.0050.0000)
- Sensor with binder plug connection (cod. 424.0060.0000) + binder connecting plug with 5 metres three wires cable (cod. 424.0080.0000)



1) Drenaggio motore 1/4 G (BSPP) profondità filetto 13mm  
1/4 G (BSPP) drain motor thread depth 0.511 in

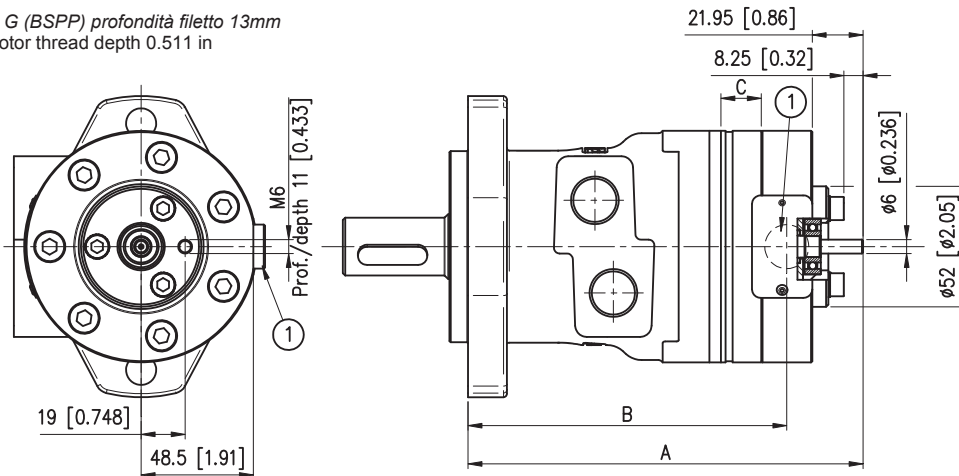

**ATTENZIONE:**

- L'alberino contagiri ha velocità pari a 6 volte quella dell'albero primario del motore e senso di rotazione opposto.
- N.B.: Non sono accettati carichi assiali o radiali sull'albero contagiri.

**WARNING:**

- Tacho shaft has a 6 times higher revolution speed than the motor shaft and opposite direction of rotation.
- NOTE: Axial or radial load on tacho shaft must be avoided.

		BR O 050	BR O 065	BR O 080	BR O 100	BR O 130	BR O 160	BR O 200	BR O 250	BR O 315	BR O 400
<b>A</b>	<b>mm [in]</b>	162.2 [6.38]	164.5 [6.48]	167.2 [6.58]	170.5 [6.71]	175 [6.89]	181 [7.12]	188 [7.40]	196.6 [7.74]	208 [8.19]	221.5 [8.72]
<b>B</b>	<b>mm [in]</b>	129.3 [5.09]	131.6 [5.18]	134.3 [5.29]	137.7 [5.42]	142.1 [5.59]	148.1 [5.83]	155.1 [6.11]	163.8 [6.45]	175.1 [6.89]	188.7 [7.43]
<b>C</b>	<b>mm [in]</b>	9 [0.354]	11.3 [0.444]	14 [0.551]	17.4 [0.68]	21.8 [0.85]	27.8 [1.09]	34.8 [1.37]	43.5 [1.71]	54.8 [2.15]	68.38 [2.69]
<b>Pesi / Weight</b>	<b>kg [lb]</b>	7.7 [16.9]	7.9 [17.4]	8 [17.6]	8.2 [18]	8.5 [18.7]	8.8 [19.3]	9.1 [20]	9.6 [21.1]	10.3 [22.7]	10.6 [23.3]

1) Drenaggio motore 1/4 G (BSPP) profondità filetto 13mm  
1/4 G (BSPP) drain motor thread depth 0.511 in

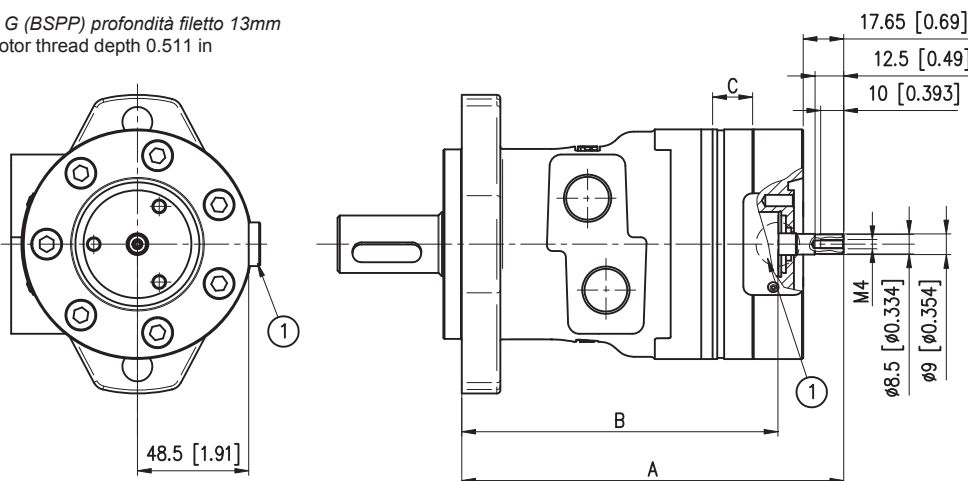

**ATTENZIONE:**

- L'alberino contagiri ha velocità pari a 6 volte quella dell'albero primario del motore e senso di rotazione opposto.
- N.B.: Non sono accettati carichi assiali o radiali sull'albero contagiri.

**WARNING:**

- Tacho shaft has a 6 times higher revolution speed than the motor shaft and opposite direction of rotation.
- NOTE: Axial or radial load on tacho shaft must be avoided.

		BR O 050	BR O 065	BR O 080	BR O 100	BR O 130	BR O 160	BR O 200	BR O 250	BR O 315	BR O 400
<b>A</b>	<b>mm [in]</b>	157.9 [6.21]	160.2 [6.31]	162.9 [6.41]	166.2 [6.54]	170.7 [6.72]	176.7 [6.96]	183.7 [7.23]	192.3 [7.57]	203.7 [8.02]	217.2 [8.55]
<b>B</b>	<b>mm [in]</b>	129.3 [5.09]	131.6 [5.18]	134.3 [5.29]	137.7 [5.42]	142.1 [5.59]	148.1 [5.83]	155.1 [6.11]	163.8 [6.45]	175.1 [6.89]	188.7 [7.43]
<b>C</b>	<b>mm [in]</b>	9 [0.354]	11.3 [0.444]	14 [0.551]	17.4 [0.68]	21.8 [0.85]	27.8 [1.09]	34.8 [1.37]	43.5 [1.71]	54.8 [2.15]	68.38 [2.69]
<b>Pesi / Weight</b>	<b>kg [lb]</b>	7.7 [16.9]	7.9 [17.4]	8 [17.6]	8.2 [18]	8.5 [18.7]	8.8 [19.3]	9.1 [20]	9.6 [21.1]	10.3 [22.7]	10.6 [23.3]

- 1) Comando apertura freno 1/4 G (BSPP) profondità filetto 13mm  
1/4 G (BSPP) brake releasing thread depth 0.511 in
- 2) Drenaggio motore 1/4 G (BSPP) profondità filetto 13mm  
1/4 G (BSPP) drain motor thread depth 0.511 in

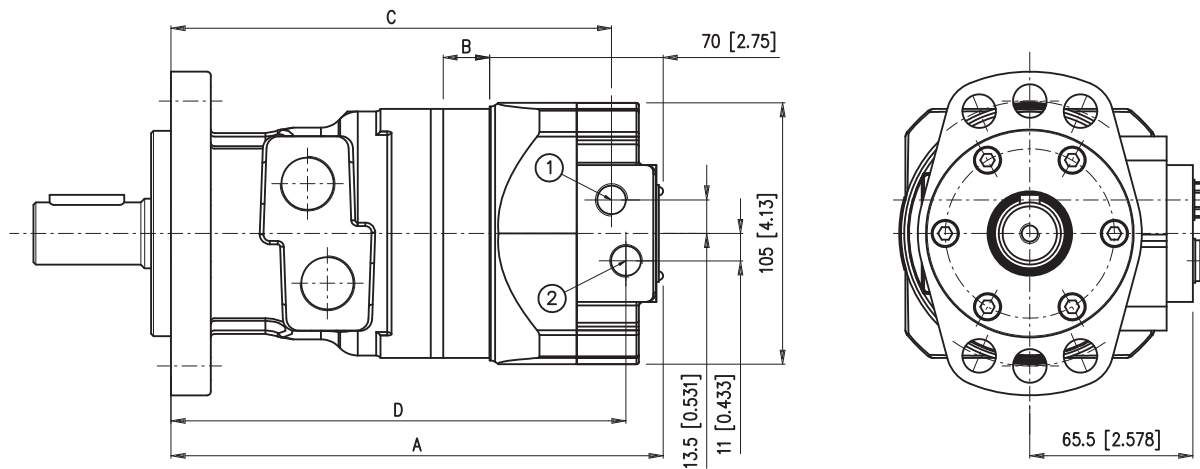

		BR O 050	BR O 065	BR O 080	BR O 100	BR O 130	BR O 160	BR O 200	BR O 250	BR O 315	BR O 400
<b>A</b>	mm [in]	187.9 [7.39]	190.2 [7.48]	192.9 [7.59]	196.3 [7.72]	200.7 [7.90]	206.7 [8.13]	213.7 [8.41]	222.4 [8.75]	233.7 [9.20]	247.2 [9.73]
<b>B</b>	mm [in]	9 [0.354]	11.3 [0.444]	14 [0.551]	17.4 [0.68]	21.8 [0.85]	27.8 [1.09]	34.8 [1.37]	43.5 [1.71]	54.8 [2.15]	68.38 [2.69]
<b>C</b>	mm [in]	169.9 [6.68]	172.2 [6.77]	174.9 [6.88]	178.3 [7.01]	182.7 [7.19]	188.7 [7.42]	195.7 [7.70]	204.4 [8.04]	215.7 [8.49]	229.2 [9.02]
<b>D</b>	mm [in]	173 [6.81]	175.3 [6.90]	178 [7.00]	181.4 [7.14]	185.8 [7.31]	191.8 [7.55]	198.8 [7.82]	207.5 [8.16]	218.8 [8.61]	232.2 [9.14]
<b>Pesi Weight</b>	kg [lb]	8.2 [18]	8.4 [18.5]	8.5 [18.7]	8.7 [19.1]	9 [19.8]	9.3 [20.4]	9.6 [21.1]	10.1 [22.2]	10.8 [23.8]	11.1 [24.4]

**CARATTERISTICHE FRENO**  
**BRAKE FEATURES**

*I freni integrati nei motori FP sono freni di stazionamento a sbloccaggio idraulico (freni negativi) e non possono essere impiegati per frenare dinamicamente il carico.*

The brakes integrated in FP motors are holding brakes type (negative brake) and cannot be used for dynamic braking action.

**Accorgimenti per l'installazione**

**Installation layout**

- Il motore idraulico con freno posteriore FP richiede obbligatoriamente il collegamento del drenaggio motore, posto sul corpo freno, in serbatoio a scarico libero.
- Nel caso di funzionamento in circuito aperto è consigliato l'utilizzo di una valvola di ritardo chiusura freno ( per evitare il funzionamento dinamico dello stesso) di una valvola overcentre e di un distributore a centro aperto.

- The FP hydraulic motors must always have the drain port (on casing) directly connected with tank
- If open circuit layout is needed, it is advisable to use a flow control valve on brake piston ports (in order to avoid dynamic braking), on overcentre valve and a open-centre directional valve.

Caratteristiche del motore-freno		Motor-brake features
Pressione di apertura minima	22 bar [319 psi]	Minim release pressure
Pressione di freno libero	25 bar [362.5 psi]	Complete brake release pressure
Pressione massima sul freno	160 bar [2320 psi]	Max. brake pressure
Coppia massimastatica	370 Nm [272.7 lbf-ft]	Max. static torque
Velocità massima motore	350 rpm	Max. motor speed

**ALBERO CILINDRICO CL250**  
CL250 CYLINDRICAL SHAFT

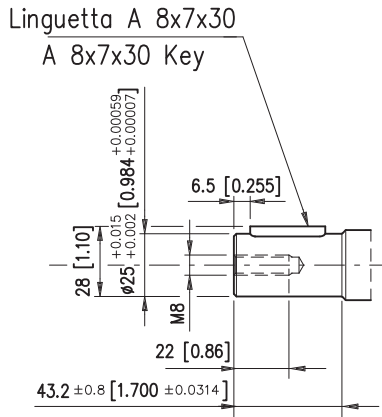

**ALBERO CILINDRICO LC254**  
LC254 CYLINDRICAL SHAFT

Linguetta A 1/4"x1/4"x1 1/4" BS46  
A 1/4"x1/4"x1 1/4" BS46 Key

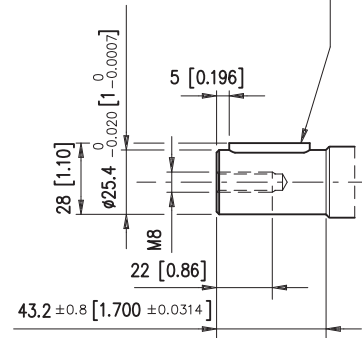

**ALBERO SCANALATO SD250**  
SD250 SPLINED SHAFT

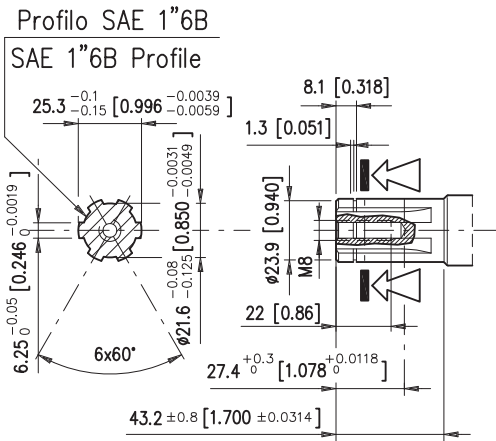

**ALBERO CILINDRICO CL320**  
CL320 CYLINDRICAL SHAFT

Linguetta A 10x8x40  
A 10x8x40 Key

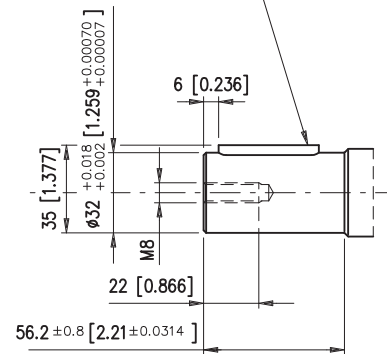

**ALBERO CILINDRICO C3175**  
C3175 CYLINDRICAL SHAFT

Linguetta A 5/16x5/16x1.1/4 UNI 6604  
A 5/16x5/16x1.1/4 Key

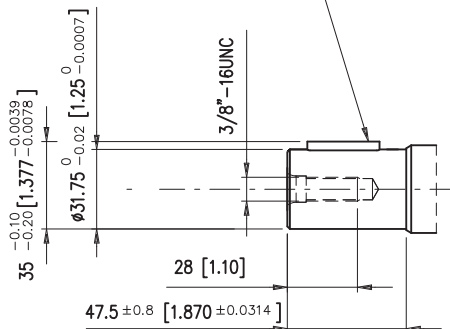

**ALBERO CONICO CN320**  
CN320 TAPERED SHAFT

Linguetta 6x9 UNI 6606-69  
6x9 UNI 6606-69 key

Conicità' 1:10  
1:10 taper

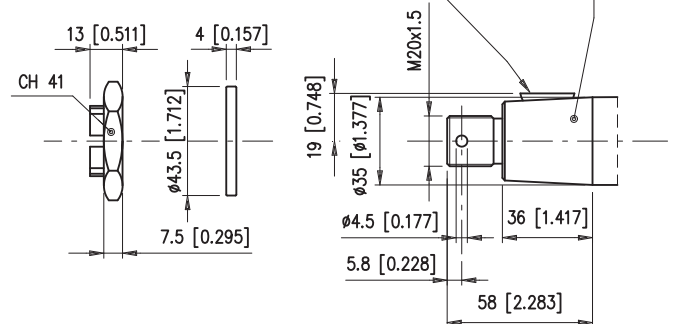

# CARICHI AMMESSI SULL'ALBERO SHAFT LOAD CAPACITY

I carichi ammessi sull'albero variano in funzione di:

- Velocità (n)
- Distanza (L) dal punto di applicazione del carico alla flangia di montaggio
- Versione della flangia di montaggio
- Versione dell'albero

Formula utilizzabile per il calcolo del carico radiale (Pr) ai vari numeri di giri (n), e alle varie distanze (L) dalla flangia tipo "2A" ovale 2 fori e "6A" ovale 6 fori.

Radial load capacity (Pr) curve according to speed (n) and distance (L) from flange, valid for the 2-bolt flange type "2A" and 6-bolt flange type "6A"

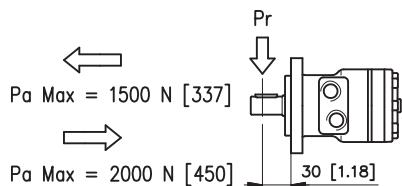

	Flangia / Flange 2A	Flangia / Flange 6A
alberi / shafts CL250 LC254 SD250	$Pr = \frac{800}{n} \cdot \frac{250000}{95 + L}$ [N]	$Pr = \frac{800}{n} \cdot \frac{250000}{95 + L}$ [N]
alberi / shafts C3175 CL320 CN320		$Pr = \frac{800}{n} \cdot \frac{187500}{95 + L}$ [N]

Formula valida per  $n \geq 200$  rpm  
Per  $n < 200$  rpm  $P_{rmax} = 8000$  N

This formula being valid for  $n \geq 200$  rpm  
For  $n < 200$  rpm  $P_{rmax} = 8000$  N [1800 lbf]

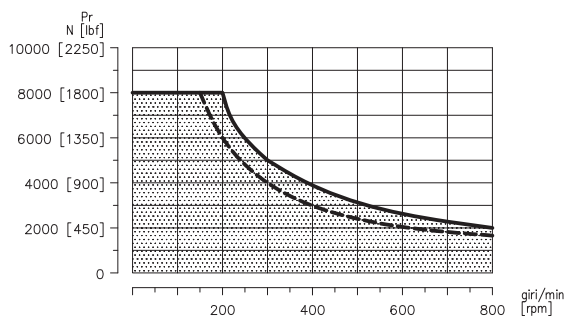

The permissible radial shaft load depends on

- Speed (n)
- Distance (L) from the point of load to the mounting flange
- Mounting flange version
- Shaft version

Formula utilizzabile per il calcolo del carico radiale (Pr) ai vari numeri di giri (n), e alle varie distanze (L) dalla flangia tipo "S4" 4 fori.

Radial load capacity (Pr) curve according to speed (n) and distance (L) from flange, valid for the 4-bolt flange type "S4".

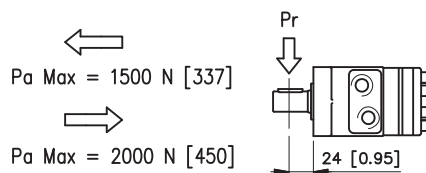

	Flangia / Flange S4
alberi / shafts CL250 LC254 SD250	$Pr = \frac{800}{n} \cdot \frac{242000}{97 + L}$ [N]

Formula valida per  $n \geq 200$  rpm  
Per  $n < 200$  rpm  $P_{rmax} = 8000$  N

This formula being valid for  $n \geq 200$  rpm  
For  $n < 200$  rpm  $P_{rmax} = 8000$  N [1800 lbf]

La curva mostra la relazione tra (Pr) e (n) quando:

- $L = 30$  mm [1.18 in] per motori flangia 2A e 6A
- $L = 24$  mm [0.95 in] per motori flangia S4

The curve show the relation between (Pr) and (n)

- $L = 30$  mm [1.18 in] for motors with 2A and 6A flange
- $L = 24$  mm [0.95 in] for motors with S4 flange

--- Per alberi C3175-CL320-CN320  
For shafts C3175-CL320-CN320  
— Per alberi CL250-LC254-SD250  
For shafts CL250-LC254-SD250

## DATI TECNICI PER MOTORE BS CON ALBERO CILINDRICO CL254 BS MOTOR TECHNICAL DATA WITH CL254 PARALLEL KEYS SHAFT

Motore Motor	Cilindrata Displacement	Pressione Max ingresso Max. input pressure		Pressione diff. max. Max.differential pressure		Coppia max. Max. torque		Portata max. Max. flow		Velocità max. Max. speed		Potenza max. Max. power	
	cm <sup>3</sup> /rev [in <sup>3</sup> /rev]	bar [psi]		bar [psi]		Nm [lbf-ft]		l/min [U.S. gpm]		giri/min [rpm]		kW [hp]	
<b>BS 050</b>	51.6 [3.14]	Cont	175 [2537]	Cont	140 [2030]	Cont	103 [75.9]	Cont	40 [10.6]	Cont	775	Cont	6.8 [9.1]
		Int <sup>1)</sup>	200 [2900]	Int <sup>1)</sup>	175 [2540]	Int <sup>1)</sup>	126 [92.8]	Int <sup>1)</sup>	50 [13.2]	Int <sup>1)</sup>	969	Int <sup>1)</sup>	8.4 [11.2]
<b>BS 065</b>	64.9 [3.95]	Cont	175 [2537]	Cont	150 [2175]	Cont	140 [103.1]	Cont	50 [13.2]	Cont	770	Cont	9.2 [12.3]
		Int <sup>1)</sup>	200 [2900]	Int <sup>1)</sup>	185 [2682]	Int <sup>1)</sup>	166 [122.3]	Int <sup>1)</sup>	60 [15.9]	Int <sup>1)</sup>	924	Int <sup>1)</sup>	10.6 [14.2]
<b>BS 080</b>	80.4 [4.9]	Cont	175 [2537]	Cont	175 [2537]	Cont	197 [145.1]	Cont	60 [15.9]	Cont	746	Cont	13 [17.4]
		Int <sup>1)</sup>	200 [2900]	Int*	200 [2900]	Int*	218 [160.6]	Int <sup>1)</sup>	75 [19.8]	Int <sup>1)</sup>	933	Int <sup>1)</sup>	15 [20.1]
<b>BS 100</b>	100 [6.1]	Cont	175 [2537]	Cont	175 [2537]	Cont	237 [174.6]	Cont	60 [15.9]	Cont	600	Cont	13 [17.4]
		Int <sup>1)</sup>	200 [2900]	Int <sup>1)</sup>	200 [2900]	Int <sup>1)</sup>	277 [204.1]	Int <sup>1)</sup>	75 [19.8]	Int <sup>1)</sup>	750	Int <sup>1)</sup>	15 [20.1]
<b>BS 130</b>	125.7 [7.66]	Cont	175 [2537]	Cont	175 [2537]	Cont	300 [221.1]	Cont	60 [15.9]	Cont	477	Cont	12.5 [16.8]
		Int <sup>1)</sup>	200 [2900]	Int <sup>1)</sup>	200 [2900]	Int <sup>1)</sup>	340 [250.5]	Int <sup>1)</sup>	75 [19.8]	Int <sup>1)</sup>	597	Int <sup>1)</sup>	14.5 [19.4]
<b>BS 160</b>	160 [9.76]	Cont	175 [2537]	Cont	140 [2030]	Cont	296 [218.1]	Cont	60 [15.9]	Cont	375	Cont	10 [13.4]
		Int <sup>1)</sup>	200 [2900]	Int <sup>1)</sup>	175 [2540]	Int <sup>1)</sup>	375 [276.3]	Int <sup>1)</sup>	75 [19.8]	Int <sup>1)</sup>	469	Int <sup>1)</sup>	12.5 [16.8]
<b>BS 200</b>	200 [12.2]	Cont	175 [2537]	Cont	115 [1667]	Cont	297 [218.8]	Cont	60 [15.9]	Cont	300	Cont	8.5 [11]
		Int <sup>1)</sup>	200 [2900]	Int <sup>1)</sup>	140 [2030]	Int <sup>1)</sup>	380 [280]	Int <sup>1)</sup>	75 [19.8]	Int <sup>1)</sup>	375	Int <sup>1)</sup>	10 [13.4]
<b>BS 250</b>	250 [15.2]	Cont	175 [2537]	Cont	90 [1305]	Cont	297 [218.8]	Cont	60 [15.9]	Cont	240	Cont	7.1 [9.5]
		Int <sup>1)</sup>	200 [2900]	Int <sup>1)</sup>	120 [1740]	Int <sup>1)</sup>	377 [277.8]	Int <sup>1)</sup>	75 [19.8]	Int <sup>1)</sup>	300	Int <sup>1)</sup>	8.5 [11]
<b>BS 315</b>	314.5 [19.1]	Cont	175 [2537]	Cont	70 [1020]	Cont	300 [221.1]	Cont	60 [15.9]	Cont	191	Cont	5 [6.7]
		Int <sup>1)</sup>	200 [2900]	Int <sup>1)</sup>	100 [1450]	Int <sup>1)</sup>	420 [309.5]	Int <sup>1)</sup>	75 [19.8]	Int <sup>1)</sup>	238	Int <sup>1)</sup>	6.6 [8.8]
<b>BS 400</b>	393 [23.9]	Cont	175 [2537]	Cont	55 [800]	Cont	292 [215.2]	Cont	60 [15.9]	Cont	153	Cont	4.1 [5.4]
		Int <sup>1)</sup>	200 [2900]	Int <sup>1)</sup>	85 [1230]	Int <sup>1)</sup>	425 [313.2]	Int <sup>1)</sup>	75 [19.8]	Int <sup>1)</sup>	191	Int <sup>1)</sup>	6.1 [8.1]
<b>BS 400</b>	393 [23.9]	Peak <sup>2)</sup>	225 [3262]	Peak <sup>2)</sup>	175 [2537]	Peak <sup>2)</sup>	175 [2537]	Peak <sup>2)</sup>	175 [2537]	Peak <sup>2)</sup>	225 [3262]	Peak <sup>2)</sup>	225 [3262]

## DATI TECNICI PER MOTORE BS CON ALBERO SCANALATO SE250 BS MOTOR TECHNICAL DATA WITH SE250 SPLINED SHAFT

Motore Motor	Cilindrata Displacement	Pressione max ingresso Max. input pressure		Pressione diff. max. Max.differential pressure		Coppia max. Max. torque		Portata max. Max. flow		Velocità max. Max. speed		Potenza max. Max. power	
	cm <sup>3</sup> /rev [in <sup>3</sup> /rev]	bar [psi]		bar [psi]		Nm [lbf-ft]		l/min [U.S. gpm]		giri/min [rpm]		kW [hp]	
<b>BS 050</b>	51.6 [3.14]	Cont	175 [2537]	Cont	140 [2030]	Cont	103 [75.9]	Cont	40 [10.6]	Cont	775	Cont	6.8 [9.1]
		Int <sup>1)</sup>	200 [2900]	Int <sup>1)</sup>	175 [2540]	Int <sup>1)</sup>	126 [92.8]	Int <sup>1)</sup>	50 [13.2]	Int <sup>1)</sup>	969	Int <sup>1)</sup>	8.4 [11.2]
<b>BS 065</b>	64.9 [3.95]	Cont	175 [2537]	Cont	150 [2175]	Cont	140 [103.1]	Cont	50 [13.2]	Cont	770	Cont	9.2 [12.3]
		Int <sup>1)</sup>	200 [2900]	Int <sup>1)</sup>	185 [2682]	Int <sup>1)</sup>	166 [122.3]	Int <sup>1)</sup>	60 [15.9]	Int <sup>1)</sup>	924	Int <sup>1)</sup>	10.6 [14.2]
<b>BS 080</b>	80.4 [4.9]	Cont	175 [2537]	Cont	175 [2537]	Cont	197 [145.1]	Cont	60 [15.9]	Cont	746	Cont	13 [17.4]
		Int <sup>1)</sup>	200 [2900]	Int*	200 [2900]	Int*	218 [160.6]	Int <sup>1)</sup>	75 [19.8]	Int <sup>1)</sup>	933	Int <sup>1)</sup>	15 [20.1]
<b>BS 100</b>	100 [6.1]	Cont	175 [2537]	Cont	175 [2537]	Cont	237 [174.6]	Cont	60 [15.9]	Cont	600	Cont	13 [17.4]
		Int <sup>1)</sup>	200 [2900]	Int <sup>1)</sup>	200 [2900]	Int <sup>1)</sup>	277 [204.1]	Int <sup>1)</sup>	75 [19.8]	Int <sup>1)</sup>	750	Int <sup>1)</sup>	15 [20.1]
<b>BS 130</b>	125.7 [7.66]	Cont	175 [2537]	Cont	175 [2537]	Cont	300 [221.1]	Cont	60 [15.9]	Cont	477	Cont	12.5 [16.8]
		Int <sup>1)</sup>	200 [2900]	Int <sup>1)</sup>	200 [2900]	Int <sup>1)</sup>	340 [250.5]	Int <sup>1)</sup>	75 [19.8]	Int <sup>1)</sup>	597	Int <sup>1)</sup>	14.5 [19.4]
<b>BS 160</b>	160 [9.76]	Cont	175 [2537]	Cont	165 [2390]	Cont	350 [257.9]	Cont	60 [15.9]	Cont	375	Cont	11.8 [15.8]
		Int <sup>1)</sup>	200 [2900]	Int <sup>1)</sup>	200 [2900]	Int <sup>1)</sup>	428 [315.4]	Int <sup>1)</sup>	75 [19.8]	Int <sup>1)</sup>	469	Int <sup>1)</sup>	14.3 [19.1]
<b>BS 200</b>	200 [12.2]	Cont	175 [2537]	Cont	130 [1890]	Cont	335 [246.8]	Cont	60 [15.9]	Cont	300	Cont	9.7 [12.9]
		Int <sup>1)</sup>	200 [2900]	Int <sup>1)</sup>	165 [2390]	Int <sup>1)</sup>	446 [328.7]	Int <sup>1)</sup>	75 [19.8]	Int <sup>1)</sup>	375	Int <sup>1)</sup>	12 [16]
<b>BS 250</b>	250 [15.2]	Cont	175 [2537]	Cont	105 [1522]	Cont	347 [255.7]	Cont	60 [15.9]	Cont	240	Cont	8.3 [11.1]
		Int <sup>1)</sup>	200 [2900]	Int <sup>1)</sup>	135 [1957]	Int <sup>1)</sup>	424 [312.4]	Int <sup>1)</sup>	75 [19.8]	Int <sup>1)</sup>	300	Int <sup>1)</sup>	9.6 [12.8]
<b>BS 315</b>	314.5 [19.1]	Cont	175 [2537]	Cont	85 [1232]	Cont	362 [266.7]	Cont	60 [15.9]	Cont	191	Cont	6 [8]
		Int <sup>1)</sup>	200 [2900]	Int <sup>1)</sup>	115 [1670]	Int <sup>1)</sup>	484 [356.7]	Int <sup>1)</sup>	75 [19.8]	Int <sup>1)</sup>	238	Int <sup>1)</sup>	7.6 [10.1]
<b>BS 400</b>	393 [23.9]	Cont	175 [2537]	Cont	65 [942]	Cont	345 [254.2]	Cont	60 [15.9]	Cont	153	Cont	4.9 [6.5]
		Int <sup>1)</sup>	200 [2900]	Int <sup>1)</sup>	90 [1310]	Int <sup>1)</sup>	450 [331.6]	Int <sup>1)</sup>	75 [19.8]	Int <sup>1)</sup>	191	Int <sup>1)</sup>	6.5 [8.7]
<b>BS 400</b>	393 [23.9]	Peak <sup>2)</sup>	225 [3262]	Peak <sup>2)</sup>	175 [2537]	Peak <sup>2)</sup>	175 [2537]	Peak <sup>2)</sup>	175 [2537]	Peak <sup>2)</sup>	225 [3262]	Peak <sup>2)</sup>	225 [3262]

1) Le condizioni intermittenti non devono durare più del 10% di ogni minuto. Intermittent duty must not exceed 10% every minute.

2) Le condizioni di picco non devono durare più del 1% di ogni minuto. Peak duty must not exceed 1% of every minute.

Pressione massima di scarico senza drenaggio o massima pressione nella linea di drenaggio. I motori sono forniti nella versione con guarnizioni standard (diagramma Standard) o nella versione con guarnizioni ad alta pressione (diagramma HPS). Per condizioni di pressione e velocità non contemplate dal presente grafico si consiglia di contattare la Brevini Fluid Power.

Max. return pressure without drain line or max. pressure in the drain line. Motor are supplied in standard seal version (Standard chart) or in HPS seal version (HPS chart). For pressure and speeds not showed in the curve below, please contact Brevini Fluid Power.

STANDARD (QDR)

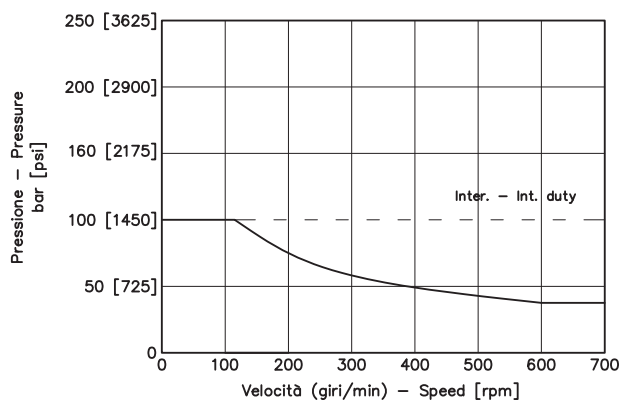

HPS

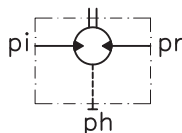
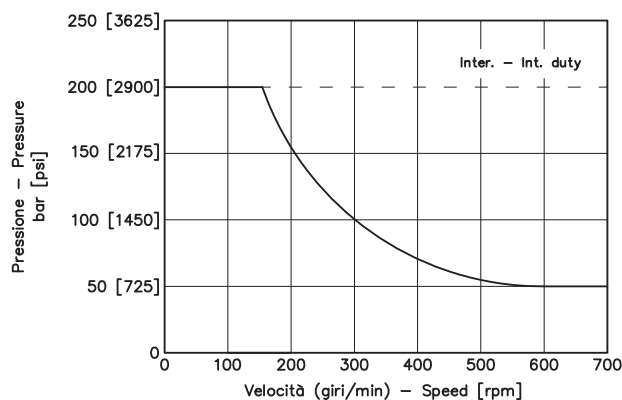

$$Ph = \frac{pi + pr}{2} [bar]$$

*ph* = pressione in carcassa  
*pi* = pressione di alimentazione  
*pr* = pressione di scarico

ph = housing pressure  
pi = inlet pressure  
pr = outlet pressure

- La pressione in carcassa senza drenaggio è data dalla media tra *pi* e *pr*.
- Il motore BS è fornito con drenaggio (STANDARD)
- La massima pressione di scarico con drenaggio è di 175 bar

- The case pressure without drain line is the average between inlet and return pressure.
- As standard, BS motors are supplied with drain port (STANDARD).
- Max. permissible return (back) pressure with drain line 175 bar [2540 psi]

Le seguenti lettere o numeri del codice, sono state sviluppate per identificare tutte le configurazioni possibili dei motori BS. Usare il seguente modulo per identificare le caratteristiche desiderate. **Tutte le lettere o numeri del codice devono comparire in fase d'ordine.** Si consiglia di leggere attentamente il catalogo prima di iniziare la compilazione del codice di ordinazione.

The following alphanumeric digits system has been developed to identify all of the configuration options for the BS motors. Use the model code below to specify the desired features. **All alphanumeric digits system of the code must be present when ordering.** We recommend to carefully read the catalogue before filling the ordering code.

**CODICE PRODOTTO / MODEL CODE**

1	2	3	4	5	6	7	8	9	10	11	12

**1 - SERIE / SERIES**

BS	Motore orbitale Orbital motor
----	----------------------------------

**2 - CILINDRATA / DISPLACEMENT**

050	50 cm <sup>3</sup> /giro [3.05 in <sup>3</sup> /rev]
065	65 cm <sup>3</sup> /giro [3.965 in <sup>3</sup> /rev]
080	80 cm <sup>3</sup> /giro [4.88 in <sup>3</sup> /rev]
100	100 cm <sup>3</sup> /giro [6.1 in <sup>3</sup> /rev]
130	130 cm <sup>3</sup> /giro [7.93 in <sup>3</sup> /rev]
160	160 cm <sup>3</sup> /giro [9.76 in <sup>3</sup> /rev]
200	200 cm <sup>3</sup> /giro [12.2 in <sup>3</sup> /rev]
250	250 cm <sup>3</sup> /giro [15.25 in <sup>3</sup> /rev]
315	315 cm <sup>3</sup> /giro [19.21 in <sup>3</sup> /rev]
400	400 cm <sup>3</sup> /giro [24.4 in <sup>3</sup> /rev]

**3 - VERSIONIE / VERSION**

O	Versione O O Version
---	-------------------------

**4 - FLANGIA / MOUNTING FLANGE**

6A	Ovale 6 Fori Oval 6 Bolts	STANDARD
S4	4 fori 3/8 16 UNC - Ø44,45mm 4 Bolt 3/8 16 UNC - Ø1.75 in	

**5 - ESTREMITÀ ALBERO / OUTPUT SHAFT**

CL254	Albero Cilindrico Ø25.4 mm 1 in Parallel keyed	STANDARD
SE250	Albero Scanalato (profilo SAE 6B 1" Z6) Splined Shaft (SAE 6B 1" 6T spline)	
SE210	Albero Scanalato (profilo ANSI-B92.1a-1976-16/32 Z13) Splined Shaft (ANSI-B92.1a-1976-16/32 13T spline)	Speciale a richiesta Special on request

1	2	3	4	5	6	7	8	9	10	11	12

### 6 - ATTACCO / MAIN PORT

S08	Attacchi 7/8" - 14 UNF SAE10 7/8" - 14 UNF SAE10 Main Ports	STANDARD
SS8	Attacchi 1/2" - 14 NPTF 1/2" - 14 NPTF Main Ports	
BFL	Attacchi Manifold Manifold Main Ports	
MS8	Attacchi 1/2 G BSPP 1/2 G BSPP (Main Ports)	

### 7 - TENUTA / SEAL

N	NBR	
---	-----	--

### 8 - VALVOLA / VALVE

XXXX	Non Richieste Not Required	STANDARD
------	-------------------------------	----------

### 9 - CARATTERISTICA VALVOLA / VALVE FEATURE

000	Caratteristica non necessaria Feature not necessary	STANDARD
-----	--	----------

### 10 - OPZIONE / OPTION

XX	Nessuna Opzione None	
----	-------------------------	--

### 11 - CARATTERISTICA VERSIONE / VERSION FEATURE

HPS	Guarnizione Alta Pressione (senza Drenaggio posteriore) High Pressure Seal (without Rear drain)
QDR	Versione QUAD-RING con Drenaggio posteriore 1/4 G (BSPP) QUAD-RING Version with Rear drain 1/4 G (BSPP)
QDS	Versione QUAD-RING con Drenaggio posteriore 7/16" 20UNF2B QUAD-RING Version with Rear drain 7/16" 20UNF2B
DPS	Guarnizione alta pressione con Drenaggio posteriore 7/16" 20UNF2B High Pressure Seal with Rear drain 7/16" 20UNF2B
DPM	Guarnizione alta pressione con Drenaggio posteriore 1/4 G (BSPP) High Pressure Seal with Rear drain 1/4 G (BSPP)

### 12 - VERNICIATURA / PAINTING

XX	Non verniciato Not Painted
01	Verniciato Nero RAL 9005 Black Painted RAL 9005



**Flangia S4 Flange**

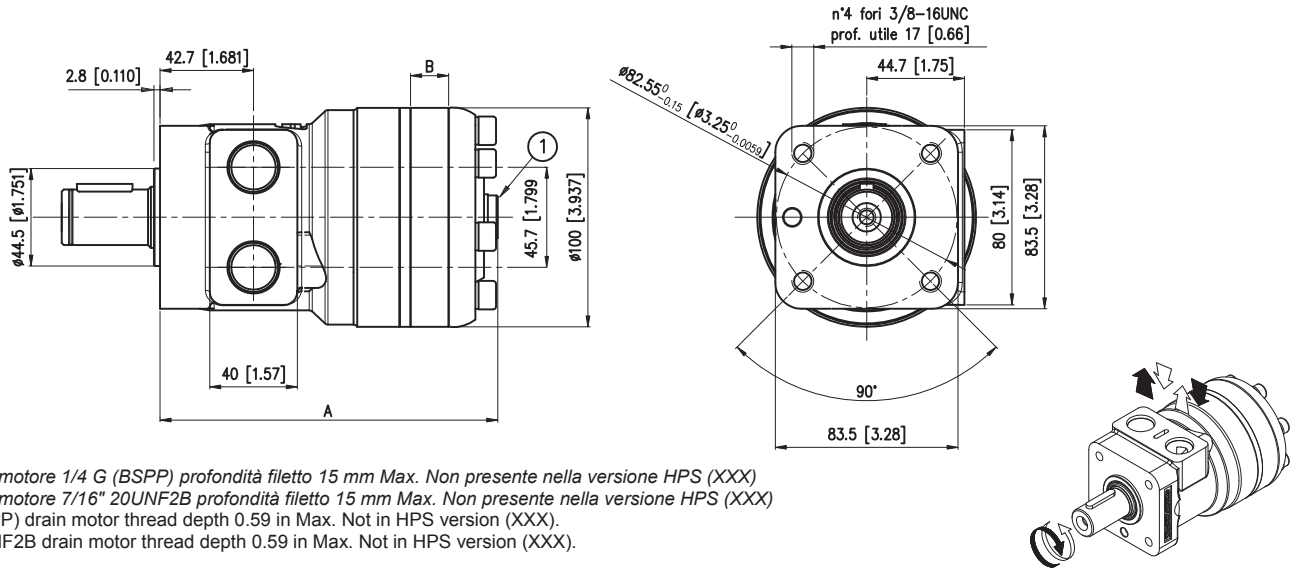

- 1) Drenaggio motore 1/4 G (BSPP) profondità filetto 15 mm Max. Non presente nella versione HPS (XXX)  
Drenaggio motore 7/16" 20UNF2B profondità filetto 15 mm Max. Non presente nella versione HPS (XXX)  
1/4 G (BSPP) drain motor thread depth 0.59 in Max. Not in HPS version (XXX).  
7/16" 20UNF2B drain motor thread depth 0.59 in Max. Not in HPS version (XXX).

		BS 050	BS 065	BS 080	BS 100	BS 130	BS 160	BS 200	BS 250	BS 315	BS 400
<b>A</b>	<b>mm [in]</b>	145 [5.70]	147.3 [5.79]	150 [5.90]	153.5 [6.04]	158 [6.22]	164 [6.45]	171 [6.73]	179.5 [7.06]	191 [7.51]	204.5 [8.05]
<b>B</b>	<b>mm [in]</b>	9 [0.354]	11.3 [0.444]	14 [0.551]	17.4 [0.68]	21.8 [0.85]	27.8 [1.09]	34.8 [1.37]	43.5 [1.71]	54.8 [2.15]	68.38 [2.69]
<b>Pesi Weight</b>	<b>kg [lb]</b>	6.8 [14.96]	7 [15.42]	7.1 [15.62]	7.4 [16.28]	7.7 [16.94]	8 [17.6]	8.4 [18.48]	8.9 [19.58]	9.6 [21.12]	9.9 [21.78]

**Flangia 6A Flange**

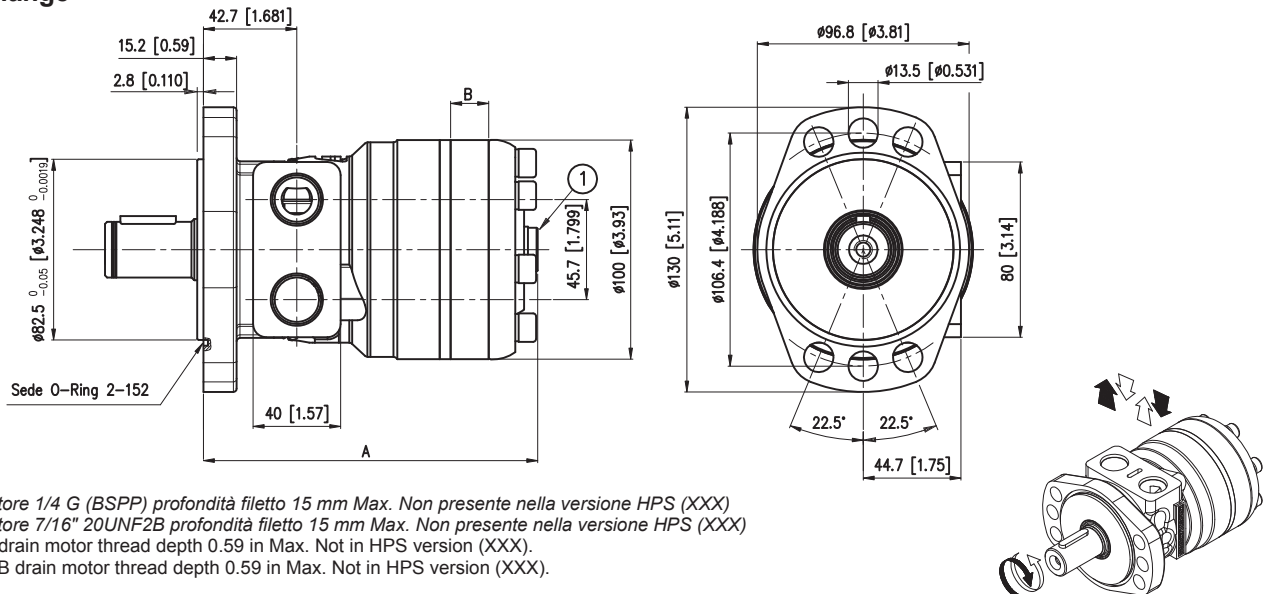

- 1) Drenaggio motore 1/4 G (BSPP) profondità filetto 15 mm Max. Non presente nella versione HPS (XXX)  
Drenaggio motore 7/16" 20UNF2B profondità filetto 15 mm Max. Non presente nella versione HPS (XXX)  
1/4 G (BSPP) drain motor thread depth 0.59 in Max. Not in HPS version (XXX).  
7/16" 20UNF2B drain motor thread depth 0.59 in Max. Not in HPS version (XXX).

		BS 050	BS 065	BS 080	BS 100	BS 130	BS 160	BS 200	BS 250	BS 315	BS 400
<b>A</b>	<b>mm [in]</b>	143.7 [5.65]	146 [5.74]	148.7 [5.85]	152.1 [5.98]	156.5 [6.16]	162.5 [6.39]	169.5 [6.67]	178.2 [7.01]	189.5 [7.46]	203 [7.99]
<b>B</b>	<b>mm [in]</b>	9 [0.354]	11.3 [0.444]	14 [0.551]	17.4 [0.68]	21.8 [0.85]	27.8 [1.09]	34.8 [1.37]	43.5 [1.71]	54.8 [2.15]	68.38 [2.69]
<b>Pesi Weight</b>	<b>kg [lb]</b>	6.8 [14.96]	7 [15.42]	7.1 [15.62]	7.4 [16.28]	7.7 [16.94]	8 [17.6]	8.4 [18.48]	8.9 [19.58]	9.6 [21.12]	9.9 [21.78]

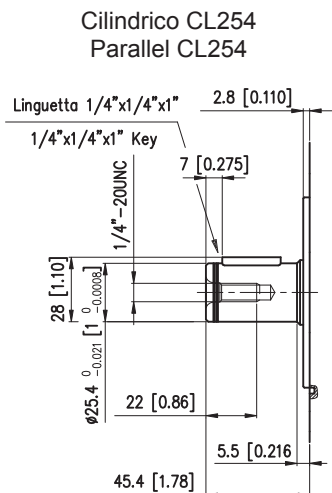

Coppia Massima 292 Nm  
Max Torque Continuous 292 Nm [215.2 lbf-ft]

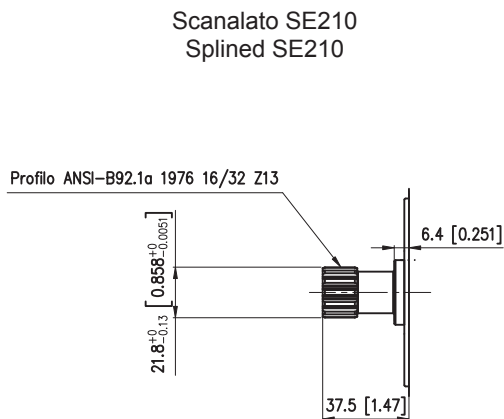

Coppia Massima 140 Nm  
Max Torque Continuous 140 Nm [103.18 lbf-ft]

Scanalato SE250  
Splined SE250

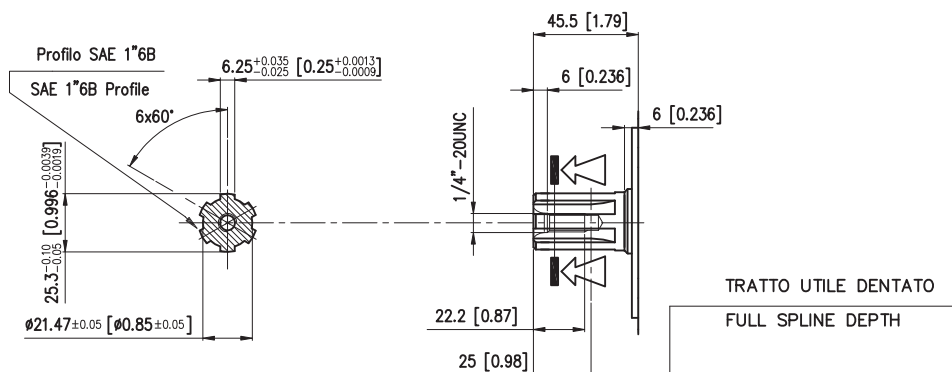

Coppia Massima 345 Nm  
Max Torque Continuous 345 Nm [254.26 lbf-ft]

**MS8**

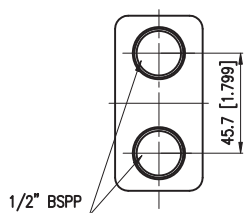

**S08**

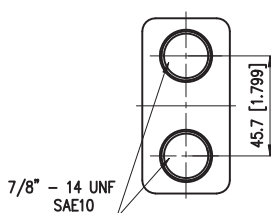

**SS8**

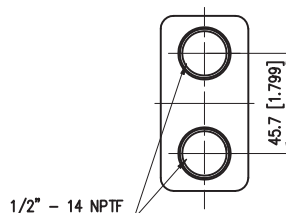

**Manifold (BFL)**

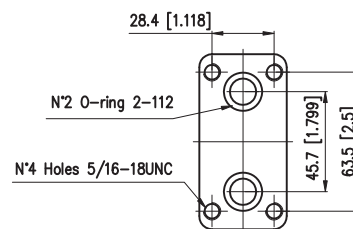

I carichi ammessi sull'albero variano in funzione di:

- Velocità (n)
- Distanza (L) dal punto di applicazione del carico alla flangia di montaggio
- Versione della flangia di montaggio

Formula utilizzabile per il calcolo del carico radiale (Pr) ai vari numeri di giri (n), e alle varie distanze (L) dalla flangia tipo "6A" ovale 6 fori. Radial load capacity (Pr) cur ve according to speed (n) and distance (L) from flange, valid for the 6-bolt flange type "6A".

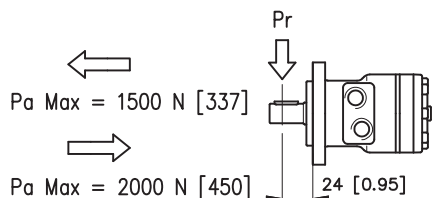

$$Pr = \frac{800}{n} \cdot \frac{242000}{97 + L} \text{ [N]}$$

Formula valida per n >= 200 rpm  
Per n < 200 rpm Pmax = 8000 N

This formula being valid for n >= 200 rpm  
For n < 200 rpm Pmax = 8000 N [1800 lbf]

The permissible radial shaft load depends on

- Speed (n)
- Distance (L) from the point of load to the mounting flange
- Mounting flange version

Formula utilizzabile per il calcolo del carico radiale (Pr) ai vari numeri di giri (n), e alle varie distanze (L) dalla flangia tipo "S4" 4 fori. Radial load capacity (Pr) cur ve according to speed (n) and distance (L) from flange, valid for the 4-bolt flange type "S4".

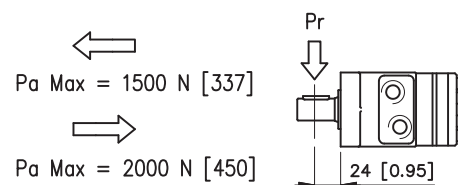

Formula valida per n >= 200 rpm  
Per n < 200 rpm Pmax = 8000 N

This formula being valid for n >= 200 rpm  
For n < 200 rpm Pmax = 8000 N [1800 lbf]

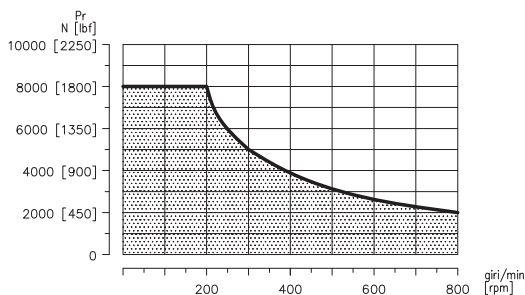

La curva mostra la relazione tra (Pr) e (n) quando:

- L = 24 mm [0.95 in] per motori flangia S4 e 6A

The curve shows the relation between (Pr) and (n)

- L = 24 mm [0.95 in] for motors with S4 and 6A flange

# BR-BS 050

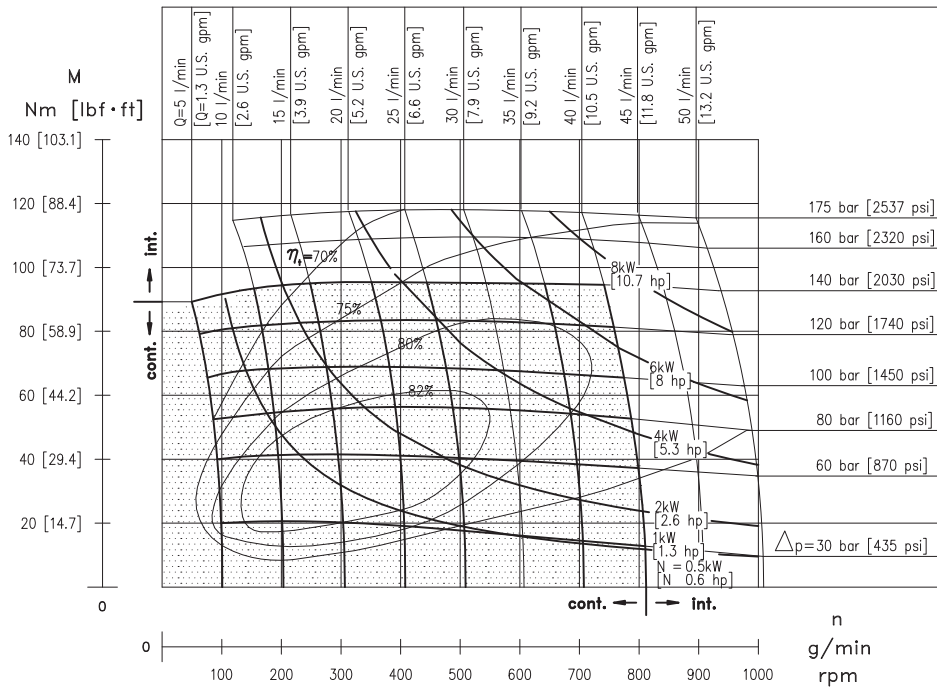

*Pressioni e portate superiori a quelle ammesse in regime continuo non devono essere applicate contemporaneamente.*

Exceeding continuous pressure values or exceeding flow values indicated, must not occur simultaneously.

# BR-BS 080

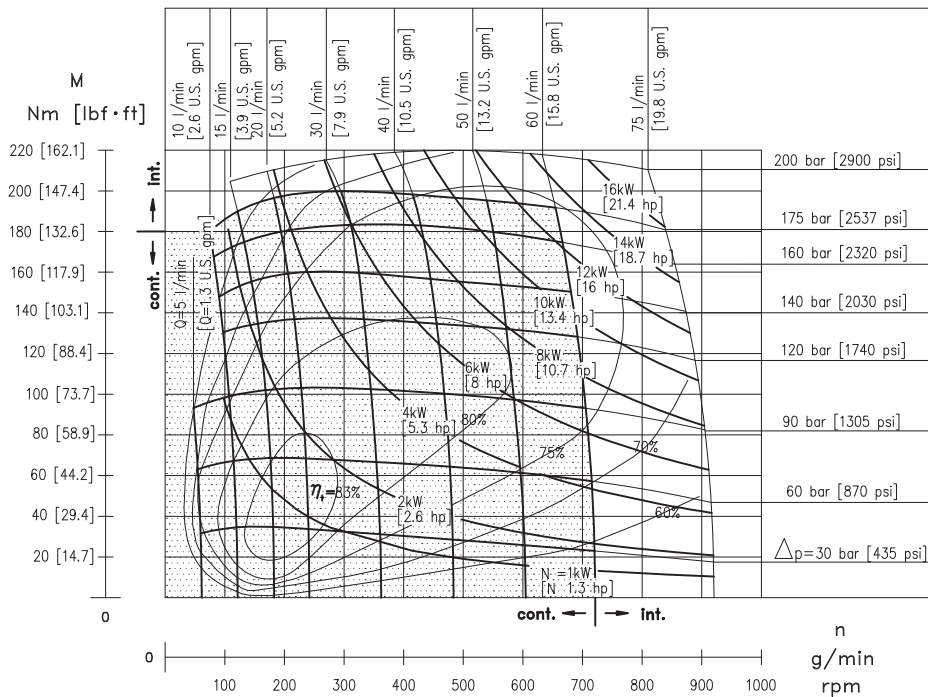

*Pressioni e portate superiori a quelle ammesse in regime continuo non devono essere applicate contemporaneamente.*

Exceeding continuous pressure values or exceeding flow values indicated, must not occur simultaneously.

# BR-BS 100

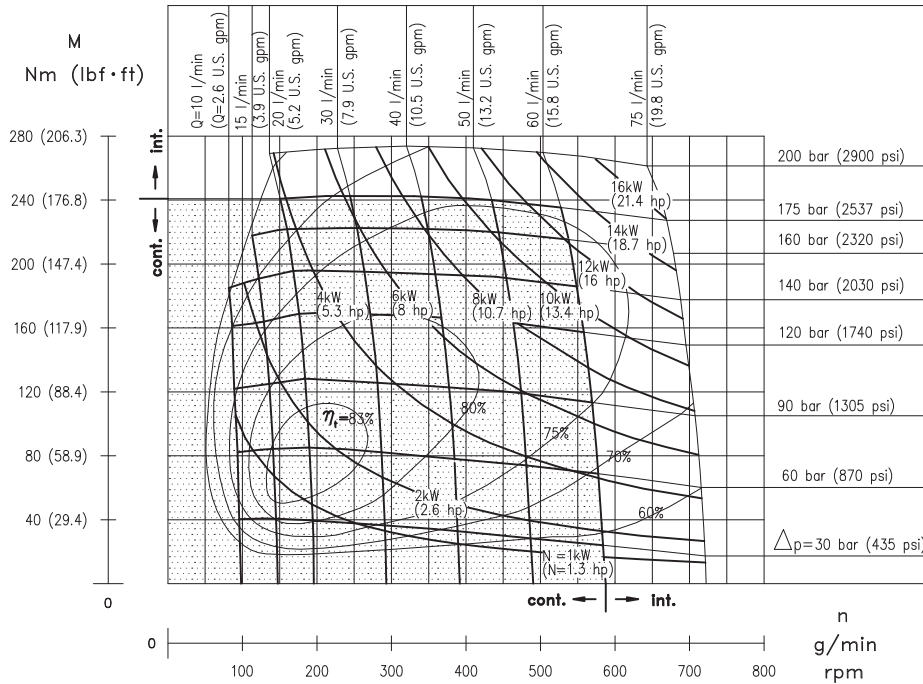

*Pressioni e portate superiori a quelle ammesse in regime continuo non devono essere applicate contemporaneamente.*

Exceeding continuous pressure values or exceeding flow values indicated, must not occur simultaneously.

# BR-BS 130

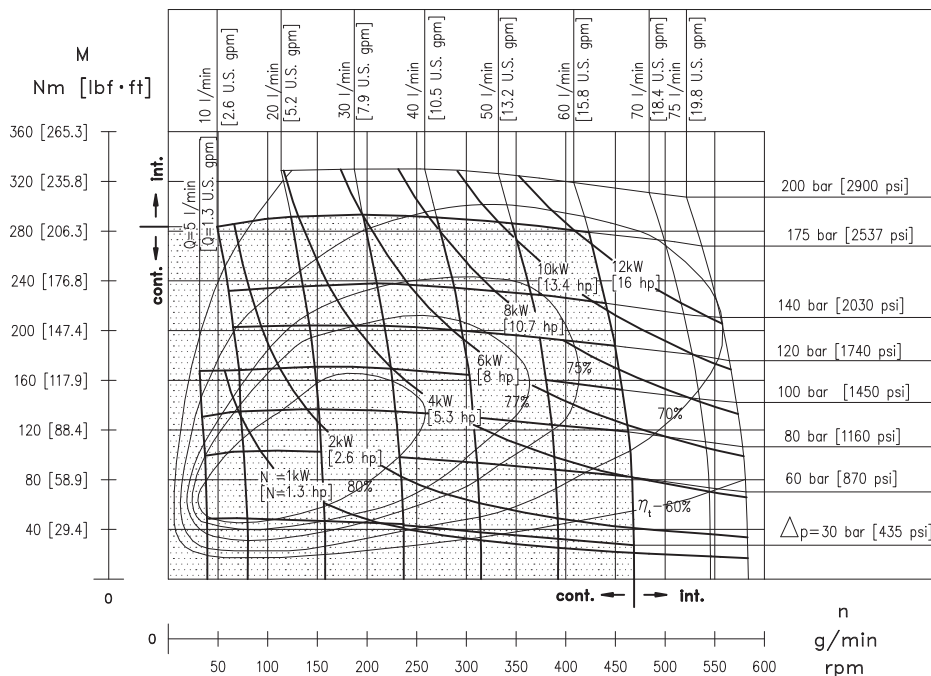

*Pressioni e portate superiori a quelle ammesse in regime continuo non devono essere applicate contemporaneamente.*

Exceeding continuous pressure values or exceeding flow values indicated, must not occur simultaneously.

# BR-BS 160

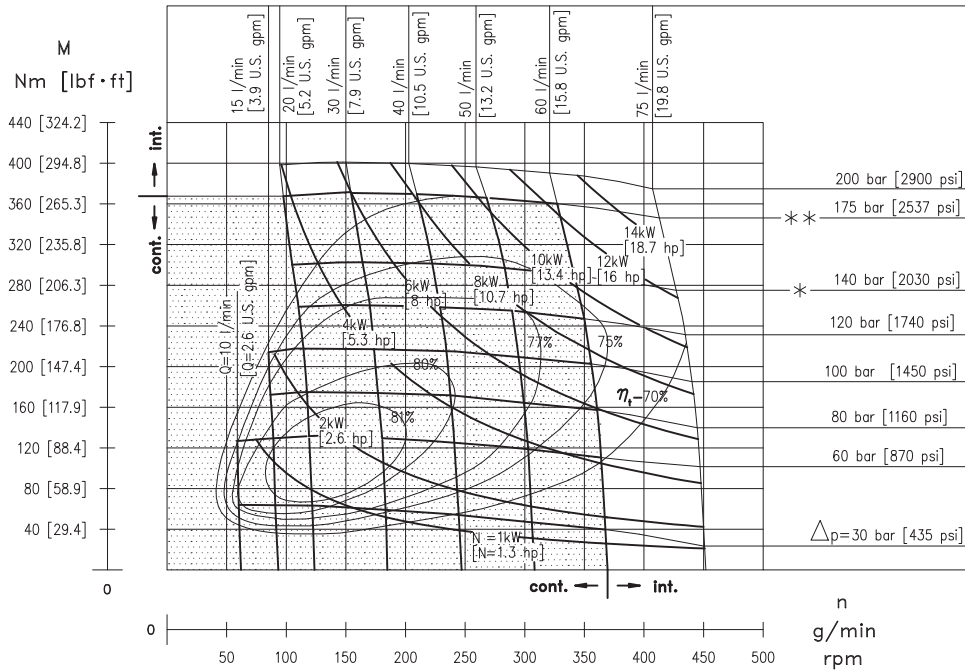

- \* Pressione massima continua per versione con albero Ø25.
- \*\* Pressione massima intermittente per versione con albero Ø25.

Pressioni e portate superiori a quelle ammesse in regime continuo non devono essere applicate contemporaneamente.

- \* Constant maximum pressure for Ø25 shaft model.
- \*\* Intermittent maximum pressure for Ø25 shaft model.

Exceeding continuous pressure values or exceeding flow values indicated, must not occur simultaneously.

# BR-BS 200

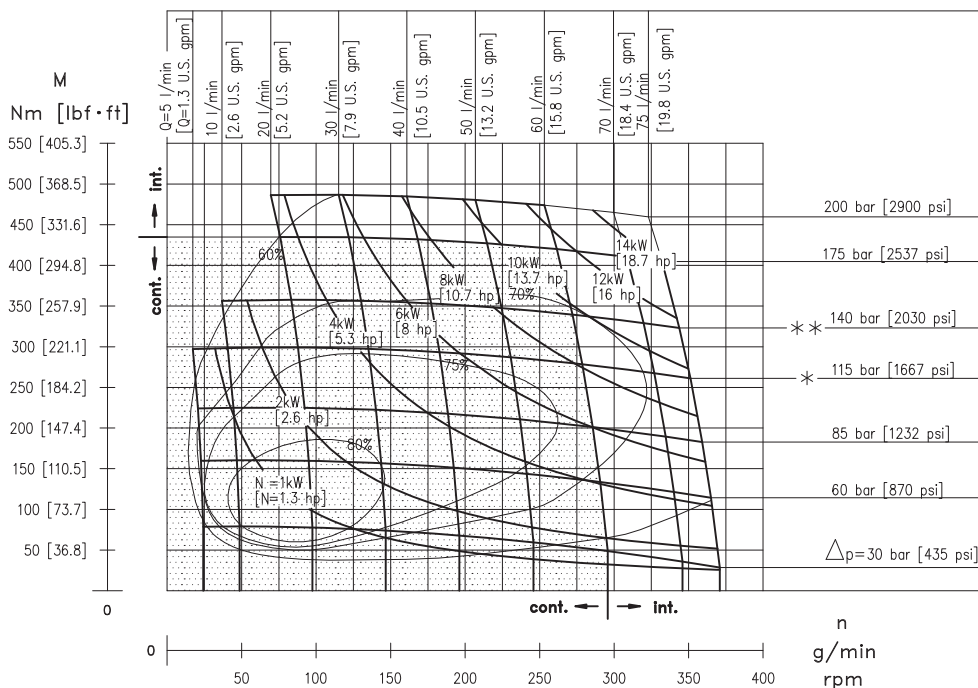

- \* Pressione massima continua per versione con albero Ø25.
- \*\* Pressione massima intermittente per versione con albero Ø25.

Pressioni e portate superiori a quelle ammesse in regime continuo non devono essere applicate contemporaneamente.

- \* Constant maximum pressure for Ø25 shaft model.
- \*\* Intermittent maximum pressure for Ø25 shaft model.

Exceeding continuous pressure values or exceeding flow values indicated, must not occur simultaneously.



# BR-BS 250

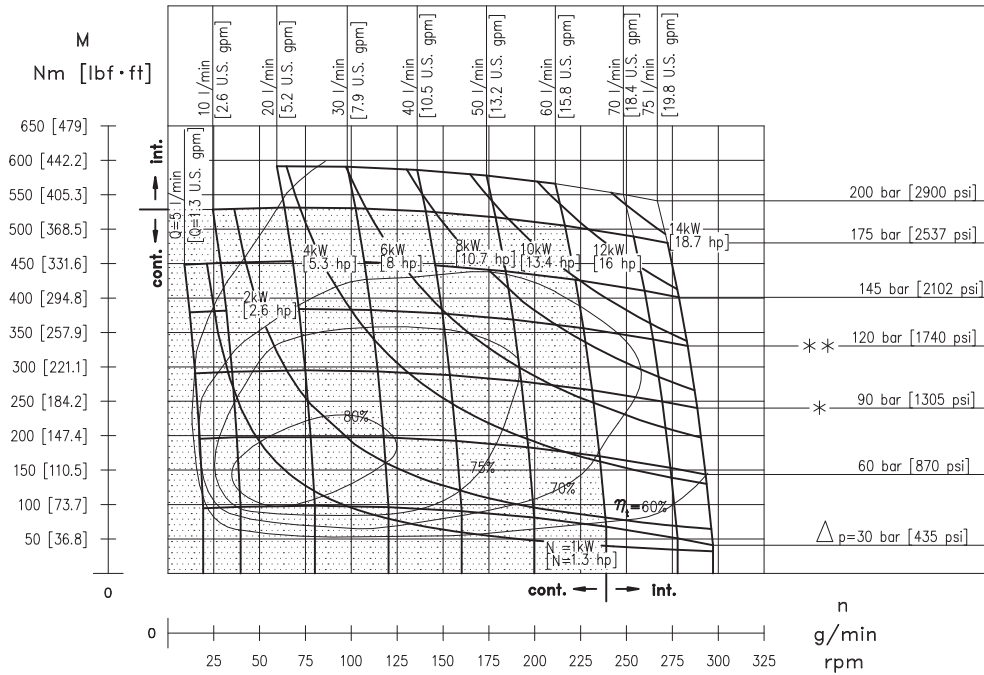

\* Pressione massima continua per versione con albero Ø25.

\*\* Pressione massima intermittente per versione con albero Ø25.

Pressioni e portate superiori a quelle ammesse in regime continuo non devono essere applicate contemporaneamente.

\* Constant maximum pressure for Ø25 shaft model.

\*\* Intermittent maximum pressure for Ø25 shaft model.

Exceeding continuous pressure values or exceeding flow values indicated, must not occur simultaneously.

# BR-BS 315

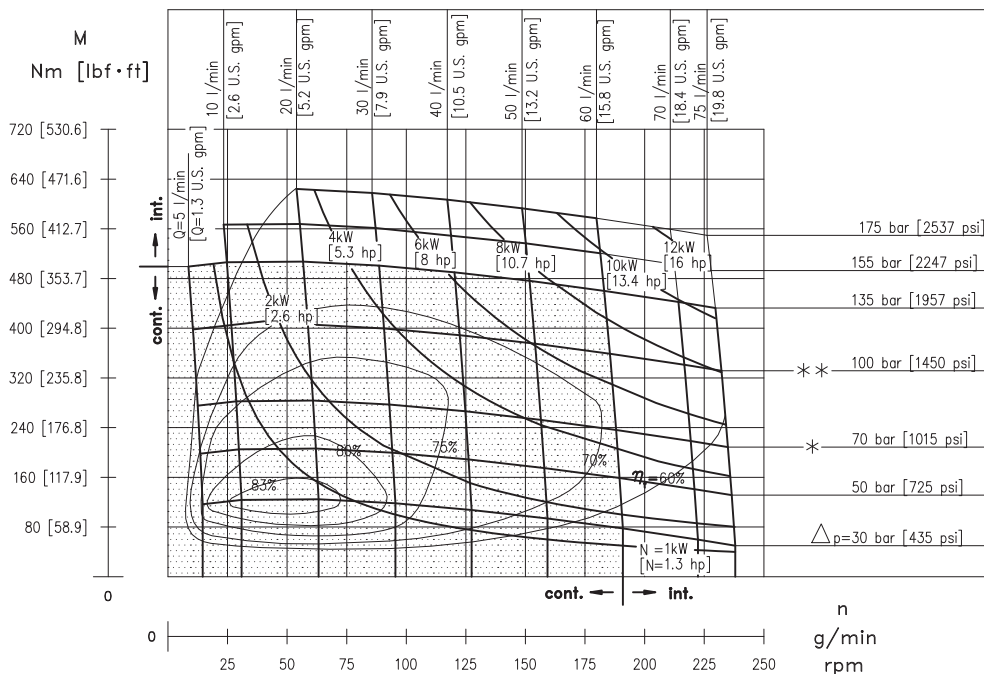

\* Pressione massima continua per versione con albero Ø25.

\*\* Pressione massima intermittente per versione con albero Ø25.

Pressioni e portate superiori a quelle ammesse in regime continuo non devono essere applicate contemporaneamente.

\* Constant maximum pressure for Ø25 shaft model.

\*\* Intermittent maximum pressure for Ø25 shaft model.

Exceeding continuous pressure values or exceeding flow values indicated, must not occur simultaneously.

# BR-BS 400

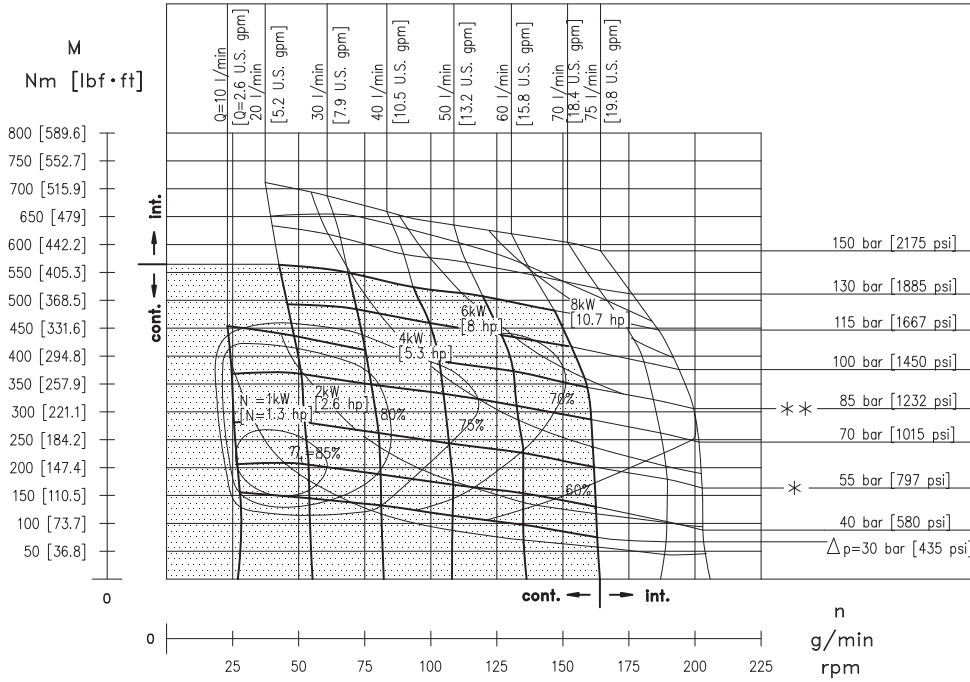

\* Pressione massima continua per versione con albero Ø25.

\*\* Pressione massima intermittente per versione con albero Ø25.

Pressioni e portate superiori a quelle ammesse in regime continuo non devono essere applicate contemporaneamente.

\* Constant maximum pressure for Ø25 shaft model.

\*\* Intermittent maximum pressure for Ø25 shaft model.

Exceeding continuous pressure values or exceeding flow values indicated, must not occur simultaneously.





**BREVINI<sup>®</sup>**

*Motion Systems*

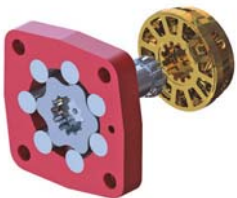
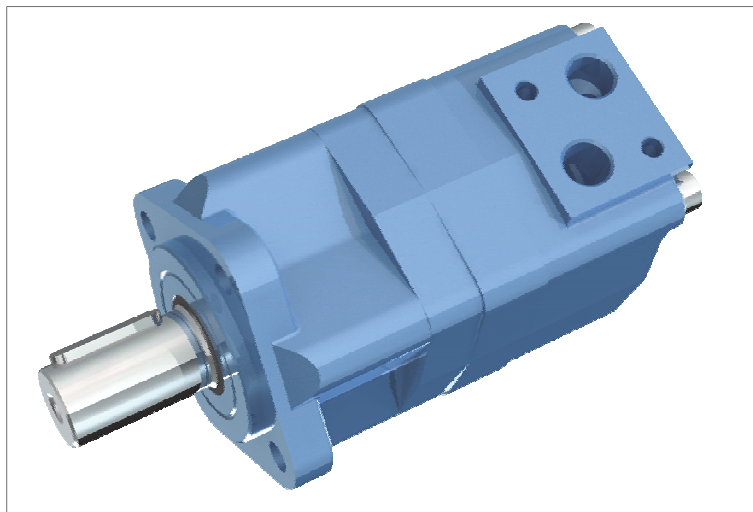

**HR**

***MOTORI ORBITALI***

**ORBITAL MOTORS**

# CARATTERISTICHE DEL MOTORE MOTOR FEATURES

**HR**

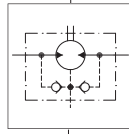

**S**

Versione Base  
Standard Version

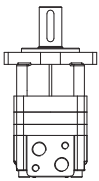

A4

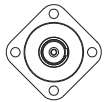

A2

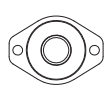

**W**

Versione Ruota  
Wheel Version

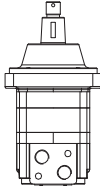

C4

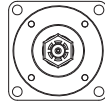

**C**

Versione Corta  
Bearingless Version

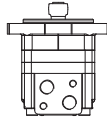

B4

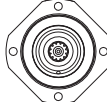

**F**

Versione Freno  
Brake Version

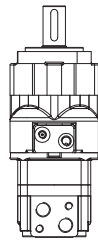

A4

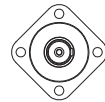

**L**

Versione Freno-Ruota  
Wheel Version with brake

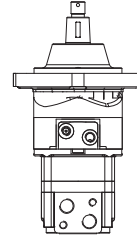

C4

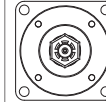

**M**

Versione corta per riduttore  
Short Version for Gear Box

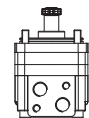

M4

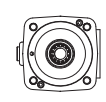

Albero supportato da due robusti cuscinetti a rulli conici che assicurano una grande tenuta ai carichi radiali (Max 40000 N).

Shaft supported by two heavy duty tapered roller bearings that ensure outstanding radial load capacity Max 40000 N [Max. 9000 lbf].

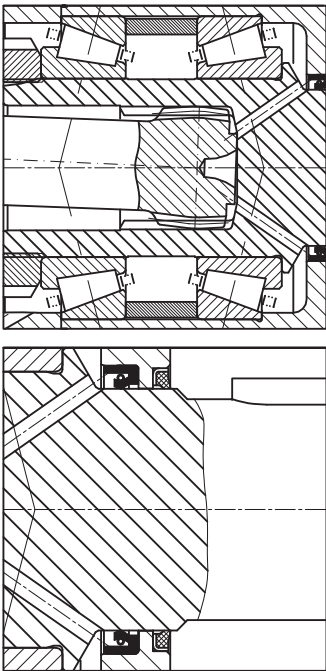

Guarnizione dell'albero in uscita ad alta pressione. Il motore è in grado di lavorare con pressioni in carcassa fino a 160 bar.

Dust Seal for high pressure of the output shaft. The motor can work with casing pressure up to 160 bar [2320 psi].

Distribuzione con valvola a disco con recupero automatico dei giochi effettuato dal fluido in pressione; viene così raggiunto un livello più basso di drenaggio ed un rendimento più elevato. Il motore è provvisto di valvole di drenaggio interne.

Disc valve distribution with automatic compensation of backlash done by fluid under pressure: lower drain figures are then guaranteed together with high efficiency. The motor is supplied with internally built-in check valves.

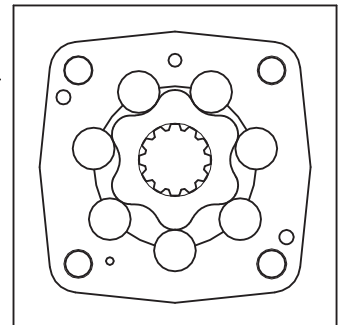
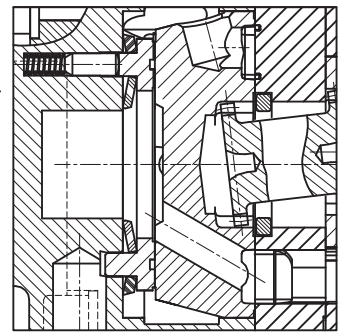
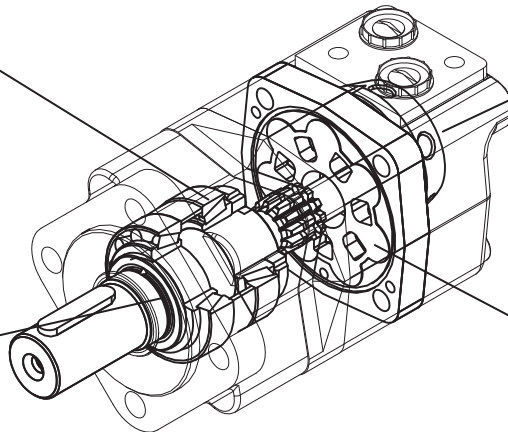

Organo motore roller che consente elevate pressioni di esercizio e lunga durata.

Heavy duty, roller type stator meant to work at high pressure and to guarantee extra long lasting.

# CARATTERISTICHE TECNICHE TECHNICAL SPECIFICATIONS

Motore Motor	Cilindrata Displacement cm <sup>3</sup> /giro [in <sup>3</sup> /rev]	Max. pressione in ingresso Max. input pressure bar [psi]		Pressione diff. max. Max. differential pressure bar [psi]		Coppia max.* Max. torque*		Portata max. Max. flow		Velocità max. Max. speed		Potenza max. Max. power	
		Cont	Int <sup>1)</sup>	Cont	Int <sup>1)</sup>	Cont	Int <sup>1)</sup>	Cont	Int <sup>1)</sup>	Cont	Int <sup>1)</sup>	Cont	Int <sup>1)</sup>
HR 080	80.4 [4.9]	Cont Int <sup>1)</sup> Peak <sup>2)</sup>	210 [3045] 310 [4495] 310 [4495]	Cont Int <sup>1)</sup> Peak <sup>2)</sup>	205 [2972] 310 [4495] 310 [4495]	Cont Int <sup>1)</sup>	235 [173] 345 [254]	Cont Int <sup>1)</sup>	75 [19.8] 80 [21.1]	Cont Int <sup>1)</sup>	932 995	Cont Int <sup>1)</sup>	23 [30.8] 36 [48.2]
HR 100	100 [6.1]	Cont Int <sup>1)</sup> Peak <sup>2)</sup>	210 [3045] 310 [4495] 310 [4495]	Cont Int <sup>1)</sup> Peak <sup>2)</sup>	205 [2972] 310 [4495] 310 [4495]	Cont Int <sup>1)</sup>	295 [217] 445 [328]	Cont Int <sup>1)</sup>	75 [19.8] 95 [25]	Cont Int <sup>1)</sup>	750 950	Cont Int <sup>1)</sup>	23.1 [30.9] 44.2 [59.2]
HR 130	125.7 [7.66]	Cont Int <sup>1)</sup> Peak <sup>2)</sup>	210 [3045] 310 [4495] 310 [4495]	Cont Int <sup>1)</sup> Peak <sup>2)</sup>	205 [2972] 310 [4495] 310 [4495]	Cont Int <sup>1)</sup>	375 [276] 545 [401]	Cont Int <sup>1)</sup>	75 [19.8] 95 [25]	Cont Int <sup>1)</sup>	596 755	Cont Int <sup>1)</sup>	23.4 [31.3] 43.1 [57.7]
HR 160	160 [9.76]	Cont Int <sup>1)</sup> Peak <sup>2)</sup>	210 [3045] 310 [4495] 310 [4495]	Cont Int <sup>1)</sup> Peak <sup>2)</sup>	205 [2972] 260 [3770] 310 [4495]	Cont Int <sup>1)</sup>	465 [342] 570 [420]	Cont Int <sup>1)</sup>	75 [19.8] 95 [25]	Cont Int <sup>1)</sup>	468 593	Cont Int <sup>1)</sup>	18.2 [24.3] 22.5 [30.1]
HR 200	200 [12.2]	Cont Int <sup>1)</sup> Peak <sup>2)</sup>	210 [3045] 310 [4495] 310 [4495]	Cont Int <sup>1)</sup> Peak <sup>2)</sup>	205 [2972] 260 [3770] 310 [4495]	Cont Int <sup>1)</sup>	580 [427] 670 [494]	Cont Int <sup>1)</sup>	75 [19.8] 95 [25]	Cont Int <sup>1)</sup>	375 475	Cont Int <sup>1)</sup>	15.2 [20.3] 22.5 [30.1]
HR 250	250 [15.25]	Cont Int <sup>1)</sup> Peak <sup>2)</sup>	210 [3045] 310 [4495] 310 [4495]	Cont Int <sup>1)</sup> Peak <sup>2)</sup>	205 [2972] 260 [3770] 310 [4495]	Cont Int <sup>1)</sup>	710 [523] 820 [604]	Cont Int <sup>1)</sup>	75 [19.8] 95 [25]	Cont Int <sup>1)</sup>	300 380	Cont Int <sup>1)</sup>	14.2 [19] 19.5 [26.1]
HR 315	314.5 [19.18]	Cont Int <sup>1)</sup> Peak <sup>2)</sup>	210 [3045] 310 [4495] 310 [4495]	Cont Int <sup>1)</sup> Peak <sup>2)</sup>	205 [2972] 240 [3480] 310 [4495]	Cont Int <sup>1)</sup>	885 [652] 960 [707]	Cont Int <sup>1)</sup>	75 [19.8] 95 [25]	Cont Int <sup>1)</sup>	238 302	Cont Int <sup>1)</sup>	11 [14.7] 19.5 [26.1]
HR 400	393 [23.97]	Cont Int <sup>1)</sup> Peak <sup>2)</sup>	210 [3045] 310 [4495] 310 [4495]	Cont Int <sup>1)</sup> Peak <sup>2)</sup>	155 [2247] 190 [2755] 225 [3250]	Cont Int <sup>1)</sup>	860 [633] 980 [722]	Cont Int <sup>1)</sup>	75 [19.8] 95 [25]	Cont Int <sup>1)</sup>	190 241	Cont Int <sup>1)</sup>	11 [14.7] 13 [17.4]

		HR 080	HR 100	HR 130	HR 160	HR 200	HR 250	HR 315	HR 400
Pressione max avviamento a vuoto Max starting pressure with no load	bar [psi]	11 [159]	10 [145]	10 [145]	8 [116]	8 [116]	8 [116]	8 [116]	8 [116]
Coppia min. di spunto (A press. diff. max) Min. starting torque (At. Max Δp)	Nm [lbf·ft]	Cont. 180 [133] Int. 270 [199]	Cont. 230 [169] Int. 340 [250]	Cont. 300 [221] Int. 420 [309]	Cont. 370 [272] Int. 440 [324]	Cont. 465 [343] Int. 522 [385]	Cont. 568 [419] Int. 640 [472]	Cont. 700 [516] Int. 760 [560]	Cont. 680 [501] Int. 775 [571]

<sup>1)</sup> Le condizioni intermittenti non devono durare più del 10% di ogni minuto.  
Intermittent duty must not exceed 10% each minute.

<sup>2)</sup> Le condizioni di picco non devono durare più del 1% di ogni minuto.  
Peak duty must not exceed 1% each minute.

\* Per i motori con gli alberi riportati nella tabella sottostante la coppia massima ammissibile è:

\* For motors with the shafts in the table below the Max. admissible torque is reduced as follows:

* Coppia max. ammissibile per tipo d'albero * Max. admissible torque for shaft type	Nm [lbf·ft]	ALBERO CILINDRICO CL254 CL254 CYLINDRICAL SHAFT	ALBERO SCANALATO SE250 SE250 SPLINED SHAFT
		Cont	300 [221]
Int <sup>1)</sup>	410 [302]	450 [332]	

<sup>1)</sup> Le condizioni intermittenti non devono durare più del 10% di ogni minuto.  
Intermittent duty must not exceed 10% each minute.

## MASSIMA PRESSIONE AMMESSA SULLA GUARNIZIONE ALBERO MAX PERMISSIBLE SHAFT SEAL PRESSURE

Pressione massima di scarico senza drenaggio o massima pressione nella linea di drenaggio.  
Per condizioni di pressione e velocità non contemplate dal presente grafico si consiglia di contattare Dana Brevini.

Max. return pressure without drain line or max. pressure in the drain line.  
For pressure and speeds not showed in the curve below, please contact Dana Brevini.

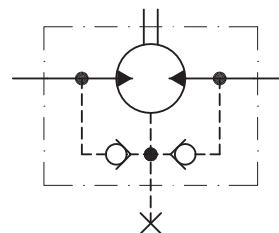
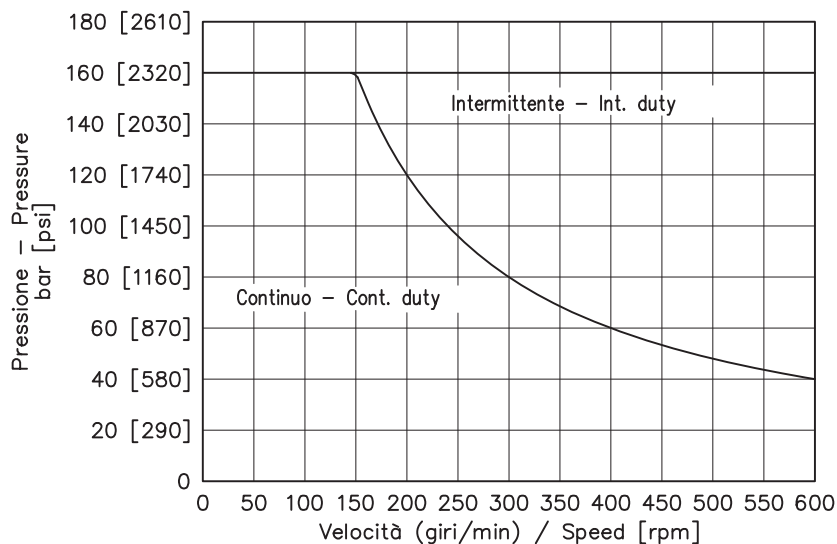

## PERDITE DI CARICO PER ATTRAVERSAMENTO PRESSURE LOSS

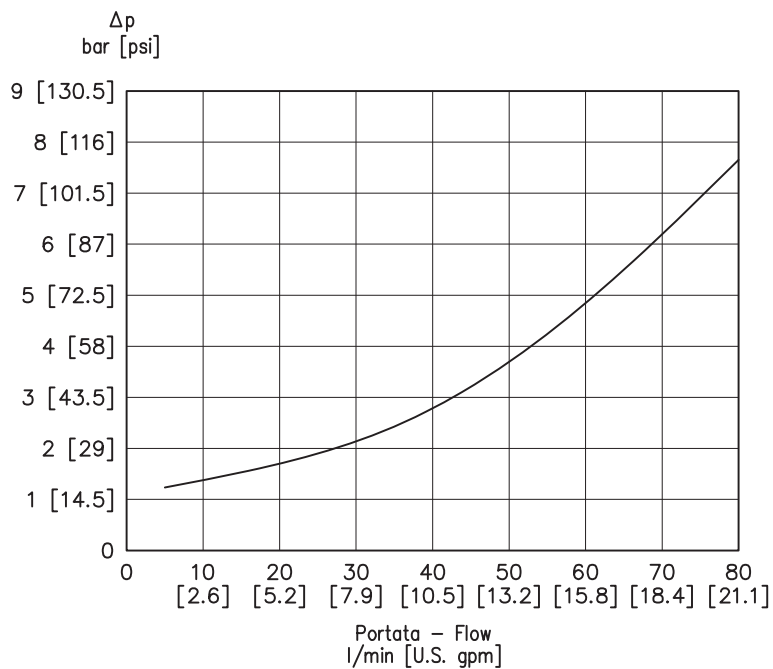

Il diagramma è stato ottenuto con prove eseguite su un numero significativo di motori, utilizzando un olio avente una viscosità cinematica di 37 cSt alla temperatura di 45 C°.

Diagram according to tests done with a relevant number of motors and using hydraulic oil with cinematic viscosity of 37 cSt at 45 C° temperature.

# CODICI DI ORDINAZIONE ORDERING CODES

Le seguenti lettere o numeri del codice, sono state sviluppate per identificare tutte le configurazioni possibili dei motori HR. Usare il seguente modulo per identificare le caratteristiche desiderate. **Tutte le lettere o numeri del codice devono comparire in fase d'ordine.** Si consiglia di leggere attentamente il catalogo prima di iniziare la compilazione del codice di ordinazione.

The following alphanumeric digits system has been developed to identify all of the configuration options for the HR motors. Use the model code below to specify the desired features. **All alphanumeric digits system of the code must be present when ordering.** We recommend to carefully read the catalogue before filling the ordering code.

## CODICE PRODOTTO / MODEL CODE

1	2	3	4	5	6	7	8	9	10	11	12	13

### 1 - SERIE / SERIES

HR	Motore orbitale Orbital motor
----	----------------------------------

### 2 - CILINDRATA / DISPLACEMENT

080	80 cm <sup>3</sup> /giro [4.88 in <sup>3</sup> /rev]
100	100 cm <sup>3</sup> /giro [6.1 in <sup>3</sup> /rev]
130	130 cm <sup>3</sup> /giro [7.93 in <sup>3</sup> /rev]
160	160 cm <sup>3</sup> /giro [9.76 in <sup>3</sup> /rev]
200	200 cm <sup>3</sup> /giro [12.2 in <sup>3</sup> /rev]
250	250 cm <sup>3</sup> /giro [15.25 in <sup>3</sup> /rev]
315	315 cm <sup>3</sup> /giro [19.21 in <sup>3</sup> /rev]
400	400 cm <sup>3</sup> /giro [24.4 in <sup>3</sup> /rev]

### 3 - VERSIONE / VERSION

S	Versione Base Standard Version	STANDARD
W	Versione Ruota Wheel Version	
C	Versione Corta Bearingless Version	
F	Versione Freno Brake Version	
L	Versione Freno-Ruota Wheel Version with brake	
M	Versione corta per riduttore Short Bearingless Version for Gear Box	

### 4 - FLANGIA / MOUNT FLANGE

		VERSIONE / VERSION					
		S	W	C	M	F	L
M4	Flangia corta per riduttore Short flange for Gear Box	/	/	/	●	/	/
A4	4 Fori (Ø 82.5 mm) 4 Bolt [Ø 3.2 in]	●	/	/	/	●	/
A2	SAE A 2 Fori SAE A 2 Bolt	●	/	/	/	○	/
B4	ISO 4 Fori (Ø 100 mm) ISO 4 Bolt [Ø 3.9 in]	/	/	●	/	/	/
CM	ISO 4 Fori (Ø 125 mm) ISO 4 Bolt [Ø 4.9 in]	/	●	/	/	/	●

● Disponibile - Available

/ Non Disponibile - Not Available

○ A Richiesta - Upon Request

1	2	3	4	5	6	7	8	9	10	11	12	13
---	---	---	---	---	---	---	---	---	----	----	----	----

### 5 - ESTREMITÀ ALBERO / SHAFT END

		VERSIONE / VERSION					
		S	W	C	M	F	L
DB001	Semigiunto Z=12 12/24 DP Dog Bone T=12 12/24 DP	/	/	•	•	/	/
CL254	Albero Cilindrico Ø25.4 mm 1 in Parallel keyed	•	/	/	/	/	/
C3175	Albero Cilindrico Ø31.75 mm 1.23 in Parallel keyed	•	/	/	/	/	/
CL320	Albero Cilindrico Ø32 mm 1.24 in Parallel keyed	•	•	/	/	•	•
CN320	Albero Conico Tapered Shaft	•	•	/	/	•	•
SE250	Albero Scanalato (profilo SAE 6B 1") Splined Shaft (SAE 6B 1" spline)	•	/	/	/	/	/
SC320	Albero Scanalato (profilo ASA 12/24) - Versione Europea Splined Shaft (ASA 12/24 spline) - Europe Version	•	•	/	/	/	/
SE320	Albero Scanalato (profilo ASA 12/24) - Versione Americana Splined Shaft (ASA 12/24 spline) - USA Version	•	/	/	/	/	/
SE350	Albero Scanalato (P.t.o. DIN 9611 Form1) Splined Shaft (P.t.o. DIN 9611 Form1)	•	/	/	/	/	/

• Disponibile - Available / Non Disponibile - Not Available

### 6 - ATTACCO / MAIN PORT

			VERSIONE / VERSION					
			S	W	C	M	F	L
M09	Attacchi 1/2 G BSPP (32x22) 1/2 G BSPP (32x22) Main Ports	STANDARD	•	•	•	•	•	•
S09	Attacchi 7/8" - 14 UNF (32x22) 7/8" - 14 UNF (32x22) Main Ports		•	•	•	/	•	•
L09	Attacchi Lateralali 1" 1/16 - 12 UN 1" 1/16 - 12 UN (Main Ports Positioned 180° apart)		•	•	•	/	•	•
F09	Attacchi Frontali 1" 1/16 - 12 UN 1" 1/16 - 12 UN (End Main Ports)		•	•	•	/	•	•
R09	Attacchi Frontali 7/8" - 14 UNF 7/8" - 14 UNF (End Main Ports)	A Richiesta Upon Request	•	•	•	•	•	•

• Disponibile - Available / Non Disponibile - Not Available

### 7 - TENUTA / SEAL

N	NBR	STANDARD
V	FKM	

### 8 - VALVOLA / VALVE

		ATTACCO / MAIN PORT				
		M09	S09	L09	F09	R09
XXXX	Non Richieste Not Required	•	•	•	•	•
M091	Valvola di massima pressione VAF 09 - D Pressure relief valve VAF 09 - D	•	/	/	/	/
M092	Valvola Antiurto e Anticavitazione VAAF 09 / 40 Anticavitation and Anti-Shock Valve VAAF 09 / 40	•	/	/	/	/
M093	Valvola bilanciata di blocco e controllo discesa VCD1 09 - S/AF Overcentre Valve with VCD1 09 - S/AF	•	/	/	/	/
M094	Valvola di controllo bilanciata a doppio effetto VCR1 09 - D/AF Double-acting overcentre valve with shuttle valve VCR1 09 - D/AF	•	/	/	/	/
M095	Valvola di controllo bilanciata a doppio effetto con valvola limitatrice di pressione VCR1 09 D/AF LDP Double-acting overcentre valve with shuttle valve VCR1 09 D/AF LDP	•	/	/	/	/
M096	Valvola Regolatrice di Portata VRP 09 Flow Control Valve VRP 09	•	/	/	/	/
M097	Valvola di massima pressione VAF 09 - D/AF Pressure relief valve VAF 09 - D/AF	•	/	/	/	/

• Disponibile - Available / Non Disponibile - Not Available

1	2	3	4	5	6	7	8	9	10	11	12	13

### 9 - CARATTERISTICA VALVOLA / VALVES FEATURE

		VALVOLA / VALVE							
		XXXX	M091	M092	M093	M094	M095	M096	M097
000	Caratteristica non necessaria Feature not necessary	•	/	/	/	/	/	/	/
032	Non Tarata (Campo Taratura 50+100 bar) Not Set [725 to 1450 psi]	/	•	/	/	/	/	/	/
018	Non Tarata (Campo Taratura 50+210 bar) Not Set [725 to 3045 psi]	/	/	•	/	/	/	/	/
029	Non Tarata (Campo Taratura 30+220 bar) Not Set [435 to 3190 psi]	/	/	/	/	•	•	/	/
019	Non Tarata (Pressione massima 315 bar) Not Set [Max pressure 4567 psi]	/	/	/	/	/	/	•	/
020	Non Tarata (Campo Taratura 100+200 bar) Not Set [1450 to 2900 psi]	/	•	/	/	/	/	/	/
022	Non Tarata (Campo Taratura 100+280 bar) Not Set [1450 to 4060 psi]	/	/	/	/	/	/	/	•
700	Rapporto di Pilotaggio 7:1 Pilot Ratio 7:1	/	/	/	•	/	/	/	/
300	Rapporto di Pilotaggio 3:1 Pilot Ratio 3:1	/	/	/	•	/	/	/	/

• Disponibile - Available / Non Disponibile - Not Available

### 10 - VALVOLA DI LAVAGGIO(\*) / FLUSHING VALVE(\*)

XX		ATTACCO / MAIN PORT				
		M09	S09	L09	F09	R09
XX	Non Richieste Not Required	•	•	•	•	•
06	Valvola di lavaggio VSC/F - 6 l/min VSC/F Flushing valve - [1.58 U.S. gpm]	•	•	/	/	/
09	Valvola di lavaggio VSC/F - 10.5 l/min VSC/F Flushing valve - [2.77 U.S. gpm]	•	•	/	/	/
15	Valvola di lavaggio VSC/F - 15 l/min VSC/F Flushing valve - [3.96 U.S. gpm]	•	•	/	/	/
21	Valvola di lavaggio VSC/F - 20 l/min VSC/F Flushing valve - [5.28 U.S. gpm]	•	•	/	/	/

• Disponibile - Available / Non Disponibile - Not Available

(\*) E' possibile abbinare le valvole di lavaggio solo con la valvola VAF 09 - D  
 (\*) It is possible to combine the flushing valves only with VAF 09 - D valve.

1	2	3	4	5	6	7	8	9	10	11	12	13
---	---	---	---	---	---	---	---	---	----	----	----	----

### 11 - OPZIONE / OPTION

XX	Nessuna Opzione None
03	Rotazione Invertita Reverse Rotation

### 12 - CARATTERISTICA VERSIONE / VERSION FEATURE

		VERSIONE / VERSION					
		S	W	C	M	F	L
XXX	Versione base Standard version	●	●	/	/	●	●
OKK	Doppio attacco drenaggio 1/4 G (BSPP) (lato mandata) Double drain port 1/4 G (BSPP) (at delivery side)	●	●	/	/	/	/
SKK	Doppio attacco drenaggio 7/16" - 20UNF (lato mandata) Double drain port 7/16" - 20UNF (at delivery side)	●	●	/	/	/	/
LWK	Bassi trafilemanti Low leakage	●	●	●	●	●	●
SWK	Doppio attacco drenaggio 7/16" - 20UNF (lato mandata) + Bassi trafilemanti Double drain port 7/16" - 20UNF (at delivery side) + Low leakage	●	●	● <sup>(1)</sup>	/	/	/
KWK	Doppio attacco drenaggio 1/4 G (BSPP) (lato mandata) + Bassi trafilemanti Double drain port 1/4 G (BSPP) (at delivery side) + Low leakage	●	●	● <sup>(1)</sup>	/	/	/
03K	Versione per Riduttore Brevini SDU31 + Bassi trafilemanti Brevini SDU31 gear box Version + Low leakage	/	/	/	●	/	/
04K	Versione 12 Molle / 10 Contatti (disponibile con cilindrata 100-315) 12 Springs / 10 Contacts Version (available with displacement 100-315)	/	/	/	/	●	●
05K	Versione 8 Molle (disponibile con cilindrata 250 - 315 - 400) 8 Springs Version (available with displacement 250 - 315 - 400)	/	/	/	/	●	●
06K	Versione Coppia maggiorata (disponibile con cilindrata 200-250) Increased braking torque Version (available with displacement 200-250)	/	/	/	/	●	●
08K	Bassi trafilemanti + Versione 8 Molle (disponibile con cilindrata 250 - 315 - 400) Low leakage + 8 Springs Version (available with displacement 250 - 315 - 400)	/	/	/	/	●	●
09K	Versione Coppia maggiorata (disponibile con cilindrata 200-250) + Bassi trafilemanti Increased braking torque Version (available with displacement 200-250) + Low leakage	/	/	/	/	●	●
10K	Corpo freno attacchi SAE Brake housing SAE ports	/	/	/	/	●	●

(1) Montaggio, si prega di contattare Dana Brevini per ulteriori informazioni.  
Assembly, please contact Dana Brevini for further information.

● Disponibile - Available

/ Non Disponibile - Not Available

### 13 - VERNICIATURA / PAINTING

XX	Non verniciato Not painted
01	Verniciato Nero RAL 9005 Black Painted RAL 9005
02	Verniciato Blu RAL 5015 Blue Painted RAL 5015



# DIMENSIONI E PESI DIMENSIONS AND WEIGHT

## VERSIONE BASE - "S" "S" - STANDARD VERSION

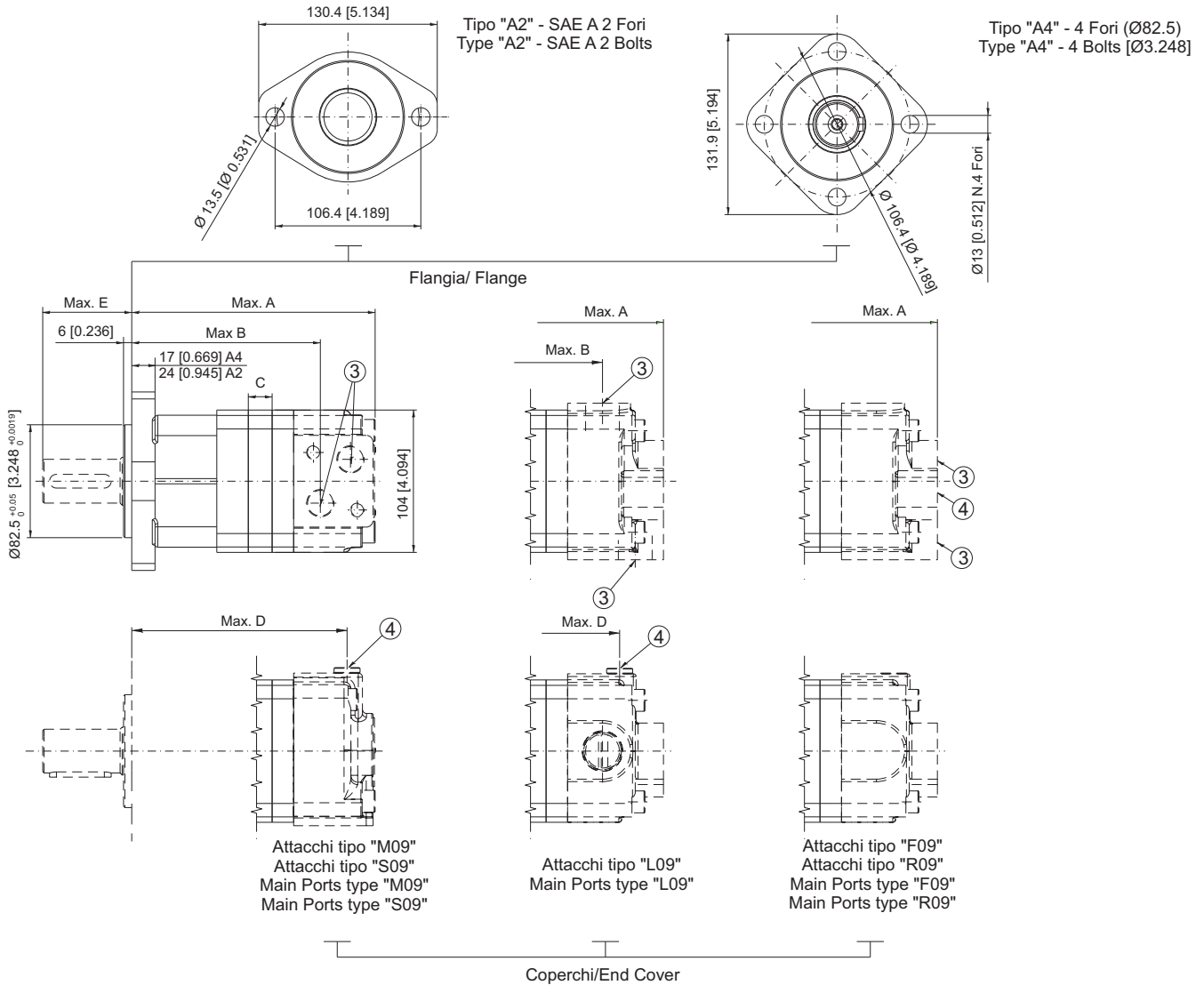

- 3) Fori Alimentazione  
Main ports
- 4) Drenaggi motore  
Drain port

\*Per le dimensioni di alberi e attacchi vedere da pag. F/16 a pag. F/18  
\*For shafts and main ports dimension see from pag. F/16 to pag. F/18

	Attacchi Tipo "M09" - Main Ports type "M09" Attacchi Tipo "S09" - Main Ports type "S09"							
Cil. (cm <sup>3</sup> /giro)	080	100	130	160	200	250	315	400
Displ. [in <sup>3</sup> /rev]	[4.8]	[6.1]	[7.9]	[9.7]	[12.2]	[15.2]	[19.2]	[24.4]
A mm	174.5	177.5	182	188	195	203.5	215	228.5
A [in]	[6.87]	[6.98]	[7.16]	[7.40]	[7.67]	[8.01]	[8.46]	[8.99]
B mm	134	137.5	142	148	155	164	175	188.5
B [in]	[5.27]	[5.41]	[5.59]	[5.82]	[6.10]	[6.45]	[6.88]	[7.42]
C mm	14	17.4	21.8	27.8	34.8	43.5	54.8	68.4
C [in]	[0.551]	[0.68]	[0.85]	[1.09]	[1.37]	[1.71]	[2.15]	[2.69]
D mm	154	157	161	167.5	174.5	183.5	194.5	208
D [in]	[6.06]	[6.18]	[6.33]	[6.59]	[6.87]	[7.22]	[7.65]	[8.18]
Pesi kg	10.5	10.7	11	11.4	11.8	12.4	13.1	14
Weight [lb]	[23.1]	[23.6]	[24.5]	[25.1]	[26]	[27.3]	[28.8]	[30.8]

	Attacchi Tipo "L09" - Main Ports type "L09" Attacchi Tipo "F09" - Main Ports type "F09" Attacchi Tipo "R09" - Main Ports type "R09"							
Cil. (cm <sup>3</sup> /giro)	080	100	130	160	200	250	315	400
Displ. [in <sup>3</sup> /rev]	[4.8]	[6.1]	[7.9]	[9.7]	[12.2]	[15.2]	[19.2]	[24.4]
A mm	185	188	192.5	198.5	205.5	214	225.5	239
A [in]	[7.28]	[7.40]	[7.57]	[7.81]	[8.09]	[8.42]	[8.87]	[9.40]
B mm	140	143.5	148	154	161	170	181	194.5
B [in]	[5.51]	[5.64]	[5.82]	[6.06]	[6.33]	[6.69]	[7.12]	[7.65]
C mm	14	17.4	21.8	27.8	34.8	43.5	54.8	68.4
C [in]	[0.551]	[0.68]	[0.85]	[1.09]	[1.37]	[1.71]	[2.15]	[2.69]
D mm	153	156	160	166.5	173.5	182.5	193.5	207
D [in]	[6.02]	[6.14]	[6.29]	[6.55]	[6.83]	[7.18]	[7.61]	[8.14]
Pesi kg	10.5	10.7	11	11.4	11.8	12.4	13.1	14
Weight [lb]	[23.1]	[23.6]	[24.5]	[25.1]	[26]	[27.3]	[28.8]	[30.8]

ALBERO SHAFT	CL320	C3175	CL254	CN320	SE250	SE320	SC320	SE350
E (mm)	65	56	51	65.9	51	55.9	65	110
E [in]	[2.55]	[2.20]	[2.00]	[2.59]	[2.00]	[2.20]	[2.55]	[4.29]

**VERSIONE RUOTA - "W"**  
**"W" - WHEEL VERSION**

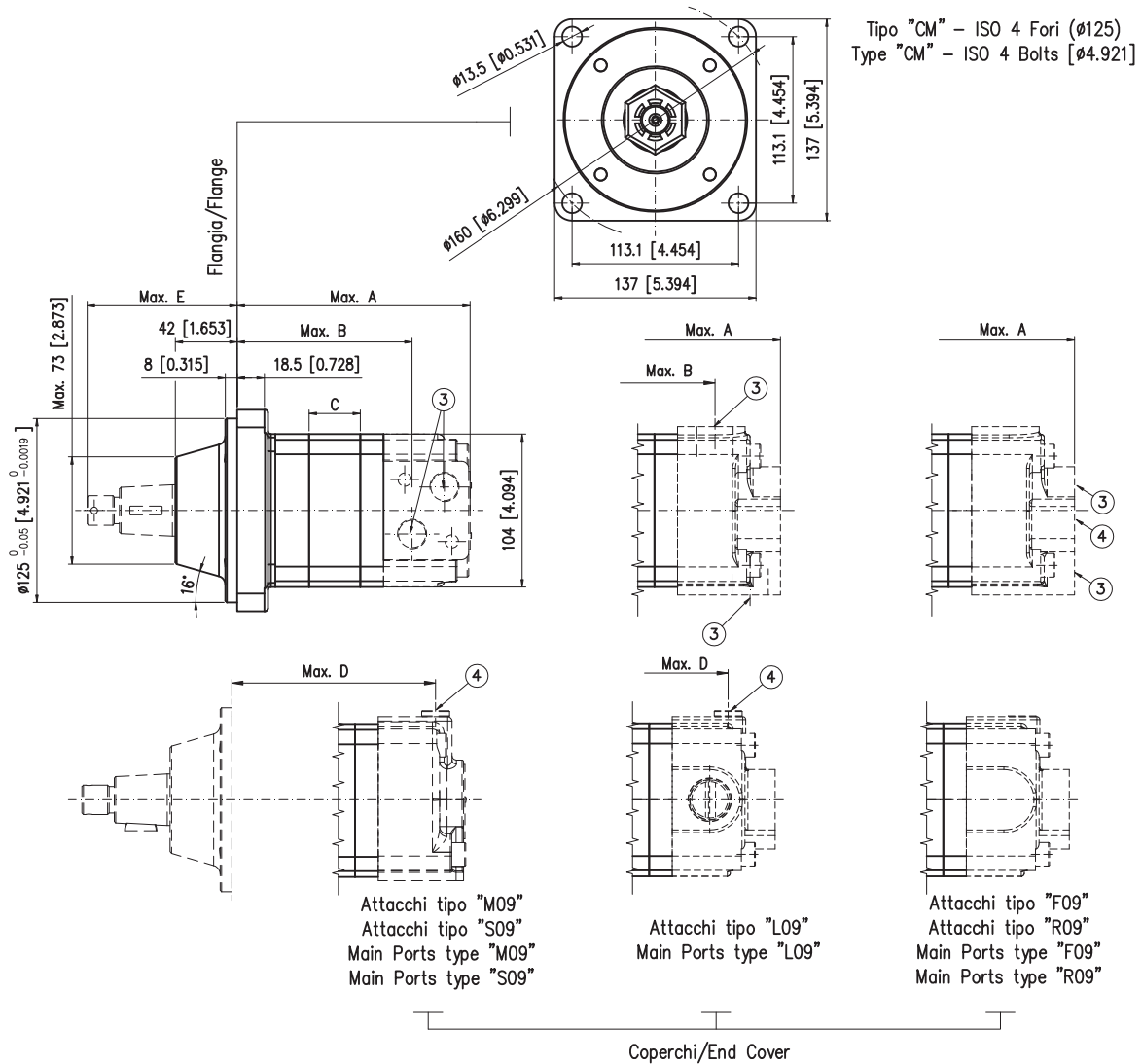

- 3) Fori Alimentazione  
 Main ports
- 4) Drenaggi motore  
 Drain port

\*Per le dimensioni di alberi e attacchi vedere da pag. F/16 a pag. F/18  
 \*For shafts and main ports dimension see from pag. F/16 to pag. F/18

Attacchi Tipo "M09" - Main Ports type "M09"								
Attacchi Tipo "S09" - Main Ports type "S09"								
Cil. (cm <sup>3</sup> /giro)	080	100	130	160	200	250	315	400
Displ. [in <sup>3</sup> /rev]	[4.8]	[6.1]	[7.9]	[9.7]	[12.2]	[15.2]	[19.2]	[24.4]
A mm	136.5	140	144.5	150.5	157.5	166	177.5	191
A [in]	[5.37]	[5.51]	[5.68]	[5.92]	[6.20]	[6.53]	[6.98]	[7.51]
B mm	97.5	101	105.3	111.3	118.3	127	138.5	152
B [in]	[3.83]	[3.97]	[4.14]	[4.38]	[4.65]	[5.00]	[5.45]	[5.98]
C mm	14	17.4	21.8	27.8	34.8	43.5	54.8	68.4
C [in]	[0.551]	[0.68]	[0.85]	[1.09]	[1.37]	[1.71]	[2.15]	[2.69]
D mm	117	120.5	124.8	130.8	137.8	146.5	158	171.5
D [in]	[4.60]	[4.74]	[4.91]	[5.14]	[5.42]	[5.76]	[6.22]	[6.75]
Pesi kg	10.9	11.1	11.5	11.8	12.2	12.9	13.6	14.4
Weight [lb]	[24]	[24.4]	[25.3]	[26]	[26.8]	[28.4]	[29.9]	[31.7]

Attacchi Tipo "L09" - Main Ports type "L09"								
Attacchi Tipo "F09" - Main Ports type "F09"								
Attacchi Tipo "R09" - Main Ports type "R09"								
Cil. (cm <sup>3</sup> /giro)	080	100	130	160	200	250	315	400
Displ. [in <sup>3</sup> /rev]	[4.8]	[6.1]	[7.9]	[9.7]	[12.2]	[15.2]	[19.2]	[24.4]
A mm	149.5	153	157.5	163.5	170.5	179	190.5	204
A [in]	[5.88]	[6.02]	[6.20]	[6.43]	[6.71]	[7.04]	[7.50]	[8.03]
B mm	103.5	107	111.3	117.3	124.3	133	144.5	158
B [in]	[4.07]	[4.21]	[4.38]	[4.61]	[4.89]	[5.23]	[5.68]	[6.22]
C (mm)	14	17.4	21.8	27.8	34.8	43.5	54.8	68.4
C [in]	[0.551]	[0.68]	[0.85]	[1.09]	[1.37]	[1.71]	[2.15]	[2.69]
D (mm)	114.5	118	122.3	128.3	135.5	144	155.5	169
D [in]	[4.50]	[4.64]	[4.81]	[5.05]	[5.33]	[5.66]	[6.12]	[6.65]
Pesi (kg)	10.9	11.1	11.5	11.8	12.2	12.9	13.6	14.4
Weight (lb)	[24]	[24.4]	[25.3]	[26]	[26.8]	[28.4]	[29.9]	[31.7]

ALBERO SHAFT	CL320	CN320	SC320
E mm	101	102	101
E [in]	[3.97]	[4.01]	[3.97]

**VERSIONE FRENO - "F"**  
**"F" - BRAKE VERSION**

Tipo "A2" - SAE A 2 Fori  
 Type "A2" - SAE A 2 Bolts

Tipo "A4" - 4 Fori (Ø82.5)  
 Type "A4" - 4 Bolts [Ø3.248]

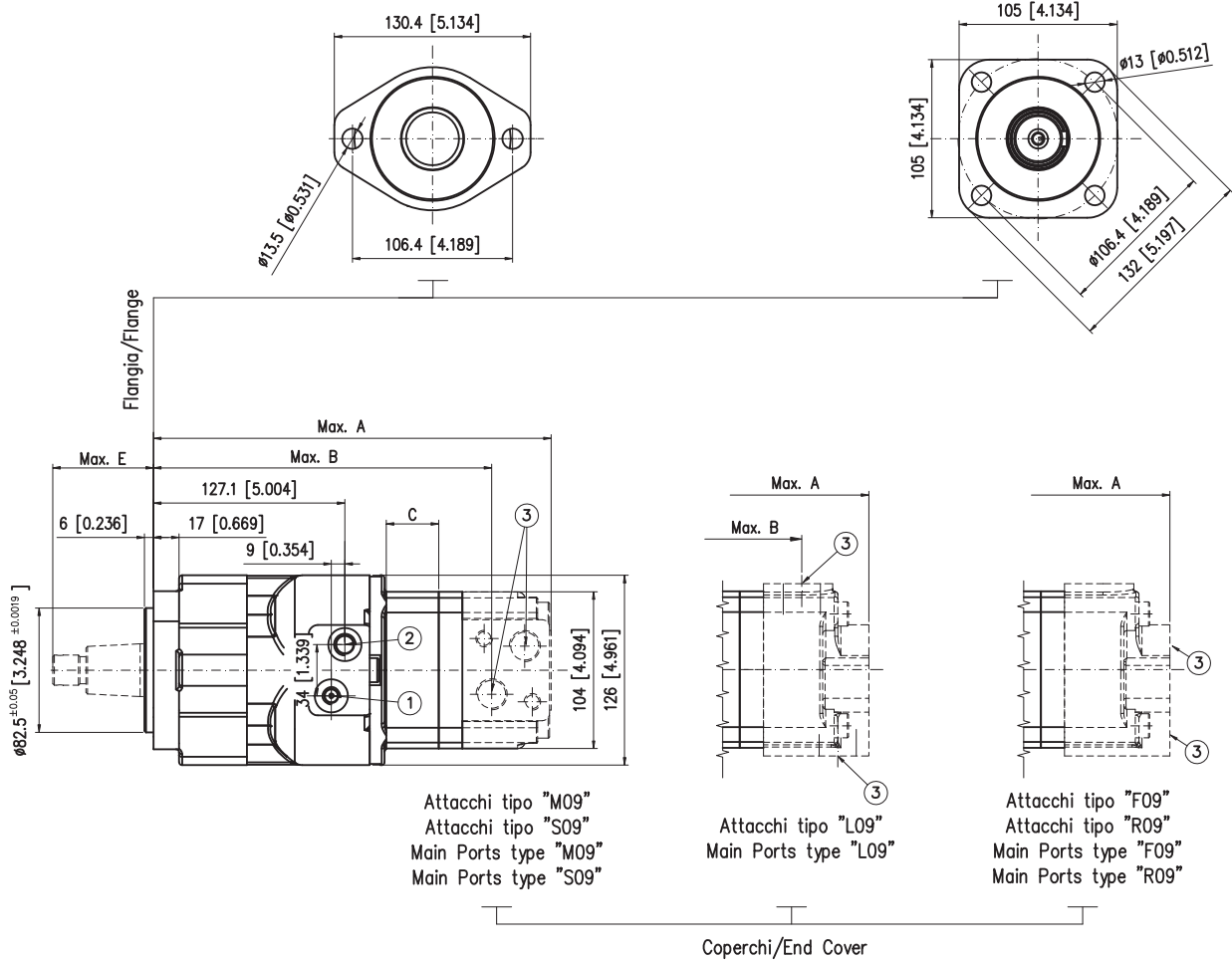

- 1) Comando apertura freno 1/8 G (BSPP) Prof.fil. 11mm (ISO)  
 1/8 G (BSPP) Brake releasing plug, thread depth [0.42 in] (ISO)  
 Comando apertura freno 7/16" - 20 UNF Prof.fil. 11mm (SAE)  
 7/16" - 20 UNF Brake releasing plug, thread depth [0.42 in] (SAE)
- 2) Drenaggio Motore 1/4 G (BSPP) Prof.fil. 11mm (ISO)  
 1/4 G (BSPP) Drain port, thread depth [0.42 in] (ISO)  
 Drenaggio Motore 7/16" - 20 UNF Prof.fil. 11mm (SAE)  
 7/16" - 20 UNF Drain port, thread depth [0.42 in] (SAE)
- 3) Fori Alimentazione  
 Main ports

\*Per le dimensioni di alberi e attacchi vedere da pag. F/16 a pag. F/18  
 \*For shafts and main ports dimension see from pag. F/16 to pag. F/18  
 \*\* Per caratteristiche freno vedere pag. F/20  
 \*\* For brake feature see pag. F/20

Attacchi Tipo "M09" - Main Ports type "M09" Attacchi Tipo "S09" - Main Ports type "S09"								
Cil. (cm <sup>3</sup> /giro) Displ. [in <sup>3</sup> /rev]	080 [4.8]	100 [6.1]	130 [7.9]	160 [9.7]	200 [12.2]	250 [15.2]	315 [19.2]	400 [24.4]
A mm	243.3	246.7	251.1	257.1	264.1	272.8	284.1	297.7
A [in]	[9.57]	[9.71]	[9.88]	[10.12]	[10.39]	[10.74]	[11.18]	[11.72]
B mm	203.8	207.2	211.6	217.6	224.6	233.3	244.6	258.2
B [in]	[8.02]	[8.15]	[8.33]	[8.56]	[8.84]	[9.18]	[9.62]	[10.16]
C mm	14	17.4	21.8	27.8	34.8	43.5	54.8	68.4
C [in]	[0.551]	[0.68]	[0.85]	[1.09]	[1.37]	[1.71]	[2.15]	[2.69]
Pesi kg	17.3	17.5	17.9	18.2	18.6	19.3	20	20.8
Weight [lb]	[38.1]	[38.5]	[39.4]	[40.1]	[40.9]	[42.5]	[44]	[45.8]

Attacchi Tipo "L09" - Main Ports type "L09" Attacchi Tipo "F09" - Main Ports type "F09" Attacchi Tipo "R09" - Main Ports type "R09"									
Cil. (cm <sup>3</sup> /giro) Displ. [in <sup>3</sup> /rev]	080 [4.8]	100 [6.1]	130 [7.9]	160 [9.7]	200 [12.2]	250 [15.2]	315 [19.2]	400 [24.4]	
A mm	254.3	257.7	262.1	268.1	275.1	283.8	295.1	308.7	
A [in]	[10.01]	[10.14]	[10.31]	[10.55]	[10.83]	[11.17]	[11.61]	[12.15]	
B mm	209.8	213.2	217.6	223.6	230.6	239.3	250.6	264.2	
B [in]	[8.25]	[8.39]	[8.56]	[8.80]	[9.07]	[9.42]	[9.86]	[10.40]	
C mm	14	17.4	21.8	27.8	34.8	43.5	54.8	68.4	
C [in]	[0.551]	[0.68]	[0.85]	[1.09]	[1.37]	[1.71]	[2.15]	[2.69]	
Pesi kg	17.3	17.5	17.9	18.2	18.6	19.3	20	20.8	
Weight [lb]	[38.1]	[38.5]	[39.4]	[40.1]	[40.9]	[42.5]	[44]	[45.8]	

ALBERO SHAFT	CL320	CN320
E mm	65	65.9
E [in]	[2.55]	[2.59]

**VERSIONE FRENO RUOTA - "L"**  
**"L" - WHEEL WITH BRAKE VERSION**

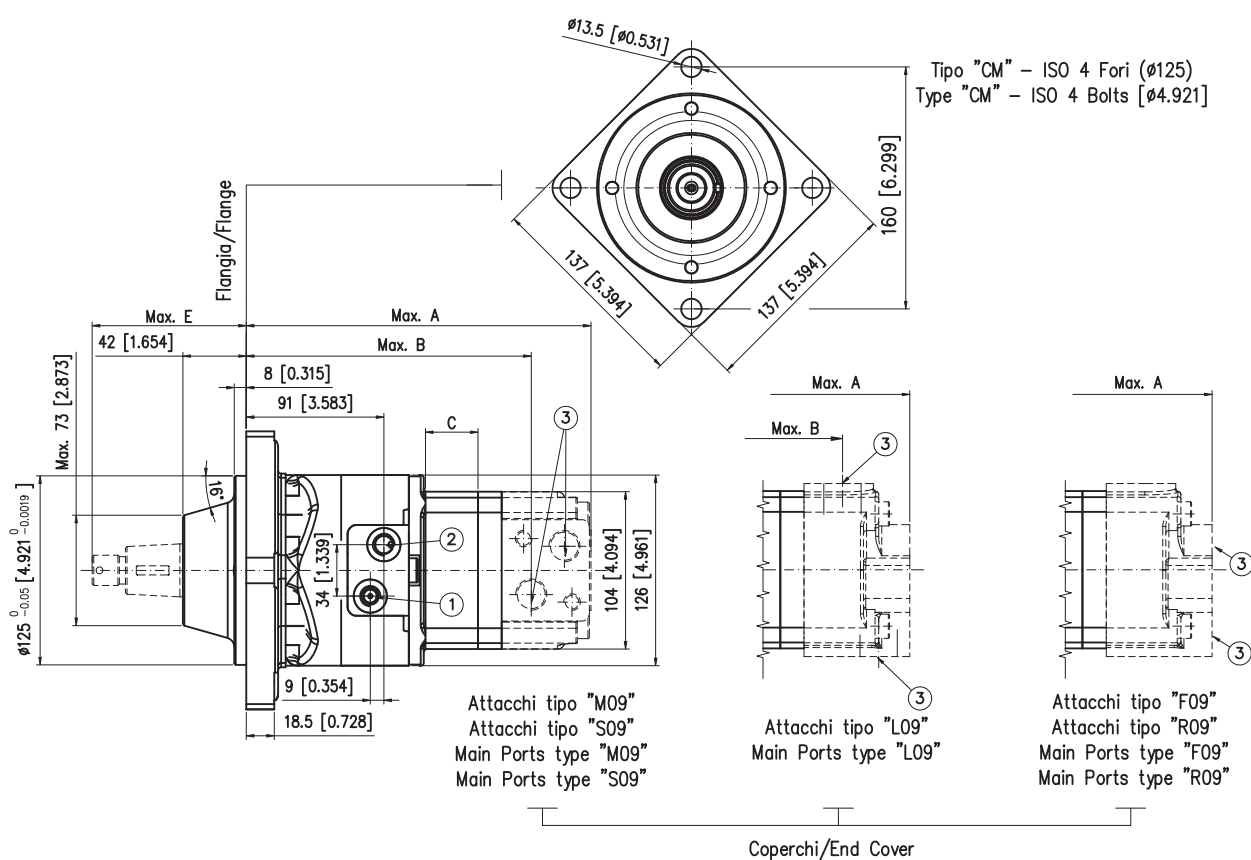

- 1) Comando apertura freno 1/8 G (BSPP) Prof.fil. 11mm (ISO)  
1/8 G (BSPP) Brake releasing plug, thread depth [0.42 in] (ISO)  
Comando apertura freno 7/16" - 20 UNF Prof.fil. 11mm (SAE)  
7/16" - 20 UNF Brake releasing plug, thread depth [0.42 in] (SAE)
- 2) Drenaggio Motore 1/4 G (BSPP) Prof.fil. 11mm (ISO)  
1/4 G (BSPP) Drain port, thread depth [0.42 in] (ISO)  
Drenaggio Motore 7/16" - 20 UNF Prof.fil. 11mm (SAE)  
7/16" - 20 UNF Drain port, thread depth [0.42 in] (SAE)
- 3) Fori Alimentazione  
Main ports

\*Per le dimensioni di alberi e attacchi vedere da pag. F/16 a pag. F/18  
 \*For shafts and main ports dimension see from pag. F/16 to pag. F/18  
 \*\* Per caratteristiche freno vedere pag. F/20  
 \*\* For brake feature see pag. F/20

Attacchi Tipo "M09" - Main Ports type "M09" Attacchi Tipo "S09" - Main Ports type "S09"									
Cil. (cm <sup>3</sup> /giro) Displ. [in <sup>3</sup> /rev]	080 [4.8]	100 [6.1]	130 [7.9]	160 [9.7]	200 [12.2]	250 [15.2]	315 [19.2]	400 [24.4]	
A mm	207.2	210.6	215	221	228	236.7	248	261.6	
A [in]	[8.15]	[8.29]	[8.46]	[8.70]	[8.97]	[9.31]	[9.76]	[10.29]	
B mm	167.7	171.1	175.5	181.5	188.5	197.2	208.5	222.1	
B [in]	[6.60]	[6.73]	[6.90]	[7.14]	[7.42]	[7.76]	[8.20]	[8.74]	
C mm	14	17.4	21.8	27.8	34.8	43.5	54.8	68.4	
C [in]	[0.551]	[0.68]	[0.85]	[1.09]	[1.37]	[1.71]	[2.15]	[2.69]	
Pesi kg Weight [lb]	17.7 [39]	17.9 [39.4]	18.3 [40.3]	18.6 [40.9]	19 [41.8]	19.7 [43.4]	20.4 [44.9]	21.2 [46.7]	

Attacchi Tipo "L09" - Main Ports type "L09" Attacchi Tipo "F09" - Main Ports type "F09" Attacchi Tipo "R09" - Main Ports type "R09"									
Cil. (cm <sup>3</sup> /giro) Displ. [in <sup>3</sup> /rev]	080 [4.8]	100 [6.1]	130 [7.9]	160 [9.7]	200 [12.2]	250 [15.2]	315 [19.2]	400 [24.4]	
A mm	218.2	221.6	226	232	239	247.7	259	272.6	
A [in]	[8.59]	[8.72]	[8.89]	[9.13]	[9.40]	[9.75]	[10.19]	[10.73]	
B mm	173.7	177.1	181.5	187.5	194.5	203.2	214.5	228.1	
B [in]	[6.83]	[6.97]	[7.14]	[7.38]	[7.65]	[8.00]	[8.44]	[8.98]	
C mm	14	17.4	21.8	27.8	34.8	43.5	54.8	68.4	
C [in]	[0.551]	[0.68]	[0.85]	[1.09]	[1.37]	[1.71]	[2.15]	[2.69]	
Pesi kg Weight [lb]	17.7 [39]	17.9 [39.4]	18.3 [40.3]	18.6 [40.9]	19 [41.8]	19.7 [43.4]	20.4 [44.9]	21.2 [46.7]	

ALBERO SHAFT	CL320	CN320
E mm	101	102
E [in]	[3.97]	[4.01]

**VERSIONE CORTA - "C"**  
**"C" - BEARINGLESS VERSION**

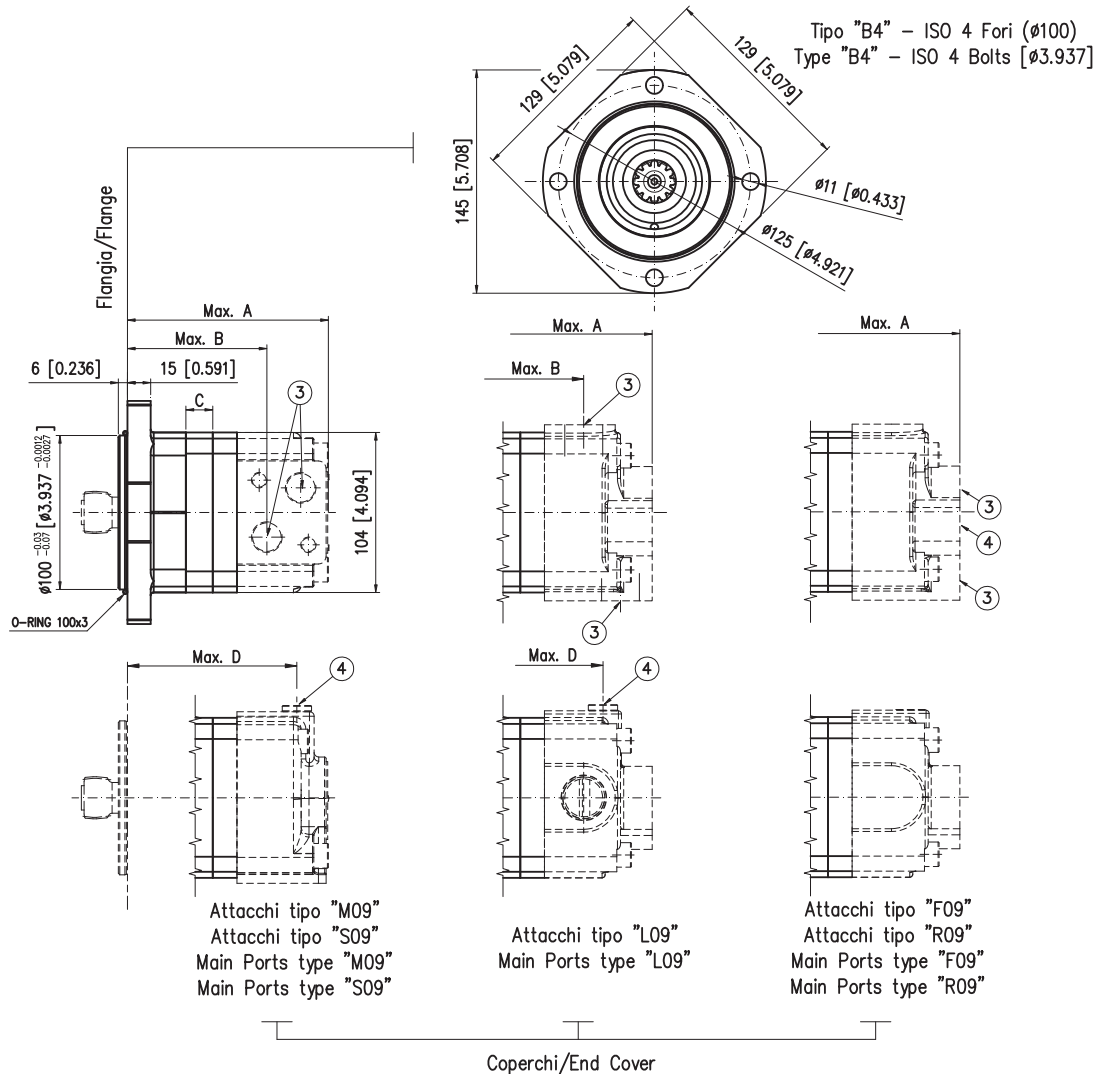

- 3) Fori Alimentazione  
Main ports
- 4) Drenaggi motore  
Drain port

\*Per le dimensioni degli attacchi vedere da pag. F/17 a pag. F/18  
 \*\* Per la sede di accoppiamento vedere pag. F/15  
 \*For main ports dimension see from pag. F/17 to pag. F/18  
 \*\* For interface drawing see pag. F/15

	Attacchi Tipo "M09" - Main Ports type "M09"						Attacchi Tipo "S09" - Main Ports type "S09"									
	080	100	130	160	200	250	315	400	080	100	130	160	200	250	315	400
Cil. (cm <sup>3</sup> /giro)	080	100	130	160	200	250	315	400	080	100	130	160	200	250	315	400
Displ. [in <sup>3</sup> /rev]	[4.8]	[6.1]	[7.9]	[9.7]	[12.2]	[15.2]	[19.2]	[24.4]	[4.8]	[6.1]	[7.9]	[9.7]	[12.2]	[15.2]	[19.2]	[24.4]
A mm	127.7	131	135.5	141.5	148.5	157.2	168.5	182	127.7	131	135.5	141.5	148.5	157.2	168.5	182
A [in]	[5.02]	[5.15]	[5.33]	[5.57]	[5.84]	[6.18]	[6.63]	[7.16]	[5.02]	[5.15]	[5.33]	[5.57]	[5.84]	[6.18]	[6.63]	[7.16]
B mm	87.2	90.6	95	101	108	116.7	128	141.6	87.2	90.6	95	101	108	116.7	128	141.6
B [in]	[3.43]	[3.56]	[3.74]	[3.97]	[4.25]	[4.59]	[5.03]	[5.57]	[3.43]	[3.56]	[3.74]	[3.97]	[4.25]	[4.59]	[5.03]	[5.57]
C mm	14	17.4	21.8	27.8	34.8	43.5	54.8	68.4	14	17.4	21.8	27.8	34.8	43.5	54.8	68.4
C [in]	[0.551]	[0.68]	[0.85]	[1.09]	[1.37]	[1.71]	[2.15]	[2.69]	[0.551]	[0.68]	[0.85]	[1.09]	[1.37]	[1.71]	[2.15]	[2.69]
D mm	106.7	110	114.5	120.5	127.5	136.2	147.5	161	106.7	110	114.5	120.5	127.5	136.2	147.5	161
D [in]	[4.20]	[4.33]	[4.50]	[4.74]	[5.01]	[5.36]	[5.80]	[6.33]	[4.20]	[4.33]	[4.50]	[4.74]	[5.01]	[5.36]	[5.80]	[6.33]
Pesi kg	8	8.2	8.6	8.9	9.3	10	10.7	11.5	8	8.2	8.6	8.9	9.3	10	10.7	11.5
Weight (lb)	[17.6]	[18]	[18.9]	[19.6]	[20.4]	[22]	[23.5]	[25.3]	[17.6]	[18]	[18.9]	[19.6]	[20.4]	[22]	[23.5]	[25.3]

	Attacchi Tipo "L09" - Main Ports type "L09"						Attacchi Tipo "F09" - Main Ports type "F09"						Attacchi Tipo "R09" - Main Ports type "R09"											
	080	100	130	160	200	250	315	400	080	100	130	160	200	250	315	400	080	100	130	160	200	250	315	400
Cil. (cm <sup>3</sup> /giro)	080	100	130	160	200	250	315	400	080	100	130	160	200	250	315	400	080	100	130	160	200	250	315	400
Displ. [in <sup>3</sup> /rev]	[4.8]	[6.1]	[7.9]	[9.7]	[12.2]	[15.2]	[19.2]	[24.4]	[4.8]	[6.1]	[7.9]	[9.7]	[12.2]	[15.2]	[19.2]	[24.4]	[4.8]	[6.1]	[7.9]	[9.7]	[12.2]	[15.2]	[19.2]	[24.4]
A mm	140.7	144	149.5	154.5	161.5	170.2	181.5	195	140.7	144	149.5	154.5	161.5	170.2	181.5	195	140.7	144	149.5	154.5	161.5	170.2	181.5	195
A [in]	[5.53]	[5.66]	[5.88]	[6.08]	[6.35]	[6.70]	[7.14]	[7.67]	[5.53]	[5.66]	[5.88]	[6.08]	[6.35]	[6.70]	[7.14]	[7.67]	[5.53]	[5.66]	[5.88]	[6.08]	[6.35]	[6.70]	[7.14]	[7.67]
B mm	93.2	96.6	101	107	114	122.7	134	147.6	93.2	96.6	101	107	114	122.7	134	147.6	93.2	96.6	101	107	114	122.7	134	147.6
B [in]	[3.66]	[3.80]	[3.97]	[4.21]	[4.48]	[4.83]	[5.27]	[5.81]	[3.66]	[3.80]	[3.97]	[4.21]	[4.48]	[4.83]	[5.27]	[5.81]	[3.66]	[3.80]	[3.97]	[4.21]	[4.48]	[4.83]	[5.27]	[5.81]
C mm	14	17.4	21.8	27.8	34.8	43.5	54.8	68.4	14	17.4	21.8	27.8	34.8	43.5	54.8	68.4	14	17.4	21.8	27.8	34.8	43.5	54.8	68.4
C [in]	[0.551]	[0.68]	[0.85]	[1.09]	[1.37]	[1.71]	[2.15]	[2.69]	[0.551]	[0.68]	[0.85]	[1.09]	[1.37]	[1.71]	[2.15]	[2.69]	[0.551]	[0.68]	[0.85]	[1.09]	[1.37]	[1.71]	[2.15]	[2.69]
D mm	104.2	107.5	112	118	125	133.7	145	158.5	104.2	107.5	112	118	125	133.7	145	158.5	104.2	107.5	112	118	125	133.7	145	158.5
D [in]	[4.10]	[4.23]	[4.40]	[4.64]	[4.92]	[5.26]	[5.70]	[6.24]	[4.10]	[4.23]	[4.40]	[4.64]	[4.92]	[5.26]	[5.70]	[6.24]	[4.10]	[4.23]	[4.40]	[4.64]	[4.92]	[5.26]	[5.70]	[6.24]
Pesi kg	8	8.2	8.6	8.9	9.3	10	10.7	11.5	8	8.2	8.6	8.9	9.3	10	10.7	11.5	8	8.2	8.6	8.9	9.3	10	10.7	11.5
Weight (lb)	[17.6]	[18]	[18.9]	[19.6]	[20.4]	[22]	[23.5]	[25.3]	[17.6]	[18]	[18.9]	[19.6]	[20.4]	[22]	[23.5]	[25.3]	[17.6]	[18]	[18.9]	[19.6]	[20.4]	[22]	[23.5]	[25.3]

**VERSIONE CORTA PER RIDUTTORE - "M"**  
**"M" - SHORT BEARINGLESS VERSION FOR GEAR BOX**

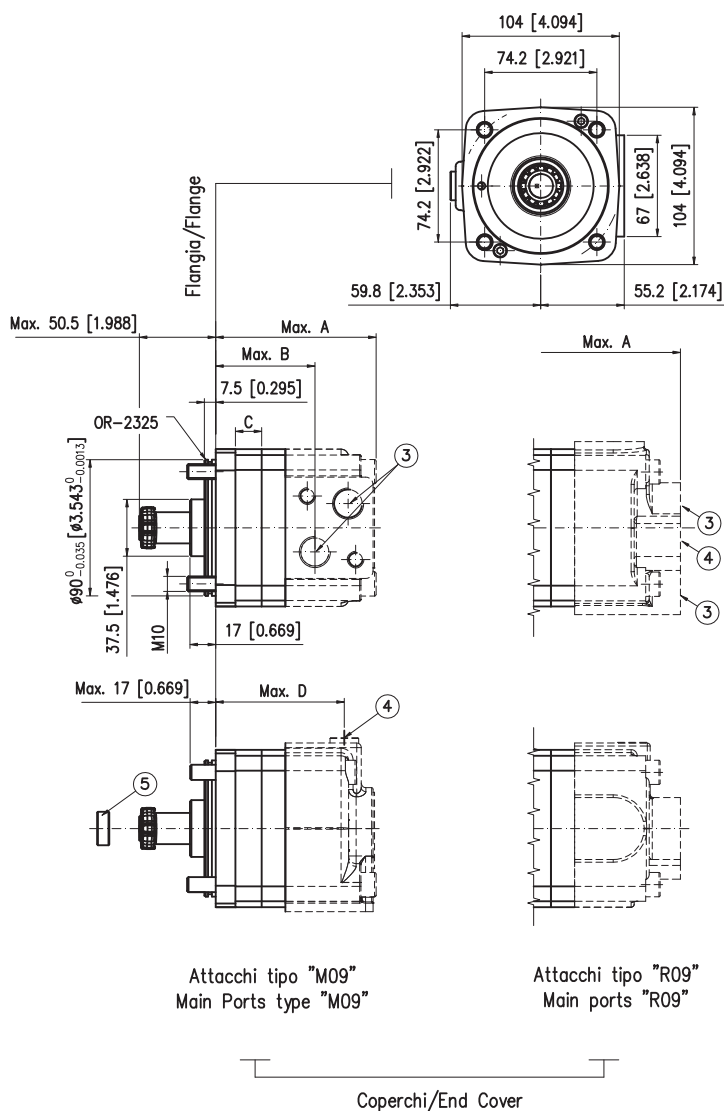

- 3) Fori di alimentazione  
Main ports
- 4) Drenaggio Motore  
Drain port
- 5) I motori sono forniti con distanziale  
The motors are supplied with spacer

\* Per la sede di accoppiamento vedere pag. F/15  
 \* For interface drawing see pag. F/15

Attacchi Tipo "M09" - Main Ports type "M09"								
Cil. (cm <sup>3</sup> /giro)	080	100	130	160	200	250	315	400
Displ. [in <sup>3</sup> /rev]	[4.8]	[6.1]	[7.9]	[9.7]	[12.2]	[15.2]	[19.2]	[24.4]
A mm	102.6	106	110.4	116.4	123.4	132.1	143.4	157
A [in]	[4.03]	[4.17]	[4.34]	[4.58]	[4.85]	[5.20]	[5.64]	[6.18]
B mm	62.2	65.6	70	76	83	91.7	103	116.6
B [in]	[2.44]	[2.58]	[2.75]	[2.99]	[3.26]	[3.61]	[4.05]	[4.59]
C mm	14	17.4	21.8	27.8	34.8	43.5	54.8	68.4
C [in]	[0.551]	[0.68]	[0.85]	[1.09]	[1.37]	[1.71]	[2.15]	[2.69]
D mm	81.6	85	89.4	95.4	102.4	111.1	122.4	136
D [in]	[3.21]	[3.34]	[3.51]	[3.75]	[4.03]	[4.37]	[4.81]	[5.35]
Pesi kg	6.5	6.7	7.1	7.5	8	8.6	9.4	10.3
Weight (lb)	[14.3]	[14.7]	[15.6]	[16.5]	[17.6]	[18.9]	[20.7]	[22.7]

Attacchi Tipo "R09" - Main Ports type "R09"								
Cil. (cm <sup>3</sup> /giro)	080	100	130	160	200	250	315	400
Displ. [in <sup>3</sup> /rev]	[4.8]	[6.1]	[7.9]	[9.7]	[12.2]	[15.2]	[19.2]	[24.4]
A mm	112.5	115.9	120.3	126.3	133.3	142	153.3	166.9
A [in]	[4.42]	[4.56]	[4.73]	[4.97]	[5.24]	[5.59]	[6.03]	[6.57]
B mm	/	/	/	/	/	/	/	/
B [in]	/	/	/	/	/	/	/	/
C mm	14	17.4	21.8	27.8	34.8	43.5	54.8	68.4
C [in]	[0.551]	[0.68]	[0.85]	[1.09]	[1.37]	[1.71]	[2.15]	[2.69]
D mm	/	/	/	/	/	/	/	/
D [in]	/	/	/	/	/	/	/	/
Pesi kg	8	8.2	8.6	8.9	9.3	10	10.7	11.5
Weight (lb)	[17.6]	[18]	[18.9]	[19.6]	[20.4]	[22]	[23.5]	[25.3]

## SEDE DI ACCOPPIAMENTO PER MOTORE HR VERSIONE "C" INTERFACE DRAWING FOR HR MOTOR "C" VERSION

<b>Profilo scanalato ANS B 92.1 + 1970 Classe 5 (corretto <math>m \cdot x = 0.8</math>) Splines ANS B 92.1 + 1970 Class 5 (corrected <math>m \cdot x = 0.8</math>)</b>	
Diametral pitch	12/24
N° denti Number of teeth	Z=12
Diametro primitivo Pitch diameter	Dp=25.4
Angolo di pressione Pressure angle	30°
Modulo Module	m=2.1166
Diametro interno Minor diameter	Di=23.0 $\begin{matrix} +0.033 \\ 0 \end{matrix}$
Diametro esterno Major diameter	De=28.0 $\begin{matrix} 0 \\ -0.1 \end{matrix}$
Misura massima tra i rullini* Max measurement between pins*	17.62 $\begin{matrix} +0.15 \\ 0 \end{matrix}$
Diametro rullini Pins diameter	4.835 $\pm 0.001$
* Dimensioni definitive dopo il trattamento * Finished dimensions (when hardened)	

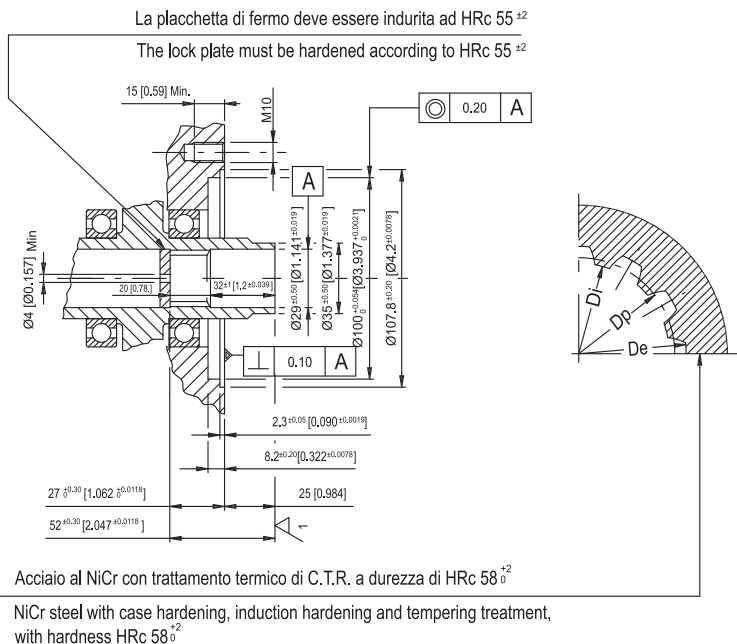

## SEDE DI ACCOPPIAMENTO PER MOTORE HR VERSIONE "M" INTERFACE DRAWING FOR HR MOTOR "M" VERSION

<b>Profilo scanalato ANS B 92.1 + 1970 Classe 5 (corretto <math>m \cdot x = 0.8</math>) Splines ANS B 92.1 + 1970 Class 5 (corrected <math>m \cdot x = 0.8</math>)</b>	
Diametral pitch	12/24
N° denti Number of teeth	Z=12
Diametro primitivo Pitch diameter	Dp=25.4
Angolo di pressione Pressure angle	30°
Modulo Module	m=2.1166
Diametro interno Minor diameter	Di=23.0 $\begin{matrix} +0.033 \\ 0 \end{matrix}$
Diametro esterno Major diameter	De=28.0 $\begin{matrix} 0 \\ -0.1 \end{matrix}$
Misura massima tra i rullini* Max measurement between pins*	17.62 $\begin{matrix} +0.15 \\ 0 \end{matrix}$
Diametro rullini Pins diameter	4.835 $\pm 0.001$
* Dimensioni definitive dopo il trattamento * Finished dimensions (when hardened)	

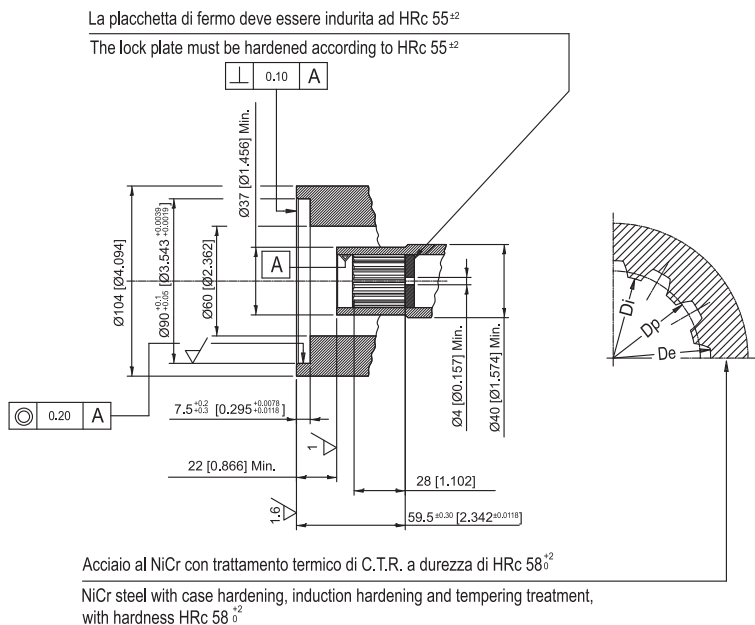

## ALBERO CILINDRICO CL254 CL254 CYLINDRICAL SHAFT

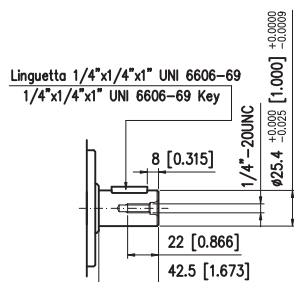

Coppia max ammissibile (Cont. 300 Nm - Int. 410 Nm)  
Max. admissible Torque (Cont. 300 Nm [221 lbf-ft] - Int. 410 Nm [302 lbf-ft])

## ALBERO CILINDRICO CL025 CL025 CYLINDRICAL SHAFT

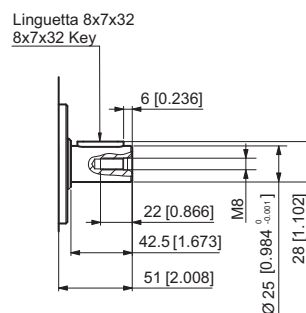

Coppia max ammissibile (Cont. 300 Nm - Int. 410 Nm)  
Max. admissible Torque (Cont. 300 Nm [221 lbf-ft] - Int. 410 Nm [302 lbf-ft])

## ALBERO SCANALATO SE250 SE250 SPLINED SHAFT

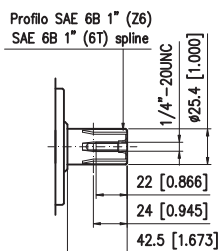

Coppia max ammissibile (Cont. 360 Nm - Int. 450 Nm)  
Max. admissible Torque (Cont. 360 Nm [265 lbf-ft] - Int. 450 Nm [332 lbf-ft])

## ALBERO CILINDRICO C3175 C3175 CYLINDRICAL SHAFT

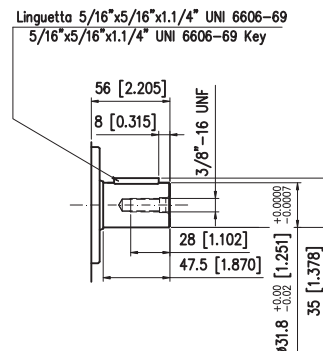

Coppia max ammissibile (Cont. 768 Nm)  
Max. admissible Torque (Cont. 768 Nm [566 lbf-ft])

## ALBERO SCANALATO SC320 SC320 SPLINED SHAFT

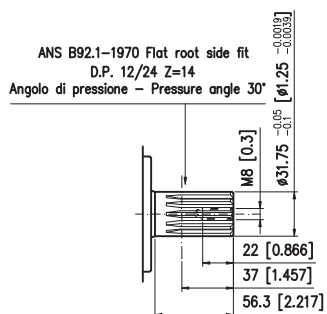

Coppia max ammissibile (Cont. 768 Nm)  
Max. admissible Torque (Cont. 768 Nm [566 lbf-ft])

## ALBERO CILINDRICO CL320 CL320 CYLINDRICAL SHAFT

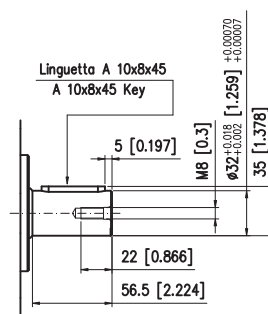

Coppia max ammissibile (Cont. 768 Nm)  
Max. admissible Torque (Cont. 768 Nm [566 lbf-ft])



**ALBERO SCANALATO SE320  
SE320 SPLINED SHAFT**

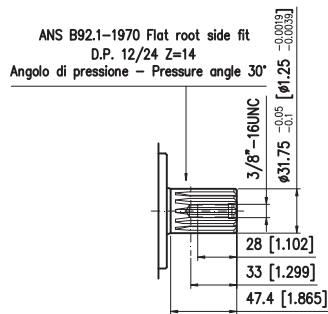

Coppia max ammissibile (Cont. 768 Nm)  
Max. admissible Torque (Cont. 768 Nm [566 lbf-ft])

**ALBERO CONICO CN320  
CN320 TAPERED SHAFT**

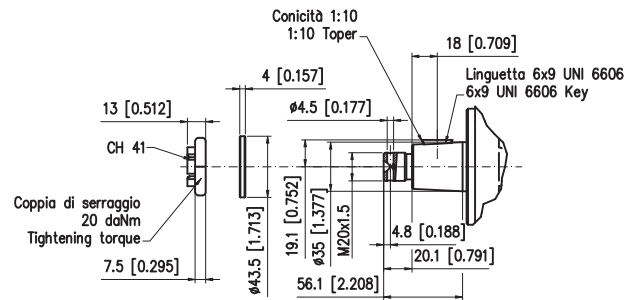

Coppia max ammissibile (Cont. 860 Nm)  
Max. admissible Torque (Cont. 860 Nm [633.82 lbf-ft])

**ALBERO SCANALATO SE350  
SE350 SPLINED SHAFT**

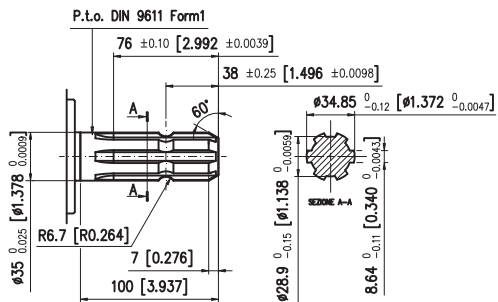

Coppia max ammissibile (Cont. 860 Nm)  
Max. admissible Torque (Cont. 860 Nm [633.82 lbf-ft])

# DIMENSIONI ATTACCHI E SENSO DI ROTAZIONE MAIN PORTS DIMENSIONS AND DIRECTION OF ROTATION

## ATTACCHI TIPO M09 MAIN PORTS TYPE M09

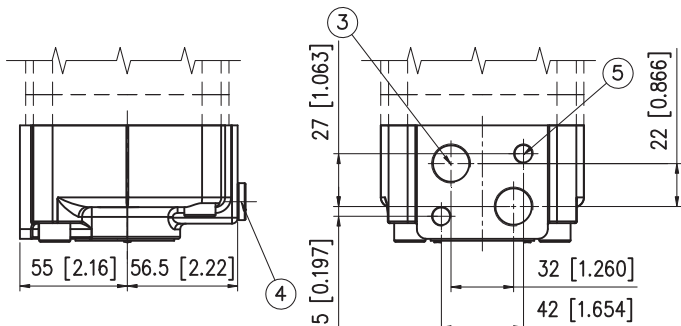

- 3) N° 2 Fori di alimentazione 1/2 G (BSPP) profondità filetto 15mm  
N° 2 Bolts 1/2 G (BSPP) main ports thread depth [0.59 in]
- 4) Drenaggio motore 1/4 G (BSPP) profondità filetto 13mm  
1/4 G (BSPP) drain port thread depth [0.511 in]
- 5) N° 2 M10 profondità filetto 15mm  
N° 2 M10 thread depth [0.59 in]

**Versione S**  
S Version

**Versione C**  
C Version

**Versione W**  
W Version

**Versione F**  
F Version

**Versione L**  
L Version

**Versione M**  
M Version

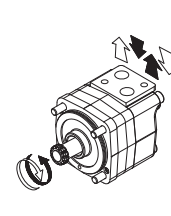
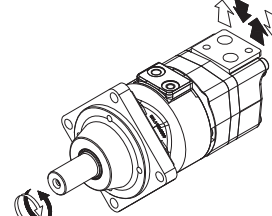
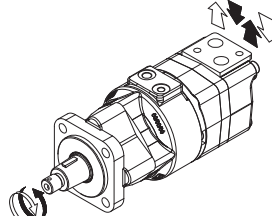
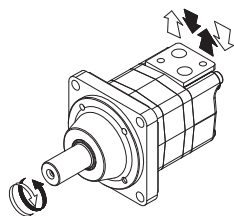
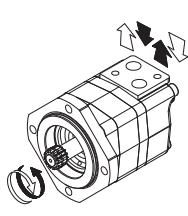
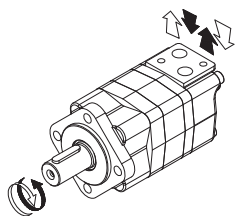

## ATTACCHI TIPO S09 MAIN PORTS TYPE S09

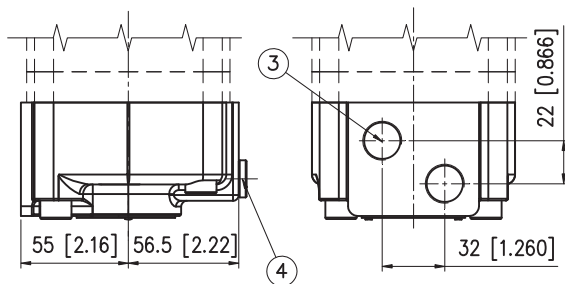

- 3) N° 2 Fori di alimentazione 7/8" - 14 UNF profondità filetto 17mm  
N° 2 Bolts 7/8" - 14 UNF main ports thread depth [0.66 in]
- 4) Drenaggio motore 7/16" - 20 UNF profondità filetto 13mm  
7/16" - 20 UNF drain port thread depth [0.511 in]

**Versione S**  
S Version

**Versione C**  
C Version

**Versione W**  
W Version

**Versione F**  
F Version

**Versione L**  
L Version

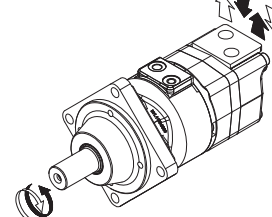
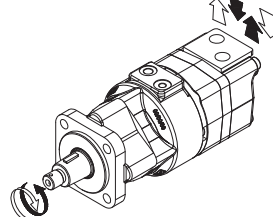
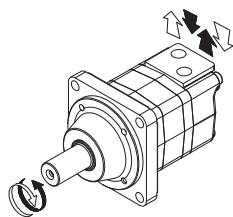
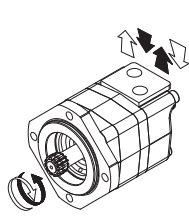
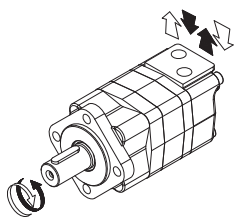

**ATTACCHI LATERALI TIPO L09  
MAIN PORTS POSITIONED 180° APART TYPE L09**

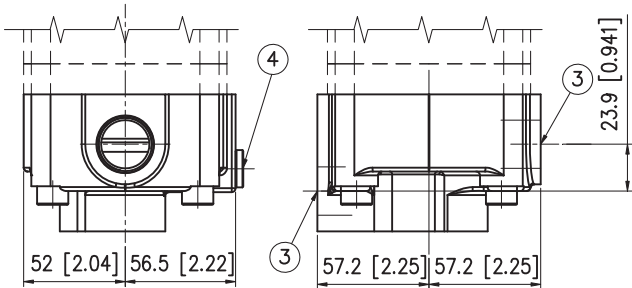

- 3) N° 2 Fori di alimentazione 1" 1/16 - 12 UN profondità filetto 20mm  
N° 2 Bolts 1" 1/16 - 12 UN main ports thread depth [0.78 in]
- 4) Drenaggio motore 7/16" - 20 UNF profondità filetto 13mm  
7/16" - 20 UNF drain port thread depth [0.511 in]

**Versione S  
S Version**

**Versione C  
C Version**

**Versione W  
W Version**

**Versione F  
F Version**

**Versione L  
L Version**

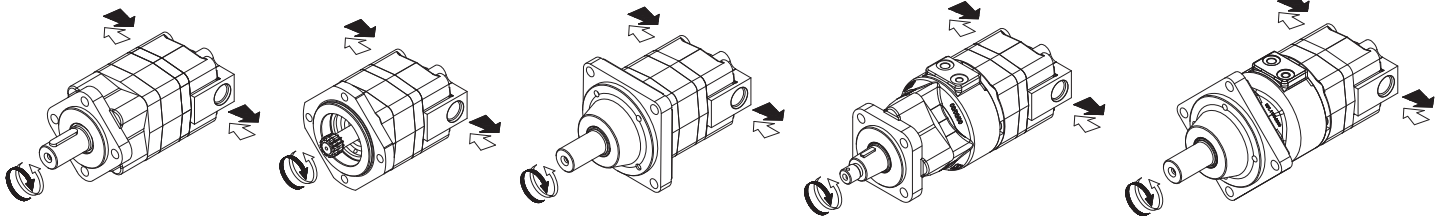

**ATTACCHI FRONTALI TIPO F09  
END MAIN PORTS TYPE F09**

**ATTACCHI FRONTALI TIPO R09  
END MAIN PORTS TYPE R09**

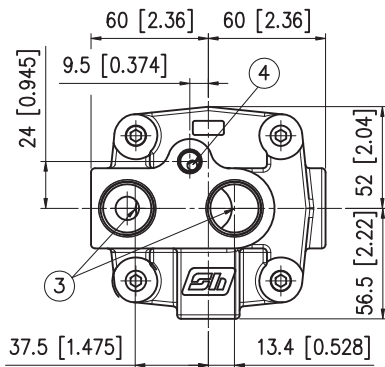

- 3) N° 2 Fori di alimentazione 1" 1/16 - 12 UN profondità filetto 17mm  
N° 2 Bolts 1" 1/16 - 12 UN main ports thread depth [0.66 in]
- 4) Drenaggio motore 7/16" - 20 UNF profondità filetto 13mm  
7/16" - 20 UNF drain port thread depth [0.511 in]

**A RICHIESTA  
UPON REQUEST**

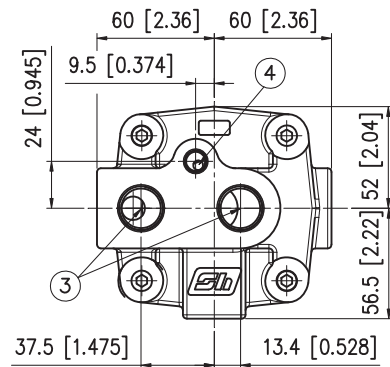

- 3) N° 2 Fori di alimentazione 7/8" - 14 UNF profondità filetto 17mm  
N° 2 Bolts 7/8" - 14 UNF main ports thread depth [0.66 in]
- 4) Drenaggio motore 7/16" - 20 UNF profondità filetto 13mm  
7/16" - 20 UNF drain port thread depth [0.511 in]

**Versione S  
S Version**

**Versione C  
C Version**

**Versione W  
W Version**

**Versione F  
F Version**

**Versione L  
L Version**

**Versione M  
M Version**

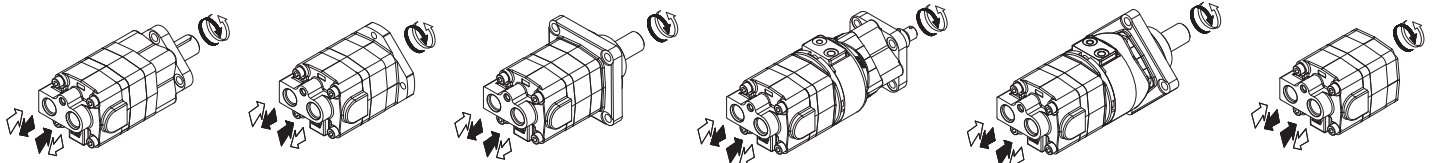

### ATTACCO DRENAGGIO SECONDARIO (LATO MANDATA) SECONDARY DRAIN PORT (AT DELIVERY SIDE)

Per i motori con versione S-W è possibile inserire un secondario attacco di drenaggio (lato mandata).

Se si vuole predisporre il motore con un secondario attacco di drenaggio è necessario specificare in fase d'ordine il valore "OKK" per versione metrica o "SKK" per versione SAE (vedere punto 12 del codice di ordinazione).

For the motor with S-W version, it is possible to put a secondary drain port (at delivery side).

If it is necessary on the motor a secondary drain port, to specify in the purchase order the value "OKK" for metric version or "SKK" for SAE version (See position 12 of ordering code)

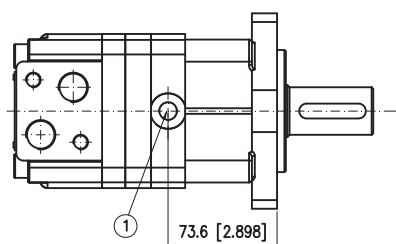

**Versione S  
S Version**

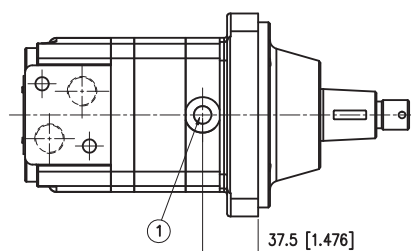

**Versione W  
W Version**

- 1) Drenaggio motore 1/4 G (BSPP) (OK)  
1/4 G (BSPP) drain port (OK)  
Drenaggio motore 7/16" - 20 UNF (SK)  
7/16" - 20 UNF drain port (SK)

### BASSI TRAFILAMENTI LOW LEAKAGE

E' raccomandata la versione Bassi Trafilamenti, in caso di applicazioni a basse portate e contemporaneamente alta pressione di esercizio.

La versione Bassi Trafilamenti, differisce dalla versione Standard, per dei componenti interni differenti.

For applications with low flow and high working pressure, it is recommended the Low Leakage version.

The Low Leakage version differs from the standard version for the different internal components.

### COPERCHIO SPECIALE PER VALVOLA DI LAVAGGIO SPECIAL COVER FOR FLUSHING VALVE

Per il montaggio diretto della valvola di lavaggio sui motori è necessario utilizzare un coperchio speciale.

Questo è possibile solo con gli attacchi "M09 - S09".

Se si vuole predisporre il motore con valvola di lavaggio è necessario specificare in fase d'ordine il tipo di valvola 06-09-15-21 (vedere il punto 10 del codice di ordinazione)

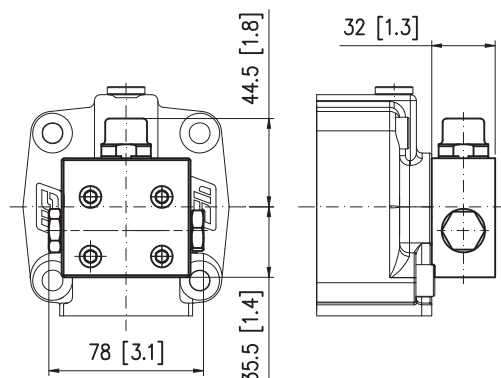

The mount the flushing valve on motors, it is necessary to use a special cover.

This is only possible with the "M09 - S09" main ports.

If it is necessary to assembly the flushing valve on motors, to specify in the purchase order the valves type 06-09-15-21 (See position 10 of ordering code)

Per maggiori informazioni sulla valvola di lavaggio, consultare la sezione Valvole ed Accessori o il Bollettino Informativo 05-0082-A04  
For more informations on the Flushing valve, see the Valves and Accessories section or Service Bulletin - 05-0082-A04

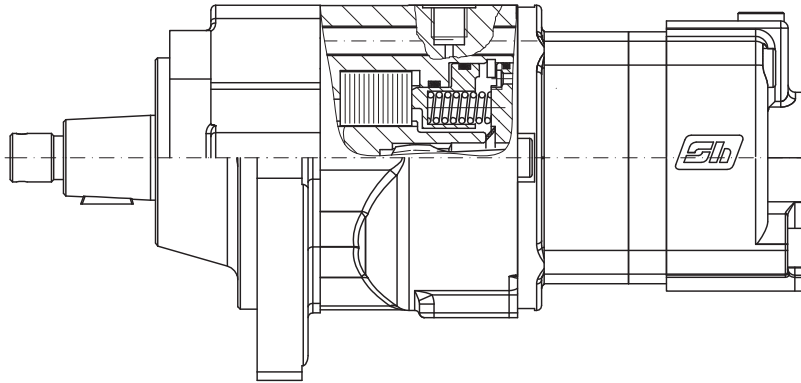

Pressione di apertura minima Starting release pressure	25 bar [362 psi]
Pressione freno libero Full release pressure	30 bar [435 psi]
Pressione comando freno Max. Brake control pressure Max.	210 bar [3045 psi]

MOTORE MOTOR	COPPIA STATICA DI FRENATURA STATIC BRAKING TORQUE			
	STANDARD	12 MOLLE / 10 CONTATTI 12 SPRINGS / 10 CONTACTS	8 MOLLE 8 SPRINGS	COPPIA MAGGIORATA INCREASED BRAKING TORQUE
Versione F - Versione L 080 F Version - L Version 080	210 Nm [154.7 lbf-ft]			
Versione F - Versione L 100 F Version - L Version 100	280 Nm [206.3 lbf-ft]	259 Nm [190.8 lbf-ft]		
Versione F - Versione L 130 F Version - L Version 130	340 Nm [250.5 lbf-ft]			
Versione F - Versione L 160 F Version - L Version 160	340 Nm [250.5 lbf-ft]			
Versione F - Versione L 200 F Version - L Version 200	420 Nm [309.5 lbf-ft]			560 Nm [412.7 lbf-ft]
Versione F - Versione L 250 F Version - L Version 250	470 Nm [346.3 lbf-ft]		313 Nm [230.6 lbf-ft]	560 Nm [412.7 lbf-ft]
Versione F - Versione L 315 F Version - L Version 315	560 Nm [412.7 lbf-ft]	259 Nm [190.8 lbf-ft]	373 Nm [274.9 lbf-ft]	
Versione F - Versione L 400 F Version - L Version 400	560 Nm [412.7 lbf-ft]		373 Nm [274.9 lbf-ft]	

I freni integrati dei motori-freno versione F e versione L sono del tipo multidisco a sblocco sotto pressione per uso in condizioni statiche. Quando l'olio proveniente dalla pompa non è in pressione, una serie di molle mantiene premuti i dischi gli uni contro gli altri; pertanto, l'albero del motore non potrà ruotare se non trascinato da una coppia che ecceda di molto la massima coppia di frenatura statica del freno. Inviando olio al motore, una valvola di commutazione (da inserire nell'impianto) devia al freno parte del flusso, vincendo così la resistenza delle molle che, sbloccando il freno, consentono la partenza del motore. I motori ruota necessitano di alcune attenzioni per quanto riguarda la progettazione della macchina da azionare. Gli aspetti più importanti da considerare sono:

- 1) Le conicità di mozzo ed albero motore devono combaciare perfettamente, in modo da evitare sovraccarichi sulla chiavetta, che potrebbero verificarsi qualora la rondella dell'albero andasse in appoggio sulla fine della parte conica dell'albero.
- 2) In caso di urti all'albero (come nel caso di macchine mobili che traslano su terreno sconnesso) si dovrà considerare un adeguato fattore di servizio.
- 3) I motori-freno versione L che azionano macchine mobili dovrebbero sempre essere protetti da una valvola doppia overcentre con commutatore, flangiata in modo da assicurare un sicuro rallentamento della macchina e l'entrata in funzione del freno all'arresto.

The brakes built into F version and L version motors are multidisc pressure released ones for static operation. With no pressure from the pump to the motor, a set of springs will push the discs one against the other, hence the motor shaft will not be allowed to rotate unless the shaft itself is driven with a torque widely exceeding the max. static torque of the brake. By sending pressure to the motor a shuttle valve (to be included in the system) will send pressure to the brake, overcome the resistance of the springs and release the brake hence allowing the start of the motor. Wheel motors require some care in the engineering of the machine. The major aspects to consider are:

- 1) Hub and motor shaft tapers must be perfectly matching, in order to avoid excessive key stress, which can occur in case of bottoming of shaft tip washer and nut at the end of the thread.
- 2) A proper service factor should be considered in case of shocks to the shaft (eg. With the machine travelling on very uneven soil).
- 3) L version brake motors operating mobile machines should always have a flanged on double overcentre + shuttle valve, in order to ensure safe slow-down of the machine and engaging of brake when a complete stop has been reached.

**CIRCUITO APERTO, UN MOTORE FRENO, ROTAZIONE IN ENTRAMBE LE DIREZIONI ED AZIONAMENTO FRENO AUTOMATICO.**

Questa è la tipica configurazione di un sistema di rotazione (gru, escavatori, piattaforme mobili, falconi, etc.). Quando la pompa invia olio al motore la pressione aziona la valvola di commutazione che, attivando la linea del freno, ne consente il rilascio. La valvola doppia overcentre rallenta la massa in rotazione fino quasi all'arresto, quando entra in azione il freno statico.

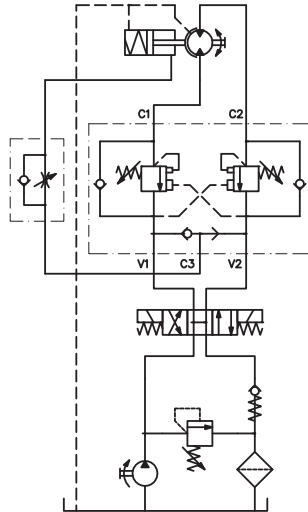

**OPEN LOOP SYSTEM, ONE BRAKE-MOTOR, BI-DIRECTIONAL TURNING AND AUTOMATIC BRAKE OPERATION.**

This configuration is typically that of a slew drive (cranes, excavators, aerial platforms, derricks, etc.). When the pump delivers oil to the motor the consequent generation of pressure will operate the shuttle valve and activate the brake line, thus disengaging the brake itself. When the oil delivery is shut off to stop the machine, a double overcentre valve will slow down the rotative mass to an almost complete stop when the static brake will engage.

**CIRCUITO APERTO, DUE MOTORI FRENO, ROTAZIONE IN ENTRAMBE LE DIREZIONI ED AZIONAMENTO AUTOMATICO DEL FRENO.**

Questo è uno schema abbastanza comune di un impianto di traslazione per macchine mobili (piattaforme aeree, etc.). Il fluido in pressione sblocca il freno e fa partire i due motori; una apposita valvola collega i due motori o in serie o in parallelo in modo da avere più velocità o più coppia. La doppia valvola overcentre rallenta con sicurezza la macchina e la porta fino quasi all'arresto, quando i due freni statici entrano in funzione.

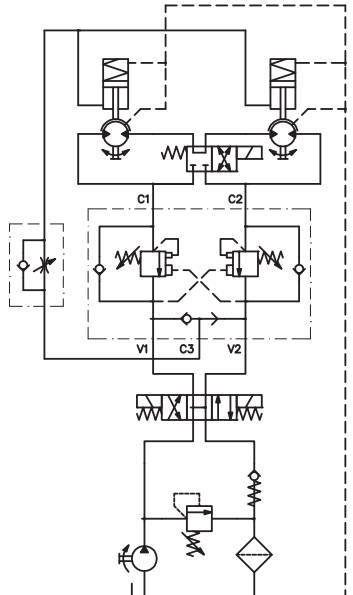

**OPEN LOOP SYSTEM, TWO BRAKE-MOTORS, BI-DIRECTIONAL TURNING AND AUTOMATIC BRAKES OPERATION.**

This is a typical layout of the travelling system of a mobile machine (aerial platforms, etc.). Fluid under pressure disengages the brakes and starts the two motors; a commutation device will connect the two motors either in series or parallel mode in order to have either speed or torque as main performance. The double overcentre valve will steadily slow down the machine and bring it to an almost complete stop when the brakes will engage.

**CIRCUITO CHIUSO, UN MOTORE FRENO, ROTAZIONE IN ENTRAMBE LE DIREZIONI, FRENATURA AUTOMATICA, POMPA A PORTATA VARIABILE.**

Questo è un tipico impianto di traslazione per spazzatrici ad una ruota motrice. La pompa impiegata consente di azionare il motore a velocità variabile. Il freno viene sbloccato dall'invio di olio dalla valvola commutatrice attraverso l'elettrovalvola che consente anche il deflusso del fluido in pressione dalla camera del freno quando il motore si arresta ed in freno stesso entra in azione.

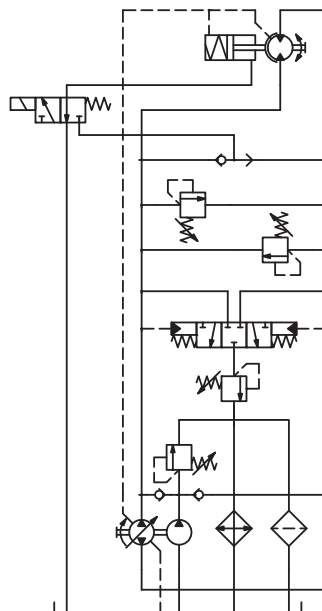

**CLOSED LOOP SYSTEM, ONE BRAKE-MOTOR, BI-DIRECTIONAL TURNING, AUTOMATIC BRAKE OPERATION AND VARIABLE PUMP.**

A very typical system for sweepers. The pump delivers a variable flow of oil to the motor hence the machine can travel at variable speed. The brake is disengaged by the delivery of flow from the shuttle valve via the electrovalve (top, right) that will also release the fluid under pressure from inside the brake piston chamber when the motor stops and the brake engages.

**Versione S - Versione F**  
**S Version - F Version**

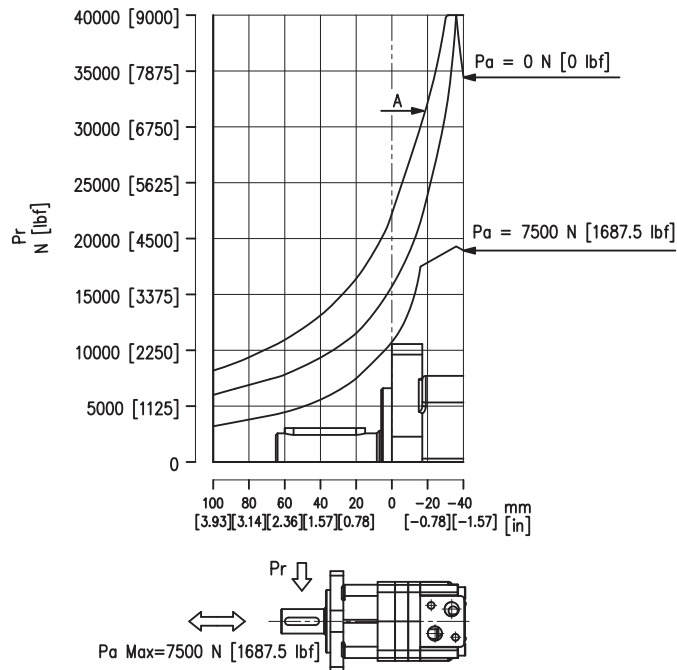

*Il diagramma dei carichi è valido per una vita dei cuscinetti  $L_{10h}$  di 1600 ore alla velocità di 200 giri/min quando viene utilizzato olio a base minerale minerale con un adeguato contenuto di additivi anti usura. La vita dei cuscinetti è stata calcolata con un grado di affidabilità del 90%.*  
*La curva "A" fornisce il carico radiale limite sopportato dai cuscinetti in condizioni di carico statico massimo.*

**Versione W - Versione L**  
**W Version - L Version**

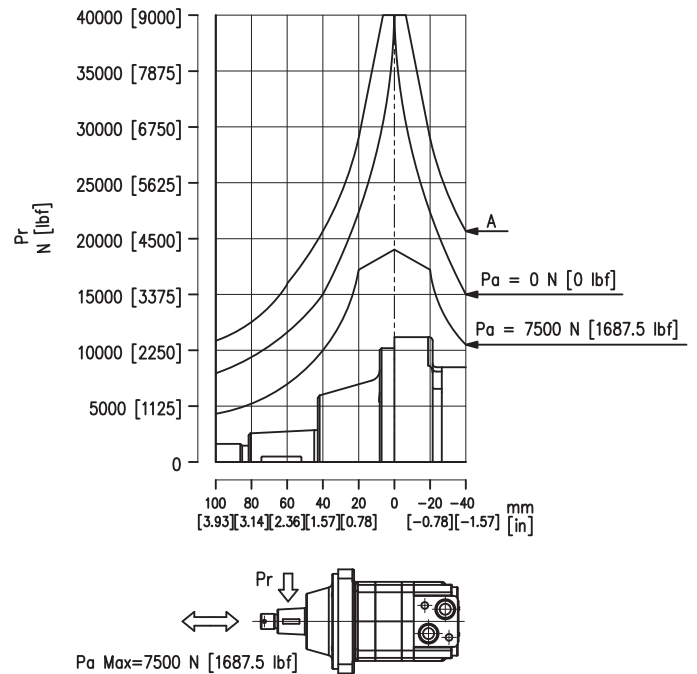

Loads diagram is for a bearings life  $L_{10h}$  of 1600 hours at 200 rpm when mineral base hydraulic oil with a sufficient content of anti-wear additives is used. Bearing life calculation refers to a 90% degree of reliability.  
 Curve "A" shows the maximum radial load that can be taken by the bearings under maximum static load duty.



# HR 080

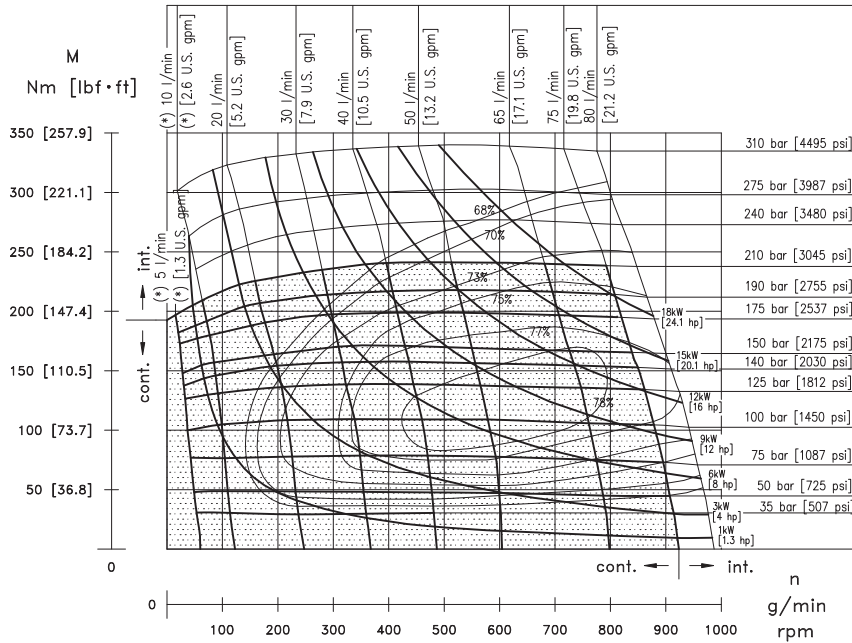

Pressioni e portate superiori a quelle ammesse in regime continuo non devono essere applicate contemporaneamente.  
Exceeding continuous pressure values or exceeding flow values indicated, must not occur simultaneously.

(\* ) Dati prestazionali riferiti a motori standard. Per ottenere prestazioni superiori, quando il motore viene utilizzato con portata inferiore a 10 l/min, utilizzare versione LW (Low Leakage).  
Performances data are referred to standard motors. For obtain higher performances, when the motor is used with flow < 10 l/min [< 2.64 U.S. gpm], we suggest to use LW (Low Leakage) version.

# HR 100

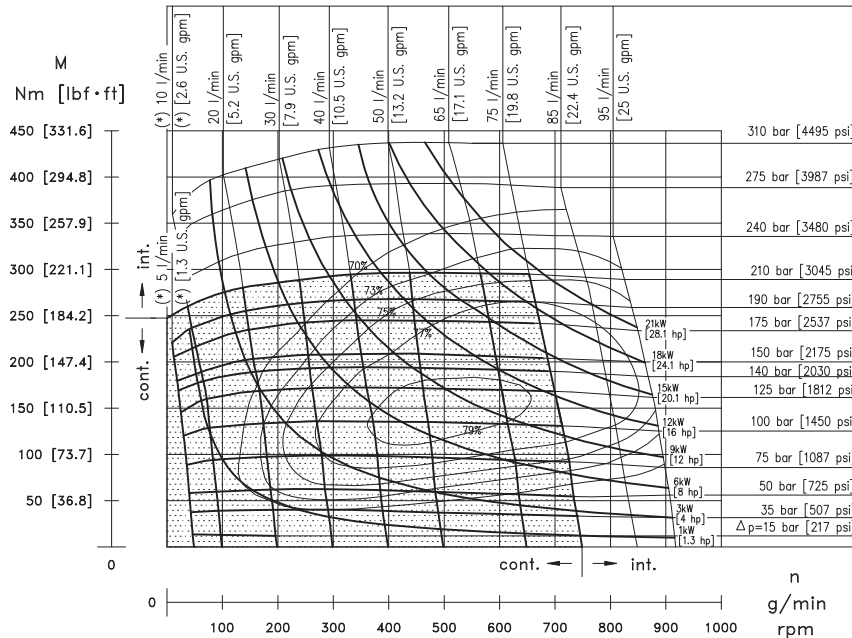

Pressioni e portate superiori a quelle ammesse in regime continuo non devono essere applicate contemporaneamente.  
Exceeding continuous pressure values or exceeding flow values indicated, must not occur simultaneously.

(\* ) Dati prestazionali riferiti a motori standard. Per ottenere prestazioni superiori, quando il motore viene utilizzato con portata inferiore a 10 l/min, utilizzare versione LW (Low Leakage).  
Performances data are referred to standard motors. For obtain higher performances, when the motor is used with flow < 10 l/min [< 2.64 U.S. gpm], we suggest to use LW (Low Leakage) version.



# HR 130

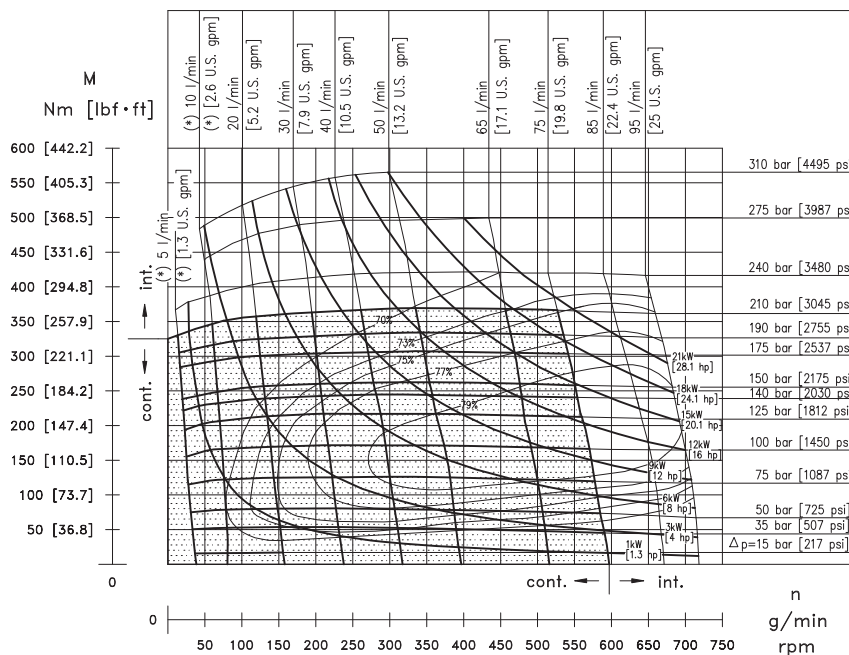

Pressioni e portate superiori a quelle ammesse in regime continuo non devono essere applicate contemporaneamente.  
Exceeding continuous pressure values or exceeding flow values indicated, must not occur simultaneously.

(\*) Dati prestazionali riferiti a motori standard. Per ottenere prestazioni superiori, quando il motore viene utilizzato con portata inferiore a 10 l/min, utilizzare versione LW (Low Leakage).  
Performances data are referred to standard motors. For obtain higher performances, when the motor is used with flow < 10 l/min [< 2.64 U.S. gpm], we suggest to use LW (Low Leakage) version.

# HR 160

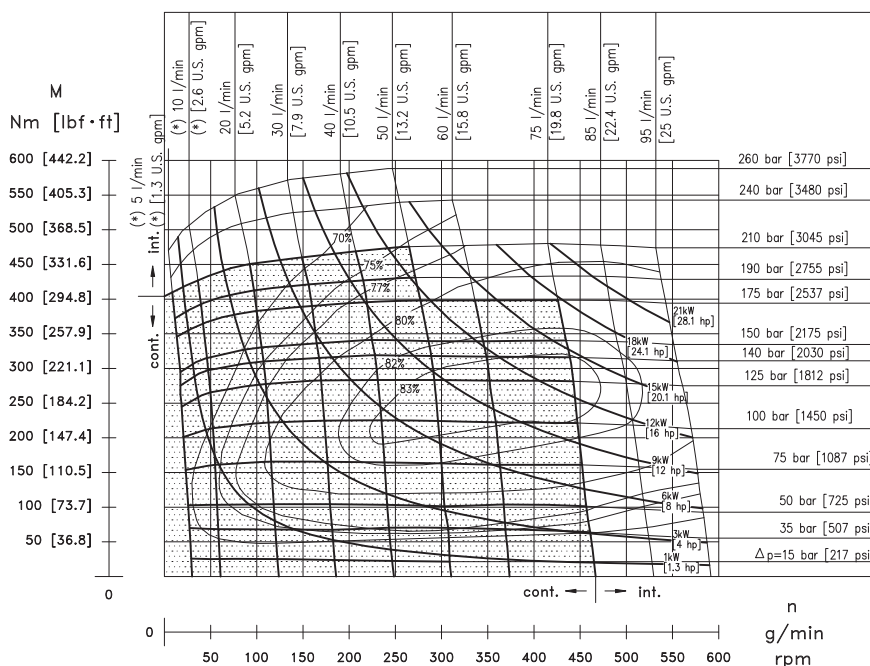

Pressioni e portate superiori a quelle ammesse in regime continuo non devono essere applicate contemporaneamente.  
Exceeding continuous pressure values or exceeding flow values indicated, must not occur simultaneously.

(\*) Dati prestazionali riferiti a motori standard. Per ottenere prestazioni superiori, quando il motore viene utilizzato con portata inferiore a 10 l/min, utilizzare versione LW (Low Leakage).  
Performances data are referred to standard motors. For obtain higher performances, when the motor is used with flow < 10 l/min [< 2.64 U.S. gpm], we suggest to use LW (Low Leakage) version.

# HR 200

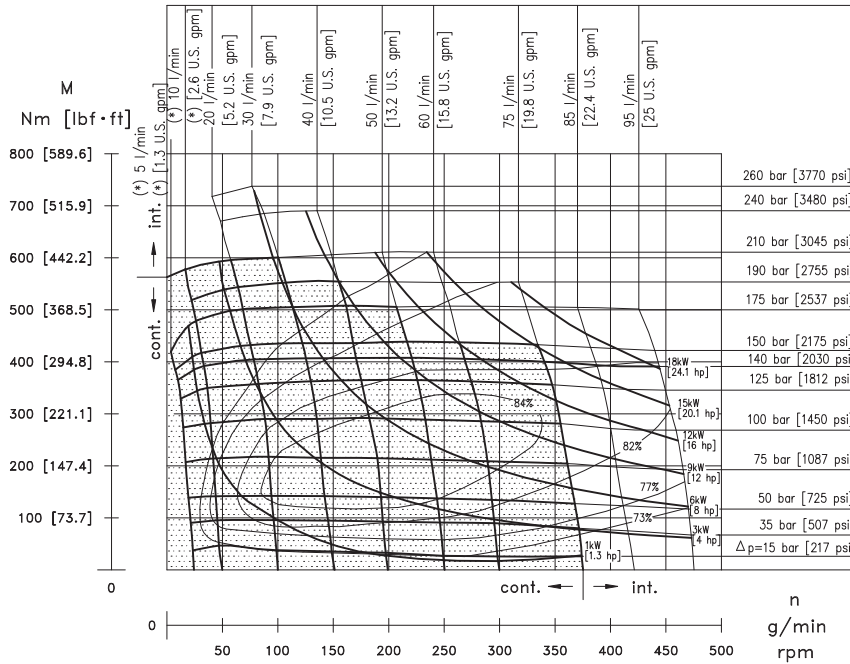

Pressioni e portate superiori a quelle ammesse in regime continuo non devono essere applicate contemporaneamente.  
Exceeding continuous pressure values or exceeding flow values indicated, must not occur simultaneously.

(\*) Dati prestazionali riferiti a motori standard. Per ottenere prestazioni superiori, quando il motore viene utilizzato con portata inferiore a 10 l/min, utilizzare versione LW (Low Leakage).  
Performances data are referred to standard motors. For obtain higher performances, when the motor is used with flow < 10 l/min [< 2.64 U.S. gpm], we suggest to use LW (Low Leakage) version.

# HR 250

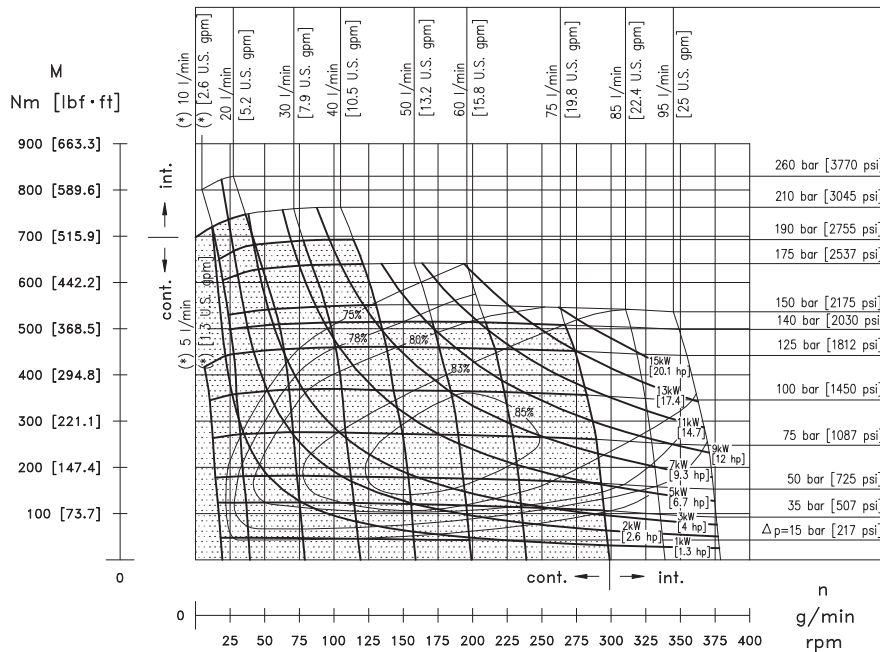

Pressioni e portate superiori a quelle ammesse in regime continuo non devono essere applicate contemporaneamente.  
Exceeding continuous pressure values or exceeding flow values indicated, must not occur simultaneously.

(\*) Dati prestazionali riferiti a motori standard. Per ottenere prestazioni superiori, quando il motore viene utilizzato con portata inferiore a 10 l/min, utilizzare versione LW (Low Leakage).  
Performances data are referred to standard motors. For obtain higher performances, when the motor is used with flow < 10 l/min [< 2.64 U.S. gpm], we suggest to use LW (Low Leakage) version.

# HR 315

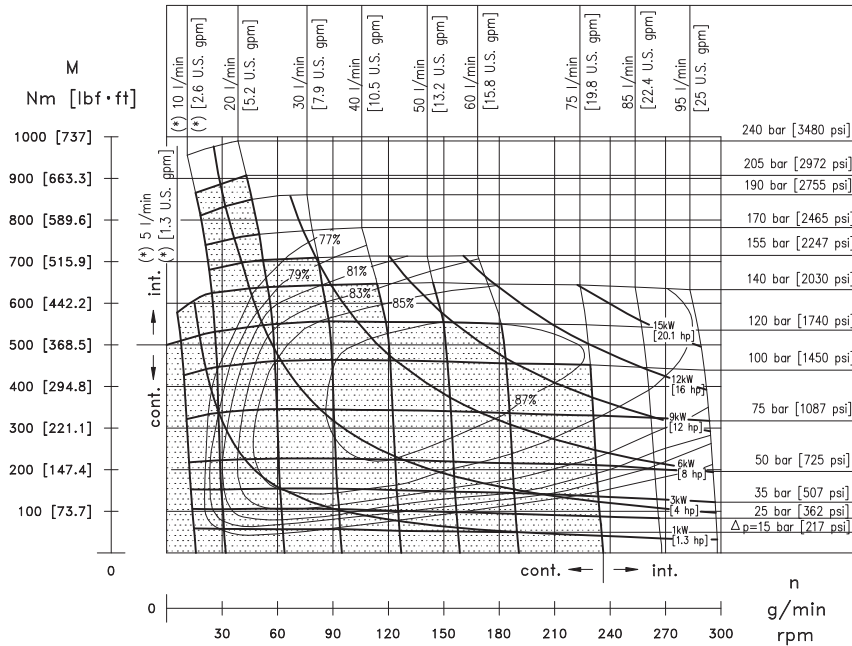

Pressioni e portate superiori a quelle ammesse in regime continuo non devono essere applicate contemporaneamente.  
Exceeding continuous pressure values or exceeding flow values indicated, must not occur simultaneously.

(\* ) Dati prestazionali riferiti a motori standard. Per ottenere prestazioni superiori, quando il motore viene utilizzato con portata inferiore a 10 l/min, utilizzare versione LW (Low Leakage).  
Performances data are referred to standard motors. For obtain higher performances, when the motor is used with flow < 10 l/min [< 2.64 U.S. gpm], we suggest to use LW (Low Leakage) version.

# HR 400

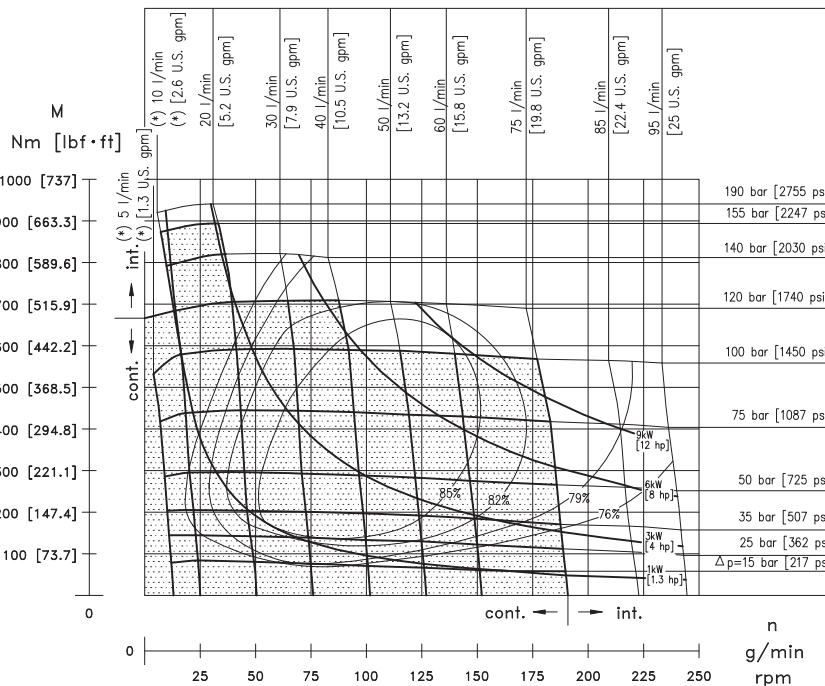

Pressioni e portate superiori a quelle ammesse in regime continuo non devono essere applicate contemporaneamente.  
Exceeding continuous pressure values or exceeding flow values indicated, must not occur simultaneously.

(\* ) Dati prestazionali riferiti a motori standard. Per ottenere prestazioni superiori, quando il motore viene utilizzato con portata inferiore a 10 l/min, utilizzare versione LW (Low Leakage).  
Performances data are referred to standard motors. For obtain higher performances, when the motor is used with flow < 10 l/min [< 2.64 U.S. gpm], we suggest to use LW (Low Leakage) version.





**BREVINI<sup>®</sup>**

*Motion Systems*

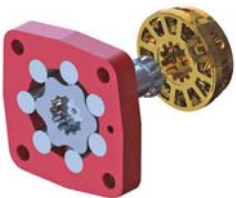
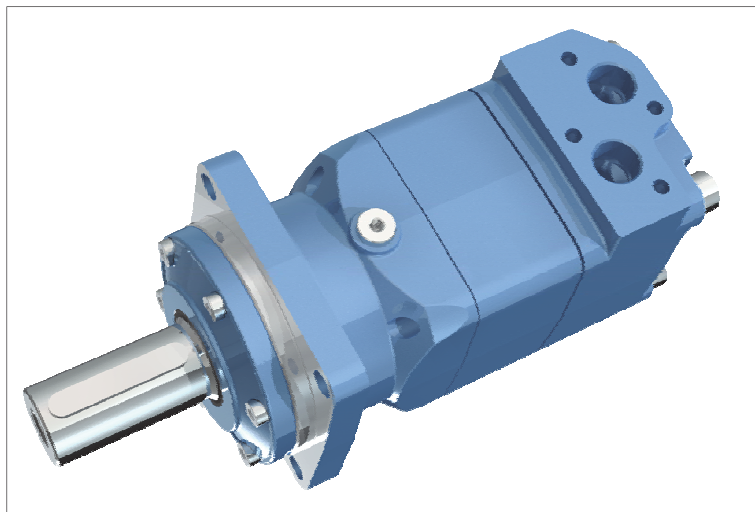

**HT**

***MOTORI ORBITALI***

**ORBITAL MOTORS**

# CARATTERISTICHE DEL MOTORE MOTOR FEATURES

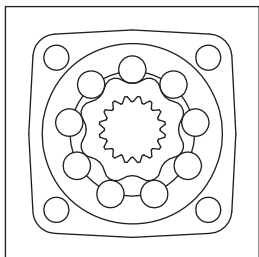
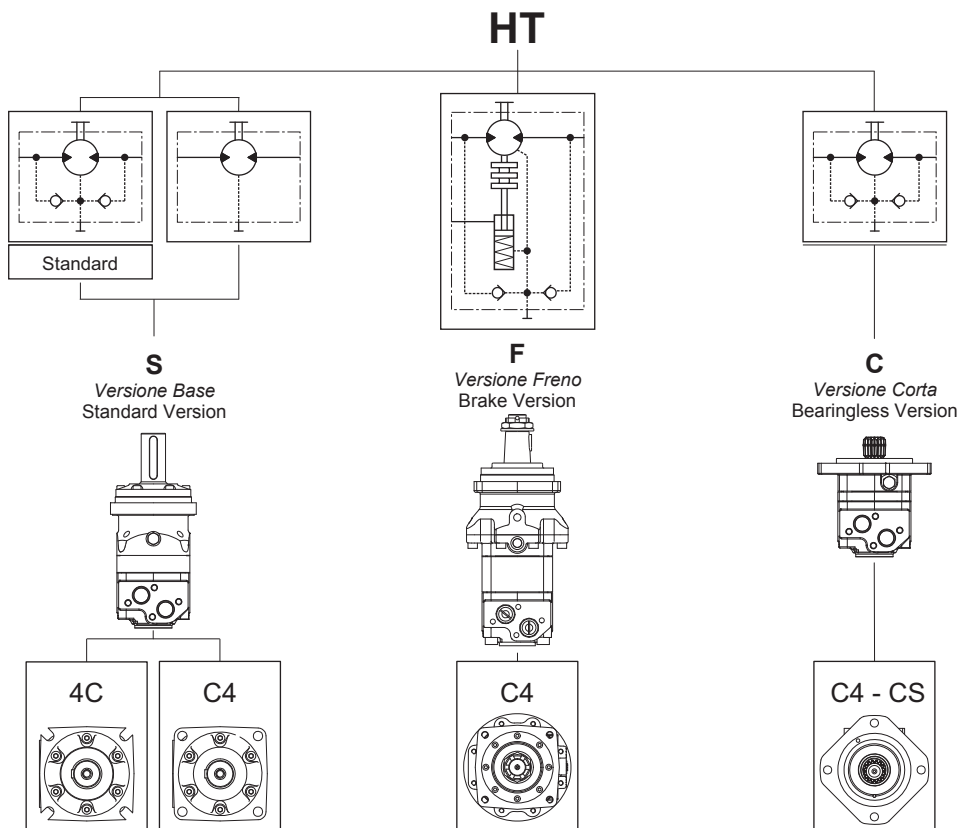

*Organo motore roller che consente elevate pressioni di esercizio e lunga durata.*  
Heavy duty, roller type stator meant to work at high pressure ant to guarantee extra long lasting.

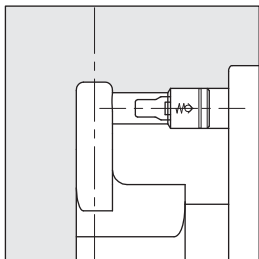

*Valvole di drenaggio incorporate che ricircolano allo scarico il fluido drenato interamente (versione standard).*  
Built-in check valves to recirculate internally drained fluid through return line (standard version).

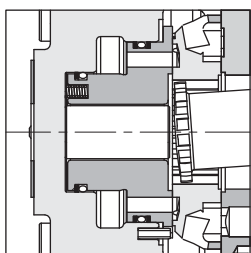

*Distribuzione con valvola a disco con recupero automatico dei giochi effettuato dal fluido in pressione; viene così raggiunto un livello più basso di drenaggio ed un rendimento più elevato. La presenza di tenute con antiestrusore garantisce maggiore affidabilità.*  
Disc valve distribution with automatic compensation of backlash done by fluid under pressure: lower drain figures are then guaranteed together with high efficiency. The presence of seals with back-up ring guarantee greater reliability.

*Comando con semigiunto separato della distribuzione per garantire una precisa fasatura.*  
Separate disc valves drive to guarantee sharp phase.

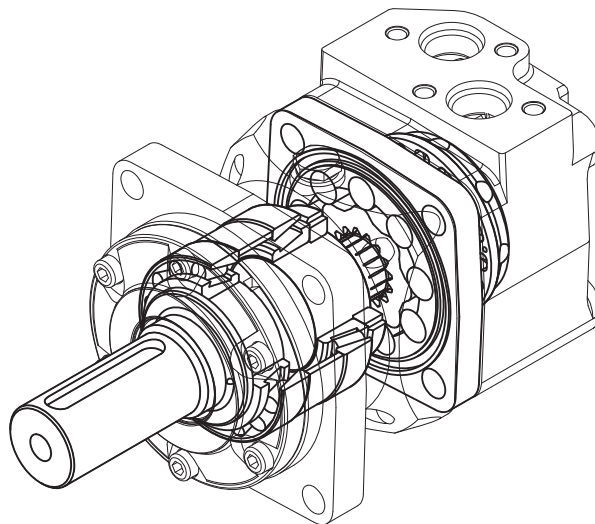

*Albero supportato da due robusti cuscinetti a rulli conici che assicurano una grande tenuta ai carichi.*  
Shaft supported by two heavy duty tapered roller bearings that ensure outstanding radial load capacity.

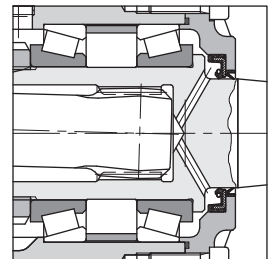

# CARATTERISTICHE TECNICHE TECHNICAL SPECIFICATIONS

Motore Motor	Cilindrata Displacement cm <sup>3</sup> /giro [in <sup>3</sup> /rev]	Max. pressione in ingresso Max. input pressure bar [psi]		Pressione diff. max. Max. differential pressure bar [psi]		Coppia max. Max. torque Nm [lbf-ft]		Portata max. Max. flow l/min [U.S. gpm]		Velocità max. Max. speed rpm		Potenza max. Max. power kW [hp]	
		Cont Int <sup>1)</sup> Peak <sup>2)</sup>	210 [3045] 250 [3625] 300 [4350]	Cont Int <sup>1)</sup> Peak <sup>2)</sup>	200 [2900] 240 [3480] 280 [4060]	Cont Int <sup>1)</sup> Peak <sup>2)</sup>	470 [346.3] 560 [412.7] 660 [486.4]	Cont Int <sup>1)</sup>	100 [26.4] 125 [33]	Cont Int <sup>1)</sup>	625 780	Cont Int <sup>1)</sup>	27.5 [36.8] 32 [42.8]
HT 160	161.1 [9.8]	Cont Int <sup>1)</sup> Peak <sup>2)</sup>	210 [3045] 250 [3625] 300 [4350]	Cont Int <sup>1)</sup> Peak <sup>2)</sup>	200 [2900] 240 [3480] 280 [4060]	Cont Int <sup>1)</sup> Peak <sup>2)</sup>	470 [346.3] 560 [412.7] 660 [486.4]	Cont Int <sup>1)</sup>	100 [26.4] 125 [33]	Cont Int <sup>1)</sup>	625 780	Cont Int <sup>1)</sup>	27.5 [36.8] 32 [42.8]
HT 200	201.4 [12.2]	Cont Int <sup>1)</sup> Peak <sup>2)</sup>	210 [3045] 250 [3625] 300 [4350]	Cont Int <sup>1)</sup> Peak <sup>2)</sup>	200 [2900] 240 [3480] 280 [4060]	Cont Int <sup>1)</sup> Peak <sup>2)</sup>	590 [434.8] 710 [523.2] 820 [604.3]	Cont Int <sup>1)</sup>	125 [33] 150 [39.6]	Cont Int <sup>1)</sup>	625 750	Cont Int <sup>1)</sup>	33.5 [44.8] 40 [53.6]
HT 250	251.8 [15.3]	Cont Int* Peak <sup>2)</sup>	210 [3045] 250 [3625] 300 [4350]	Cont Int* Peak <sup>2)</sup>	200 [2900] 240 [3480] 280 [4060]	Cont Int* Peak <sup>2)</sup>	730 [538] 880 [648.5] 1020 [751.7]	Cont Int <sup>1)</sup>	125 [33] 150 [39.6]	Cont Int <sup>1)</sup>	500 600	Cont Int <sup>1)</sup>	33.5 [44.8] 40 [53.6]
HT 315	326.3 [19.9]	Cont Int <sup>1)</sup> Peak <sup>2)</sup>	210 [3045] 250 [3625] 300 [4350]	Cont Int <sup>1)</sup> Peak <sup>2)</sup>	200 [2900] 240 [3480] 280 [4060]	Cont Int <sup>1)</sup> Peak <sup>2)</sup>	950 [700.1] 1140 [840.1] 1330 [980.2]	Cont Int <sup>1)</sup>	125 [33] 150 [39.6]	Cont Int <sup>1)</sup>	380 460	Cont Int <sup>1)</sup>	33.5 [44.8] 40 [53.6]
HT 400	410.9 [25.06]	Cont Int <sup>1)</sup> Peak <sup>2)</sup>	210 [3045] 250 [3625] 300 [4350]	Cont Int <sup>1)</sup> Peak <sup>2)</sup>	180 [2610] 210 [3045] 240 [3480]	Cont Int <sup>1)</sup> Peak <sup>2)</sup>	1080 [795.9] 1260 [928.6] 1440 [1061.2]	Cont Int <sup>1)</sup>	125 [33] 150 [39.6]	Cont Int <sup>1)</sup>	305 365	Cont Int <sup>1)</sup>	30 [40.2] 35 [46.9]
HT 500	523.6 [31.9]	Cont Int <sup>1)</sup> Peak <sup>2)</sup>	210 [3045] 250 [3625] 300 [4350]	Cont Int <sup>1)</sup> Peak <sup>2)</sup>	160 [2320] 180 [2610] 210 [3045]	Cont Int <sup>1)</sup> Peak <sup>2)</sup>	1220 [899.1] 1370 [1009.6] 1600 [1179.2]	Cont Int <sup>1)</sup>	125 [33] 150 [39.6]	Cont Int <sup>1)</sup>	240 285	Cont Int <sup>1)</sup>	26.5 [35.5] 30 [40.2]

Motore Motor	Max. pressione di scarico con drenaggio (cont.) Max. Outlet pressure with Drain line (cont.) bar [psi]		Max. Pressione di avviamento a vuoto Max. starting pressure with no load bar [psi]		Coppia minima di spunto Min. starting torque Nm [lbf-ft]		Velocità minima Min. speed [rpm]	
	Cont Int <sup>1)</sup> Peak <sup>2)</sup>	140 [2030] 175 [2537] 210 [3045]	Cont Int <sup>1)</sup> Peak <sup>2)</sup>	10 [145]	A Δp max. At max. Δp	Cont Int <sup>1)</sup>	340 [250.5] 410 [302.1]	10
HT 160	Cont Int <sup>1)</sup> Peak <sup>2)</sup>	140 [2030] 175 [2537] 210 [3045]	Cont Int <sup>1)</sup> Peak <sup>2)</sup>	10 [145]	A Δp max. At max. Δp	Cont Int <sup>1)</sup>	340 [250.5] 410 [302.1]	10
HT 200	Cont Int <sup>1)</sup> Peak <sup>2)</sup>	140 [2030] 175 [2537] 210 [3045]	Cont Int <sup>1)</sup> Peak <sup>2)</sup>	10 [145]	A Δp max. At max. Δp	Cont Int <sup>1)</sup>	430 [316.9] 520 [383.2]	9
HT 250	Cont Int* Peak <sup>2)</sup>	140 [2030] 175 [2537] 210 [3045]	Cont Int* Peak <sup>2)</sup>	10 [145]	A Δp max. At max. Δp	Cont Int <sup>1)</sup>	530 [390.6] 630 [464.3]	8
HT 315	Cont Int <sup>1)</sup> Peak <sup>2)</sup>	140 [2030] 175 [2537] 210 [3045]	Cont Int <sup>1)</sup> Peak <sup>2)</sup>	10 [145]	A Δp max. At max. Δp	Cont Int <sup>1)</sup>	740 [545.3] 890 [655.9]	7
HT 400	Cont Int <sup>1)</sup> Peak <sup>2)</sup>	140 [2030] 175 [2537] 210 [3045]	Cont Int <sup>1)</sup> Peak <sup>2)</sup>	10 [145]	A Δp max. At max. Δp	Cont Int <sup>1)</sup>	840 [619] 970 [714.8]	6
HT 500	Cont Int <sup>1)</sup> Peak <sup>2)</sup>	140 [2030] 175 [2537] 210 [3045]	Cont Int <sup>1)</sup> Peak <sup>2)</sup>	10 [145]	A Δp max. At max. Δp	Cont Int <sup>1)</sup>	950 [700.1] 1060 [781.2]	5

<sup>1)</sup> Le condizioni intermittenti non devono durare più del 10% di ogni minuto. - Intermittent duty must not exceed 10% each minute.

<sup>2)</sup> Le condizioni di picco non devono durare più del 1% di ogni minuto. - Peak duty must not exceed 1% each minute.

<sup>3)</sup> Viscosità dell'olio 35 cSt. - Oil viscosity 35 cSt.



## MASSIMA PRESSIONE AMMESSA SULLA GUARNIZIONE ALBERO MAX PERMISSIBLE SHAFT SEAL PRESSURE

Pressione massima di scarico senza drenaggio o massima pressione nella linea di drenaggio.

I motori sono forniti nella versione con guarnizioni standard (diagramma Standard) o nella versione con guarnizioni ad alta pressione (diagramma HPS).

Per condizioni di pressione e velocità non contemplate dal presente grafico si consiglia di contattare Dana Brevini.

Max. return pressure without drain line or max. pressure in the drain line.

Motor are supplied in standard seal version (Standard chart) or in HPS seal version (HPS chart).

For pressure and speeds not showed in the curve below, please contact Dana Brevini.

### STANDARD

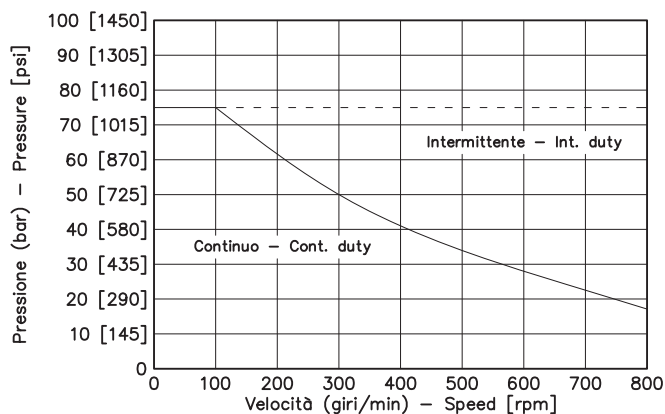

### HPS

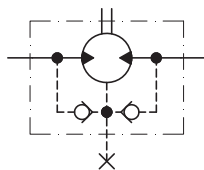
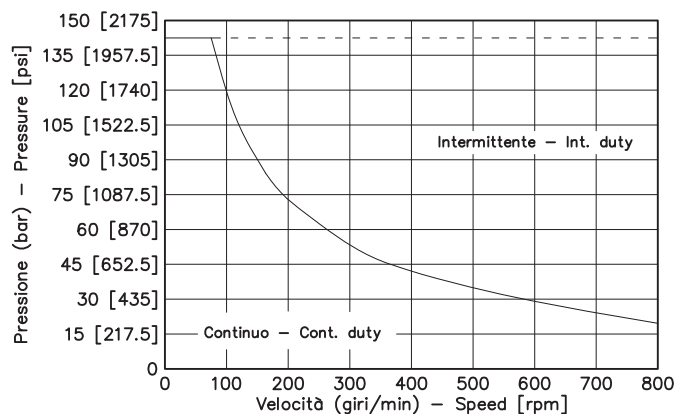

## PERDITE DI CARICO PER ATTRAVERSAMENTO PRESSURE LOSS

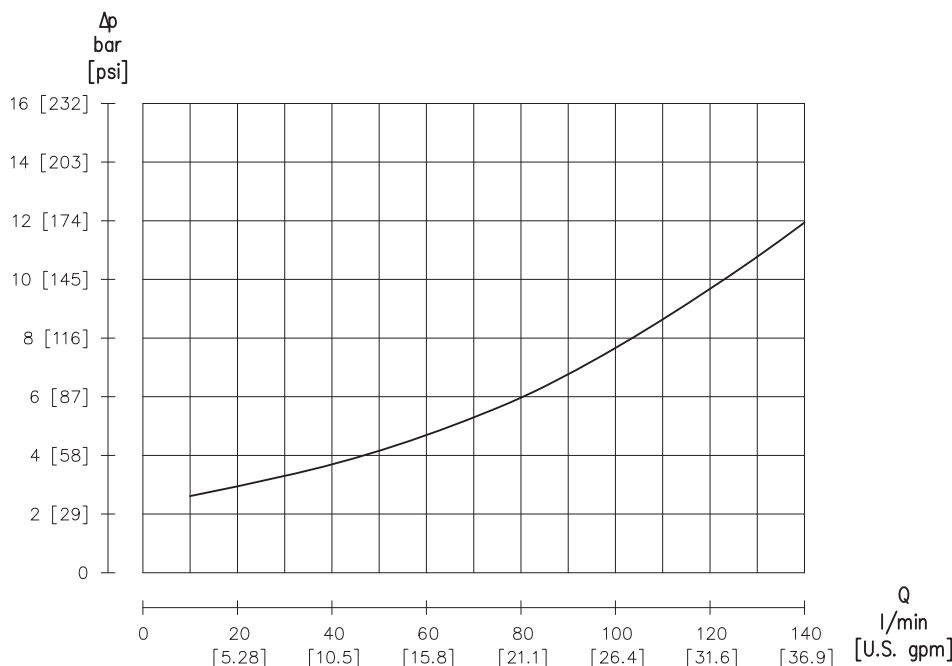

Il diagramma è stato ottenuto con prove eseguite su un numero significativo di motori, utilizzando un olio avente una viscosità cinematica di 37 cSt alla temperatura di 45 C°.

Diagram according to tests done with a relevant number of motors and using hydraulic oil with kinematic viscosity of 37 cSt at 45 C° temperature.



# CODICI DI ORDINAZIONE ORDERING CODES

Le seguenti lettere o numeri del codice, sono state sviluppate per identificare tutte le configurazioni possibili dei motori HT. Usare il seguente modulo per identificare le caratteristiche desiderate. **Tutte le lettere o numeri del codice devono comparire in fase d'ordine.** Si consiglia di leggere attentamente il catalogo prima di iniziare la compilazione del codice di ordinazione.

The following alphanumeric digits system has been developed to identify all of the configuration options for the HT motors. Use the model code below to specify the desired features. **All alphanumeric digits system of the code must be present when ordering.** We recommend to carefully read the catalogue before filling the ordering code.

## CODICE PRODOTTO / MODEL CODE

1	2	3	4	5	6	7	8	9	10	11	12	13

### 1 - SERIE / SERIES

HT	Motore orbitale Orbital motor
----	----------------------------------

### 2 - CILINDRATA / DISPLACEMENT

160	160 cm <sup>3</sup> /giro [9.76 in <sup>3</sup> /rev]
200	200 cm <sup>3</sup> /giro [12.2 in <sup>3</sup> /rev]
250	250 cm <sup>3</sup> /giro [15.25 in <sup>3</sup> /rev]
315	315 cm <sup>3</sup> /giro [19.215 in <sup>3</sup> /rev]
400	400 cm <sup>3</sup> /giro [24.4 in <sup>3</sup> /rev]
500	500 cm <sup>3</sup> /giro [30.5 in <sup>3</sup> /rev]

### 3 - VERSIONIE/ VERSION

S	Versione Base Standard Version	STANDARD
C	Versione Corta Bearingless Version	
F	Versione Freno Brake Version	

### 4 - FLANGIA / FLANGE

		VERSIONIE/ VERSION		
		S	C	F
4C	SAE C 4 Fori SAE C 4 Bolt	•	/	/
C4	ISO 4 Fori (Ø 125 mm) - Drenaggio 1/4 G (BSPP) ISO 4 Bolt Ø 125 mm [Ø 4.9 in] - Drain port 1/4 G (BSPP)	•	•	•
CS	ISO 4 Fori (Ø 125 mm) - Drenaggio 9/16" - 18 UNF ISO 4 Bolt Ø 125 mm [Ø 4.921 in] - Drain port 9/16" - 18 UNF	/	•	/

• Disponibile - Available / Non Disponibile - Not Available

### 5 - ESTREMITÀ ALBERO / SHAFT END

		VERSIONIE/ VERSION		
		S	C	F
DB002	Semigiunto Z=16 12/24 DP Dog Bone T=16 12/24 DP	/	•	/
CL400	Albero Cilindrico Ø40 mm Ø40 mm [1.56 in] Parallel keyed	•	/	•
C3800	Albero Cilindrico Ø38 mm Ø38 mm [1.48 in] Parallel keyed	•	/	/
CN400	Albero Conico (Disponibile solo con flangia C4 e attacchi M10) Tapered Shaft (Available only with mount flange C4 and M10 Main Ports)	•	/	•
SC380	Albero Scanalato (profilo ANS B 92.1 / 1970 12/24 DP Z=17) Splined Shaft (ANS B 92.1 / 1970 12/24 DP Z=17 spline)	•	/	•

• Disponibile - Available / Non Disponibile - Not Available

1	2	3	4	5	6	7	8	9	10	11	12	13
---	---	---	---	---	---	---	---	---	----	----	----	----

#### 6 - ATTACCO / MAIN PORT

		VERSIONE/ VERSION		
		S	C	F
M10	Attacchi 3/4 G BSPP (23x40) 3/4 G BSPP (23x40) Main Ports	•	•	•
S10	Attacchi 1" 1/16 - 12 UN 1" 1/16 - 12 UN Main Ports	•	•	/

• Disponibile - Available / Non Disponibile - Not Available

#### 7 - TENUTE / SEALS

N	NBR	STANDARD
V	FKM	

#### 8 - VALVOLA / VALVE

		ATTACCO / MAIN PORT	
		M10	S10
XXXX	Non Richieste Not Required	•	•
M101	Valvola di massima pressione VAF 10 - D Pressure relief valve VAF 10 - D	•	/
M102	Valvola di controllo bilanciata a doppio effetto VCR1 10 - D/AF Double-acting overcentre valve with shuttle valve VCR1 10 - D/AF	•	/
M103	Valvola bilanciata di blocco e controllo discesa VCD2 10 - S/AF Overcentre Valve with VCD2 10 - S/AF	•	/

• Disponibile - Available / Non Disponibile - Not Available

#### 9 - CARATTERISTICA VALVOLA / VALVES FEATURE

		VALVOLA / VALVE			
		XXXX	M101	M102	M103
000	Caratteristica non necessaria Feature not necessary	•	/	/	/
023	Non Tarata (Campo Taratura 100+350 bar) - Senso di rotazione DX Not Set 100+350 bar [1450 to 5075 psi] - Direction of rotation CW	/	/	/	•
024	Non Tarata (Campo Taratura 100+350 bar) - Senso di rotazione SX Not Set 100+350 bar [1450 to 5075 psi] - Direction of rotation CCW	/	/	/	•
026	Non Tarata (Campo Taratura 30+210 bar) - Senso di rotazione DX Not Set 30+210 bar [435 to 3045 psi] - Direction of rotation CW	/	/	/	•
027	Non Tarata (Campo Taratura 30+210 bar) - Senso di rotazione SX Not Set 30+210 bar [435 to 3045 psi] - Direction of rotation CCW	/	/	/	•
020	Non Tarata (Campo Taratura 100+200 bar) Not Set 100+200 bar [1450 to 2900 psi]	/	•	/	/
025	Non Tarata (Campo Taratura 210+300 bar) Not Set 210+300 bar [3045 to 4350 psi]	/	•	/	/
700	Rapporto di Pilotaggio 7:1 Pilot Ratio 7:1	/	/	•	/
100	Rapporto di Pilotaggio 10:1 Pilot Ratio 10:1	/	/	•	/

• Disponibile - Available / Non Disponibile - Not Available

#### 10 - VALVOLA DI LAVAGGIO / FLUSHING VALVE

XX	Non Richieste Not Required
06	Valvola di lavaggio VSC/F - 6 l/min VSC/F Flushing valve - 6 l/min [1.58 U.S. gpm]
09	Valvola di lavaggio VSC/F - 10.5 l/min VSC/F Flushing valve - 10.5 l/min [2.77 U.S. gpm]
15	Valvola di lavaggio VSC/F - 15 l/min VSC/F Flushing valve - 15 l/min [3.96 U.S. gpm]
21	Valvola di lavaggio VSC/F - 20 l/min VSC/F Flushing valve - 20 l/min [5.28 U.S. gpm]

E' possibile combinare le valvole di lavaggio solo con la valvola VAF 10 - D  
It is possible to combine the flushing valves only with VAF 10 - D valve.

1	2	3	4	5	6	7	8	9	10	11	12	13

### 11 - OPZIONE / OPTION

XX	Nessun Opzione None
----	------------------------

### 12 - CARATTERISTICA VERSIONE / VERSION FEATURE

		VERSIONE/ VERSION		
		S	C	F
XXX	Versione base Standard version	STANDARD		
HPS	Guarnizione alta pressione High Pressure Seal	•	/	/
HD0	Heavy duty (disponibile solo con attacchi M10, alberi CL400-CN400-SC380 e senza valvole interne di drenaggio) Heavy duty (available only with M10 Main ports, CL400-CN400-SC380 shats and without internal check valves)	•	/	/
DH0	Heavy duty (disponibile solo con attacchi M10, alberi CL400-CN400-SC380 e senza valvole interne di drenaggio) + Guarnizione alta pressione Heavy duty (available only with M10 Main ports, CL400-CN400-SC380 shats and without internal check valves) + High Pressure Seal	•	/	/
TC7	Tachimetro con predisposizione per sensore (disponibile solo con flangia C4 attacchi M10 e flangia 4C attacchi S10) Tachometer with sensor arrangement (available only with C4 flange and M10 main ports and C4 flange and M10 main ports)	•	/	/
TC8	Tachimetro con sensore con cavo lunghezza 2 metri (disponibile solo con flangia C4 attacchi M10 e flangia 4C attacchi S10) Tachometer with sensor with 2 metres cable (available only with C4 flange and M10 main ports and C4 flange and M10 main ports)	•	/	/

• Disponibile - Available / Non Disponibile - Not Available

### 13 - VERNICIATURA / PAINTING

XX	Non verniciato Not painted
01	Verniciato Nero RAL 9005 Black Painted RAL 9005

# DIMENSIONI E PESI DIMENSIONS AND WEIGHT

## VERSIONE BASE - "S" "S" - STANDARD VERSION

Tipo "C4" - ISO 4 FORI Ø125mm  
Type "C4" - ISO 4 BOLTS Ø125mm (Ø4.921 in)

Tipo "4C" - SAE C 4 FORI  
Type "4C" - SAE C 4 BOLTS

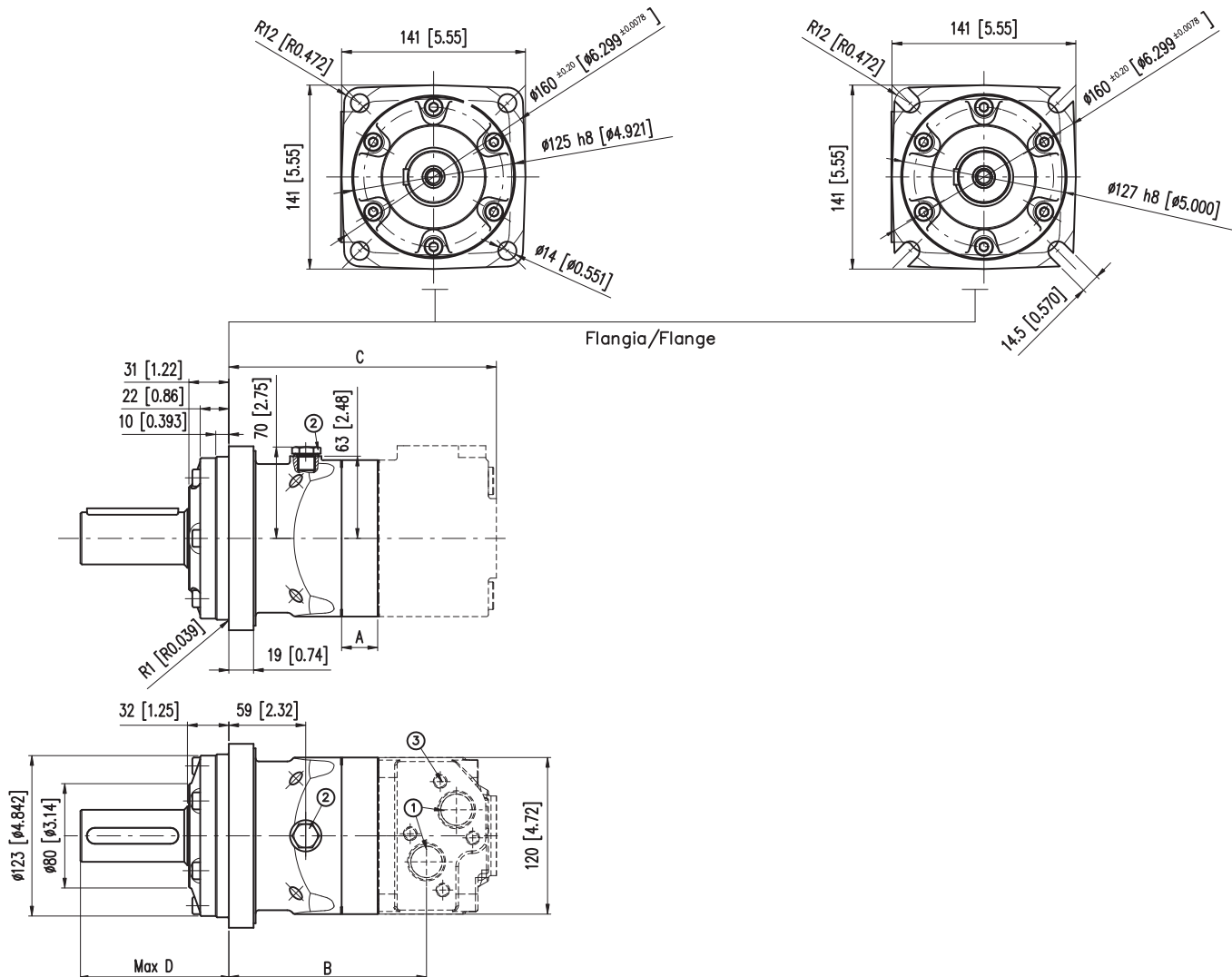

- 1) Fori di alimentazione  
Main ports
- 2) Drenaggio motore 1/4 G (BSPP) prof. filetto 12 mm (Versione con flangia C4)  
1/4 G (BSPP) drain port thread depth [0.472 in] (With C4 flange version)  
Drenaggio motore 9/16 - 18 UNF prof. filetto 13 mm (Versione con flangia 4C)  
9/16 - 18 UNF drain port thread depth [0.511 in] (With 4C flange version)
- 3) Fori M10 (Versione con attacchi M10)  
M10 hole (With M10 main ports version)

Cil. (cm <sup>3</sup> /giro) Displ. [in <sup>3</sup> /rev]	160 [9.7]	200 [12.2]	250 [15.2]	315 [19.2]	400 [24.4]	500 [30.5]
A mm A [in]	17 [0.67]	22 [0.87]	28.2 [1.11]	37.5 [1.48]	48 [1.89]	62 [2.44]
B mm B [in]	140 [5.51]	145 [5.71]	153.2 [6.03]	160.5 [6.32]	171 [6.73]	185 [7.28]
C mm C [in]	193.6 [7.62]	198.6 [7.82]	206.8 [8.14]	214.1 [8.43]	224.6 [8.84]	238.6 [9.39]
Pesi kg Weight [lb]	20 [44]	20.5 [45.1]	21 [46.2]	22 [48.4]	23 [50.6]	24 [52.8]
ALBERO SHAFT	CL400	C3800		CN400		SC380
D (mm) D [in]	113.8 [4.48]	91.2 [3.59]		113.6 [4.47]		113.7 [4.47]

# DIMENSIONI E PESI DIMENSIONS AND WEIGHT

## VERSIONE BASE - "C" "C" - STANDARD VERSION

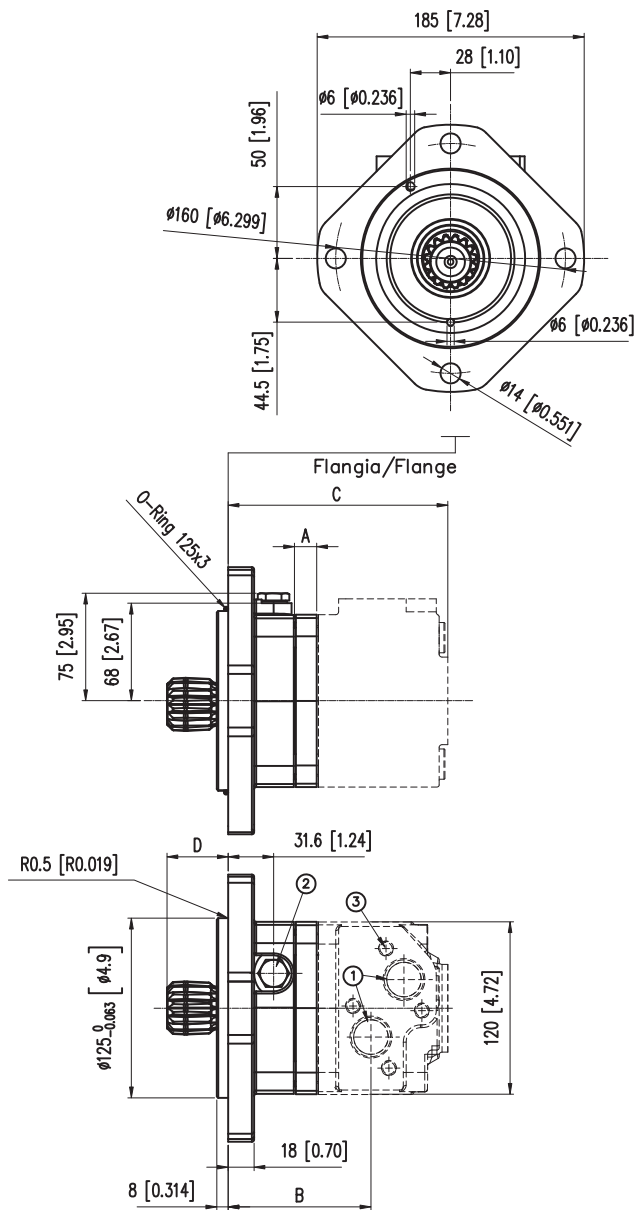

Tipo "C4-CS" - ISO 4 FORI Ø125mm  
Type "C4-CS" - ISO 4 BOLTS Ø125mm (Ø4.921 in)

- 1) Fori di alimentazione  
Main ports
- 2) Drenaggio motore 1/4 G (BSPP) prof. filetto 14 mm (Versione con flangia C4)  
1/4 G (BSPP) drain port thread depth [0.551 in] (With C4 flange version)  
Drenaggio motore 9/16 - 18 UNF prof. filetto 14 mm (Versione con flangia CS)  
9/16 - 18 UNF drain port thread depth [0.551 in] (With CS flange version)
- 3) Fori M10 (Versione con attacchi M10)  
M10 hole (With M10 main ports version)

Cil. (cm <sup>3</sup> /giro) Displ. [in <sup>3</sup> /rev]	160 [9.7]	200 [12.2]	250 [15.2]	315 [19.2]	400 [24.4]	500 [30.5]
A mm A [in]	17 [0.67]	22 [0.87]	28.2 [1.11]	37.5 [1.48]	48 [1.89]	62 [2.44]
B mm B [in]	99.5 [3.92]	104.5 [4.11]	110.7 [4.36]	120 [4.72]	130.5 [5.14]	144.5 [5.69]
C mm C [in]	154 [6.06]	159 [6.26]	165.2 [6.50]	174.5 [6.87]	185 [7.28]	199 [7.83]
D mm D [in]	45 [1.77]	45 [1.77]	45 [1.77]	45 [1.77]	45 [1.77]	45 [1.77]
Pesi kg Weight [lb]	14.5 [31.9]	14.75 [32.5]	15 [33]	15.3 [33.8]	15.78 [34.8]	16.3 [36]

# DIMENSIONI E PESI DIMENSIONS AND WEIGHT

## VERSIONE FRENO - "F" "F" - BRAKE VERSION

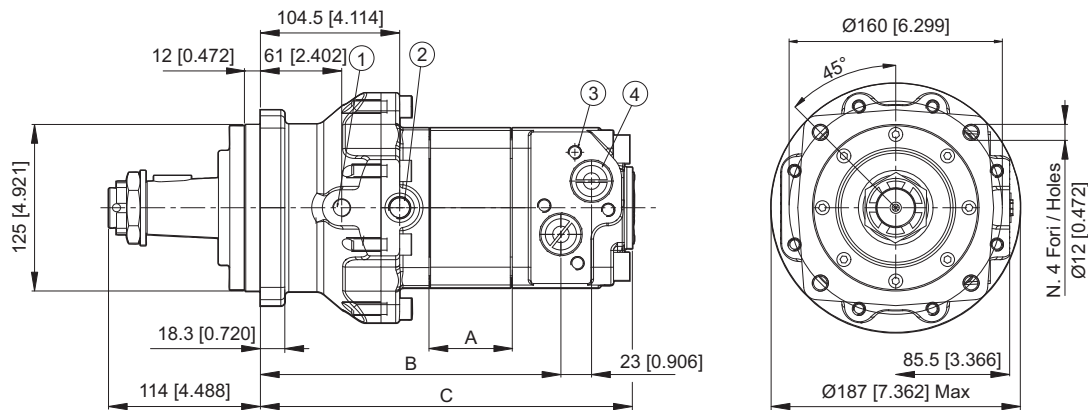

- 1) Attacco freno G 1/4 - profondità 12 mm  
Brake release port G 1/4 - 12 mm [0.47] deep
- 2) Drenaggio G 3/8 - profondità 14 mm  
Drain connection G 3/8 - 14 mm [0.55] deep
- 3) M10 - profondità 10 mm  
M10 - 10 mm [0.39] deep
- 4) G 3/4 - profondità 17mm  
G 3/4 - 17 mm [0.67] deep

Cil. (cm <sup>3</sup> /giro) Displ. [in <sup>3</sup> /rev]	160 [9.7]	200 [12.2]	250 [15.2]	315 [19.2]	400 [24.4]	500 [30.5]
A mm A [in]	17 [0.67]	22 [0.87]	28.2 [1.11]	37.5 [1.48]	48 [1.89]	62 [2.44]
B mm B [in]	180 [7.09]	185 [7.28]	191.2 [7.53]	200.5 [7.89]	211 [8.31]	225 [8.86]
C mm C [in]	233.6 [9.20]	225.6 [8.88]	244.8 [9.64]	254.1 [10]	264.6 [10.42]	278.6 [10.97]
Pesi kg Weight [lb]	25,5 [56,22]	25,8 [56,88]	26,1 [57,54]	26,3 [57,98]	27,3 [60,19]	28,2 [62,17]
<b>ALBERO SHAFT</b>	<b>CL400</b>		<b>CN400</b>		<b>SC380</b>	
D (mm) D [in]	113.8 [4.48]		113.6 [4.47]		113.7 [4.47]	

# DIMENSIONI ACCOPPIAMENTO DIMENSIONS OF COUPLING COMPONENTS

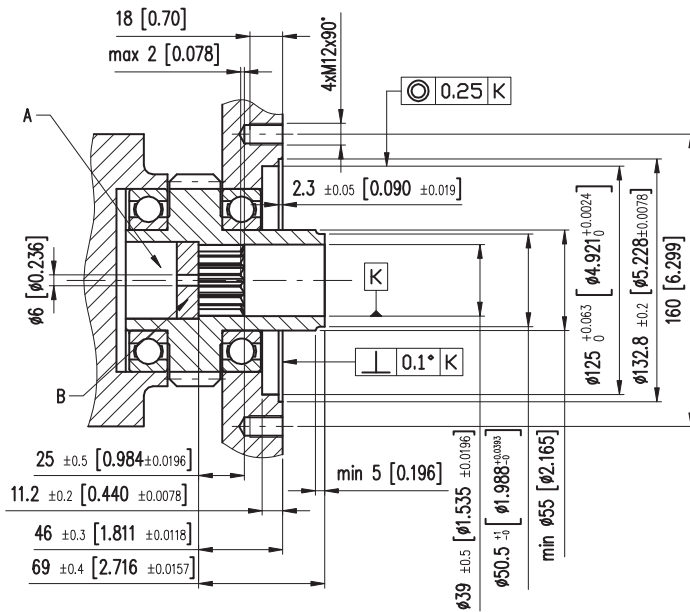

A: Foro di ricolazione olio/Oil circulation hole  
B: Piastra di riscontro indurita/Hardened stop plate

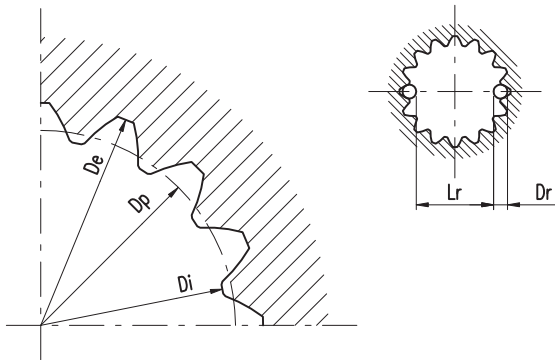

Profilo scanalato / Internal involute spline  
Standard ANS B92.1 - 1970 classe 5  
(correzione / corrected  $m \cdot x = 1$ )

Passo diametrale Diametral Pich		12/24
Numero di denti Number of theeth	Z	16
Diametro primitivo Pich diameter	Dp	33.866
Angolo di pressione Pressure angle		30°
Modulo Module	m	2.1166
Diametro interno Minor diameter	Di	32.15 <sup>+0.25</sup> <sub>0</sub>
Diametro esterno Major diameter	De	38.4 <sup>+0.25</sup> <sub>0</sub>
Misura massima tra i rullini* Max measurement between pins*	Lr	26.9 <sup>+0.15</sup> <sub>0</sub>
Diametro rullini Pins diameter	Dr	4.834 h5

## Materiale:

Acciaio NiCr con trattamento termico di C.T.R. o durezza di 58 HRc.

## Material:

NiCr steel with case hardening, induction hardening and tempering treatment or with hardness of 58 HRc.

## Drenaggio:

La linea di drenaggio deve essere collegata quando la pressione sullo scarico del motore è superiore alla pressione ammessa dal componente accoppiato al motore. Il drenaggio può essere collegato in due punti:

- 1) Alla bocca di drenaggio del motore.
- 2) Alla bocca di drenaggio del componente accoppiato.

\* Dimensioni definitive dopo il trattamento

\* Finished dimensions (when hardened)

## Drain line:

A drain line must be used when the return line pressure exceed the permissible pressure in the attached component. The drain line can be connected at two different points:

- 1) At the motor drain connection.
- 2) At the drain connection of the attached component.

**ALBERO CILINDRICO CL400**  
**C40 PARALLEL KEYED SHAFT**

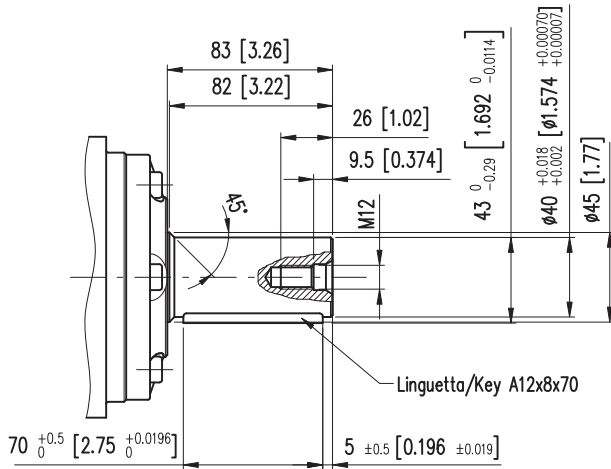

Coppia Massima 1220 Nm  
Max. admissible Torque Cont. 1220 Nm [899.14 lbf-ft]

**ALBERO SCANALATO SC380**  
**SC380 SPLINED SHAFT**

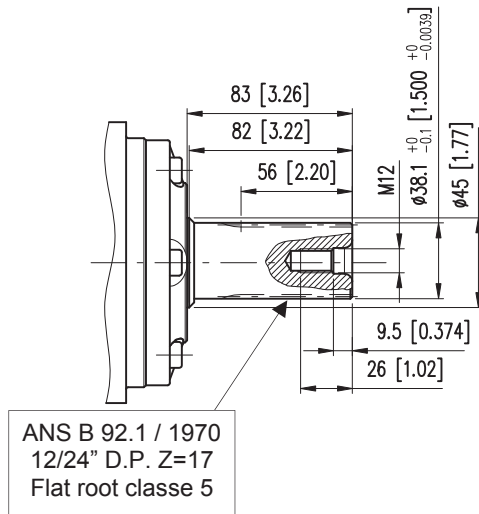

Coppia Massima 1220 Nm  
Max. admissible Torque Cont. 1220 Nm [899.14 lbf-ft]

**ALBERO CILINDRICO C380**  
**CL380 PARALLEL KEYED SHAFT**

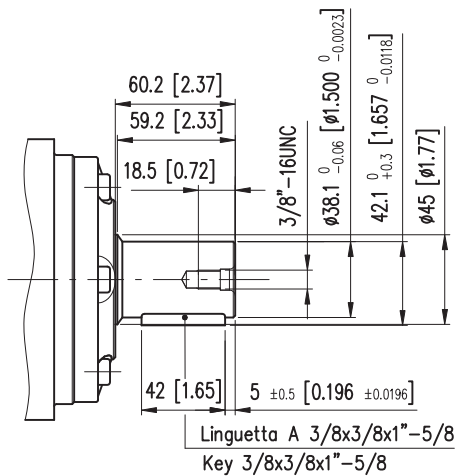

Coppia Massima 1220 Nm  
Max. admissible Torque Cont. 1220 Nm [899.14 lbf-ft]

**ALBERO CONICO CN400**  
**CN400 TAPERED SHAFT**

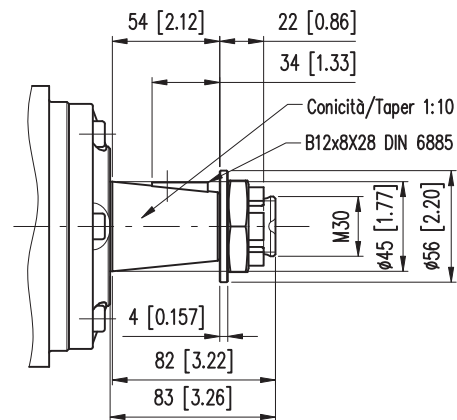

Coppia Massima 1220 Nm  
Max. admissible Torque Cont. 1220 Nm [899.14 lbf-ft]



# DIMENSIONI ATTACCHI E SENSO DI ROTAZIONE

## MAIN PORTS DIMENSIONS AND DIRECTION OF ROTATION

### ATTACCHI TIPO M10

#### MAIN PORTS TYPE M10

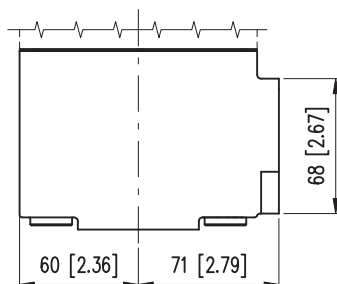
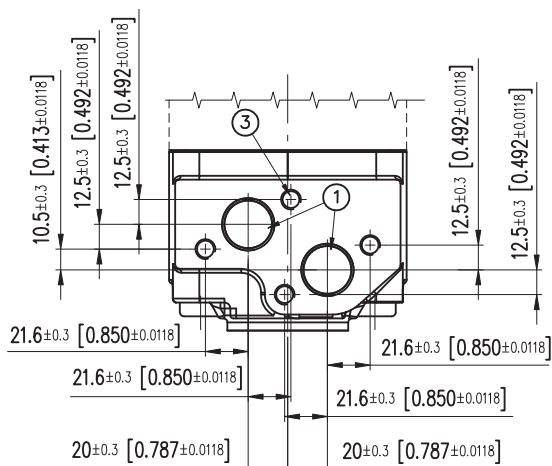

- 1) N.2 Fori di alimentazione 3/4 G (BSPP) prof. filetto 17 mm  
N.2 3/4 G (BSPP) main ports thread depth [0.66 in]
- 3) N.4 Fori M10 prof. filetto 12 mm  
N.4 M10 hole thread depth [0.472 in]

**Versione S**  
S Version

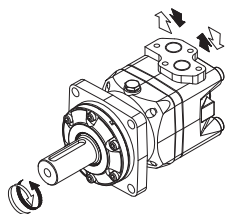

**Versione C**  
C Version

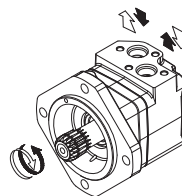

### ATTACCHI TIPO S10

#### MAIN PORTS TYPE S10

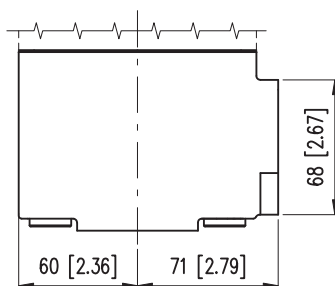
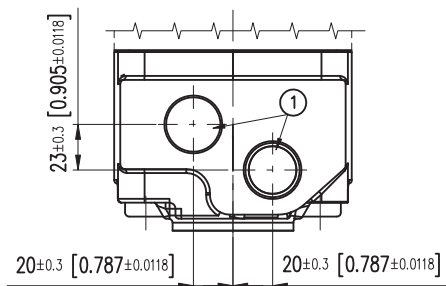

- 1) N.2 Fori di alimentazione 1 1/16 - 12 UN prof. filetto 20 mm  
N.2 1 1/16 - 12 UN main ports thread depth [0.78 in]

**Versione S**  
S Version

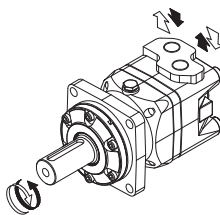

**Versione C**  
C Version

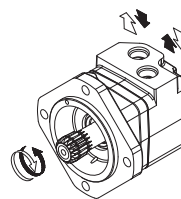

### COPERCHIO SPECIALE PER VALVOLA DI LAVAGGIO SPECIAL COVER FOR FLUSHING VALVE

Per il montaggio diretto della valvola di lavaggio sui motori è necessario utilizzare un coperchio speciale.

Questo è possibile solo con gli attacchi "M10-S10".

Se si vuole predisporre il motore con valvola di lavaggio è necessario specificare in fase d'ordine il tipo di valvola 06-09-15-21 (vedere il punto 10 del codice di ordinazione)

The mount the flushing valve on motors, it is necessary to use a special cover.

This is only possible with the "M10-S10" main ports.

If it is necessary to assembly the flushing valve on motors, to specify in the purchase order the valves type 06-09-15-21 (See position 10 of ordering code)

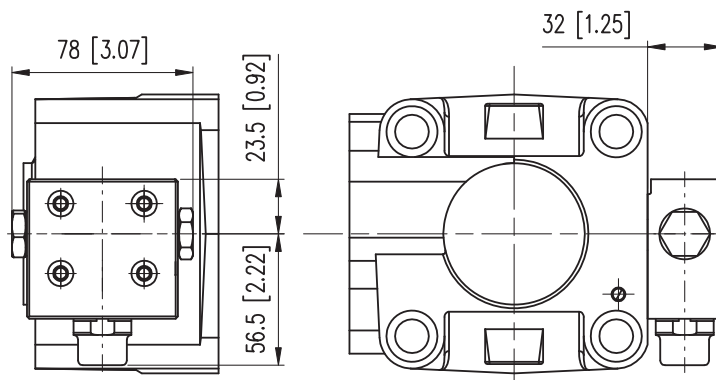

Per maggiori informazioni sulla valvola di lavaggio, consultare la sezione Valvole ed Accessori o il Bollettino Informativo 05-0082-A04  
For more informations on the Flushing valve, see the Valves and Accessories section or Service Bulletin - 05-0082-A04

### VERSIONE HEAVY DUTY HEAVY DUTY VERSION

Rispetto alla versione standard, la versione heavy duty presenta le seguenti caratteristiche:

- 1) Le viti del coperchio porta tenuta sono montate con frena filetti per evitare lo sviamento dovuto alle vibrazioni.
- 2) Coperchio porta tenuta in materiale rinforzato.
- 3) Le valvole di drenaggio non sono presenti perché la linea del drenaggio deve essere sempre usata in applicazioni dove i parametri di esercizio sono severi

Compared to the standard version, the heavy duty has the following differences:

- 1) The screw in the seal cover are fitted with thread locker to prevent the screws being loosened by vibration.
- 2) Seal cover with reinforced material.
- 3) The check valves have been omitted because a drain line is always used in applications where operating conditions are severe.

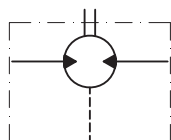
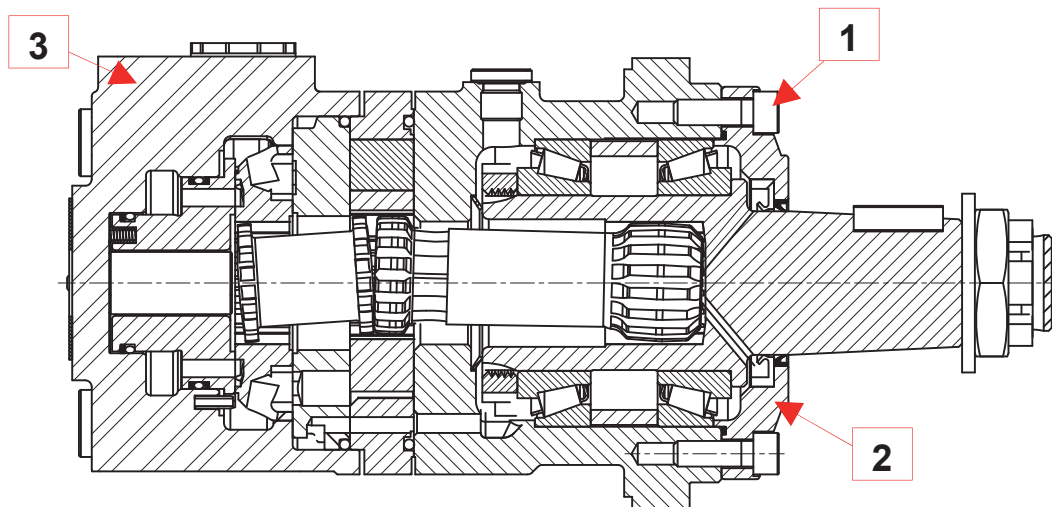

**Nota:** La linea del drenaggio deve sempre essere usata perché il motore non ha le valvole interne di drenaggio  
**Note:** A drain line must always be used because the motors have no built-in check valves

## CARATTERISTICHE FRENO BRAKE FEATURE

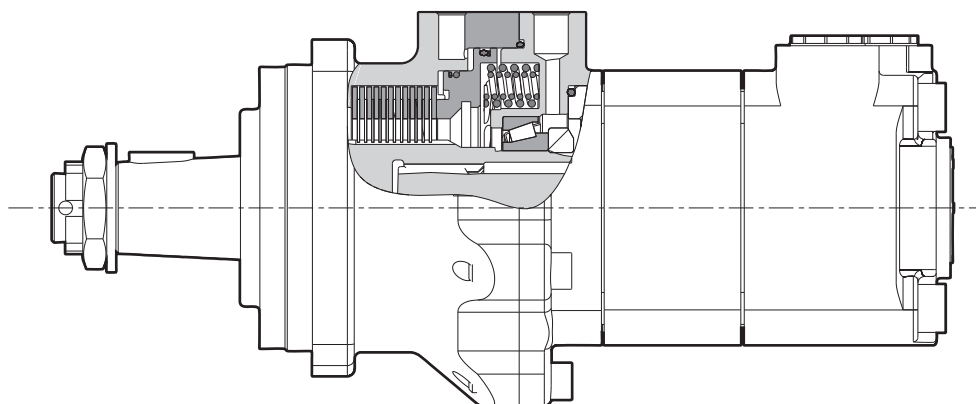

Minima coppia statica di frenatura Minimum brake static torque	142 daNm [1047 lb.ft]
Pressione di apertura minima Starting release pressure	30 bar [435 psi]
Pressione freno libero Full release pressure	35 bar [508 psi]
Pressione massima linea scarico Max pressure drain line	5 bar [73 psi]
Pressione massima sul freno Max pressure in brake line	280 bar [4060 psi]

I freni integrati dei motori-freno versione F sono del tipo multidisco a sblocco sotto pressione per uso in condizioni statiche. Quando l'olio proveniente dalla pompa non è in pressione, una serie di molle mantiene premuti i dischi gli uni contro gli altri; pertanto, l'albero del motore non potrà ruotare se non trascinato da una coppia che ecceda di molto la massima coppia di frenatura statica del freno. Inviando olio al motore, una valvola di commutazione (da inserire nell'impianto) devia al freno parte del flusso, vincendo così la resistenza delle molle che, sbloccando il freno, consentono la partenza del motore. I motori ruota necessitano di alcune attenzioni per quanto riguarda la progettazione della macchina da azionare. Gli aspetti più importanti da considerare sono:

- 1) Le conicità di mozzo ed albero motore devono combaciare perfettamente, in modo da evitare sovraccarichi sulla chiavetta, che potrebbero verificarsi qualora la rondella dell'albero andasse in appoggio sulla fine della parte conica dell'albero.
- 2) In caso di urti all'albero (come nel caso di macchine mobili che traslano su terreno sconnesso) si dovrà considerare un adeguato fattore di servizio.

The brakes built into F version motors are multidisc pressure released ones for static operation. With no pressure from the pump to the motor, a set of springs will push the discs one against the other, hence the motor shaft will not be allowed to rotate unless the shaft itself is driven with a torque widely exceeding the max. static torque of the brake. By sending pressure to the motor a shuttle valve (to be included in the system) will send pressure to the brake, overcome the resistance of the springs and release the brake hence allowing the start of the motor. Wheel motors require some care in the engineering of the machine. The major aspects to consider are:

- 1) Hub and motor shaft tapers must be perfectly matching, in order to avoid excessive key stress, which can occur in case of bottoming of shaft tip washer and nut at the end of the thread.
- 2) A proper service factor should be considered in case of shocks to the shaft (eg. With the machine travelling on very uneven soil).

stop has been reached.

**TACHIMETRO  
TACHOMETER**

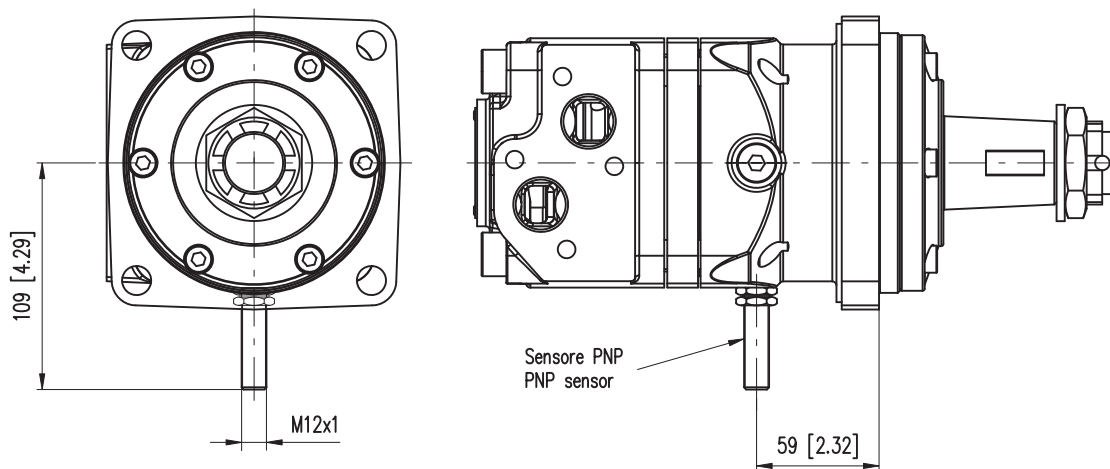

*Segnale in uscita*  
Output signal

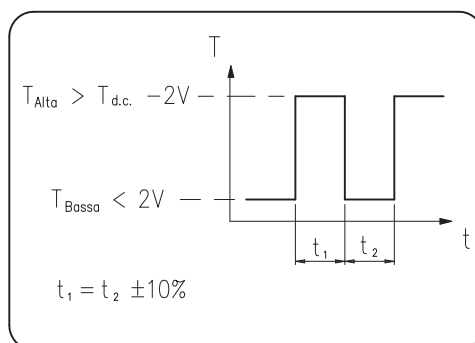

Numero d'impulsi per giro = 42  
Principio di funzionamento induttivo  
Funzione di uscita PNP  
Tensione nominale 10-65 V d.c.  
Caricabilità massima 300 mA  
Frequenza massima 1200 Hz  
Campo di temperatura -25C +85C  
Grado di protezione IP 67

Number of pulses per revolution = 42  
Inductive principle  
Output current PNP  
Voltage 10-65 V d.c.  
Max load 300 mA  
Max frequency 1200 Hz  
Temperature range -25C +85C  
Enclosure IP 67

## CARICHI AMMESSI SULL'ALBERO SHAFT LOAD CAPACITY

Il diagramma dei carichi è valido per una vita dei cuscinetti  $L_{10h}$  di 3000 ore alla velocità di 200 giri/min quando viene utilizzato olio a base minerale minerale con un adeguato contenuto di additivi anti usura. La vita dei cuscinetti è stata calcolata con un grado di affidabilità del 90%.

La curva "A" fornisce il carico radiale limite sopportato dai cuscinetti in condizioni di carico statico massimo.

Loads diagram is for a bearings life  $L_{10h}$  of 3000 hours at 200 rpm when mineral base hydraulic oil with a sufficient content of anti-wear additives is used. Bearing life calculation refers to a 90% degree of reliability.

Curve "A" shows the maximum radial load that can be taken by the bearings under maximum static load duty.

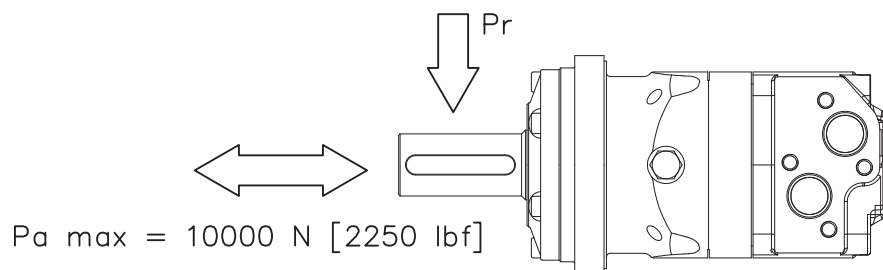
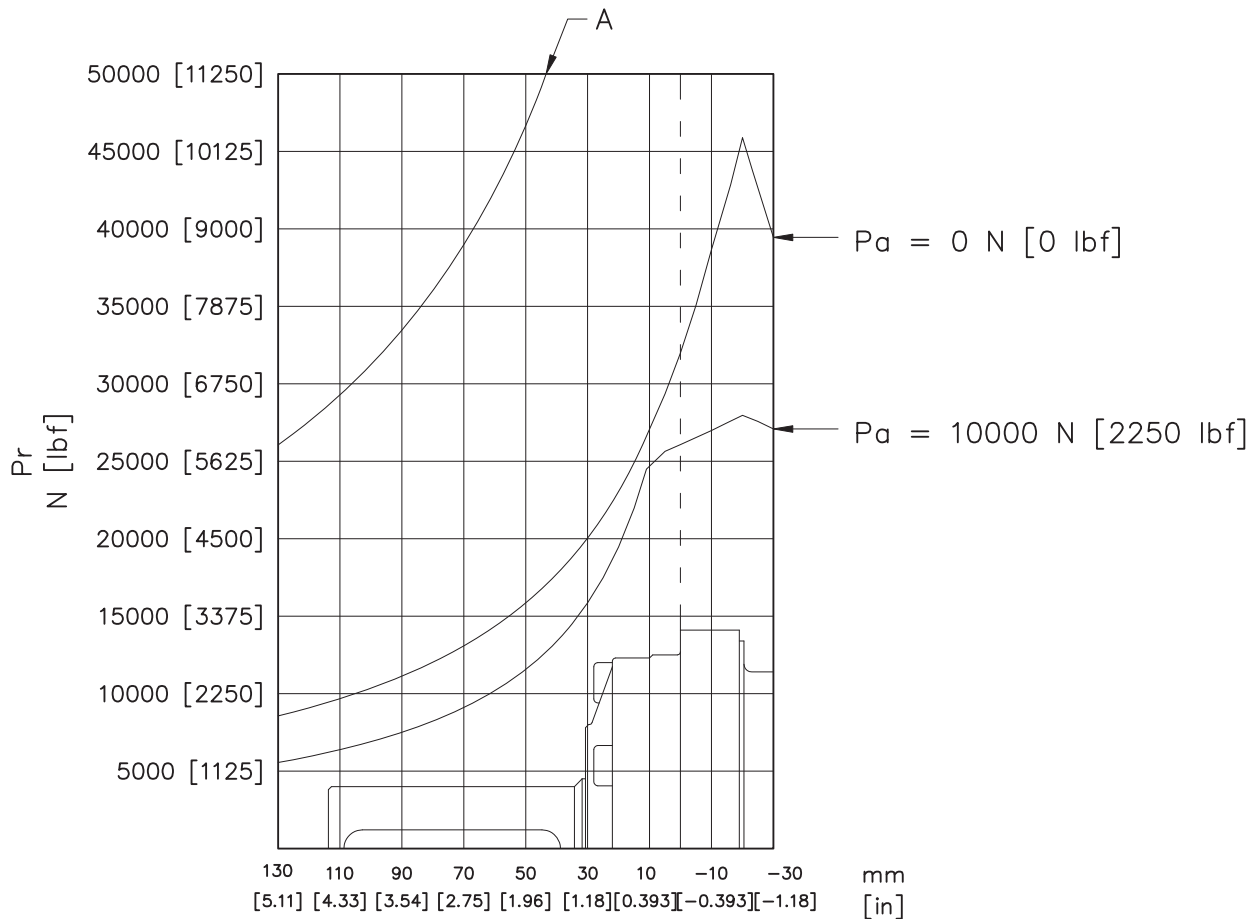

# HT 160

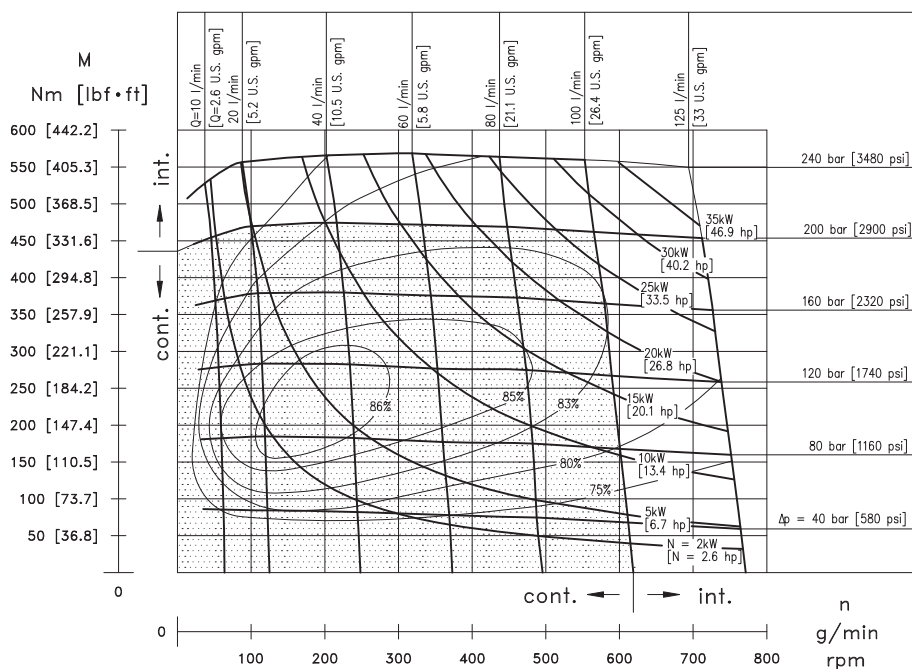

*Pressioni e portate superiori a quelle ammesse in regime continuo non devono essere applicate contemporaneamente.*

Exceeding continuous pressure values or exceeding flow values indicated, must not occur simultaneously.

**Nota:** Il diagramma è stato ottenuto con prove eseguite su un numero significativo di motori, utilizzando un olio avente una viscosità cinematica di 37 cSt alla temperatura di 45 C°.

**Note:** Diagram according to tests done with a relevant number of motors and using hydraulic oil with kinematic viscosity of 37 cSt at 45 C° temperature.

# HT 200

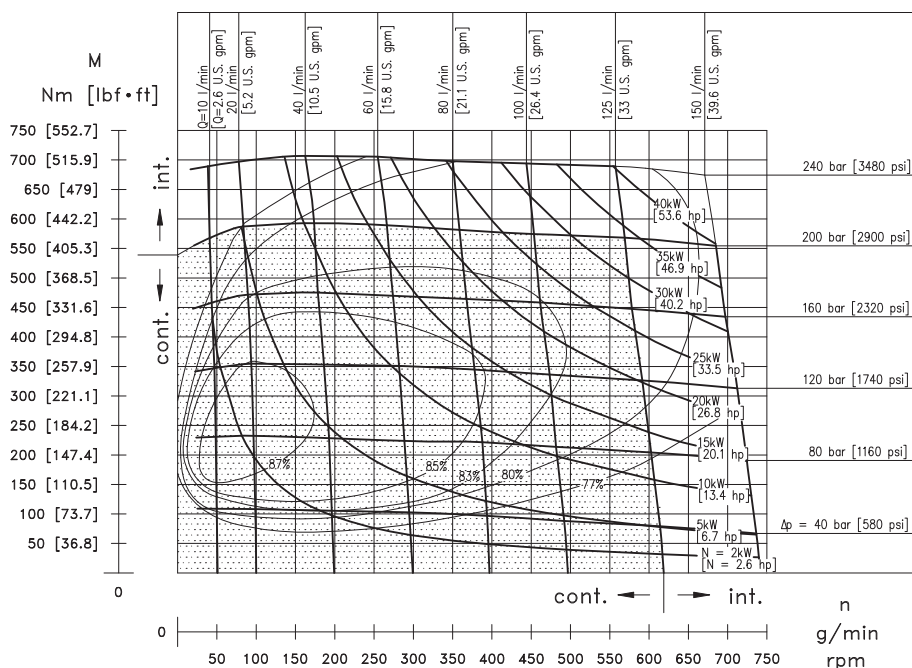

*Pressioni e portate superiori a quelle ammesse in regime continuo non devono essere applicate contemporaneamente.*

Exceeding continuous pressure values or exceeding flow values indicated, must not occur simultaneously.

**Nota:** Il diagramma è stato ottenuto con prove eseguite su un numero significativo di motori, utilizzando un olio avente una viscosità cinematica di 37 cSt alla temperatura di 45 C°.

**Note:** Diagram according to tests done with a relevant number of motors and using hydraulic oil with kinematic viscosity of 37 cSt at 45 C° temperature.

# HT 250

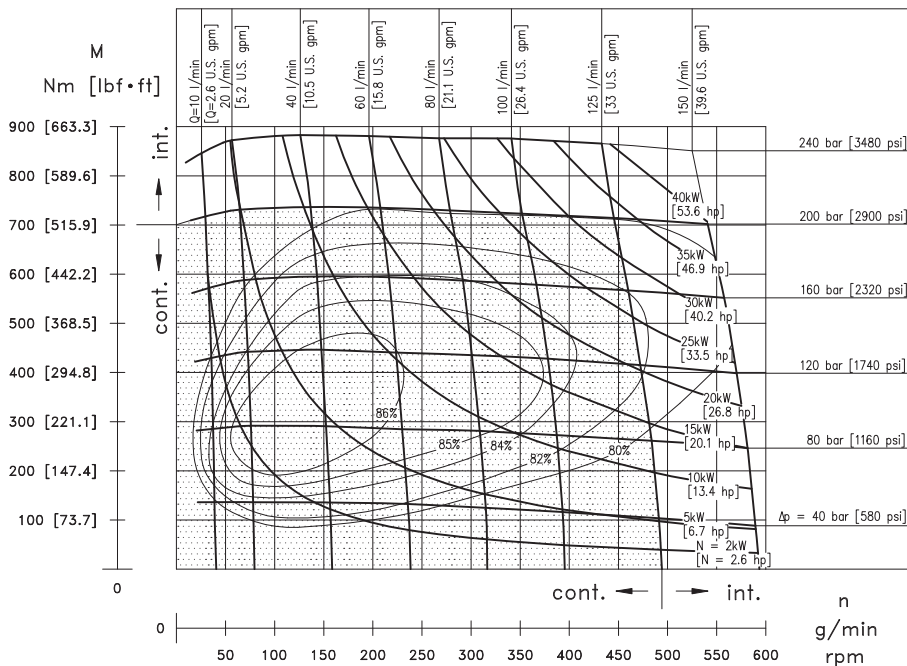

*Pressioni e portate superiori a quelle ammesse in regime continuo non devono essere applicate contemporaneamente.*

Exceeding continuous pressure values or exceeding flow values indicated, must not occur simultaneously.

**Nota:** Il diagramma è stato ottenuto con prove eseguite su un numero significativo di motori, utilizzando un olio avente una viscosità cinematica di 37 cSt alla temperatura di 45 C°.

**Note:** Diagram according to tests done with a relevant number of motors and using hydraulic oil with kinematic viscosity of 37 cSt at 45 C° temperature.

# HT 315

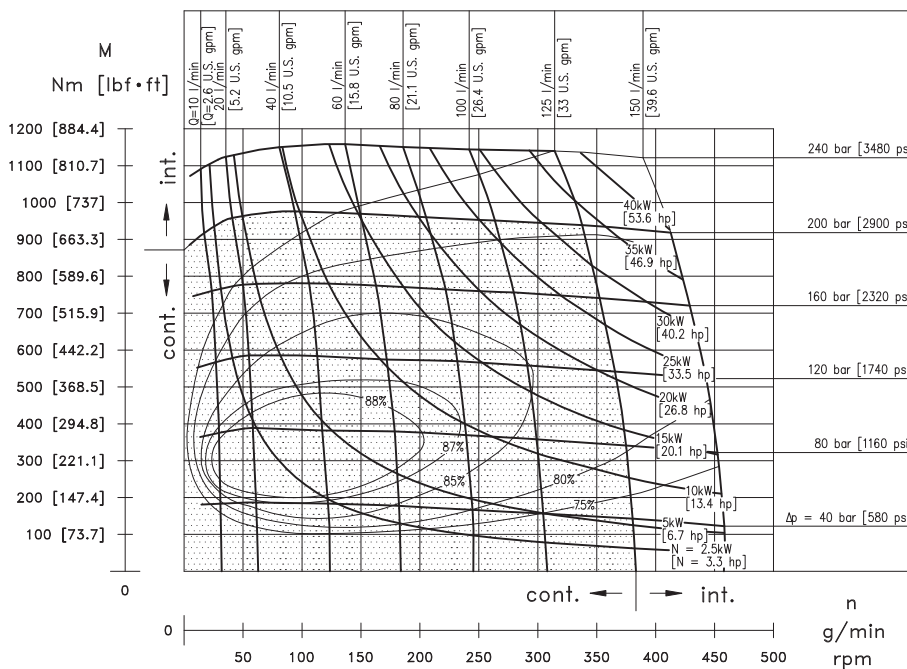

*Pressioni e portate superiori a quelle ammesse in regime continuo non devono essere applicate contemporaneamente.*

Exceeding continuous pressure values or exceeding flow values indicated, must not occur simultaneously.

**Nota:** Il diagramma è stato ottenuto con prove eseguite su un numero significativo di motori, utilizzando un olio avente una viscosità cinematica di 37 cSt alla temperatura di 45 C°.

**Note:** Diagram according to tests done with a relevant number of motors and using hydraulic oil with kinematic viscosity of 37 cSt at 45 C° temperature.



# HT 400

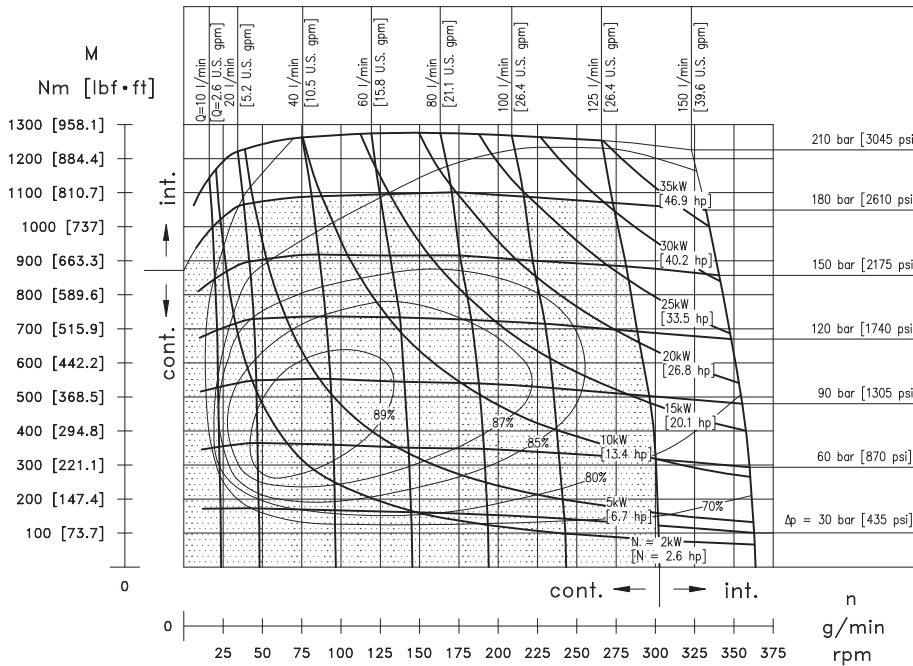

*Pressioni e portate superiori a quelle ammesse in regime continuo non devono essere applicate contemporaneamente.*

Exceeding continuous pressure values or exceeding flow values indicated, must not occur simultaneously.

**Nota:** Il diagramma è stato ottenuto con prove eseguite su un numero significativo di motori, utilizzando un olio avente una viscosità cinematica di 37 cSt alla temperatura di 45 C°.

**Note:** Diagram according to tests done with a relevant number of motors and using hydraulic oil with kinematic viscosity of 37 cSt at 45 C° temperature.

# HT 500

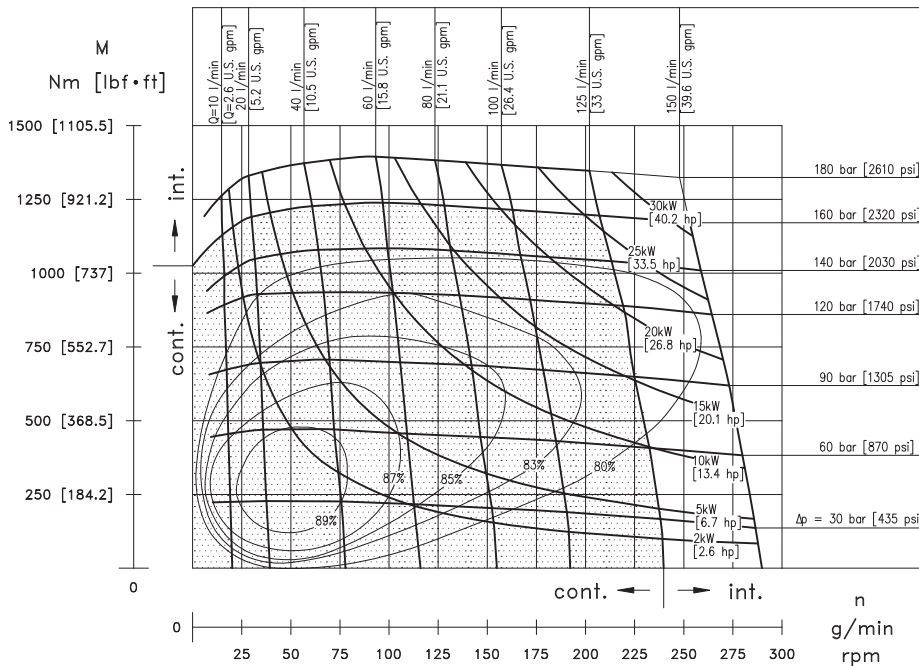

*Pressioni e portate superiori a quelle ammesse in regime continuo non devono essere applicate contemporaneamente.*

Exceeding continuous pressure values or exceeding flow values indicated, must not occur simultaneously.

**Nota:** Il diagramma è stato ottenuto con prove eseguite su un numero significativo di motori, utilizzando un olio avente una viscosità cinematica di 37 cSt alla temperatura di 45 C°.

**Note:** Diagram according to tests done with a relevant number of motors and using hydraulic oil with kinematic viscosity of 37 cSt at 45 C° temperature.





**BREVINI<sup>®</sup>**

*Motion Systems*

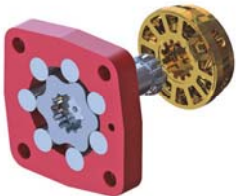

**BRZ**

***MOTORI ORBITALI***

**ORBITAL MOTORS**



### MOTORI CORTI PER RIDUTTORE

**BRZ** - Motori idraulici con organo motore tipo roller e distribuzione radiale. Disponibili nelle cilindrata da 50 a 400 cm<sup>3</sup>/giro per potenze sino a 13 kW. Sono disponibili valvole flangiabili per il controllo della traslazione e attacco per lo sblocco freno.

- Versioni:
  - **BRZL**: Motore con bocche filettate.
  - **BRZV**: Motore predisposto per l'utilizzo delle valvole opzionali.
- Valvole opzionali ed accessori:
  - **VCT11-SF**: Valvola controllo traslazione standard.
  - **VCT11-AF**: Valvola controllo traslazione con selettore apertura freno.
  - **CMZ**: Collettore modulare.



### SHORT MOTOR FOR GEAR BOXES

**BRZ** - Orbital motor with roller design and spool valve distributor. Motion control valve and disengagement brake port as optional. Available with displacement from 50 up to 400 cm<sup>3</sup>/giro [from 3.05 up to 24.4 in<sup>3</sup>/rev and power up to 13 kW [17.4 hp].

- Versions:
  - **BRZL**: Threaded ports motor.
  - **BRZV**: Valves version motor.
- Optional valves and accessories:
  - **VCT11-SF**: Standard motion control valve.
  - **VCT11-AF**: Motion control valve with disengagement brake port.
  - **CMZ**: Flangeable manifold.

## CODICE DI ORDINAZIONE MOTORE MOTOR ORDERING CODE

Serie Series		Cilindrata Displacement		Albero Shaft		Opzioni Options	
<b>BRZV</b>		<b>50</b>		<b>S14</b>		<b>HPS</b>	
CODICE CODE	Serie Series	CODICE CODE	Cilindrata Displacement	CODICE CODE	Albero Shaft	CODICE CODE	Opzioni Options
BRZV	Motore BRZV BRZV Motor	50	51.6 cm <sup>3</sup> /giro [3.14 in <sup>3</sup> /rev]	S14	Scanalato B 25x22 DIN 5482 B 25x22 DIN 5482 Splined	HPS	Guarnizione alta pressione Pressure high seal
BRZL	Motore BRZL (*) BRZL Motor (*)	65	64.9 cm <sup>3</sup> /giro [3.95 in <sup>3</sup> /rev]			TAC-U	Tachimetro + Guarnizione alta pressione Tachometer + Pressure high seal
		80	80.4 cm <sup>3</sup> /giro [4.9 in <sup>3</sup> /rev]				
		100	100 cm <sup>3</sup> /giro [6.1 in <sup>3</sup> /rev]				
		130	125.7 cm <sup>3</sup> /giro [7.66 in <sup>3</sup> /rev]				
		160	160 cm <sup>3</sup> /giro [9.76 in <sup>3</sup> /rev]				
		200	200 cm <sup>3</sup> /giro [12.2 in <sup>3</sup> /rev]				
		250	250 cm <sup>3</sup> /giro [15.2 in <sup>3</sup> /rev]				
		315	314.5 cm <sup>3</sup> /giro [19.1 in <sup>3</sup> /rev]				
		400	393 cm <sup>3</sup> /giro [23.9 in <sup>3</sup> /rev]				

\*SPECIALE A RICHIESTA - SPECIAL ON REQUEST

*In caso di caratteristiche non elencate, contattare Uff. Tecnico.*  
Please contact technical department for not listed features.

## CODICE DI ORDINAZIONE VALVOLE E COLLETTORI VALVES AND MANIFOLD ORDERING CODE

Solo motore BRZV - Da ordinare separatamente al motore  
Only BRZV motor - To be ordered separately to the motor.

Valvola Valve	
<b>VCT 11 AF</b>	
CODICE CODE	Valvola** Valve**
VCT 11 SF	VCT 11 SF
VCT11 AF	VCT11 AF
VCT 11 SF SAE	VCT 11 SF SAE
VCT11 AF SAE	VCT11 AF SAE
CMZ SF	CMZ SF
CMZ AF	CMZ AF

Motore Motor	Cilindrata Displacement cm <sup>3</sup> /rev [in <sup>3</sup> /rev]	Pressione max ingresso Max. input pressure bar [psi]	Pressione diff. max. Max. differential pressure bar [psi]	Coppia max. Max. torque Nm [lbf-ft]	Portata max. Max. flow l/min [U.S. gpm]	Velocità max. Max. speed giri/min [rpm]	Potenza max. Max. power kW [hp]
BRZ 50	51.6 [3.14]	Cont Int <sup>1)</sup> Peak <sup>2)</sup> 175 [2537] 200 [2900] 225 [3262]	Cont Int <sup>1)</sup> Peak <sup>2)</sup> 140 [2030] 175 [2540] 225 [3262]	Cont Int <sup>1)</sup> 103 [75.9] 126 [92.8]	Cont Int <sup>1)</sup> 40 [10.6] 50 [13.2]	Cont Int <sup>1)</sup> 775 969	Cont Int <sup>1)</sup> 6.8 [9.1] 8.4 [11.2]
BRZ 65	64.9 [3.95]	Cont Int <sup>1)</sup> Peak <sup>2)</sup> 175 [2537] 200 [2900] 225 [3262]	Cont Int <sup>1)</sup> Peak <sup>2)</sup> 150 [2175] 185 [2682] 225 [3262]	Cont Int <sup>1)</sup> 140 [103.1] 166 [122.3]	Cont Int <sup>1)</sup> 50 [13.2] 60 [15.9]	Cont Int <sup>1)</sup> 770 924	Cont Int <sup>1)</sup> 9.2 [12.3] 10.6 [14.2]
BRZ 80	80.4 [4.9]	Cont Int <sup>1)</sup> Peak <sup>2)</sup> 175 [2537] 200 [2900] 225 [3262]	Cont Int <sup>1)</sup> Peak <sup>2)</sup> 175 [2537] 200 [2900] 225 [3262]	Cont Int <sup>1)</sup> 197 [145.1] 218 [160.6]	Cont Int <sup>1)</sup> 60 [15.9] 75 [19.8]	Cont Int <sup>1)</sup> 746 933	Cont Int <sup>1)</sup> 13 [17.4] 15 [20.1]
BRZ 100	100 [6.1]	Cont Int <sup>1)</sup> Peak <sup>2)</sup> 175 [2537] 200 [2900] 225 [3262]	Cont Int <sup>1)</sup> Peak <sup>2)</sup> 175 [2537] 200 [2900] 225 [3262]	Cont Int <sup>1)</sup> 237 [174.6] 277 [204.1]	Cont Int <sup>1)</sup> 60 [15.9] 75 [19.8]	Cont Int <sup>1)</sup> 600 750	Cont Int <sup>1)</sup> 13 [17.4] 15 [20.1]
BRZ 130	125.7 [7.66]	Cont Int <sup>1)</sup> Peak <sup>2)</sup> 175 [2537] 200 [2900] 225 [3262]	Cont Int <sup>1)</sup> Peak <sup>2)</sup> 175 [2537] 200 [2900] 225 [3262]	Cont Int <sup>1)</sup> 300 [221.1] 340 [250.5]	Cont Int <sup>1)</sup> 60 [15.9] 75 [19.8]	Cont Int <sup>1)</sup> 477 597	Cont Int <sup>1)</sup> 12.5 [16.8] 14.5 [19.4]
BRZ 160	160 [9.76]	Cont Int <sup>1)</sup> Peak <sup>2)</sup> 175 [2537] 200 [2900] 225 [3262]	Cont Int <sup>1)</sup> Peak <sup>2)</sup> 140 [2030] 175 [2540] 225 [3262]	Cont Int <sup>1)</sup> 296 [218.1] 375 [276.3]	Cont Int <sup>1)</sup> 60 [15.9] 75 [19.8]	Cont Int <sup>1)</sup> 375 469	Cont Int <sup>1)</sup> 10 [13.4] 12.5 [16.8]
BRZ 200	200 [12.2]	Cont Int <sup>1)</sup> Peak <sup>2)</sup> 175 [2537] 200 [2900] 225 [3262]	Cont Int <sup>1)</sup> Peak <sup>2)</sup> 115 [1667] 140 [2030] 225 [3262]	Cont Int <sup>1)</sup> 297 [218.8] 380 [280]	Cont Int <sup>1)</sup> 60 [15.9] 75 [19.8]	Cont Int <sup>1)</sup> 300 375	Cont Int <sup>1)</sup> 8.5 [11] 10 [13.4]
BRZ 250	250 [15.2]	Cont Int <sup>1)</sup> Peak <sup>2)</sup> 175 [2537] 200 [2900] 225 [3262]	Cont Int <sup>1)</sup> Peak <sup>2)</sup> 90 [1305] 120 [1740] 225 [3262]	Cont Int <sup>1)</sup> 297 [218.8] 377 [277.8]	Cont Int <sup>1)</sup> 60 [15.9] 75 [19.8]	Cont Int <sup>1)</sup> 240 300	Cont Int <sup>1)</sup> 7.1 [9.5] 8.5 [11]
BRZ 315	314.5 [19.1]	Cont Int <sup>1)</sup> Peak <sup>2)</sup> 175 [2537] 200 [2900] 225 [3262]	Cont Int <sup>1)</sup> Peak <sup>2)</sup> 70 [1020] 100 [1450] 210 [3045]	Cont Int <sup>1)</sup> 300 [221.1] 420 [309.5]	Cont Int <sup>1)</sup> 60 [15.9] 75 [19.8]	Cont Int <sup>1)</sup> 191 238	Cont Int <sup>1)</sup> 5 [6.7] 6.6 [8.8]
BRZ 400	393 [23.9]	Cont Int <sup>1)</sup> Peak <sup>2)</sup> 175 [2537] 200 [2900] 225 [3262]	Cont Int <sup>1)</sup> Peak <sup>2)</sup> 55 [800] 85 [1230] 175 [2537]	Cont Int <sup>1)</sup> 292 [215.2] 425 [313.2]	Cont Int <sup>1)</sup> 60 [15.9] 75 [19.8]	Cont Int <sup>1)</sup> 153 191	Cont Int <sup>1)</sup> 4.1 [5.4] 6.1 [8.1]

Motore Motor	Max press. di scarico con drenaggio aperto Max back pressure with drain line bar [psi]	Pressione max avviamento a vuoto Max starting pressure in unloaded conditions bar [psi]	Coppia min di spunto Min starting torque Nm [lbf-ft]
BRZ 50	Cont Int <sup>1)</sup> Peak <sup>2)</sup> 175 [2538] 200 [2900] 225 [3263]	10 [145]	at Δp max at Δp max Cont Int <sup>1)</sup> 75[55.3] 95[70.0]
BRZ 65	Cont Int <sup>1)</sup> Peak <sup>2)</sup> 175 [2538] 200 [2900] 225 [3263]	10 [145]	at Δp max at Δp max Cont Int <sup>1)</sup> 120[88.4] 140[103.1]
BRZ 80	Cont Int <sup>1)</sup> Peak <sup>2)</sup> 175 [2538] 200 [2900] 225 [3263]	10 [145]	at Δp max at Δp max Cont Int <sup>1)</sup> 160[118] 180[133]
BRZ 100	Cont Int <sup>1)</sup> Peak <sup>2)</sup> 175 [2538] 200 [2900] 225 [3263]	10 [145]	at Δp max at Δp max Cont Int <sup>1)</sup> 200[147] 225[166]
BRZ 130	Cont Int <sup>1)</sup> Peak <sup>2)</sup> 175 [2538] 200 [2900] 225 [3263]	9 [131]	at Δp max at Δp max Cont Int <sup>1)</sup> 255[188] 290[214]
BRZ 160	Cont Int <sup>1)</sup> Peak <sup>2)</sup> 175 [2538] 200 [2900] 225 [3263]	7 [102]	at Δp max at Δp max Cont Int <sup>1)</sup> 250[184] 300[221]
BRZ 200	Cont Int <sup>1)</sup> Peak <sup>2)</sup> 175 [2538] 200 [2900] 225 [3263]	5 [72.5]	at Δp max at Δp max Cont Int <sup>1)</sup> 250[184] 320[236]
BRZ 250	Cont Int <sup>1)</sup> Peak <sup>2)</sup> 175 [2538] 200 [2900] 225 [3263]	5 [72.5]	at Δp max at Δp max Cont Int <sup>1)</sup> 250[184] 310[228]
BRZ 315	Cont Int <sup>1)</sup> Peak <sup>2)</sup> 175 [2538] 200 [2900] 225 [3263]	5 [72.5]	at Δp max at Δp max Cont Int <sup>1)</sup> 250[184] 300[221]
BRZ 400	Cont Int <sup>1)</sup> Peak <sup>2)</sup> 175 [2538] 200 [2900] 225 [3263]	5 [72.5]	at Δp max at Δp max Cont Int <sup>1)</sup> 250[184] 320[236]

\* Le condizioni intermittenti non devono durare più del 10% di ogni minuto. Intermittent duty must not exceed 10% each minute.

\*\* Le condizioni di picco non devono durare più del 1% di ogni minuto. Peak duty must not exceed 1% each minute.

Per le caratteristiche tecniche non elencate fare riferimento alla parte del catalogo relativa ai motori BR.

As regards not specified technical features, please refer to the section of the catalogue that concerns BR motors.

**SPECIALE A RICHIESTA - SPECIAL ON REQUEST**

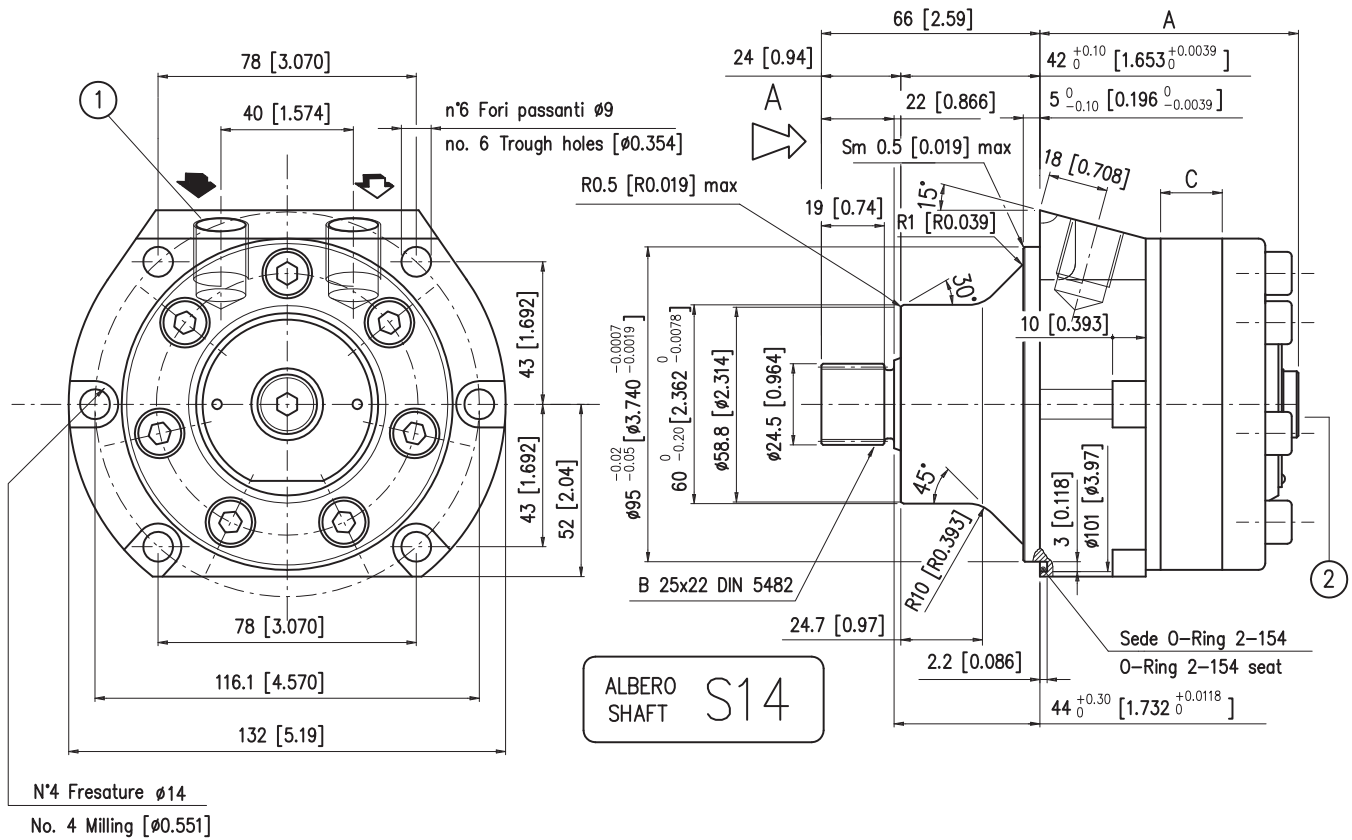

- 1) N° 2 fori di alimentazione 3/8 G (BSPP) profondità filetto 17 mm  
No. 2 3/8 G (BSPP) main ports thread depth 0.66 in.
- 2) Drenaggio motore 1/4 G (BSPP) profondità filetto 15 mm Max  
1/4 G (BSPP) motor drain thread depth 0.59 in Max

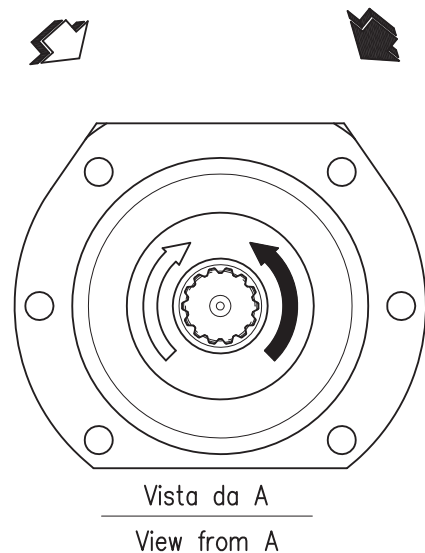

		BRZL 50	BRZL 65	BRZL 80	BRZL 100	BRZL 130	BRZL 160	BRZL 200	BRZL 250	BRZL 315	BRZL 400
A	mm [in]	67.5 [2.65]	69.8 [2.74]	72.5 [2.85]	75.9 [2.98]	80.3 [3.16]	86.3 [3.39]	93.3 [3.67]	102 [4.01]	113.3 [4.46]	126.9 [4.99]
C	mm [in]	9 [0.354]	11.3 [0.444]	14 [0.551]	17.4 [0.68]	21.8 [0.85]	27.8 [1.09]	34.8 [1.37]	43.5 [1.71]	54.8 [2.15]	68.38 [2.69]
Peso Weight	kg [lb]	5.6 [12.3]	5.8 [12.7]	5.9 [13.0]	6.2 [13.7]	6.5 [14.3]	6.8 [15.0]	7.1 [15.6]	7.6 [16.8]	8.3 [18.3]	9.5 [20.9]

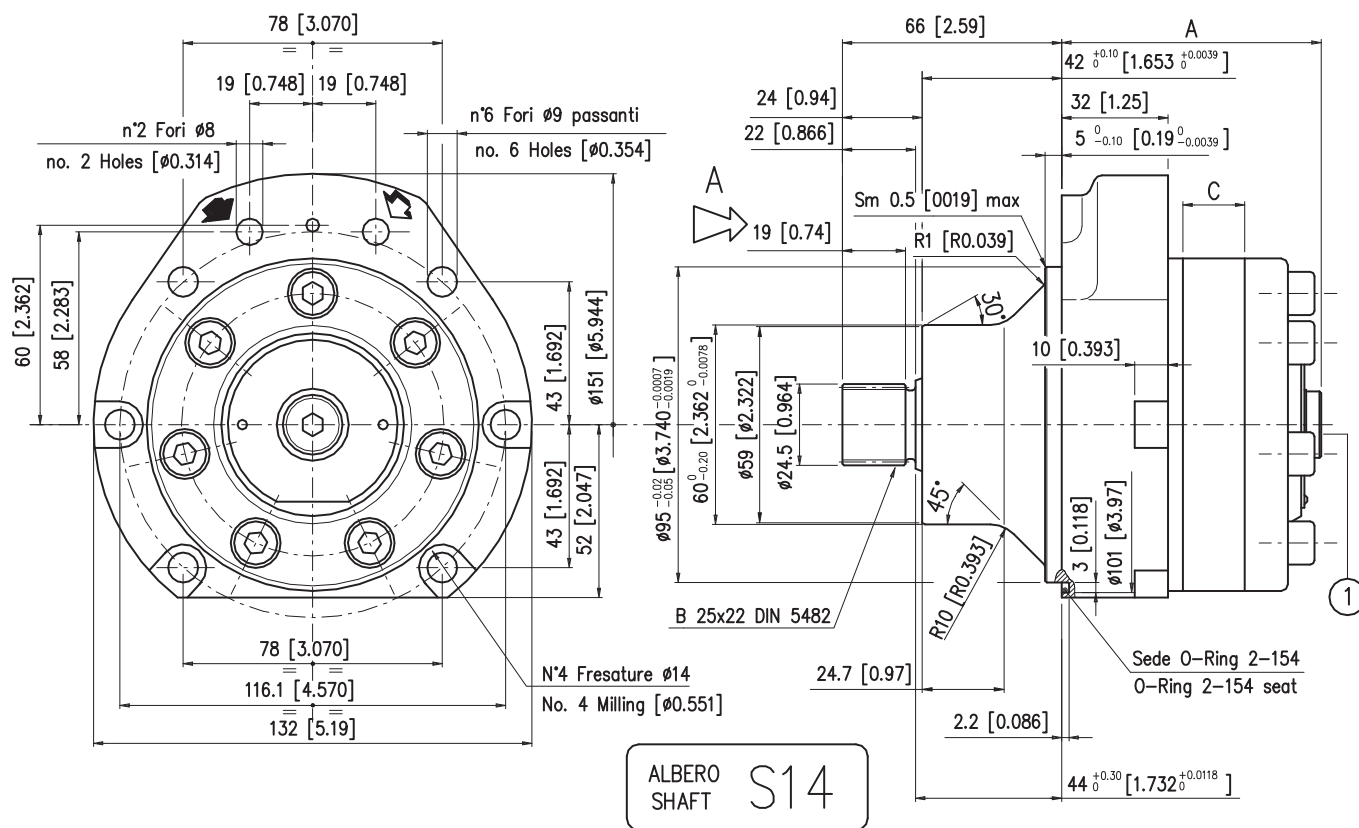

1) Drenaggio motore 1/4 G (BSPP) profondità filetto 15 mm Max  
1/4 G (BSPP) motor drain thread depth 0.59 in Max

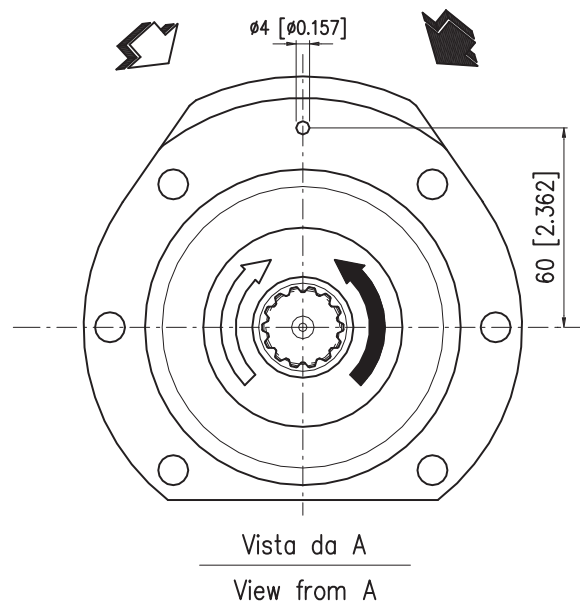

Per l'alimentazione del motore sono disponibili le due valvole VCT11-SF e VCT11-AF ed il collettore modulare CMZ-SF e CMZ-AF.  
VCT11-SF and VCT11-AF valves and CMZ-SF and CMZ-AF manifold are available to allow motor connection.

		BRZV 50	BRZV 65	BRZV 80	BRZV 100	BRZV 130	BRZV 160	BRZV 200	BRZV 250	BRZV 315	BRZV 400
<b>A</b>	mm [in]	67.5 [2.65]	69.8 [2.74]	72.5 [2.85]	75.9 [2.98]	80.3 [3.16]	86.3 [3.39]	93.3 [3.67]	102 [4.01]	113.3 [4.46]	126.9 [4.99]
<b>C</b>	mm [in]	9 [0.354]	11.3 [0.444]	14 [0.551]	17.4 [0.68]	21.8 [0.85]	27.8 [1.09]	34.8 [1.37]	43.5 [1.71]	54.8 [2.15]	68.38 [2.69]
<b>Peso Weight</b>	kg [lb]	5.6 [12.3]	5.8 [12.7]	5.9 [13.0]	6.2 [13.7]	6.5 [14.3]	6.8 [15.0]	7.1 [15.6]	7.6 [16.8]	8.3 [18.3]	9.5 [20.9]

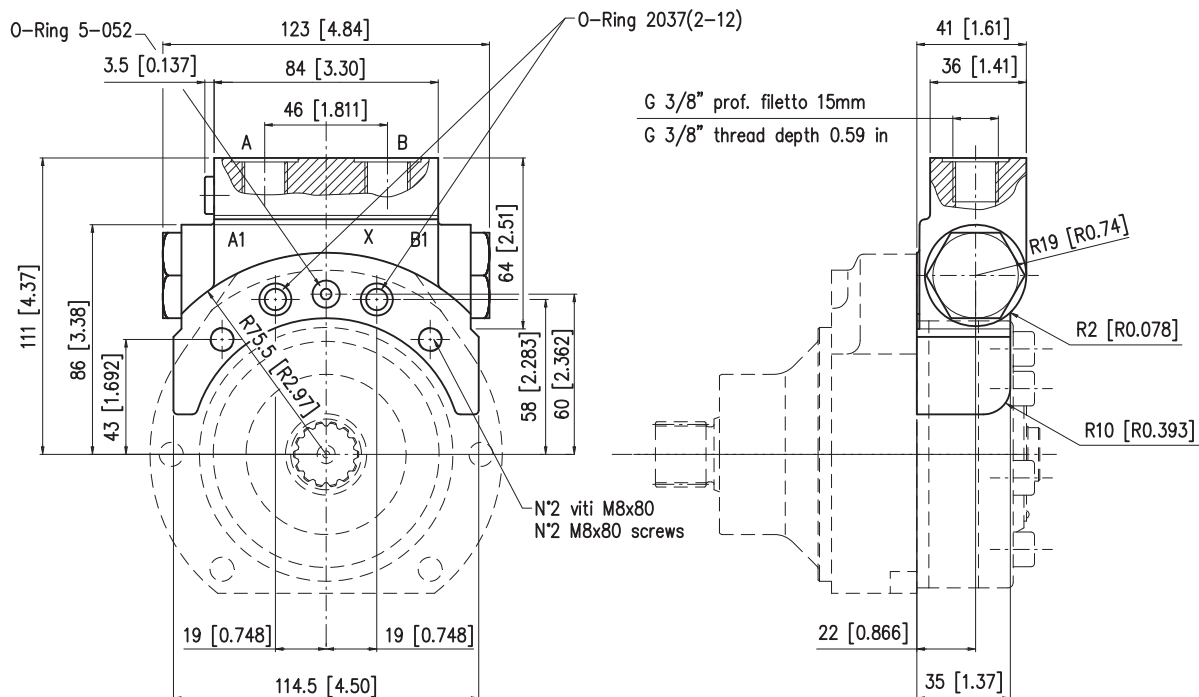

**VERSIONE METRICA**  
**METRIC VERSION**

**VERSIONE SAE**  
**SAE VERSION**

A-B = 3/8 G (BSPP) prof. filetto 15mm  
3/8 G (BSPP) thread depth [0.59 in]

A-B = 3/4-16 UNF prof. filetto 15mm  
3/4-16 UNF thread depth [0.59 in]

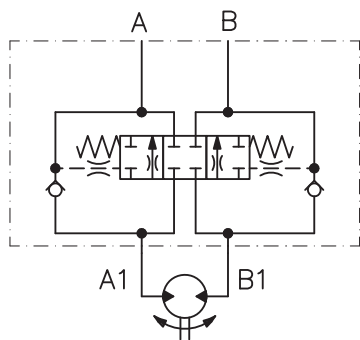

**VCT 11 - SF**

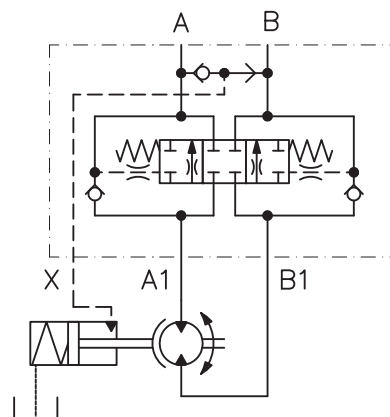

**VCT 11 - AF**

**Peso - Weight (kg [lb])**

**1.8 [3.97]**

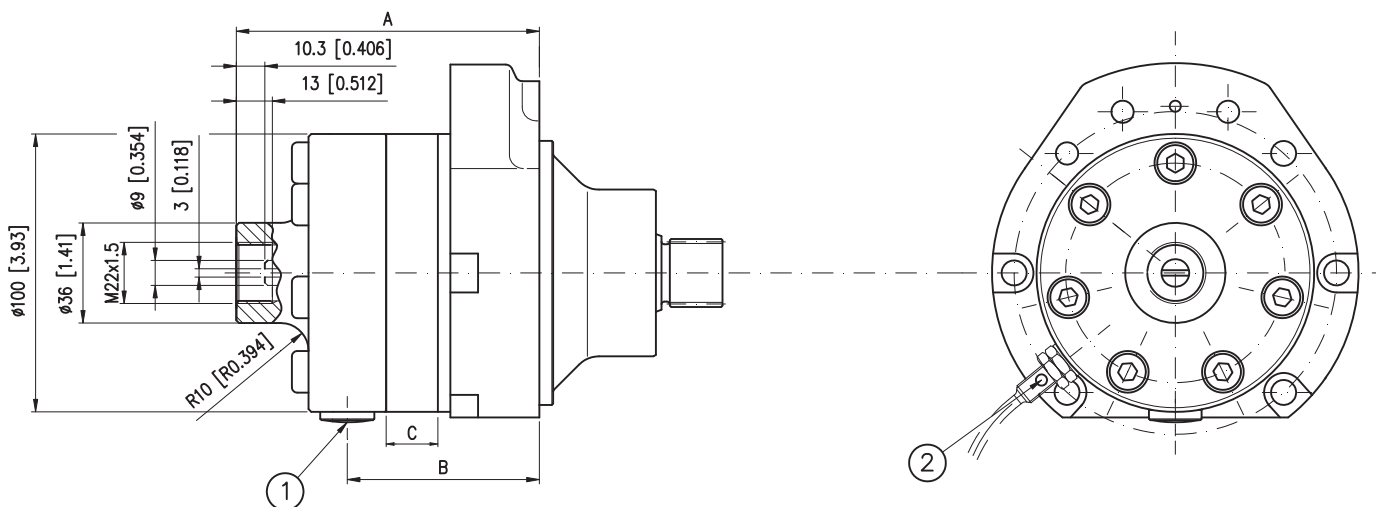

1) Drenaggio motore 1/4 G (BSPP) profondità 12 mm  
1/4 G (BSPP) drain port thread depth 0.472 in

2) Attacco sensore M8x1  
Sensor connection M8x1

**ATTENZIONE:**

- L'alberino contagiri ha velocità pari a 6 volte quella dell'albero primario del motore e senso di rotazione opposto.
- N.B.: Non sono accettati carichi assiali o radiali sull'albero contagiri. Coppia massima trasmissibile 1 Nm.
- Il motore viene fornito senza il sensore elettronico: se necessario, richiederlo in fase di ordinazione.
- Pressione massima ammessa sulla guarnizione dell'albero contagiri con drenaggio chiuso: 25 bar.

**WARNING:**

- Tacho shaft has a 6 times higher revolution speed than the motor shaft and opposite direction of rotation.
- NOTE: Axial or radial load on tacho shaft must be avoided. Max torque on tacho 1 Nm [0.737 lbf-ft].
- The electronic sensor is not supplied: if required, please state it clearly on order form.
- Max pressure admissible on the shaft seal with closed drain port 25 bar [362 psi].

		BRZV 50	BRZV 65	BRZV 80	BRZV 100	BRZV 130	BRZV 160	BRZV 200	BRZV 250	BRZV 315	BRZV 400
<b>A</b>	mm [in]	100 [3.93]	102.3 [4.02]	105 [4.13]	108.4 [4.26]	112.8 [4.44]	118.8 [4.67]	125.8 [4.95]	134.5 [5.29]	145.8 [5.74]	159.4 [6.27]
<b>B</b>	mm [in]	60.4 [2.37]	62.7 [2.46]	65.4 [2.57]	68.8 [2.70]	73.2 [2.88]	79.2 [3.11]	86.2 [3.39]	94.9 [3.73]	106.2 [4.18]	119.8 [4.71]
<b>C</b>	mm [in]	9 [0.354]	11.3 [0.444]	14 [0.551]	17.4 [0.68]	21.8 [0.85]	27.8 [1.09]	34.8 [1.37]	43.5 [1.71]	54.8 [2.15]	68.38 [2.69]
<b>Peso Weight</b>	kg [lb]	6.1 [13.4]	6.3 [13.8]	6.4 [14.1]	6.7 [14.8]	7.0 [15.4]	7.3 [16.1]	7.6 [16.8]	8.1 [17.9]	8.8 [19.4]	9.5 [20.9]

**CARATTERISTICHE TECNICHE DEL SENSORE ELETTRONICO**  
**ELECTRONIC SENSOR TECHNICAL FEATURES**

Segnale in uscita versione elettronica  
Output signal electronic tacho

Numero d'impulsi per giro = 90  
Principio di funzionamento induttivo  
Funzione di uscita PNP  
Tensione nominale 10-65 V d.c.  
Caricabilità massima 300 mA  
Frequenza massima 10000 Hz  
Campo di temperatura -25C +85C  
Grado di protezione IP 67

Number of pulses per revolution = 90  
Inductive principle  
Output current PNP  
Voltage 10-65 V d.c.  
Max load 300 mA  
Max frequency 10000 Hz  
Temperature range -25C +85C  
Enclosure IP 67

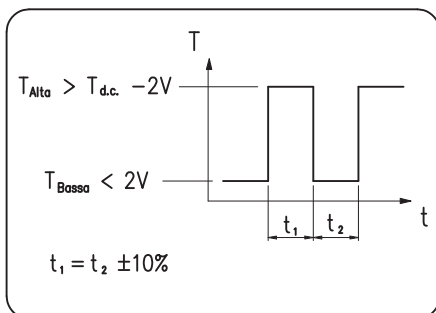

Versioni disponibili:  
• Sensore con cavo a tre fili lunghezza 2 metri (cod.424.0050.0000)  
• Sensore con attacco per connettore tipo binder (cod.424.0060.0000) + connettore tipo binder  
• con cavo a tre fili lunghezza 5 metri (cod.424.0080.0000)

Available versions:  
• Sensor with 2 metres three wires cable (cod.424.0050.0000)  
• Sensor with binder plug connection (cod.424.0060.0000) + binder connecting  
• plug with 5 metres three wires cable (cod.424.0080.0000)



**Collettore modulare CMZ senza sblocco freno (SF)**  
**Manifold CMZ without brake opening port (SF)**

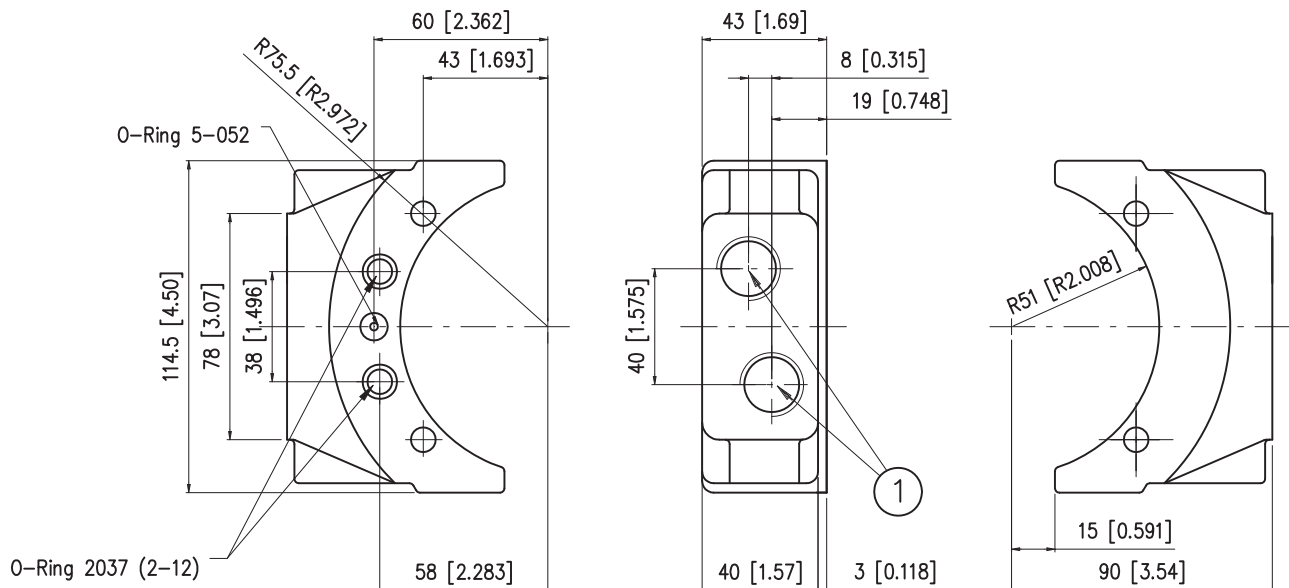

- 1) N° 2 Fori d'alimentazione 1/2 G (BSPP) Prof.fil. 19 mm  
N°2 1/2 G (BSPP) main ports thread depth 0.74 in

**Collettore modulare CMZ con sblocco freno (AF)**  
**Manifold CMZ with brake opening port (AF)**

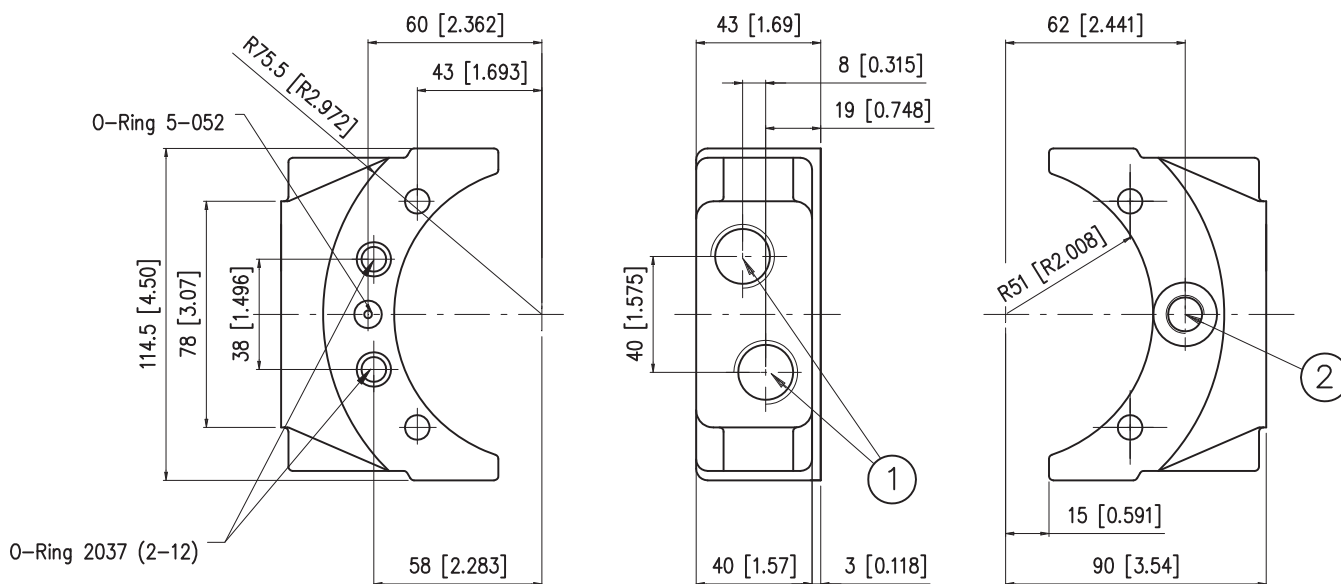

- 1) N° 2 Fori d'alimentazione 1/2 G (BSPP) Prof.fil. 19 mm  
N°2 1/2 G (BSPP) main ports thread depth 0.74 in  
2) Apertura freno 1/4 G (BSPP) Prof.fil. 13 mm  
1/4 G (BSPP) drain port thread depth 0.511 in

# MASSIMA PRESSIONE AMMESSA SULLA GUARNIZIONE ALBERO MAX PERMISSIBLE SHAFT PRESSURE

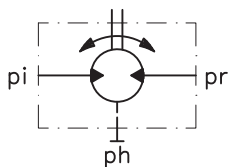
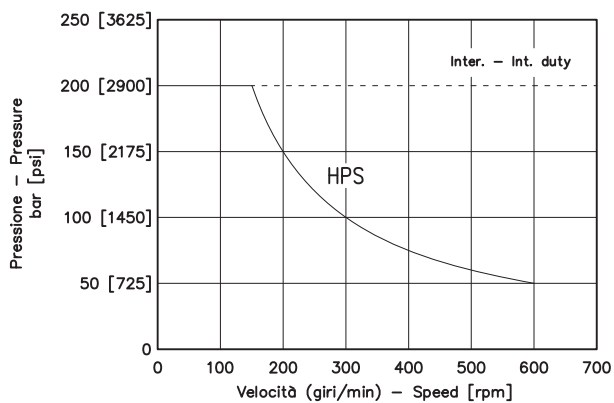

I motori BRZ sono forniti nella versione con guarnizioni ad alta pressione (HPS). Nei motori BRZ non sono presenti le valvole interne di drenaggio. La pressione sulla guarnizione ( $ph$ ) è la media tra le pressioni di alimentazione e di scarico del motore. Se  $ph$  supera il valore massimo ammesso (vedi grafico a fianco) occorre aprire il drenaggio.

Motors are supplied in HPS seal version (HPS) BRZ motors don't feature build-in check valves. The ( $ph$ ) pressure on the seal is the average between inlet and outlet pressure. If  $ph$  exceeds rated figures (see graph on side), the drain line must be connected.

$$Ph = \frac{pi + pr}{2} [bar]$$

$ph$  = pressione in carcassa  
 $pi$  = pressione di alimentazione  
 $pr$  = pressione di scarico

$ph$  = housing pressure  
 $pi$  = inlet. pressure  
 $pr$  = outlet pressure



**BREVINI<sup>®</sup>**

*Motion Systems*

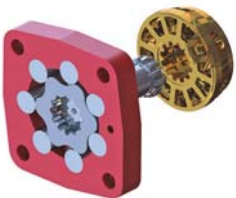
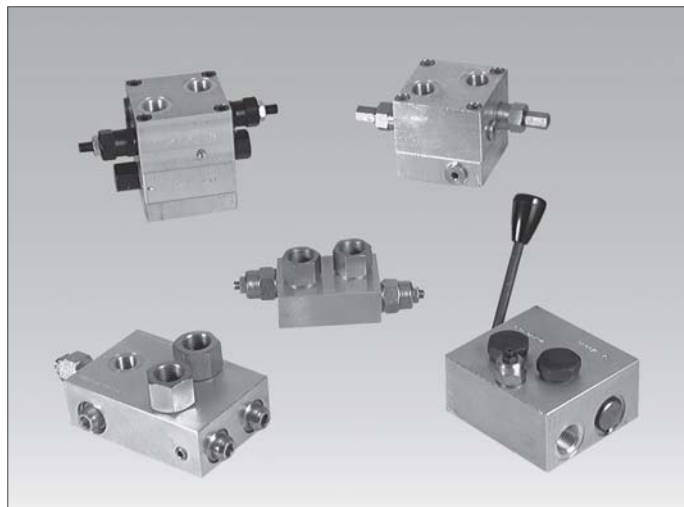

---

## **VALVOLE ED ACCESSORI**

---

## **VALVES AND ACCESSORIES**

---

**BGM**

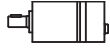

VAF 06-D

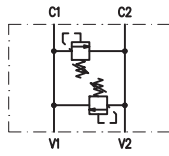

**BG**

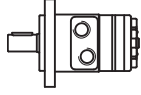

VAF 08-D  
VAF E8-D

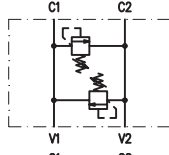

**BR**

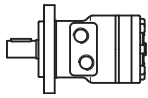

VAAF 31

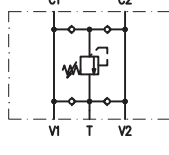

**AR**

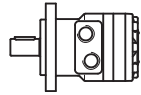

VAF 08-D/AF

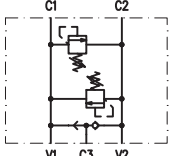

**HR**

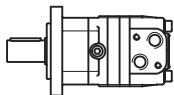

VAAF 09/40

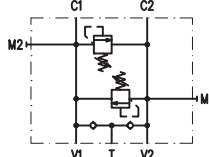

**HT**

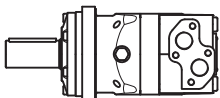

VCD2 10-S/AF

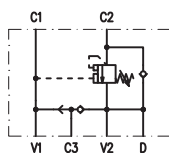

*Le valvole presenti nel catalogo, sono in versione metrica.  
Per versione SAE prego contattarci.*  
The valves showed on this catalogue, are in metric version.  
For SAE version, please contact us.

VCD 08-S/AF  
VCD E8-S/AF

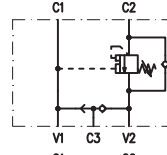

VCR1 08-D/AF  
VCR1 E8-D/AF

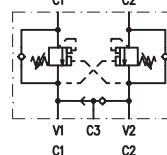

VCR1 08-D/AF-LDP  
VCR1 E8-D/AF-LDP

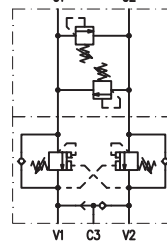

VCR1 09-D/AF

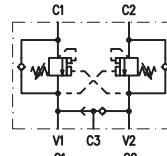

VCR1 09-D/AF-LDP

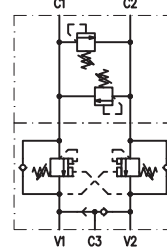

VCD1 09-S/AF

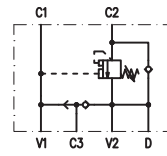

VCR1 10-D/AF

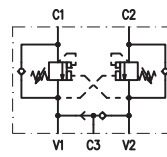

VSC

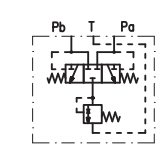

VRP 09

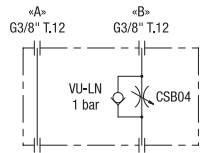

VSC

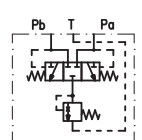

# VAF 06 - D



Valvola di massima pressione flangiabile ai motori idraulici serie BGM. Protegge il motore da eccessivi valori di pressione, in particolare nelle fasi di avvio, arresto ed inversione del moto. Il tipo standard è a doppia cartuccia (VAF 06-D). Qualora il motore operi in un solo senso di rotazione è possibile fornire la valvola provvista di una sola cartuccia (VAF 06-S). La valvola normalmente viene fornita non tarata. E' possibile la fornitura della valvola già tarata, in tal caso precisare al momento dell'ordine: valore di taratura e relativa portata. Campo di taratura ammissibile: da 50 a 150 bar.

Pressure relief valve, flangeable on BGM series hydraulic motors which protects the motor from excessive peak pressure, especially at start, stop and inversion. Double cartridge (VAF 06-D) as standard. For shaft rotation in one direction only, a single cartridge version (VAF 06-S) is available as well. If not requested, valves are supplied not set. Any setting requirement must be specified at ordering by stating pressure and flow. Setting range between 50 and 150 bar [725 and 2175 psi].

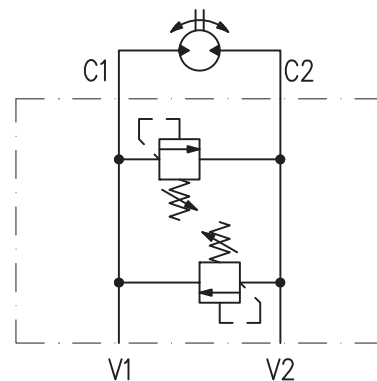
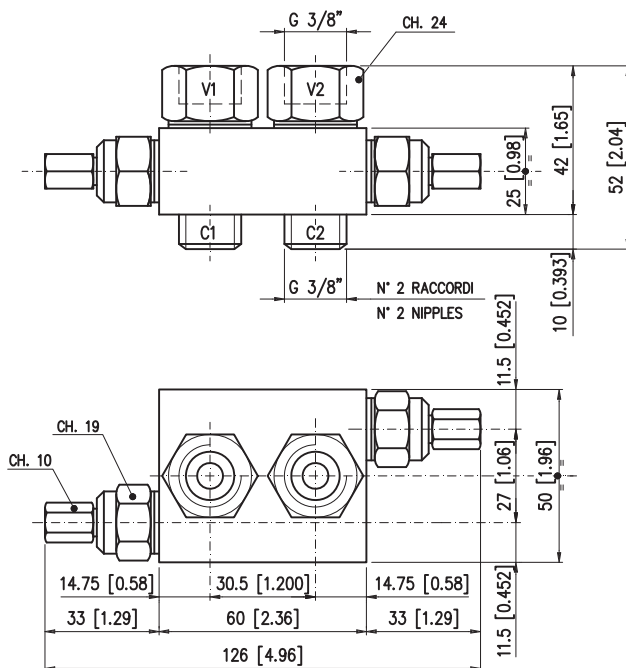

VAF 06 - S (50÷150 bar / 725÷2175 psi) Codice/Code: 521.3025.0111  
 VAF 06 - D (50÷150 bar / 725÷2175 psi) Codice/Code: 521.3025.0121

Pressione max esercizio Max working pressure	250 bar [3625 psi]
Portata max Max flow	20 l/min [5,28 U.S. gpm]
Peso Weight	0,2 kg [0,4 lb]

# VAF 08 - D

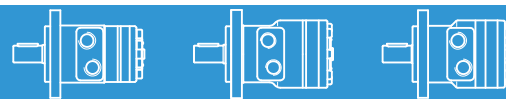

Valvola di massima pressione, flangiabile ai motori idraulici serie AR, BR, BG. Protegge il motore da eccessivi valori di pressione, in particolare nelle fasi di avvio, arresto ed inversione del moto. Il tipo standard è a doppia cartuccia (VAF 08-D). Qualora il motore operi in un solo senso di rotazione è possibile fornire la valvola provvista di una sola cartuccia (VAF 08-S). Il campo di taratura standard è da 70 a 200 bar. E' disponibile anche la versione da 30 a 70 bar. La valvola normalmente viene fornita non tarata. E' possibile la fornitura della valvola già tarata, in tal caso precisare al momento dell'ordine: valore di taratura e relativa portata.

Pressure relief valve, flangeable on AR, BR, BG series motors which protects the motor from excessive peak pressure, particularly at start, stop and inversion. Double cartridge (VAF 08-D) as standard. For shaft rotation in one direction only, a single cartridge version (VAF 08-S) is available as well. If not requested, valves are supplied not set. Any setting requirement must be specified at ordering by stating pressure and flow. Two setting ranges are available: 70 to 200 bar [1015 to 2900 psi] as standard and 30 to 70 bar [435 to 1015 psi] as optional.

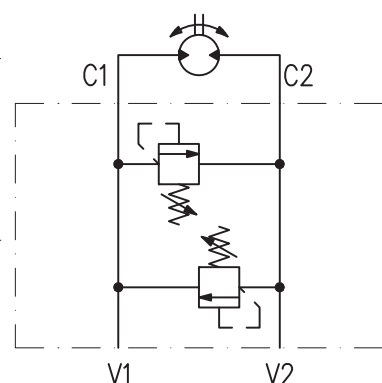
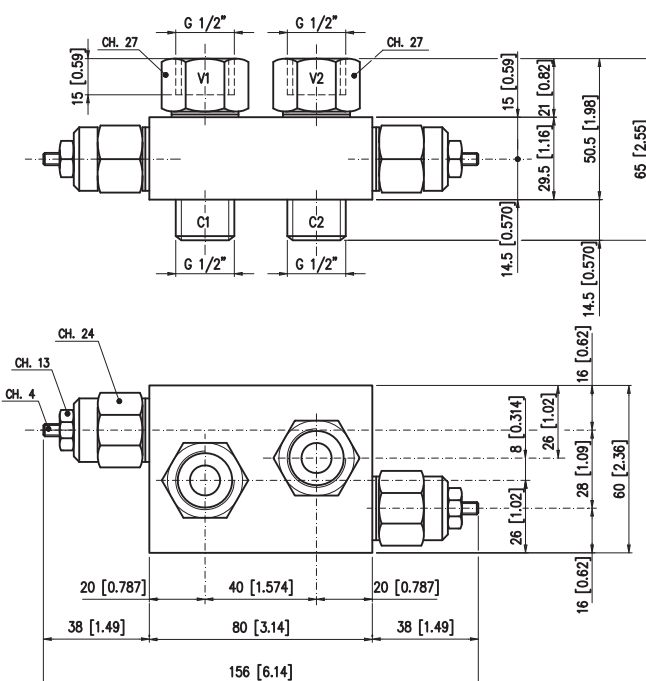

VAF 08 - S (30÷70 bar / 435÷1015 psi) Codice/Code: 521.3030.1111  
 VAF 08 - D (30÷70 bar / 435÷1015 psi) Codice/Code: 521.3030.1121  
 VAF 08 - S (70÷200 bar / 1015÷2900 psi) Codice/Code: 521.3030.0111  
 VAF 08 - D (70÷200 bar / 1015÷2900 psi) Codice/Code: 521.3030.0121

Pressione max esercizio Max working pressure	250 bar [3625 psi]
Portata max Max flow	50 l/min [13,2 U.S. gpm]
Peso Weight	0,8 kg [1,76 lb]

# VAF E8 - D



Valvola di massima pressione, flangiabile ai motori idraulici serie , BR E, BG E. Protegge il motore da eccessivi valori di pressione, in particolare nelle fasi di avvio, arresto ed inversione del moto. Il campo di taratura standard è da 50 a 130 bar. E' disponibile anche la versione da 100 a 200 bar. La valvola normalmente viene fornita non tarata. E' possibile la fornitura della valvola già tarata, in tal caso precisare al momento dell'ordine: valore di taratura e relativa portata.

Pressure relief valve, flangeable on BR E, BG E series motors which protects the motor from excessive peak pressure, particularly at start, stop and inversion. If not requested, valves are supplied not set. Any setting requirement must be specified at ordering by stating pressure and flow. Two setting ranges are available: 50 to 130 bar [725 to 1885 psi] as standard and 100 to 200 bar [1450 to 2900 psi] as optional.

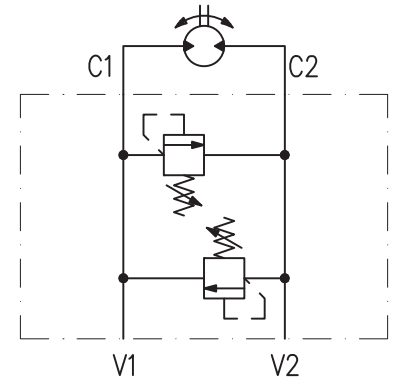
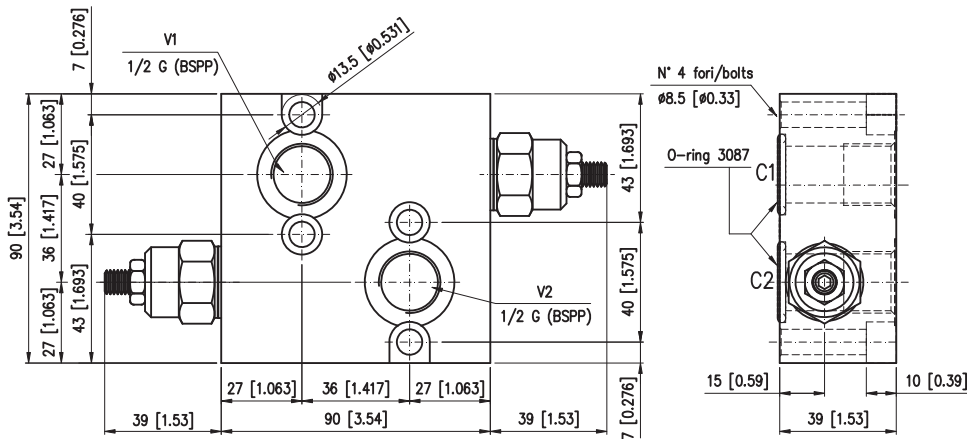

**Attenzione: quantità minima per ordine 20 pezzi**  
**Warning: minimum quantity for order 20 pieces**

VAF E8 - D (100÷200 bar / 1450÷2900 psi) Codice/Code: SPO00000206  
 VAF E8 - D (50÷130 bar / 725÷1885 psi) Codice/Code: SPO00000207

Pressione max esercizio Max working pressure	250 bar [3625 psi]
Portata max Max flow	50 l/min [13,2 U.S. gpm]
Peso Weight	0,8 kg [1,76 lb]

# VAF 09 - D

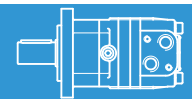

Valvola di massima pressione doppia, flangiabile ai motori idraulici serie HR. Protegge il motore da eccessivi valori di pressione, in particolare nelle fasi di avvio, arresto ed inversione del moto. Il campo di taratura standard è da 100 a 200 bar. E' disponibile anche la versione da 50 a 100 bar. La valvola normalmente viene fornita non tarata. E' possibile la fornitura della valvola già tarata, in tal caso precisare al momento dell'ordine: valore di taratura e relativa portata.

Pressure relief valve flangeable on HR series motors which protects the motor from excessive peak pressure build-up particularly at start, stop and inversion. If not requested, valves are supplied not set. Any setting requirement must be specified at ordering by stating pressure and flow. Two setting ranges are available: 100 to 200 bar [1450 to 2900 psi] as standard and 50 to 100 bar [725 to 1450 psi] as optional.

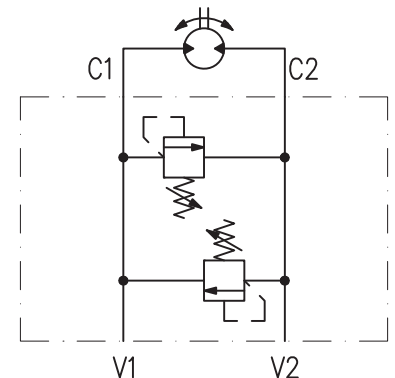
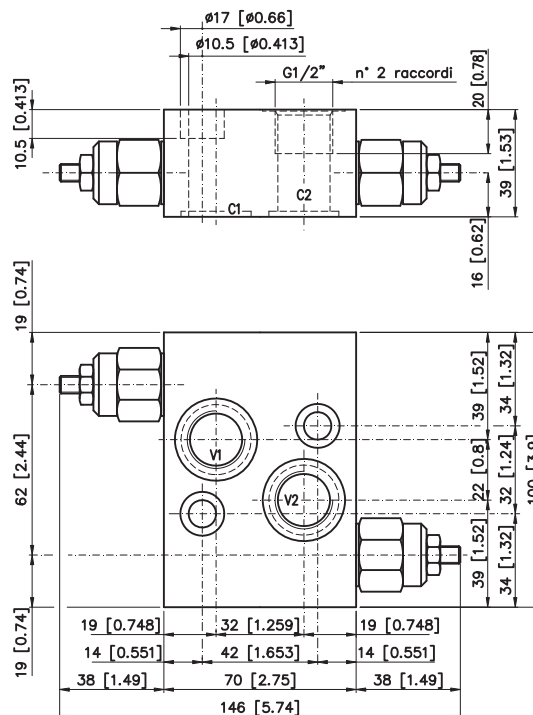

VAF 09 - D (100÷200 bar / 1450÷2900 psi) Codice/Code: SPO00000209  
 VAF 09 - D (50÷100 bar / 725÷1450 psi) Codice/Code: SPO00000210

Pressione max esercizio Max working pressure	250 bar [3625 psi]
Portata max Max flow	50 l/min [13,2 U.S. gpm]
Peso Weight	0,8 kg [1,76 lb]

# VAAF 31

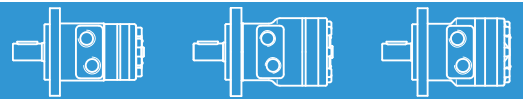

Valvola antiurto ad anticavitazione flangiabile ai motori serie AR, BR, BG. Offre protezione al motore quando aziona una massa inerziale rilevante, evita eccessivi valori di pressione e la possibile cavitazione nelle fasi di arresto ed inversione del moto. La valvola normalmente viene fornita non tarata. Il campo di taratura standard è da 50 a 130 bar (opzionale 100+250).

Anticavitation and antishock valve, flangeable on AR, BR, BG motors, which protects from excessive peak pressure when driving a high inertia mass, as well as protects from cavitation at stop and inversion. If not requested, valves are supplied not set. The standard setting range is 50+130 bar [725+1885 psi] (100+250 bar [1450+3625 psi] on option).

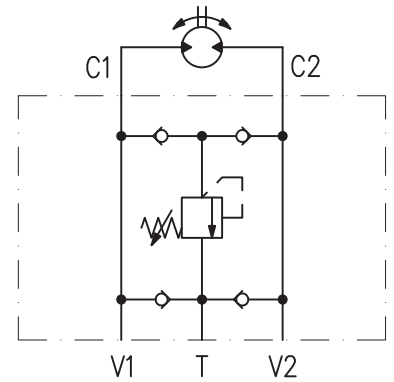
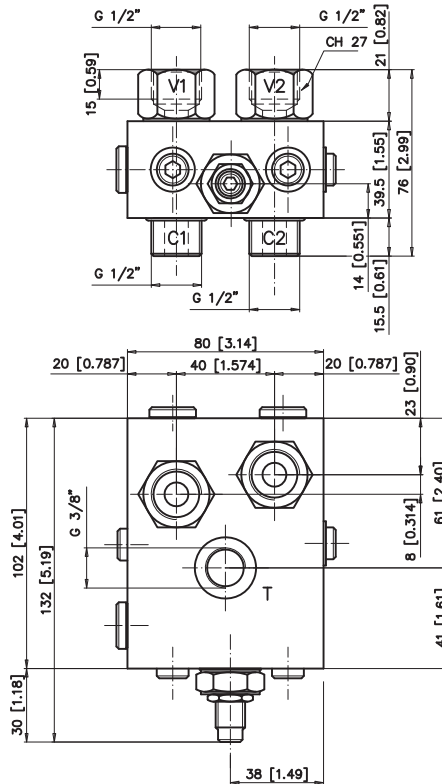

VAAF 31 (50+130 bar / 725+1885 psi) Codice/Code: 521.2030.0114  
 VAAF 31 (100+250 bar / 1450+3625 psi) Codice/Code: 521.2030.0115

Pressione max esercizio Max working pressure	<b>250 bar</b> <b>[3625 psi]</b>
Portata max Max flow	<b>45 l/min</b> <b>[11,88 U.S. gpm]</b>
Peso Weight	<b>1,2 kg</b> <b>[2,64 lb]</b>

# VAAF 09/40

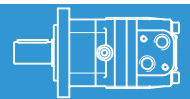

Valvola antiurto ed anticavitazione flangiabile ai motori serie HR. Offre protezione al motore quando aziona una massa inerziale rilevante, evita eccessivi valori di pressione e la possibile cavitazione nelle fasi di arresto ed inversione del moto. La valvola normalmente viene fornita non tarata. Il campo di taratura è da 50 a 210 bar (incremento di pressione: 47 bar/giro vite).

Anticavitation and antishock valve, flangeable on HR motors, that protects from excessive pressure buildup when driving a high inertial mass, as well as protect from cavitation at stop and inversion. Unless otherwise requested, valves are supplied not set. The setting range is 50+210 bar [725+3045 psi] (pressure increase: 47 bar [681 psi] screw turn).

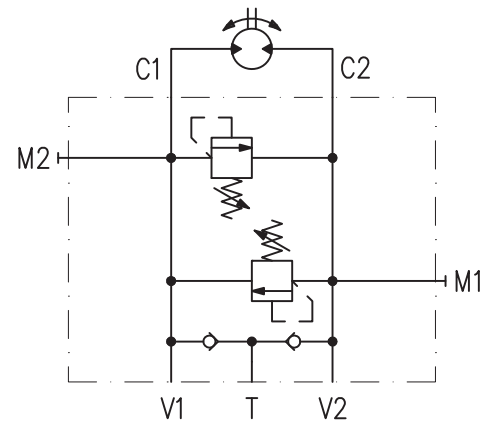
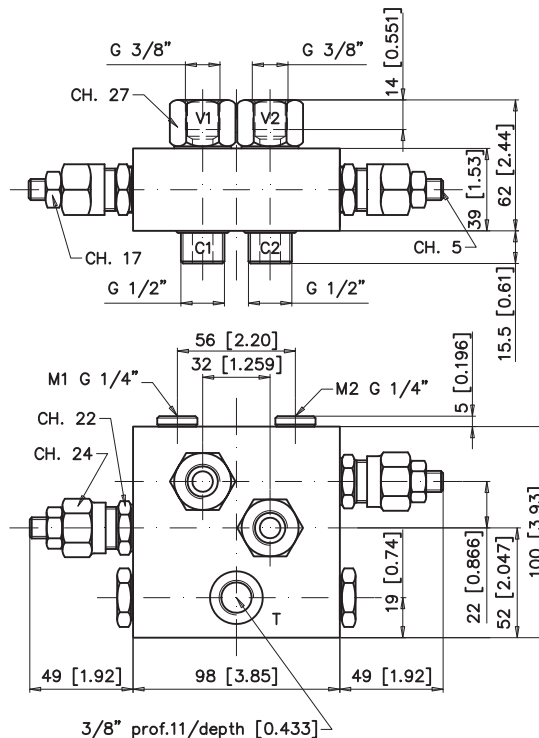

VAAF 09/40 Codice/Code: 521.2040.0123

Pressione max esercizio Max working pressure	<b>210 bar</b> <b>[3045 psi]</b>
Portata max Max flow	<b>40 l/min</b> <b>[10,5 U.S. gpm]</b>
Peso Weight	<b>1,7 kg</b> <b>[3,74 lb]</b>



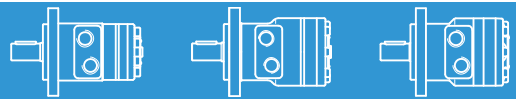

Valvola avente dispositivo di prelievo del fluido in pressione, è flangiabile ai motori serie AR, BR, BG. Normalmente utilizzata per comando diretto di freni idraulici negativi ed in particolare sui motori con freno incorporato serie ARF e serie FP. Non essendo ammessa la frenatura dinamica dei motori con freno incorporato, l'uso della valvola AF deve essere riservato alle sole applicazioni con velocità estremamente limitate, comunque in condizioni di funzionamento quasi statico. Per garantire l'intervento sicuro del freno in posizione centrale di riposo del distributore gli effetti devono essere collegati a scarico (Distributore in centro aperto).

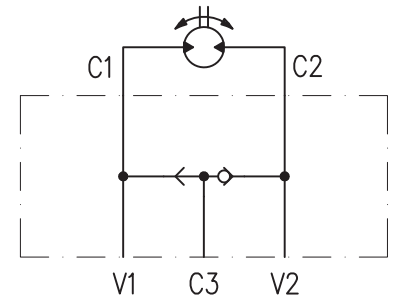
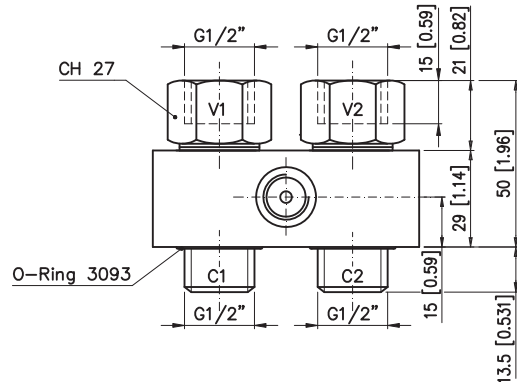

Shuttle-valve flangeable on AR, BR, BG motors, which diverts oil under pressure to negative brakes in order to disengage them. Suitable for ARF brake motors as well as for FP brake. The brakes featured by the ARF are, like the FP brakes, for static use. Hence the AF shuttle valve can be used only for those applications where the brake will not be used as dynamic. An open centre control valve bank is recommended.

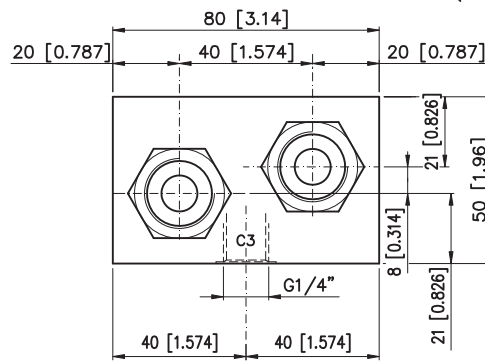

Pressione max esercizio Max working pressure	<b>250 bar</b> <b>[3625 psi]</b>
Portata max Max flow	<b>60 l/min</b> <b>[15,8 U.S. gpm]</b>
Peso Weight	<b>0,5 kg</b> <b>[1,10 lb]</b>

AF Codice/Code: 521.9010.0000

# VAF 08 – D/AF

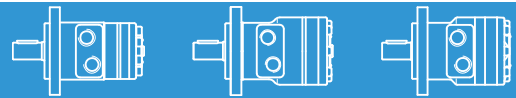

Valvola di massima pressione con selettore del fluido in pressione, flangiabile ai motori idraulici serie AR, BR, BG. Protegge il motore da eccessivi valori di pressione, in particolare nelle fasi di avvio, arresto ed inversione del moto. Il campo di taratura standard è da 70 a 200 bar. E' disponibile anche la versione da 30 a 70 bar. La valvola normalmente viene fornita non tarata. E' possibile la fornitura della valvola già tarata, in tal caso precisare al momento dell'ordine: valore di taratura e relativa portata.

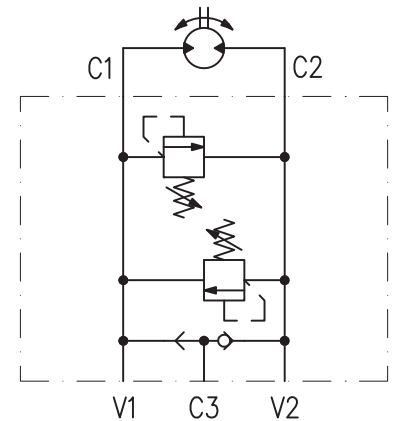
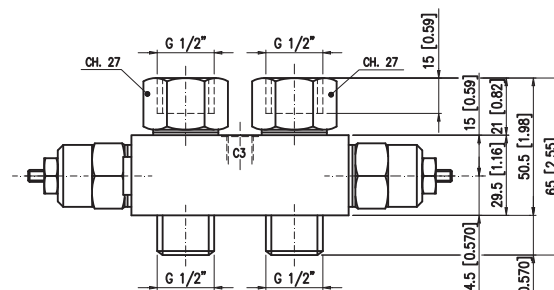

Pressure relief valve with shuttle valve, flangeable on AR, BR, BG series motors which protects the motor from excessive peak pressure particularly at start, stop and inversion. If not requested, valves are supplied not set. Any setting requirement must be specified at ordering by stating pressure and flow. Two setting ranges are available: 70 to 200 bar [1015 to 2900 psi] as standard and 30 to 70 bar [435 to 1015 psi] as optional.

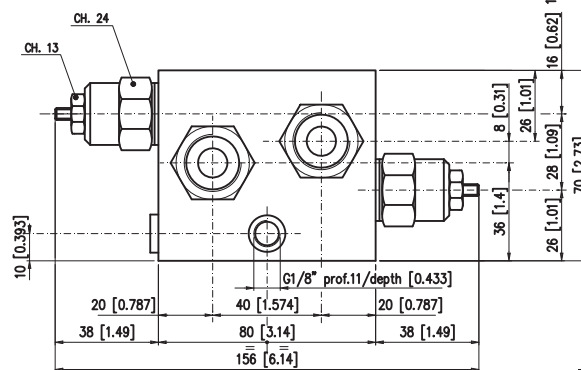

Pressione max esercizio Max working pressure	<b>250 bar</b> <b>[3625 psi]</b>
Portata max Max flow	<b>50 l/min</b> <b>[13,2 U.S. gpm]</b>
Peso Weight	<b>0,9 kg</b> <b>[1,98 lb]</b>

VAF 08 - D/AF (30÷70 bar / 435÷1015 psi) Codice/Code: 521.3070.1121

VAF 08 - D/AF (70÷200 bar / 1015÷2900 psi) Codice/Code: 521.3070.0121



# VAF 09 – D/AF

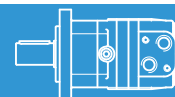

Valvola di massima pressione con selettore del fluido in pressione, flangiabile ai motori idraulici serie HR. Protegge il motore da eccessivi valori di pressione, in particolare nelle fasi di avvio, arresto ed inversione del moto. Il campo di taratura è da 100 a 280 bar. La valvola normalmente viene fornita non tarata. E' possibile la fornitura della valvola già tarata, in tal caso precisare al momento dell'ordine: valore di taratura e relativa portata.

Pressure relief valve with shuttle valve, flangeable on HR series motors which protects the motor from excessive peak pressure particularly at start, stop and inversion. If not requested, valves are supplied not set. Any setting requirement must be specified at ordering by stating pressure and flow. Setting ranges between 100 to 280 bar [1450 to 4060 psi].

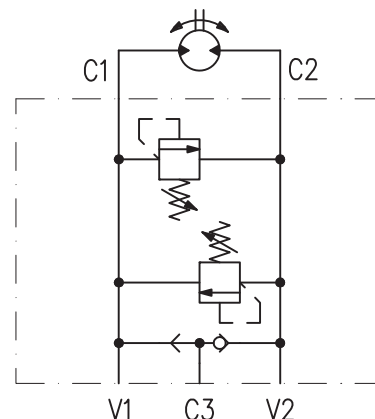
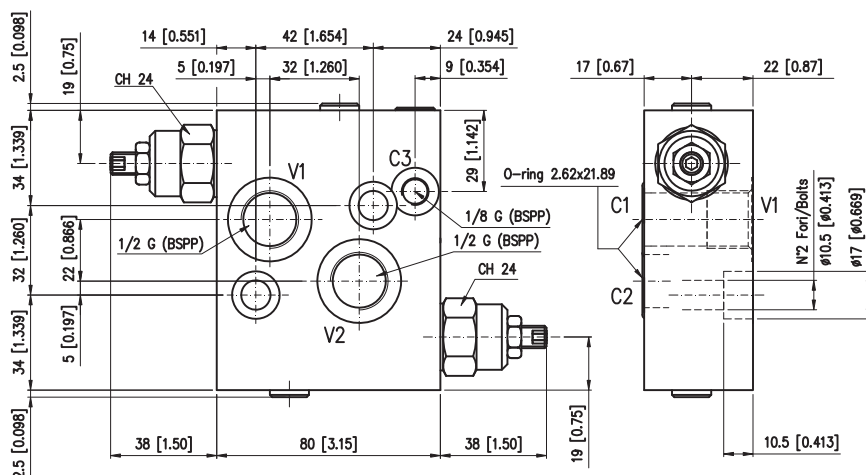

VAF 09 - D/AF (100÷280 bar / 1450÷4060 psi) Codice/Code: SPO0000211

Pressione max esercizio Max working pressure	<b>250 bar</b> <b>[3625 psi]</b>
Portata max Max flow	<b>50 l/min</b> <b>[13,2 U.S. gpm]</b>
Peso Weight	<b>0,9 kg</b> <b>[1,98 lb]</b>

# VCD 08 - S/AF

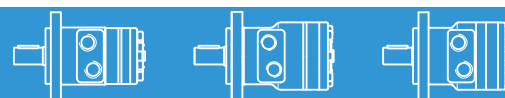

Valvola bilanciata di blocco e controllo discesa con selettore del fluido in pressione, singola, pilotata e flangiabile ai motori serie AR, BR, BG. Normalmente è impiegata per controllare la discesa del carico in argani con freno idraulico negativo a sbloccaggio oleodinamico, evitandone l'accelerazione incontrollata. Su tali applicazioni è idoneo l'impiego di motori con freno incorporato serie ARF e serie FP. La valvola normalmente viene fornita non tarata. Campo di taratura ammissibile: da 100 a 210 bar. Il rapporto di pilotaggio standard è 7:1 (opzionale 3,5:1).

Single-acting overcentre valve with shuttle valve, flangeable on AR, BR, BG motors. Usually flanged on winch driving brake motors with pressure released brake to control load lowering and avoid unwanted acceleration.

For such application ARF brake motors, as well as FP brakes, are widely employed. If not specified the valve is supplied not set. Setting range between 100 and 210 bar [1450 and 3045 psi]. The standard pilot ratio is 7:1 (3,5:1 on option).

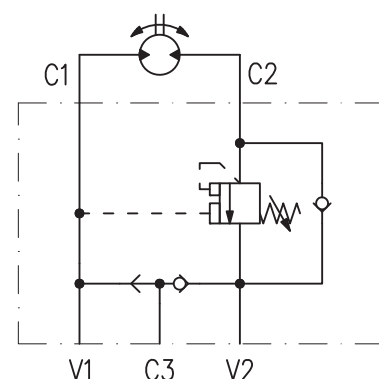
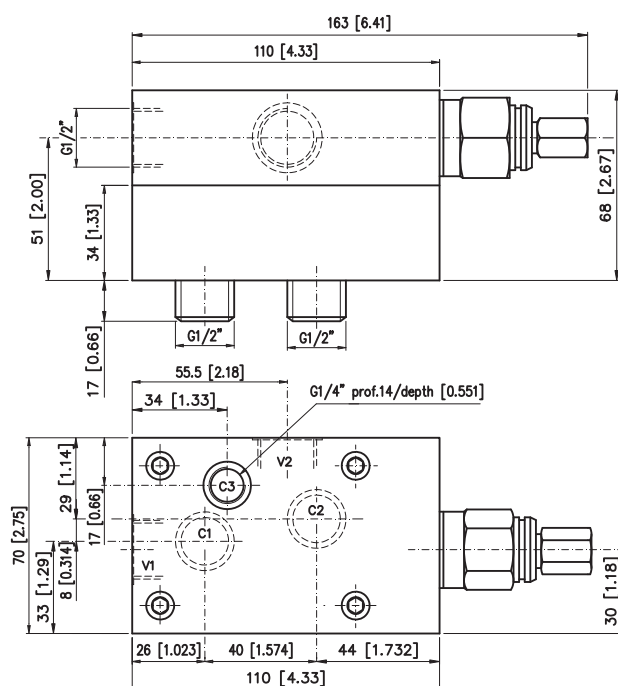

VCD 08 - S/AF (7:1) Codice/Code: 521.1060.0114  
VCD 08 - S/AF (3,5:1) Codice/Code: 521.1060.4114

Rapporto di pilotaggio Pilot ratio	<b>7:1</b> <b>3,5:1</b>
Pressione max esercizio Max working pressure	<b>250 bar</b> <b>[3625 psi]</b>
Portata max Max flow	<b>60 l/min</b> <b>[15,8 U.S. gpm]</b>
Peso Weight	<b>1,7 kg</b> <b>[3,74 lb]</b>

# VCD E8 - S/AF



Valvola bilanciata di blocco e controllo discesa con selettore del fluido in pressione, singola, pilotata e flangiabile ai motori serie BR E, BG E. Normalmente è impiegata per controllare la discesa del carico in argani con freno idraulico negativo a sbloccaggio oleodinamico, evitandone l'accelerazione incontrollata. La valvola normalmente viene fornita non tarata. Campo di taratura ammissibile: da 100 a 350 bar. Il rapporto di pilotaggio standard è 3,5:1.

Single-acting overcentre valve with shuttle valve, flangeable on BR E, BG E motors. Usually flanged on winch driving brake motors with pressure released brake to control load lowering and avoid unwanted acceleration. If not specified the valve is supplied not set. Setting range between 100 and 350 bar [1450 and 5075 psi]. The standard pilot ratio is 3,5:1.

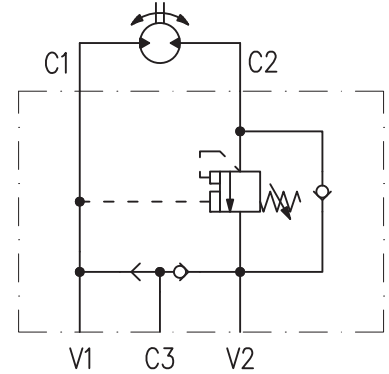
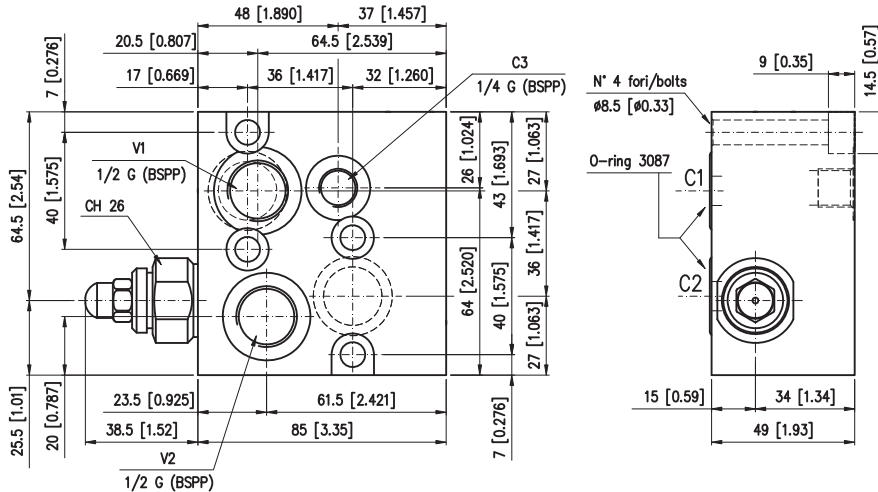

Rapporto di pilotaggio Pilot ratio	3.5:1
Pressione max esercizio Max working pressure	250 bar [3625 psi]
Portata max Max flow	50 l/min [13,2 U.S. gpm]
Peso Weight	1,7 kg [3,74 lb]

**Attenzione: quantità minima per ordine 20 pezzi**  
Warning: minimum quantity for order 20 pieces

VCD E8 - S/AF (3,5:1) Codice/Code: SPO00000208

# VCD1 09 - S/AF

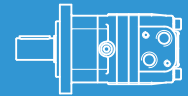

Valvola bilanciata di blocco e controllo discesa con selettore del fluido in pressione, singola, pilotata e flangiabile ai motori HR. Normalmente è impiegata per controllare la discesa del carico in argani con freno idraulico negativo a sbloccaggio oleodinamico, evitandone l'accelerazione incontrollata. La valvola normalmente viene fornita non tarata. La valvola è applicabile solo su impianti con distributore centro aperto. Campo di taratura ammissibile: da 100 a 210 bar.

Single acting overcentre valve with shuttle valve meant for HR motors, usually flanged on winch driving brake motors with pressure released brake to control load-lowering and avoid unwanted acceleration. It's widely used also to slow down the travelling of mobile machinery before the static brake engages. It operates, of course, in one direction only. If not specified the valve is supplied not set. It is possible to use the valve with open centre distributors. Setting range between 100 and 210 bar [1450 and 3045 psi].

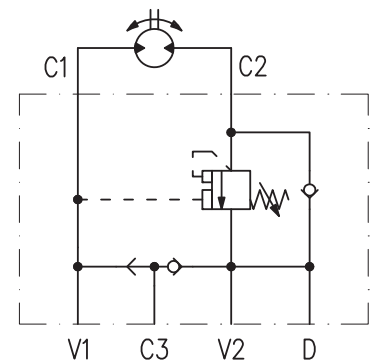
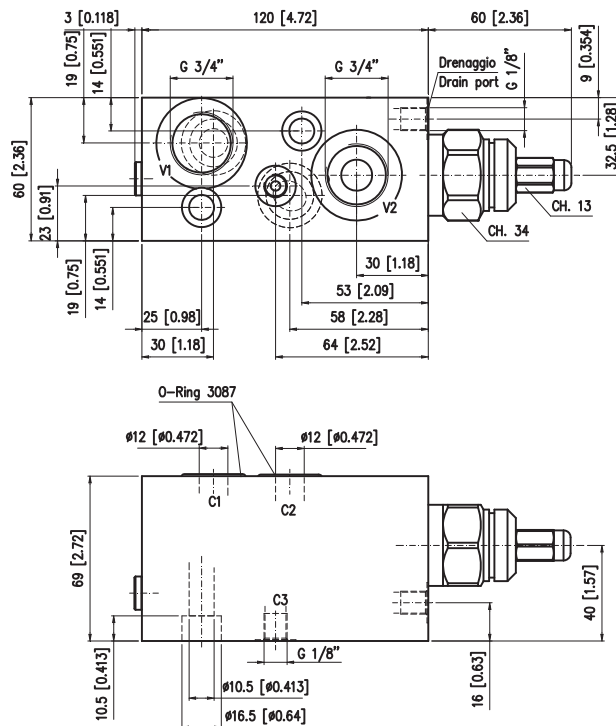

Rapporto di pilotaggio Pilot ratio	7:1 3:1
Pressione max esercizio Max working pressure	250 bar [3625 psi]
Portata max Max flow	75 l/min [19,8 U.S. gpm]
Peso Weight	1,5 kg [3,3 lb]

VCD1 09 - S/AF (7:1) Codice/Code: SPO00000155  
VCD1 09 - S/AF (3:1) Codice/Code: SPO00000156

# VCR1 08 - D/AF

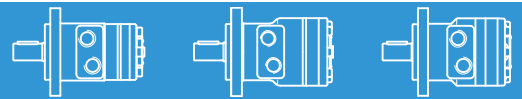

Valvola di controllo bilanciata a doppio effetto, di blocco, pilotata, con selettore del fluido in pressione e flangiabile ai motori serie AR, BR, BG. Assicura una frenatura progressiva ed il blocco delle masse in movimento evitando l'accelerazione incontrollata. Un opportuno dispositivo preleva il fluido in pressione, solitamente per comandare l'apertura di freni idraulici negativi. Un tipico impiego è su rotazioni di masse rilevanti (es torrette gru, piattaforme aeree, etc.). Su tali applicazioni è idoneo l'impiego di motori con freno incorporato serie ARF e serie FP. La valvola normalmente viene fornita non tarata. Campo di taratura ammissibile: da 30 a 220 bar.

Double-acting overcentre valve with shuttle valve, flangeable on AR, BR, BG motors. Usually flanged on winch driving brake motors with pressure released brake, to control load lowering and avoid unwanted acceleration. Slew drive control of cranes, aerial platforms, etcetera are common applications too. For such applications ARF brake motors, as well as FP brakes, are widely employed. If not specified the valve is supplied not set. Setting range between 30 and 220 bar [435 and 3190 psi].

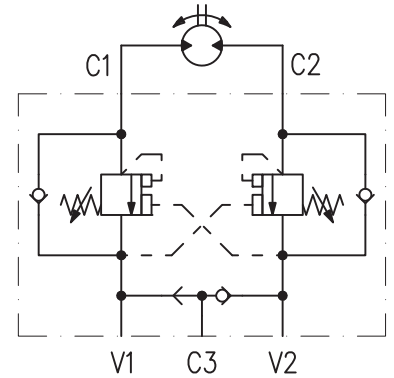
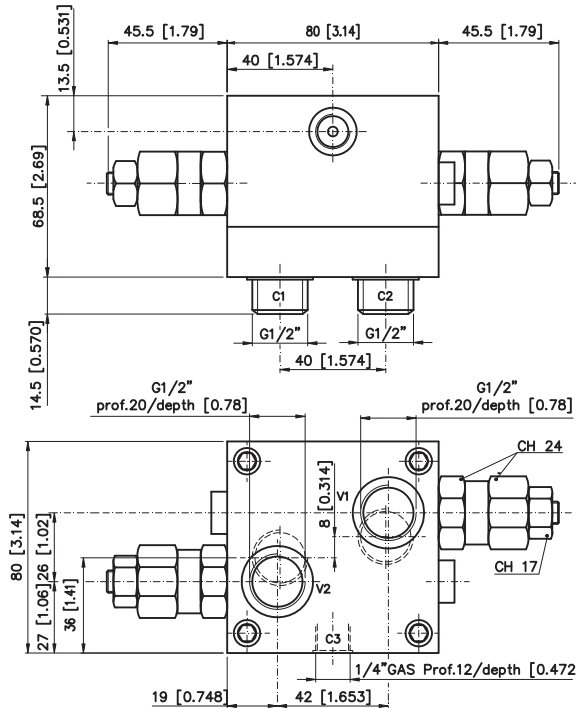

Rapporto di pilotaggio Pilot ratio	8:1 4,25:1
Pressione max esercizio Max working pressure	350 bar [5075 psi]
Portata max Max flow	60 l/min [15,8 U.S. gpm]
Peso Weight	1,8 kg [3,96 lb]

VCR1 08 - D/AF (4.25:1) Codice/Code: 521.2060.1007

VCR1 08 - D/AF (8:1) Codice/Code: 521.2061.1007

# VCR1 08 - D/AF - LDP

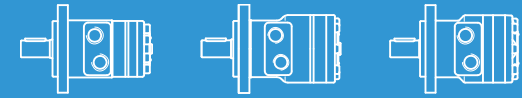

Valvola di controllo bilanciata a doppio effetto, di blocco, pilotata, con selettore del fluido in pressione e flangiabile ai motori serie AR, BR, BG. Assicura una frenatura progressiva ed il blocco delle masse in movimento, evitando l'accelerazione incontrollata. Un opportuno dispositivo preleva il fluido in pressione, solitamente per comandare l'apertura di freni idraulici negativi. Un tipico impiego è su rotazioni di masse rilevanti (es torrette gru, piattaforme aeree, etc.). Se utilizzata in apparecchiature per il sollevamento di carichi, è necessario tarare la valvola di massima generale dell'impianto o le valvole antiurto eventualmente presenti sul distributore e relative alla sezione del motore idraulico, ad un valore di pressione superiore a quello di taratura delle limitatrici di pressione della valvola. La valvola normalmente viene fornita non tarata. Campo di taratura ammissibile: da 30 a 220 bar.

Double-acting overcentre valve with shuttle valve, flangeable on AR, BR, BG motors. Usually flanged on winch driving brake motors with pressure released brake, to control load lowering and avoid unwanted acceleration. Slew drive control of cranes, aerial platforms, etcetera are common applications too. When it is employed in hoisting equipment the main relief valve or any anti-shock valve fitted on the hydraulic motor control valve section shall be set at pressure values higher than the VCR1 08 - D/AF - LDP relief valve. If not required the valve is supplied not set. Setting range between 30 and 220 bar [435 and 3190 psi].

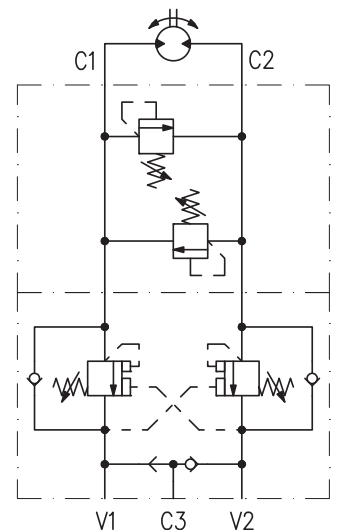
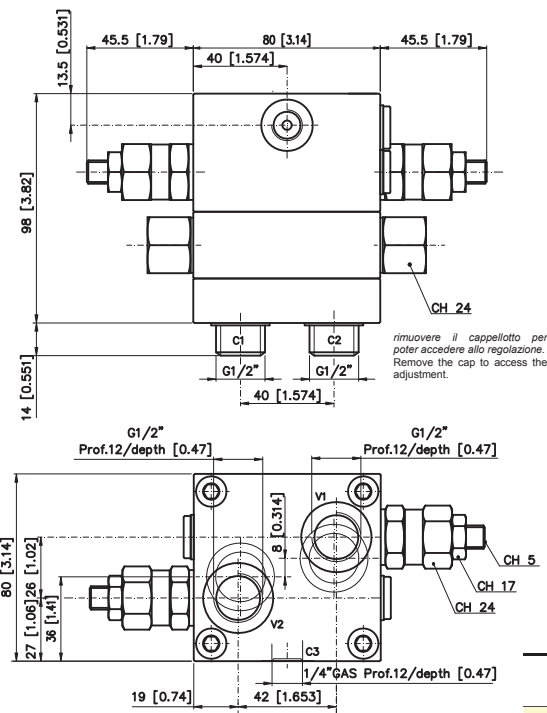

Rapporto di pilotaggio Pilot ratio	8:1 4,25:1
Pressione max esercizio Max working pressure	350 bar [5075 psi]
Portata max Max flow	60 l/min [15,8 U.S. gpm]
Peso Weight	2,5 kg [5,51 lb]

VCR1 08 - D/AF - LDP (8:1) Codice/Code: 521.2062.1017

VCR1 08 - D/AF - LDP (4.25:1) Codice/Code: 521.2060.1017

# VCR1 E8 - D/AF



Valvola di controllo bilanciata a doppio effetto, di blocco, pilotata, con selettore del fluido in pressione e flangiabile ai motori serie BR E, BG E. Assicura una frenatura progressiva ed il blocco delle masse in movimento evitando l'accelerazione incontrollata. Un opportuno dispositivo preleva il fluido in pressione, solitamente per comandare l'apertura di freni idraulici negativi. Un tipico impiego è su rotazioni di masse rilevanti (es torrette gru, piattaforme aeree, etc.). La valvola normalmente viene fornita non tarata. Campo di taratura ammissibile: da 30 a 220 bar.

Double-acting overcentre valve with shuttle valve, flangeable on BR E, BG E motors. Usually flanged on winch driving brake motors with pressure released brake, to control load lowering and avoid unwanted acceleration. Slew drive control of cranes, aerial platforms, etcetera are common applications too. If not specified the valve is supplied not set. Setting range between 30 and 220 bar [435 and 3190 psi].

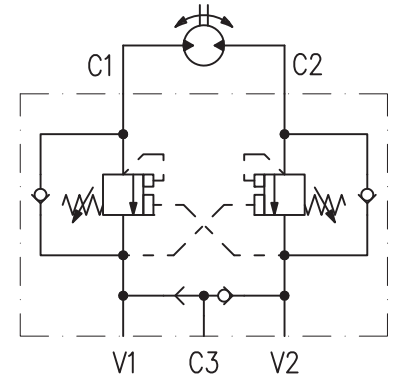
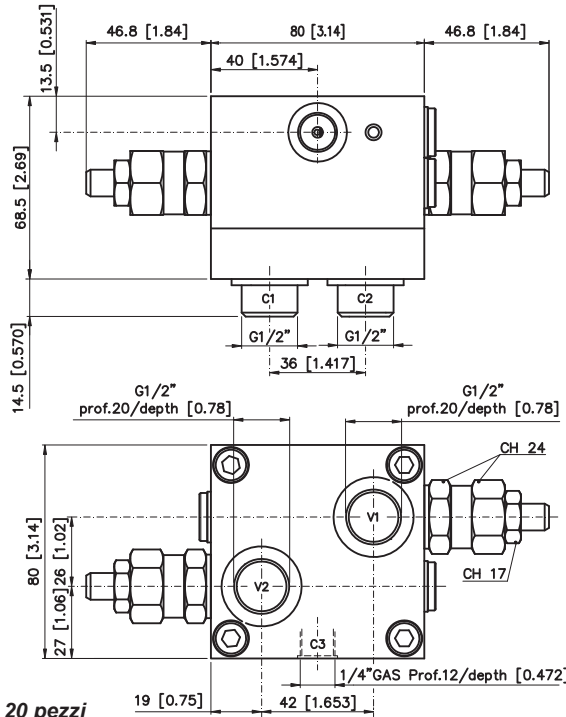

**Attenzione: quantità minima per ordine 20 pezzi**  
**Warning: minimum quantity for order 20 pieces**

VCR1 E8 - D/AF (4.25:1) Codice/Code: 521.3185.0000

Rapporto di pilotaggio Pilot ratio	4,25:1
Pressione max esercizio Max working pressure	350 bar [5075 psi]
Portata max Max flow	60 l/min [15,8 U.S. gpm]
Peso Weight	1,8 kg [3,96 lb]

# VCR1 E8 - D/AF - LDP



Valvola di controllo bilanciata a doppio effetto, di blocco, pilotata, con selettore del fluido in pressione e incorporate valvole limitatrici di pressione, flangiabile ai motori serie BR E, BG E. Assicura una frenatura progressiva ed il blocco delle masse in movimento, evitando l'accelerazione incontrollata. Un opportuno dispositivo preleva il fluido in pressione, solitamente per comandare l'apertura di freni idraulici negativi. Un tipico impiego è su rotazioni di masse rilevanti (es torrette gru, piattaforme aeree, etc.). Se utilizzata in apparecchiature per il sollevamento di carichi, è necessario tarare la valvola di massima generale dell'impianto o le valvole antiurto eventualmente presenti sul distributore e relative alla sezione del motore idraulico, ad un valore di pressione superiore a quello di taratura delle limitatrici di pressione della valvola. La valvola normalmente viene fornita non tarata. Campo di taratura ammissibile: da 30 a 220 bar.

Double-acting overcentre valve with shuttle valve, flangeable on BR E, BG E motors. Usually flanged on winch driving brake motors with pressure released brake, to control load lowering and avoid unwanted acceleration. Slew drive control of cranes, aerial platforms, etcetera are common applications too. When it is employed in hoisting equipment the main relief valve or any anti-shock valve fitted on the hydraulic motor control valve section shall be set at pressure values higher than the VCR1 E8 - D/AF - LDP relief valve. If not required the valve is supplied not set. Setting range between 30 and 220 bar [435 and 3190 psi].

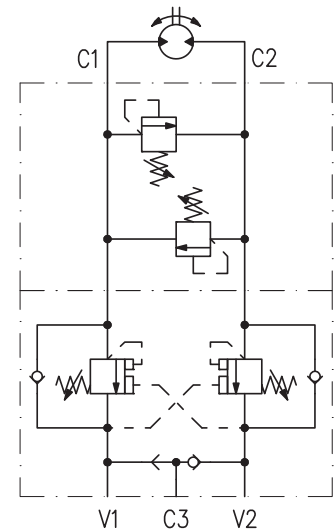
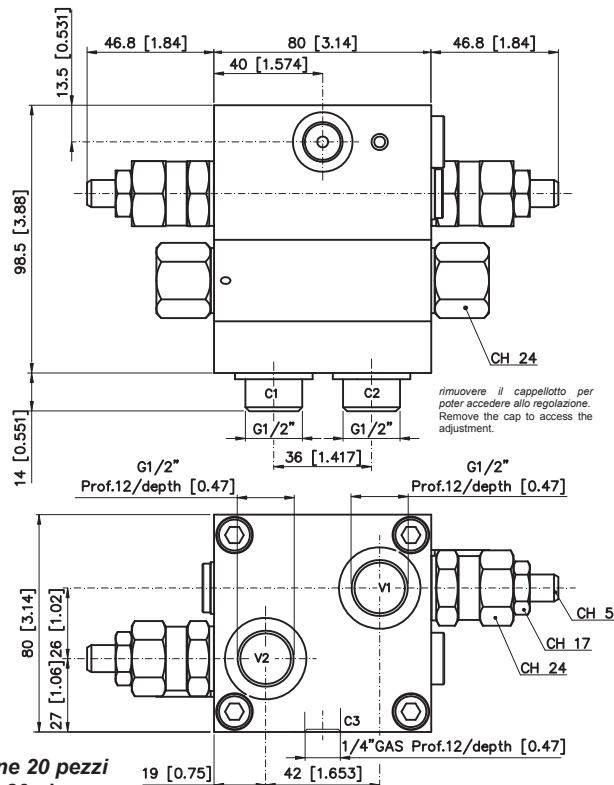

**Attenzione: quantità minima per ordine 20 pezzi**  
**Warning: minimum quantity for order 20 pieces**

VCR1 E8 - D/AF - LDP (4.25:1) Codice/Code: 521.3190.0000

Rapporto di pilotaggio Pilot ratio	4,25:1
Pressione max esercizio Max working pressure	350 bar [5075 psi]
Portata max Max flow	60 l/min [15,8 U.S. gpm]
Peso Weight	2,5 kg [5,51 lb]

# VCR1 09 - D/AF

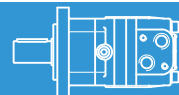

Valvola di controllo bilanciata a doppio effetto, di blocco, pilotata, con selettore del fluido in pressione e flangiabile ai motori HR. Assicura una frenatura progressiva ed il blocco delle masse in movimento evitando l'accelerazione incontrollata. Un opportuno dispositivo preleva il fluido in pressione, solitamente per comandare l'apertura di freni idraulici negativi. Un tipico impiego è su rotazioni di masse rilevanti (es torrette gru, piattaforme aeree, etc.). Su tali applicazioni è idoneo l'impiego di motori con freno incorporato versione F e L. La valvola normalmente viene fornita non tarata. Campo di taratura ammissibile: da 30 a 220 bar.

Double-acting overcentre valve with shuttle valve, flangeable on HR motors. Usually flanged on winch driving brake motors with pressure released brake, to control load lowering and avoid unwanted acceleration. Slew drive control of cranes, aerial platforms, etcetera are common applications too. For such applications versions F and L brake motors, are widely employed. If not specified the valve is supplied not set. Setting range between 30 and 220 bar [435 and 3190 psi].

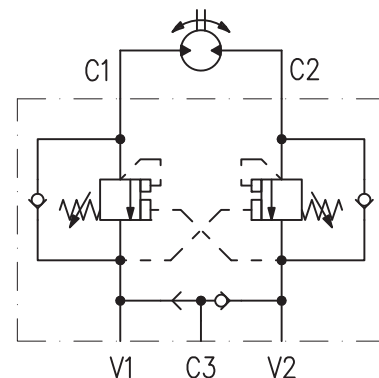
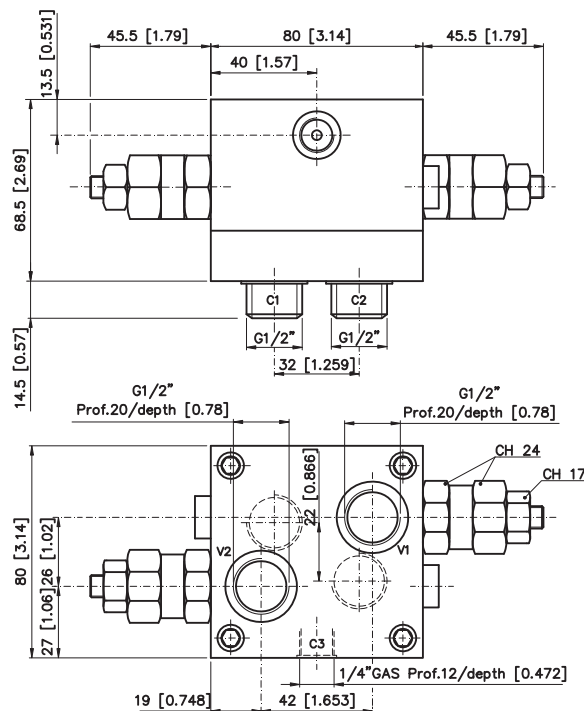

Rapporto di pilotaggio Pilot ratio	4,25:1
Pressione max esercizio Max working pressure	250 bar [3626 psi]
Portata max Max flow	60 l/min [15,8 U.S. gpm]
Peso Weight	1,8 kg [3,96 lb]

VCR1 09 - D/AF (4.25:1) Codice/Code: 521.2060.1037

# VCR1 09 - D/AF - LDP



Valvola di controllo bilanciata a doppio effetto, di blocco, pilotata, con selettore del fluido in pressione e incorporate valvole limitatrici di pressione, flangiabile ai motori HR. Assicura una frenatura progressiva ed il blocco delle masse in movimento, evitando l'accelerazione incontrollata. Un opportuno dispositivo preleva il fluido in pressione, solitamente per comandare l'apertura di freni idraulici negativi. Un tipico impiego è su rotazioni di masse rilevanti (es torrette gru, piattaforme aeree, etc.). Se utilizzata in apparecchiature per il sollevamento di carichi, è necessario tarare la valvola di massima generale dell'impianto o le valvole antiurto eventualmente presenti sul distributore e relative alla sezione del motore idraulico, ad un valore di pressione superiore a quello di taratura delle limitatrici di pressione della valvola. La valvola normalmente viene fornita non tarata. Campo di taratura ammissibile: da 30 a 220 bar.

Double-acting overcentre valve with shuttle valve, flangeable on HR motors. Usually flanged on winch driving brake motors with pressure released brake, to control load lowering and avoid unwanted acceleration. Slew drive control of cranes, aerial platforms, etcetera are common applications too. When it is employed in hoisting equipment, the main relief valve or any anti-shock valve fitted on the hydraulic-motor control valve section shall be set at pressure values higher than the VCR1 09-D/AF-LDP relief valve. If not required the valve is supplied not set. Setting range between 30 and 220 bar [435 and 3190 psi].

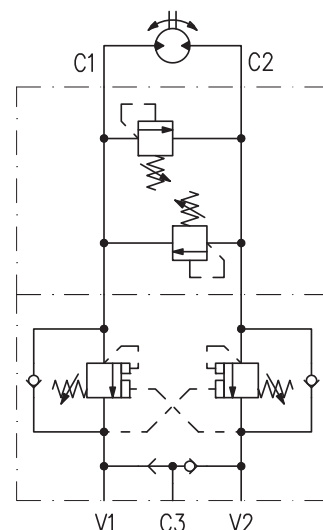
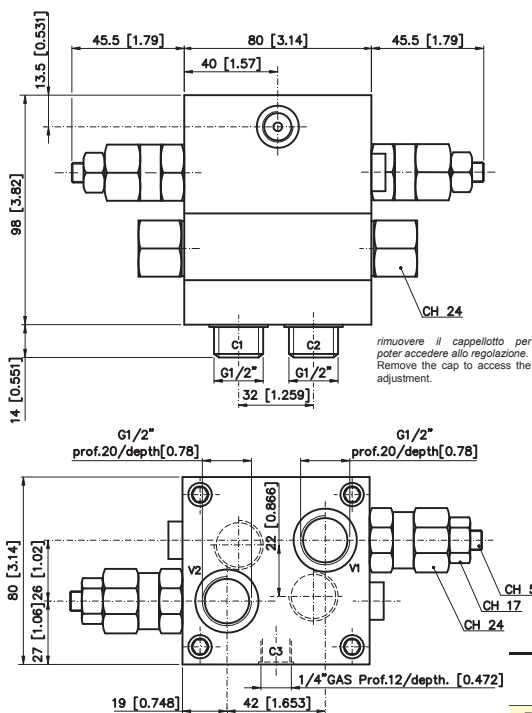

Rapporto di pilotaggio Pilot ratio	4,25:1
Pressione max esercizio Max working pressure	250 bar [3626 psi]
Portata max Max flow	60 l/min [15,8 U.S. gpm]
Peso Weight	2,5 kg [5,51 lb]

VCR1 09 - D/AF - LDP (4.25:1) Codice/Code: 521.2060.1047



# VAF 10 - D

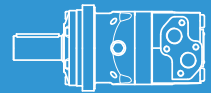

Valvola di massima pressione doppia, flangiabile ai motori idraulici serie HT - HTC. Protegge il motore da eccessivi valori di pressione, in particolare nelle fasi di avvio, arresto ed inversione del moto. Il campo di taratura standard è da 100 a 200 bar. È disponibile anche la versione speciale da 210 a 300 bar. La valvola normalmente viene fornita non tarata. È possibile la fornitura della valvola già tarata, in tal caso precisare al momento dell'ordine: valore di taratura e relativa portata.

Pressure relief valve flangeable on HT - HTC series motors which protects the motor from excessive peak of pressure particularly at start, stop and inversion. If not requested, valves are supplied not set. Any setting requirement must be specified at ordering by stating pressure and flow. Two setting ranges are available: 100 to 200 bar [1450 to 2900 psi] as standard and 210 to 300 bar [3045 to 4350 psi] as optional.

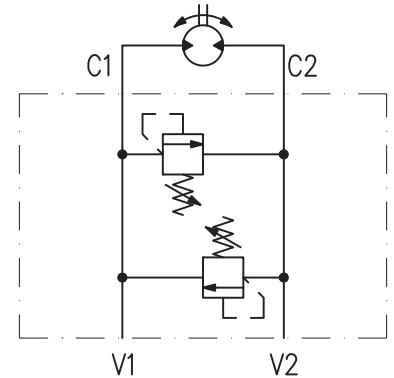
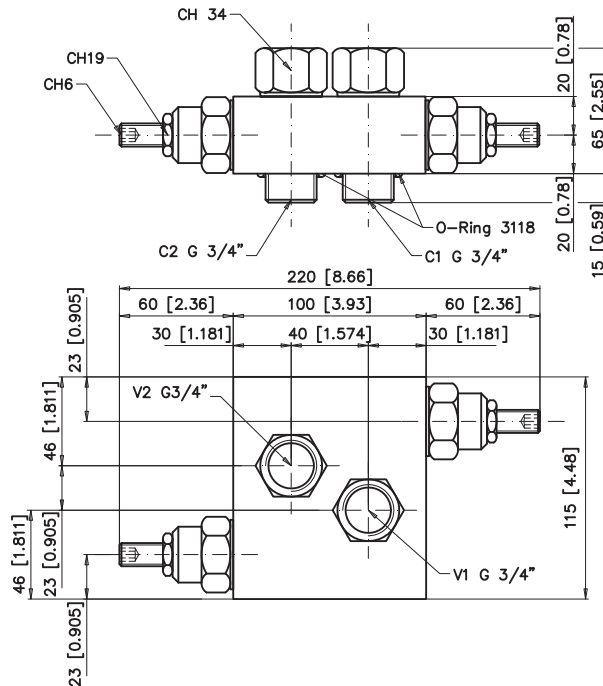

VAF 10 - D (100÷200 bar / 1450÷2900 psi) Codice/Code: 521.2080.0100 (Standard)  
 VAF 10 - D (210÷300 bar / 3045÷4350 psi) Codice/Code: 521.2080.0101

Pressione max esercizio Max working pressure	<b>250 bar</b> <b>[3625 psi]</b>
Portata max Max flow	<b>100 l/min</b> <b>[26,4 U.S. gpm]</b>
Peso Weight	<b>1,5 kg</b> <b>[3,30 lb]</b>

# VCD2 10 - S/AF



Valvola bilanciata di blocco e controllo discesa con selettore del fluido in pressione, singola pilotata e flangiabile ai motori HT e HTC. Normalmente è impiegata per controllare la discesa del carico in argani con freno idraulico negativo a sbloccaggio oleodinamico evitandone l'accelerazione incontrollata. La valvola normalmente viene fornita non tarata. Campo di taratura standard: da 100 a 350 bar. Speciale a richiesta: da 30 a 210 bar.

Single acting overcentre valve with shuttle valve flangeable on HT and HTC motors, usually flanged on which with pressure released brake to control load lowering and avoid unwanted acceleration. If not specified the valve is supplied not set. Available setting range: standard between 100 and 350 bar [1450 and 5075 psi]. Optional: between 30 and 210 bar [435 and 3045 psi].

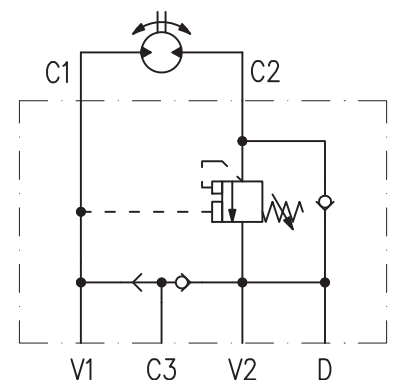
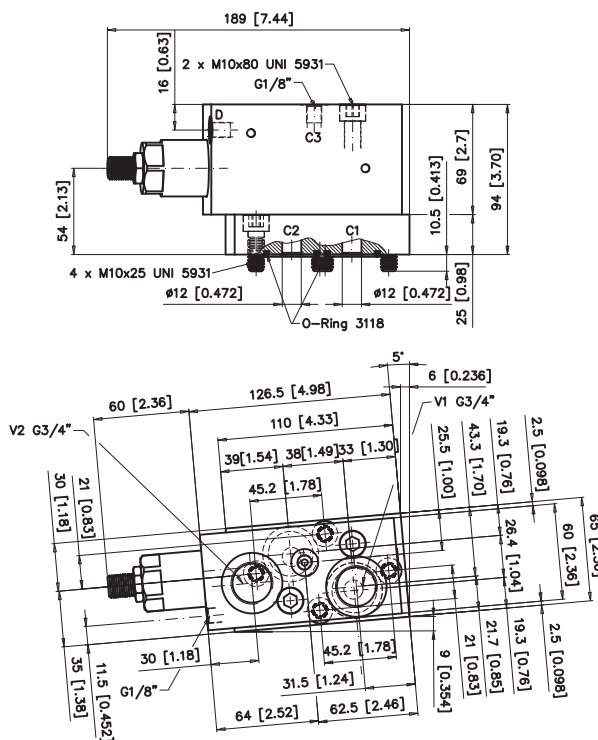

VCD2 - 10 S/AF (100÷350 bar / 1450÷5075 psi) Codice/Code: SPO00000192 (Standard)  
 VCD2 - 10 S/AF (30÷210 bar / 435÷3045 psi) Codice/Code: SPO00000193

Rapporto di pilotaggio Pilot ratio	<b>7:1</b>
Pressione max esercizio Max working pressure	<b>350 bar</b> <b>[5075 psi]</b>
Portata max Max flow	<b>100 l/min</b> <b>[26,4 U.S. gpm]</b>
Peso Weight	<b>2,05 kg</b> <b>[4,51 lb]</b>

# VCR1 10 - D/AF



Valvola di controllo bilanciata a doppio effetto, di blocco, pilota, con selettore del fluido in pressione e flangiabile ai motori serie HT e HTC. Assicura una frenata progressiva ed il blocco delle masse in movimento evitando l'accelerazione incontrollata. Un opportuno dispositivo preleva il fluido in pressione, solitamente per comandare l'apertura di freni idraulici negativi. Un tipico impiego è su rotazioni di masse rilevanti (es. torrette, gru, piattaforme aeree, etc.). La valvola normalmente viene fornita non tarata. Campo di taratura ammissibile da 100 a 350 bar.

Double-acting overcentre valve with shuttle valve, flangeable on HT and HTC motors. Usually flanged on winch with pressure released brake, to control load lowering and avoid unwanted acceleration. Slew drive control of cranes, aerial platforms, etcetera are common applications too. If not specified the valve is supplied not set. Setting range between 100 and 350 bar [1450 and 5075 psi].

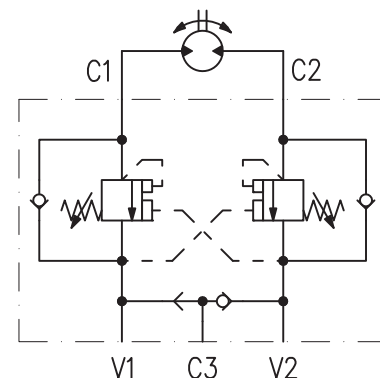
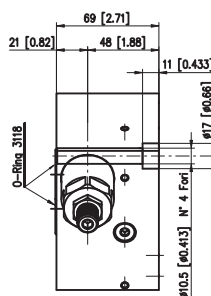
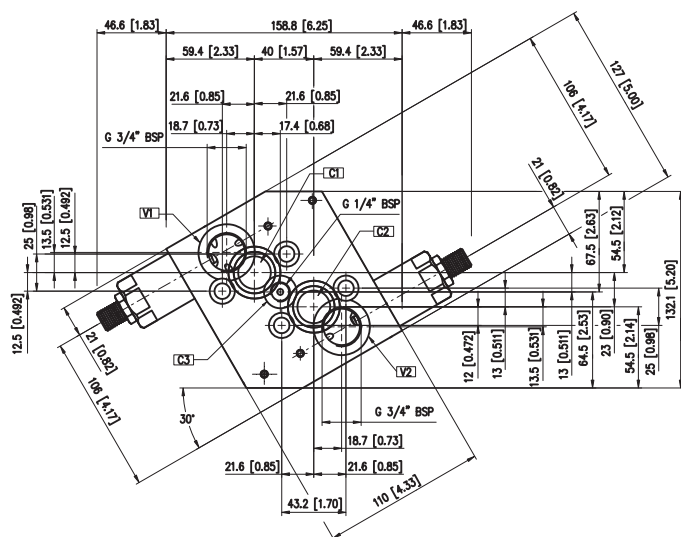

VCR1 - 10 D/AF (7:1) Codice/Code: SPO00000212  
 VCR1 - 10 D/AF (10:1) Codice/Code: SPO00000189

Rapporto di pilotaggio Pilot ratio	10:1 7:1
Pressione max esercizio Max working pressure	250 bar [3625 psi]
Portata max Max flow	100 l/min [26,4 U.S. gpm]
Peso Weight	2,0 kg [4,40 lb]

# VSC



Valvola di scambio flangiabile su motori HR e HT per trasmissioni idrostatiche in circuito chiuso. Permette il raffreddamento dell'olio, di solito necessario quando si è in presenza di elevate velocità di esercizio ed elevate potenze. La valvola si compone di un distributore a tre posizioni e tre vie che preleva olio dalla linea a bassa pressione del circuito e lo invia alla carcassa del motore e da qui al serbatoio. Per un corretto funzionamento è necessario collegare il drenaggio del motore al serbatoio. La valvola può essere montata solo con l'utilizzo di un coperchio dedicato (vedi catalogo motori).

Flushing valve for HR and HT motors used in closed circuit hydrostatic transmissions. Allows an oil cooling action, which is recommended when operating at high speed and power. The unit is made by a three positions - three way spool valve that allows a small oil flow from the low pressure line of the circuit into the motor casing, then into the tank. For a correct operation it is necessary to connect the drain port of the motor with the tank. The valve can be mounted only with a dedicated cover on the motor (see motor catalogue).

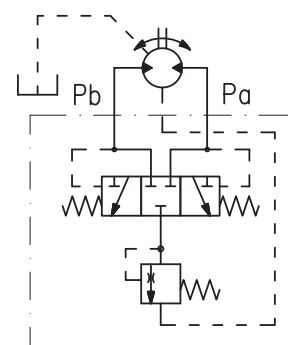
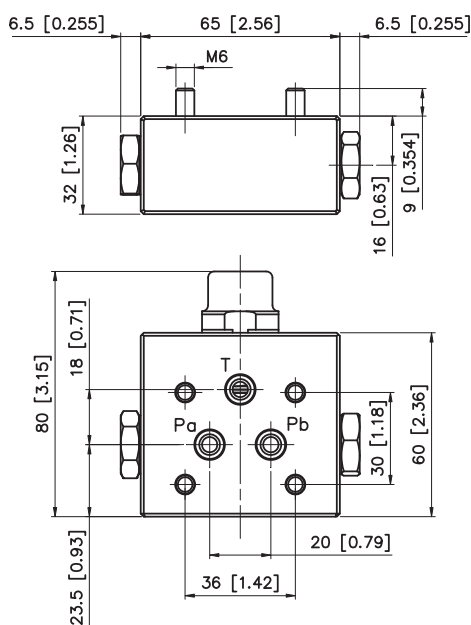

La valvola di scambio può essere fornita nelle seguenti versioni:  
 The shuttle valve can be fitted in the following versions:

Codice Code	Descrizione Description	Portata Teorica (22 bar) Theoretical flow [319 psi]	Diametro strozzatore Orifice Diameter
521.5200.0000	VALVOLA VSC 06F VSC 06F VALVE	6 l/min [1.5 U.S. gpm]	1.5 mm [0.05 in]
521.5210.0000	VALVOLA VSC 09F VSC 09F VALVE	10.5 l/min [2.7 U.S. gpm]	2 mm [0.07 in]
521.5220.0000	VALVOLA VSC 15F VSC 15F VALVE	15 l/min [3.9 U.S. gpm]	2.5 mm [0.09 in]
521.5230.0000	VALVOLA VSC 21F VSC 21F VALVE	20 l/min [5.2 U.S. gpm]	3.3 mm [0.12 in]

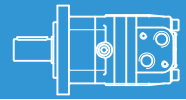

Questa valvola flangiabile ai motori HR permettono il controllo della portata mediante una strozzatura non compensata. L'azione di strozzamento avviene in una sola direzione, la regolazione e' possibile ruotando a destra o a sinistra la vite o il volantino. Sono costruite completamente in acciaio e protette esternamente mediante zincatura tropicalizzata. Garantiscono un'ottima tenuta meccanica con trafilamento trascurabile.

The valve flangeable on HR motor series permit the flow control by the means of a non-compensated throttle valve. The control is possible in one direction only and the regulation is obtained by turning to the left or right the screw or the hand wheel. The valves are made completely in steel and are protected on surface by tropicalized zinc plating. A high degree of mechanical sealing is ensured along with negligible leakage.

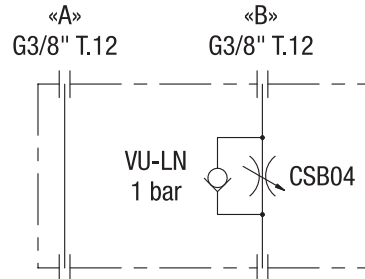
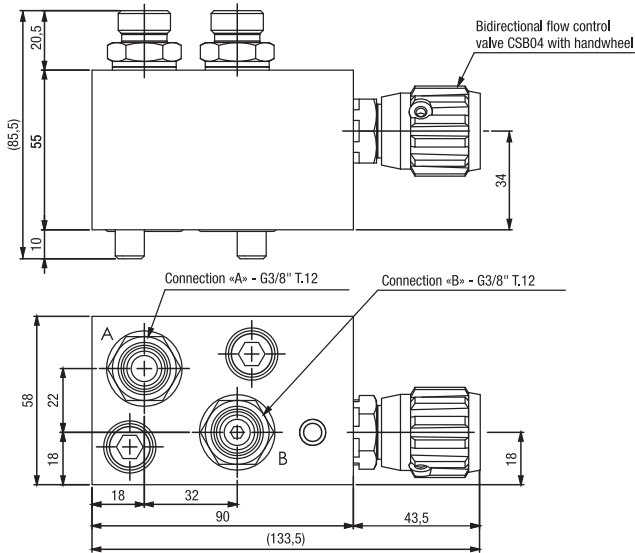

VRP 09 Codice/Code: P15111618

Pressione max esercizio Max working pressure	<b>315 bar</b> [4567 psi]
Portata max Max flow	<b>40 l/min</b> [10.5 U.S. gpm]
Peso Weight	<b>2,1 kg</b> [4,62 lb]

## SCelta DEL CORREtto RAPPORTo DI PILOTAGGIO PER LE VALVole OvERCENTRE HOW TO SELECT THE BEST PILOT RATIO FOR OVERCENTRE VALVES

Valori più alti del rapporto di pilotaggio garantiscono una minore perdita di energia nelle fasi di discesa del carico (o di controllo di carichi negativi). Viceversa, valori bassi del rapporto di pilotaggio garantiscono un più stabile controllo di carichi variabili, con una maggiore dissipazione di energia durante la discesa.

Qualora vengano impiegati motori con freno, sono preferibili rapporti di pilotaggio più bassi, in quanto garantiscono una pressione più elevata per lo sblocco del freno quando il motore è trascinato dal carico: in tal modo il freno risulta certamente sbloccato nelle fasi di discesa. La pressione di pilotaggio deve essere superiore (anche durante la discesa del carico massimo) alla pressione di completa apertura del freno, per evitare interferenze fra freno e valvola.

**Attenzione:** Per un corretto funzionamento, le valvole di controllo discesa e controllo rotazione (VCR1-VCD) devono essere tarate ad un valore di pressione superiore del 30% (almeno) al valore di pressione massima prodotta dal carico ed utilizzate con distributori a centro aperto.

High pilot ratios ensure small energy losses during load lowering (or any time the motor is driven by load), while low pilot ratios ensure a better control of variable intensity loads, but with a higher energy loss during lowering.

For brake motors we recommend low pilot ratios: they ensure a higher brake disengagement pressure when the motor is driven by the load, in order to have the brake completely disengaged during load lowering.

The minimum pilot pressure must be higher (even during load lowering) than the full disengagement pressure, to avoid interferences between brake and valve.

**Warning:** The overcentre and slewing control valves (VCR1 - VCD) have to be set at pressure values 30% higher (at least) than the nominal pressure induced by the load and must be used with open centre directional valves.



Base per assemblaggio su motori serie AR, BR, BG predisposti per BFL 1.

Base Block for AR, BR, BG motors with BFL 1 configuration.

Codice/Code: 109.0100.9000

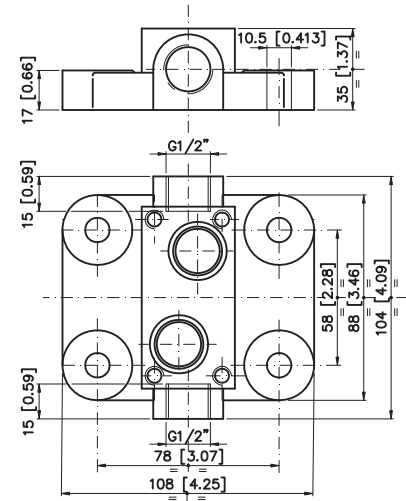

**BOCCOLE  
BUSHINGS**

**SERIE  
SERIES**

**BS - BSD**

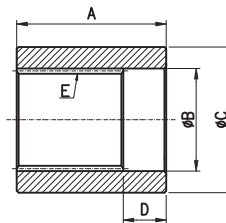

Tipo - Type	Dimensioni - Dimensions						
		A	B	C	D	E	COD.
BS 16/P	mm [in]	27 [1.06]	-	24 [0.94]	-	17x14 DIN 5482	320.0070.0000
BS 25/P	mm [in]	43 [1.69]	25,3 [0.99]	40 [1.57]	9 [0.354]	25X22 DIN 5482	320.0130.0000
BSD 25/P	mm [in]	37 [1.45]	25,7 [1.01]	40 [1.57]	9 [0.354]	SAE 1"6 B	320.0210.0000
BS 32/P	mm [in]	48 [1.88]	32 [1.25]	50 [1.96]	10 [0.393]	ANSI B92.1a - 1976	320.0090.0000

**BOCCOLE  
BUSHINGS**

**SERIE  
SERIES**

**BS - FBS**

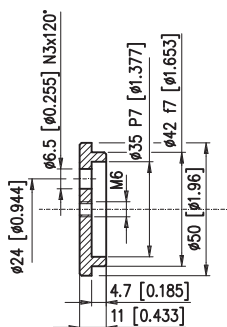

FBS 12 cod. 319.0050.0000

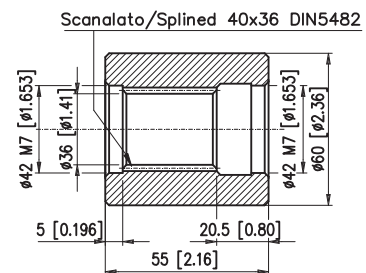

BS 12 cod. 320.0150.0000

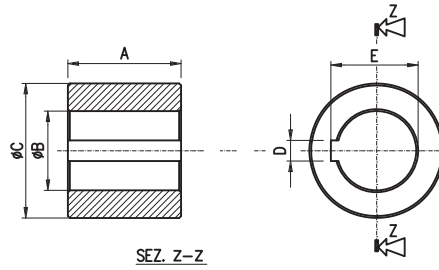

Tipo - Type	Dimensioni - Dimensions						
		A	B	C	D	E	COD.
<b>BC 25/P</b>	mm [in]	43 [1.69]	25 [0.98]	40 [1.57]	8 [0.314]	28,3 [1.11]	320.0110.0000
<b>BC 25,4/P</b>	mm [in]	43 [1.69]	25,4 [1.00]	40 [1.57]	6,35 [0.25]	28,3 [1,11]	320.0050.0000
<b>BC 32/P</b>	mm [in]	50,5 [1.98]	32 [1.25]	50 [1.96]	10 [0.393]	35,3 [1.38]	320.0280.0000





**BREVINI<sup>®</sup>**

*Motion Systems*

Code DOC00074 - Rev. 04

**Dana Brevini S.p.A.**

Via Luciano Brevini 1/a

42124 Reggio Emilia

Tel. +39 0522 270711

Fax +39 0522 270660

[www.dana.com/brevini](http://www.dana.com/brevini)

[info@brevinifluidpower.com](mailto:info@brevinifluidpower.com)

