



MSD

DIRECT OPERATED SEQUENCE VALVE

SERIES 50

MODULAR VERSION ISO 4401-03

p max 350 bar
Q max (see table of performances)

MOUNTING INTERFACE

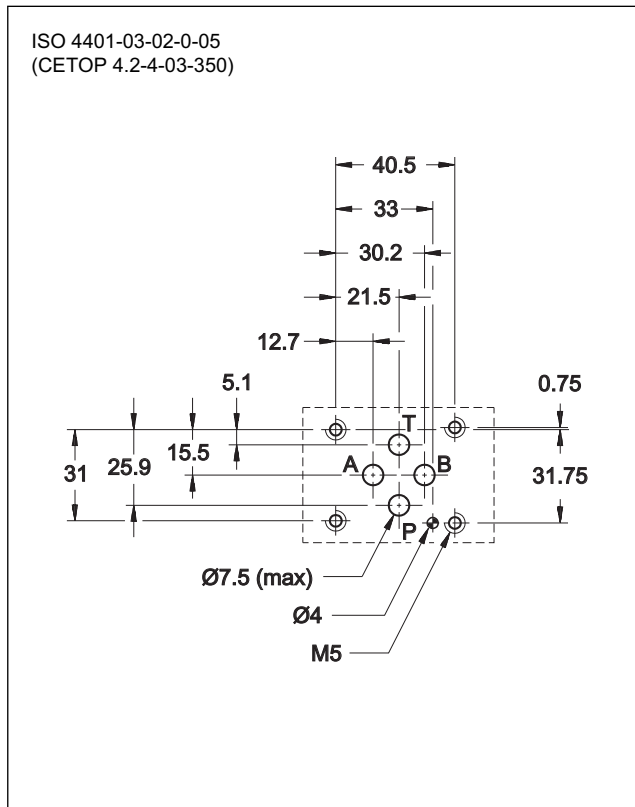

OPERATING PRINCIPLE

- The MSD valve is a direct operated sequence valve of the spool type and is used to control two or more actuators in succession.
- At rest position, it is normally closed and the spool is subject to pressure in line P1 on one side and to the adjustment screw on the other side. When the pressure in line P1 reaches the set value of the screw, the valve opens and allows passage of the fluid in the pressure line of the main circuit.
- The valve stays open until the pressure in the circuit drops below the calibrated value set by the spring.
- It is made as a modular version with ports according to the ISO 4401 standards and can be assembled quickly without the use of pipes under the ISO 4401-03 directional solenoid valves.
- It is normally supplied with a hexagonal head adjustment screw. Upon request, it can be equipped with a SICBLOC adjustment knob with micrometric indication and automatic locking.

PERFORMANCES (measured with mineral oil of viscosity 36cSt at 50°C)

Maximum operating pressure maximum pressure on port T	bar	350 10
Maximum flow rate in the controlled lines Maximum flow rate in the free lines	l/min	50 75
Ambient temperature range	°C	-20 / +60
Fluid temperature range	°C	-20 / +80
Fluid viscosity range	cSt	10 ÷ 400
Fluid contamination degree	According to ISO 4406:1999 class 20/18/15	
Recommended viscosity	cSt	25
Mass	kg	1,4

HYDRAULIC SYMBOLS

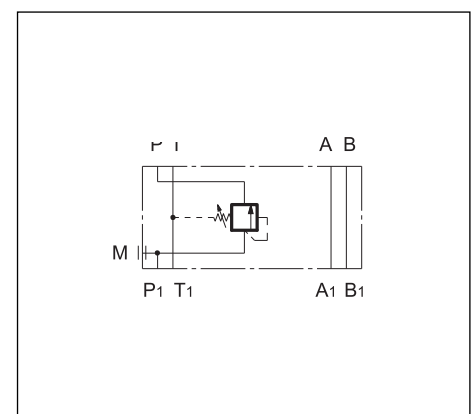

1 - IDENTIFICATION CODE

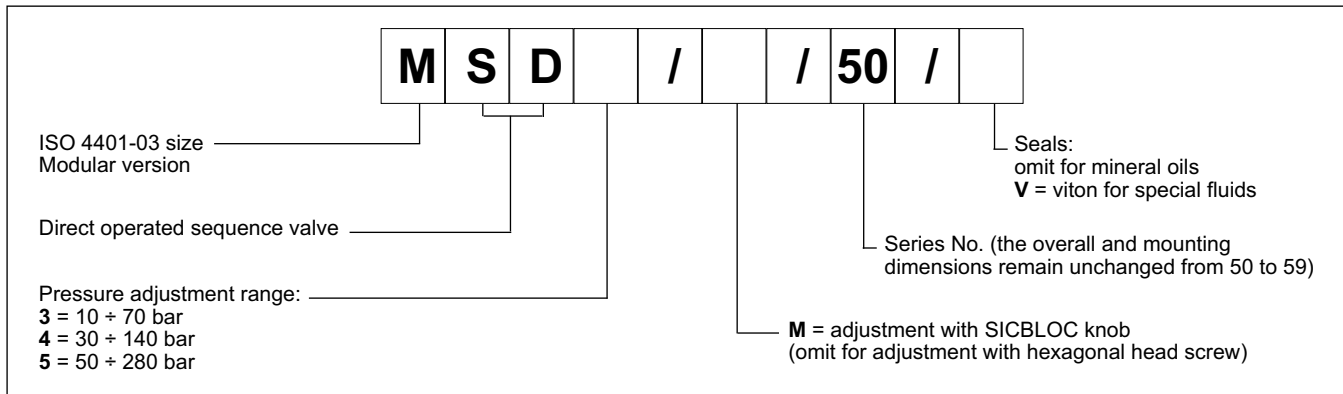

2 - CHARACTERISTIC CURVES (values obtained with viscosity of 36 cSt at 50°C)

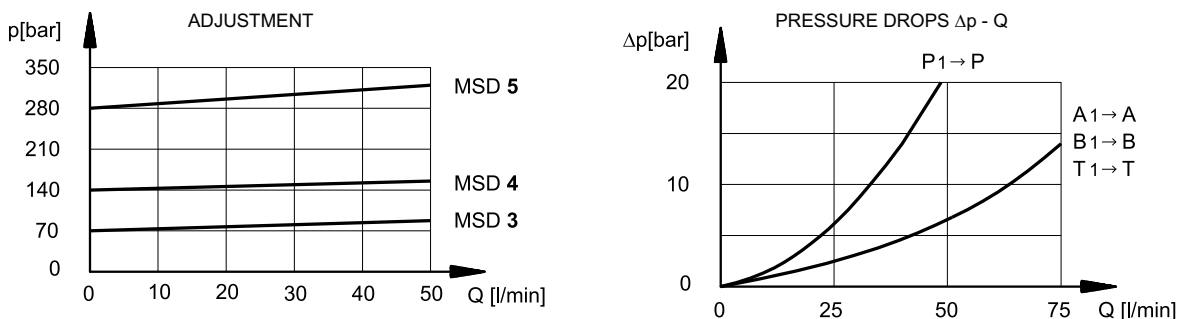

3 - HYDRAULIC FLUIDS

Use mineral oil-based hydraulic fluids HL or HM type, according to ISO 6743-4. For these fluids, use NBR seals. For fluids HFDR type (phosphate esters) use FPM seals (code V). For the use of other kinds of fluid such as HFA, HFB, HFC, please consult our technical department.

Using fluids at temperatures higher than 80 °C causes a faster degradation of the fluid and of the seals characteristics. The fluid must be preserved in its physical and chemical characteristics.

4 - OVERALL AND MOUNTING DIMENSIONS

