

MOTORE "Z-J HYDRAULIC"
"Z-J HYDRAULIC" MOTOR
MOTOR "Z-J HYDRAULIC"

ALBERO CILINDRICO Ø25
PARALLEL SHAFT Ø25
ZYLINDRISCHE WELLE Ø25

FLANGIA "SAE A" - 2 FORI
"SAE A" FLANGE - 2 HOLES
FLANSCH "SAE A" - 2 BOHRUNGEN



MCRN

Standard: CON CUSCINETTI A RULLI PER CARICHI RADIALI - WITH NEEDLE BEARINGS FOR RADIAL LOADS - MIT ROLLENLAGERN FÜR RADIALE BELASTUNG

VALVOLE UNIDIREZIONALI INCORPORATE
BUILT-IN CHECK VALVES
EINGEBAUTE RÜCKSCHLAGVENTILE

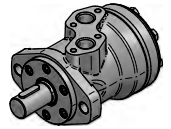
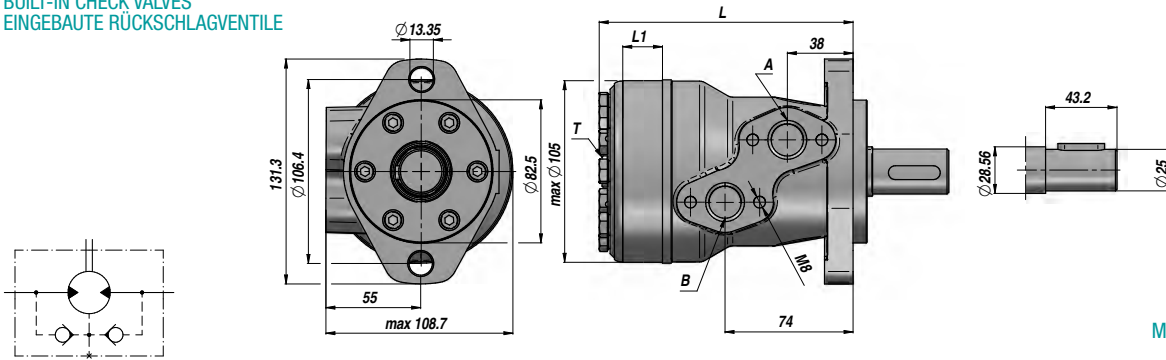

VERNICIATO NERO
BLACK PAINTED
SCHWARZ GRUNDIERT

PREDISPOSTO PER IL DRENAGGIO
MACHINED FOR DRAIN CONNECTION
FÜR DRÄNLEITUNG GEEIGNET

Codice Code Bestell-Nr.	Tipo Type Typ	cm ³ /giro cm ³ /rev cm ³ /U	n. Max giri/min rpm - U/Min.	M Max daNm	Q MAX l/min	P MAX bar			A - B	T	L	L1	kg
						Caduta Drop Gefälle Δp	Ingresso Inlet Eingang	Ritorno Return Rücklauf					
LAVORO CONTINUO - CONTINUOUS WORK - DAUERARBEIT													
MCRN036CDO	MC-RN 36 CD	36.0	1085	7.2	40	140	175	175 *			137	7.0	6.50
MCRN050CDO	MC-RN 50 CD	51.7	960	10,0	50	140	175	175 *			140	10,0	6.70
MCRN080CDO	MC-RN 80 CD	81.5	750	19,5	60	175	175	175 *			146	16,0	6.90
MCRN100CDO	MC-RN 100 CD	102,0	600	24,0	60	175	175	175 *			150	20,0	6.90
MCRN125CDO	MC-RN 125 CD	127,2	475	30,0	60	175	175	175 *	1/2"	1/4"	155	25,0	7.20
MCRN160CDO	MC-RN 160 CD	157,2	378	36,0	60	165	175	175 *			161.5	30,5	7.50
MCRN200CDO	MC-RN 200 CD	194,5	310	36,0	60	130	175	175 *			170	38,1	8.00
MCRN250CDO	MC-RN 250 CD	253,3	240	39,0	60	110	175	175 *			180	50,0	8.50
MCRN315CDO	MC-RN 315 CD	317,5	190	39,0	60	90	175	175 *			192	62,0	9.00
MCRN400CDO	MC-RN 400 CD	381,4	155	36,5	60	70	175	175 *			204	74,0	9.30

* = CON DRENAGGIO - WITH DRAIN - MIT DRÄNLEITUNG

**PRESSIONE MAX. AL RITORNO SENZA DRENAGGIO
MAX. RETURN PRESSURE WITHOUT DRAIN
MAX GEGENDRUCK OHNE DRÄNLEITUNG**

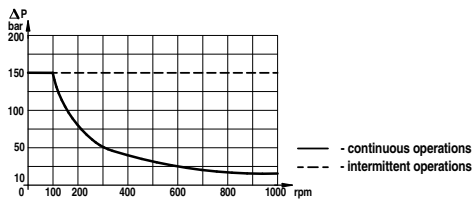

**CARICHI AMMESSI SULL'ALBERO
PERMISSIBLE SHAFT LOADS
ZULÄSSIGE WELLENBELASTUNGEN**

