

Technical features

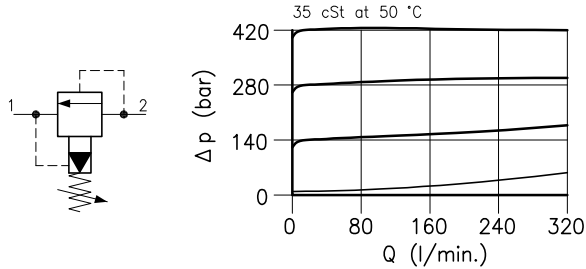

Cavity	(For dimensions see catalogue 17.000)	S 70/2
Max. flow	(l/min.)	320
Max. inlet pressure	(bar)	420
Max. pressure on line 1	(bar)	210
Fluid viscosity range	(cSt)	2.8 - 380
Fluid temperature range	(°C)	-20 +80
Max. leakage	(cm ³ /min.)	50
Mass	(kg)	0.550
Cracking pressure 95% of setting value		
Reseat pressure 85% of setting value		
Cracking pressure defined with 1 l/min.		
Standard setting obtained with 10 l/min.		
Hydraulic fluid; mineral oil HM and HV ISO 6074		
Recommended filtration; 19/15 ISO 4466 (25 μ absolutes)		
Standard seals in Polyurethane and Buna N		

Dimensions

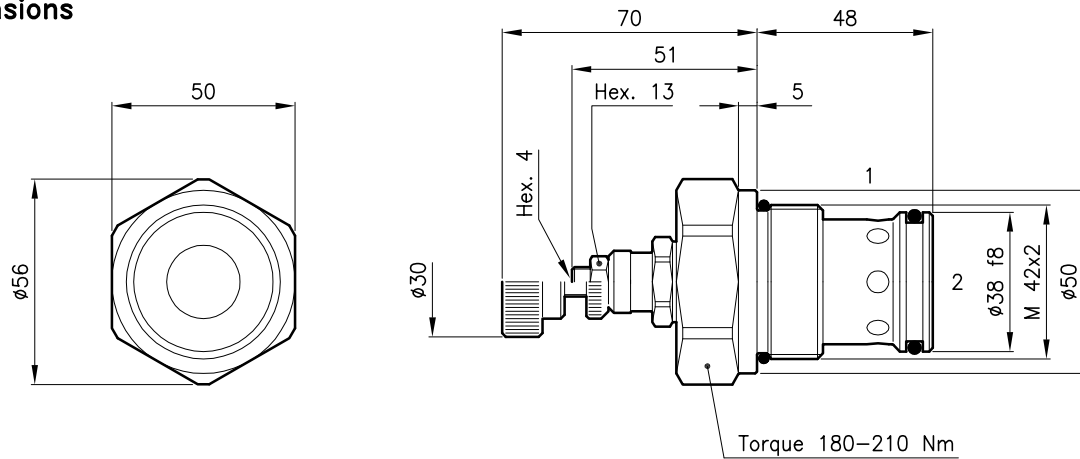

Ordering informations

LPI 70 = Valve type **LPI 70/D-N**

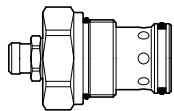

Standard springs

Type	Setting range	Factory set
D	= 14 - 210 bar	140 bar
Q	= 105 - 420 bar	315 bar

Adjustment type

- N** = Standard adjustment
- V** = Handknob adjustment

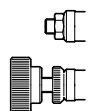

Codes:

LPI 70/D-N	71 011 100
LPI 70/Q-N	71 011 103
LPI 70/D-V	71 011 104
LPI 70/Q-V	71 011 105
External seals kit	90 620 109

LPI 70 valves can be assembled on standard bodies 70-LO series; for dimensions see catalogue 16.010