

246
300
307

641
175
340

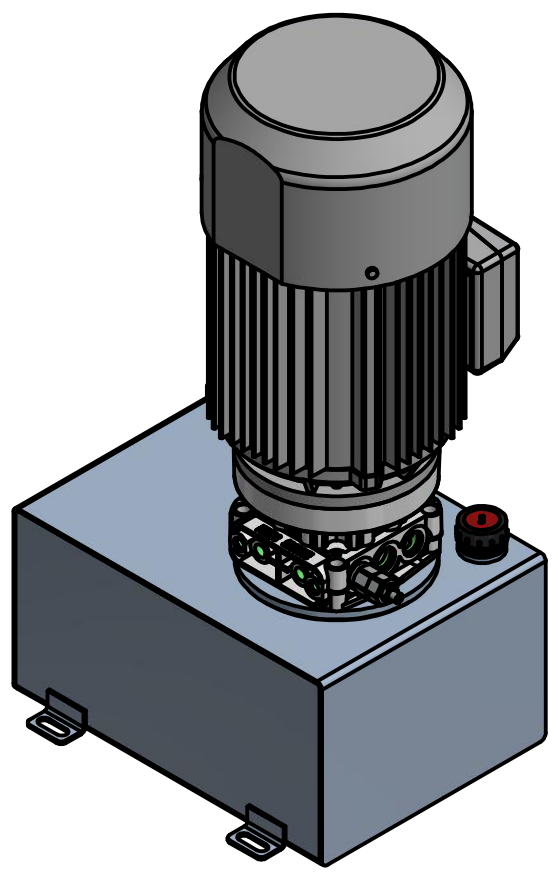

Format: A3 Scale: 0,17 : 1

Date: 05.10.2020	Designer: Boris Andrisek	Revision:
Our ref.:	Customer number.:	Order number.:

EGIL ENG & CO. AS
VÅR KUNNSKAP - DIN TRYGGHET

Title:
Power Pack
7,0 l/min 190bar 13L 2,20kW
Egil eng AS/miniagregat

Drawing number:
HO0500230V02213GA

Approved: Comment:

DENNE TEGNING TILHØRER EGIL ENG & CO AS. KOPIERING ER IKKE TILLATT. ALLE RETTIGHETER I.H.T. GJELDENE LØVER. PROPERTY OF EGIL ENG & CO AS. REPRODUCTION NOT PERMITTED. DIESE ZEICHNUNG IST EIGENTUM DER FIRMA EGIL ENG & CO AS. NICHT GENEHMIGTE VERVIELFÄLTIGUNG SIND UNZULÄS SIG.