

Technical features

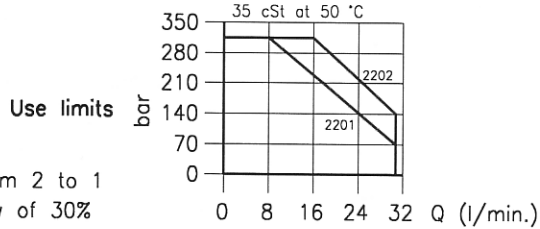
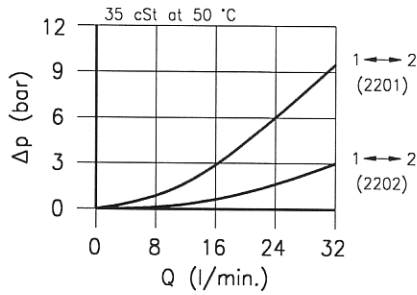
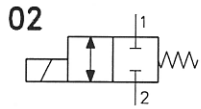
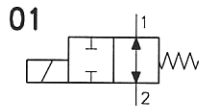

With flow from 2 to 1
limit the flow of 30%

Cavity	(For dimensions see catalogue 17.000)	S 30/2
Max. flow	(With flow from 1 to 2) (l/min.)	30
Max. pressure	(bar)	315
Max. leakage	(cm ³ /min.)	25
Response time	(ms)	30 - 60
It change in function of circuit, pressure, flow and fluid viscosity.		(Mean value)
Fluid viscosity range	(cSt)	2.8 - 380
Fluid temperature range	(°C)	-20 +80
Mass	(kg)	0.210
Hydraulic fluid; mineral oil HM and HV ISO 6074		
Recommended filtration; 19/15 ISO 4466 (25 μ absolutes)		
Standard seals in Polyurethane and Buna N		

Dimensions

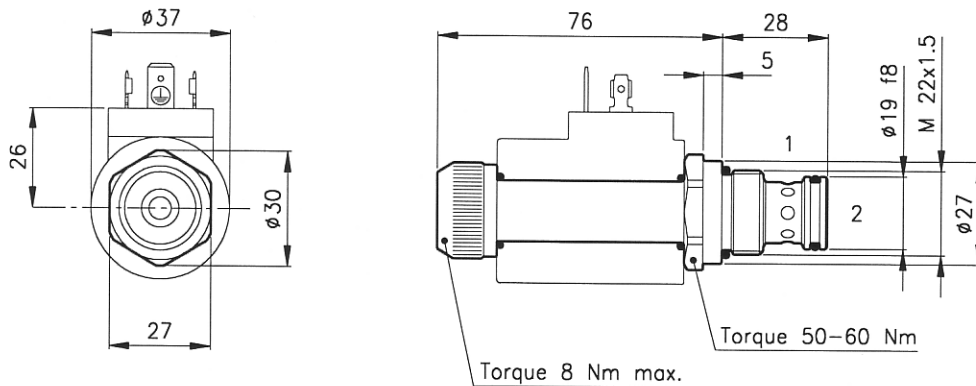

Ordering informations

ETD 30/2201

ETD 30/22.. = Valve type

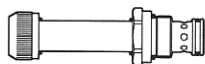

Circuits

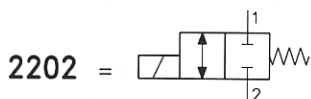
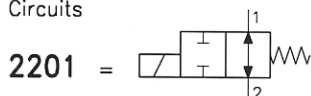

Codes:

ETD 30/2201	35 011 120
ETD 30/2202	35 011 130
External seals kit	90 620 103

ETD 30/22.. valves can be assembled on standard bodies 30-L0 series; for dimensions see catalogue 16.010

On the ETD 30 valves must be assembled the Coils B30 series; for dimensions, features and codes see catalogues 09.900 and 09.901.