

Technical features

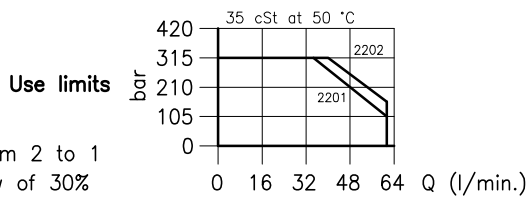

Cavity	(For dimensions see catalogue 17.000)	S 50/2
Max. flow	(With flow from 1 to 2) (l/min.)	60
Max. pressure	(bar)	315
Max. leakage	(cm ³ /min.)	40
Response time	(ms)	40 - 80 <small>(Mean value)</small>
<small>It change in function of circuit, pressure, flow and fluid viscosity.</small>		
Fluid viscosity range	(cSt)	2.8 - 380
Fluid temperature range	(°C)	-20 +80
Mass	(kg)	0.400
Hydraulic fluid; mineral oil HM and HV ISO 6074		
Recommended filtration; 19/15 ISO 4466 (25 μ absolutes)		
Standard seals in Polyurethane and Buna N		

Dimensions

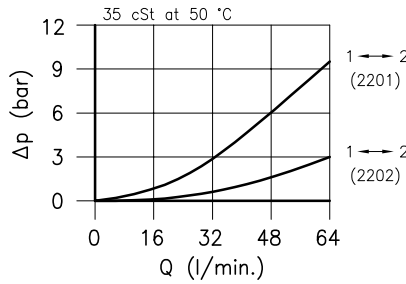
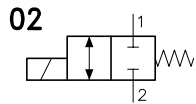
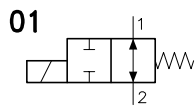
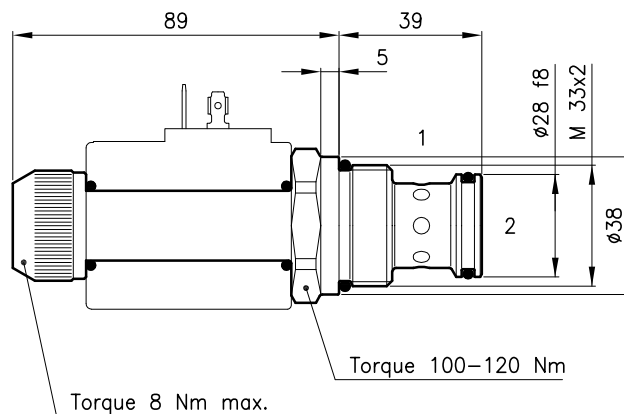
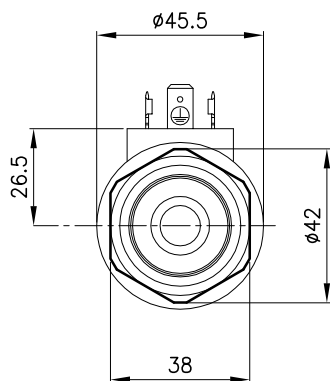

Ordering informations

ETD 50/2201

ETD 50/22.. = Valve type

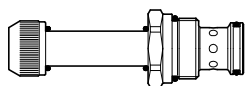

Circuits

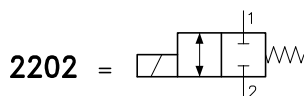
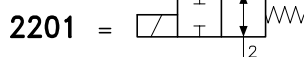

Codes:

ETD 50/2201	55 011 111
ETD 50/2202	55 011 115
External seals kit	90 620 106

ETD 50/22.. valves can be assembled on standard bodies 50-L0 series; for dimensions see catalogue 16.010

On the ETD 50 valves must be assembled the Coils B50 series; for dimensions, features and codes see catalogues 09.900 and 09.901.