

Technical features

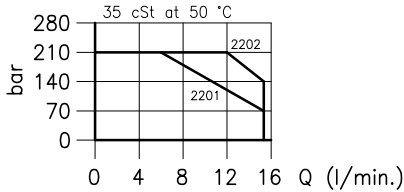
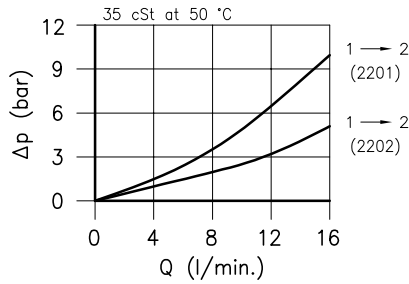
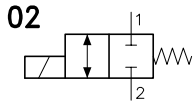
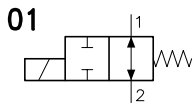

Use limits

With flow from 2 to 1
limit the flow of 30%

Cavity (For dimensions see catalogue 17.000)	S 20/2
Max. flow (With flow from 1 to 2) (l/min.)	15
Max. pressure (bar)	210
Max. leakage (cm ³ /min.)	20
Response time (ms) <small>It change in function of circuit, pressure, flow and fluid viscosity.</small>	20 - 40 (Mean value)
Fluid viscosity range (cSt)	2.8 - 380
Fluid temperature range (°C)	-20 +80
Mass (kg)	0.120
Hydraulic flow; mineral oil HM and HV ISO 6074	
Recommended filtration; 19/15 ISO 4466 (25 μ absolutes)	
Standard seals in Polyurethane and Buna N	

Dimensions

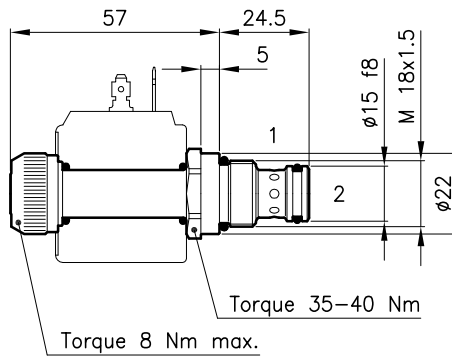
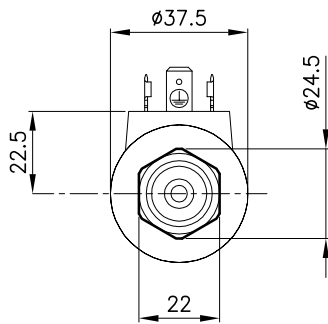

Ordering informations

ETD 20/2201

ETD 20/22.. = Valve type

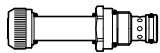

Circuits

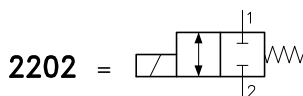
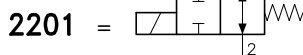

Codes:

ETD 20/2201	25 011 113
ETD 20/2202	25 011 110
External seals kit	90 620 100

ETD 20/22.. valves can be assembled on standard bodies 20-LO series; for dimensions see catalogue 16.010

On the ETD 20 valves must be assembled the Coils B20 series; for dimensions, features and codes see catalogues 09.900 and 09.901.