

Pos.	Antall	Produktnummer	Beskrivelse
1	1	EM15315-XXX	El.m. 15kW 230V/400V 3-fas IP-55
2	1	EPTS160A1	Standard 160L ståltank
3	1	EPTLS120F350	Tanklokk 70-160L/F350/FIR60/TCO500/Nivå
4	1	RQ1PLA45DE10B	Tannhjulspumpe gr.3 - 30,0cc
5	1	NHSD350NBR	Pakning for flens 350
6	1	NHS350173465	Mellomflens RV350/173/465
7	1	NHSX42AN3	Spidex kopling GG 42.N3
8	1	NHSX42B42	Spidex kopling GG 42/55.42
9	1	NHSX42K	Tannkrans Spidex 42, 92 shore
10	1	GM321020	Portflens 90gr. 1/2"x40
11	1	GM321030	Portflens 90gr. 3/4"x51
12	1	P766481	Returfilter FIR 60, uten element
13	1	FB180060100	Element CR 60-1
14	1	EFEC354X3F	Underplate EC3/54X3F
15	1	DTFT290	Manometerv. FT290-14 rett
16	1	STR06314250UA	Manometer 0-250bar Ø63 R1/4"
17	1	FB130501000	Påfyllingslokk/f. 10My TCO 500
18	1	FB150254120	Nivåglass LVOT 254/12
19	1	HE0500T080	Nivå/tempvakt 500mm 75gr.

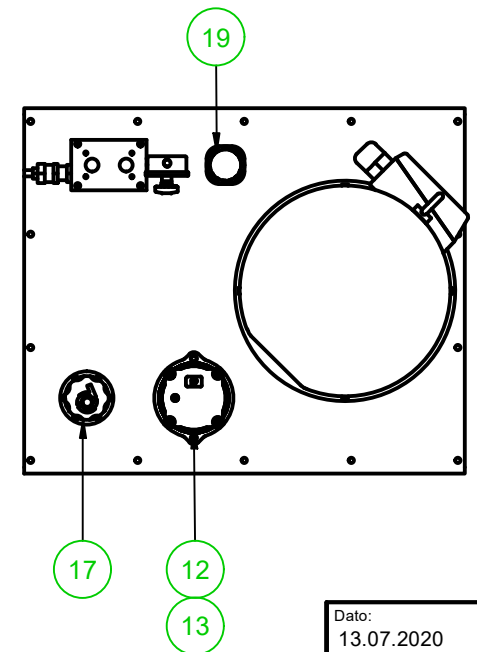
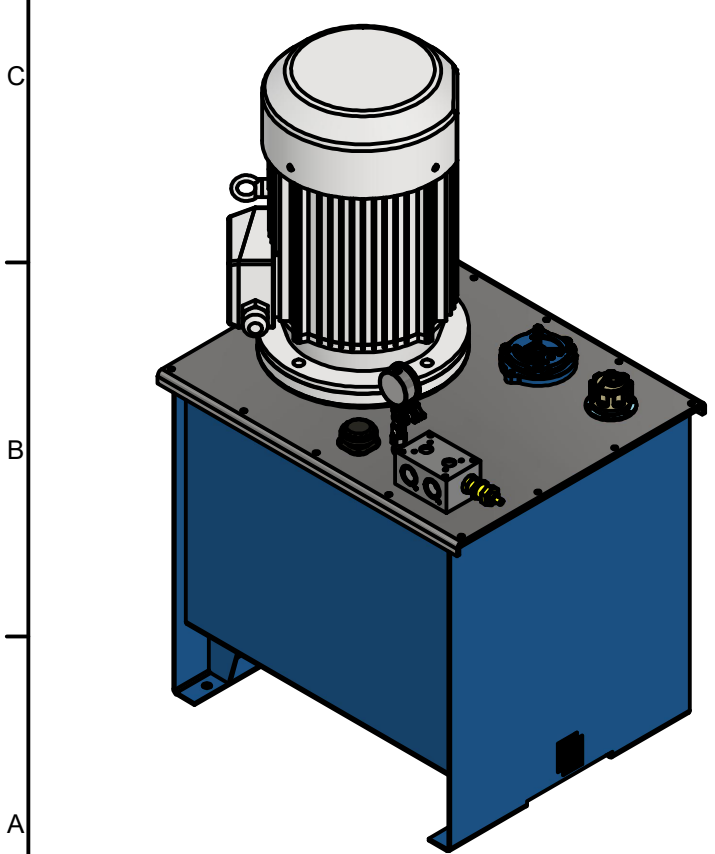

Dato: 13.07.2020	Designer: Marifat Abdugani	Revisjon:
Vår ref.: Anne Engebretsen	Kundenr.:	Ordrenr.:
Titel: Aggregat, 45.0l/min 200bar, 160L, 15kW Ståltank		
Godkjent:	Kommentar:	

Format: A3	Skala: 1 : 12	
EGIL ENG & CO. AS VÅR KUNNSKAP - DIN TRYGGHET		
Tegn. nr.: EEST160045200GA		
<small>DENNE TEGNING TILHØRER EGIL ENG & CO AS. KOPIERING ER IKKE TILLATT. ALLE RETTIGHETER I.H.T. GJELDENE LOVER. PROPERTY OF EGIL ENG & CO AS. REPRODUCTION NOT PERMITTED. DIESE ZEICHNUNG IST EIGENTUM DER FIRMA EGIL ENG & CO AS. NICHT GENEHMIGTE VERVIELFÄLTIGUNG SIND UNZULÄS SIG.</small>		