

1 2 3 4 5 6 7 8

A B C D E F

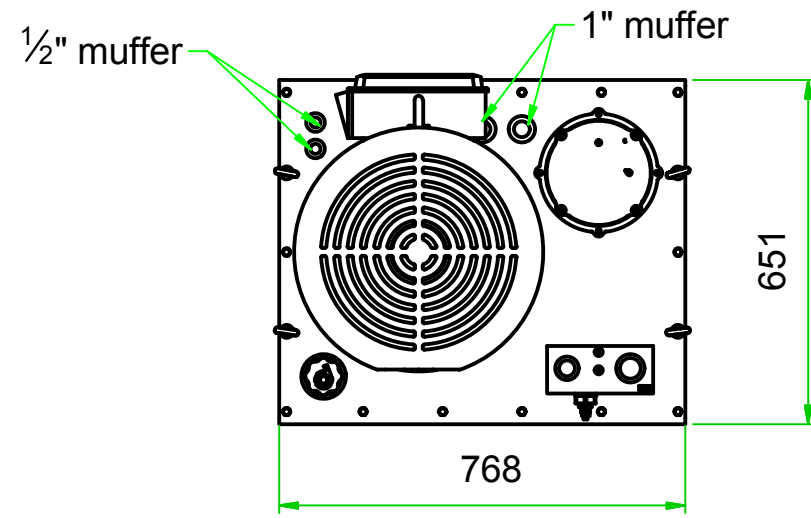
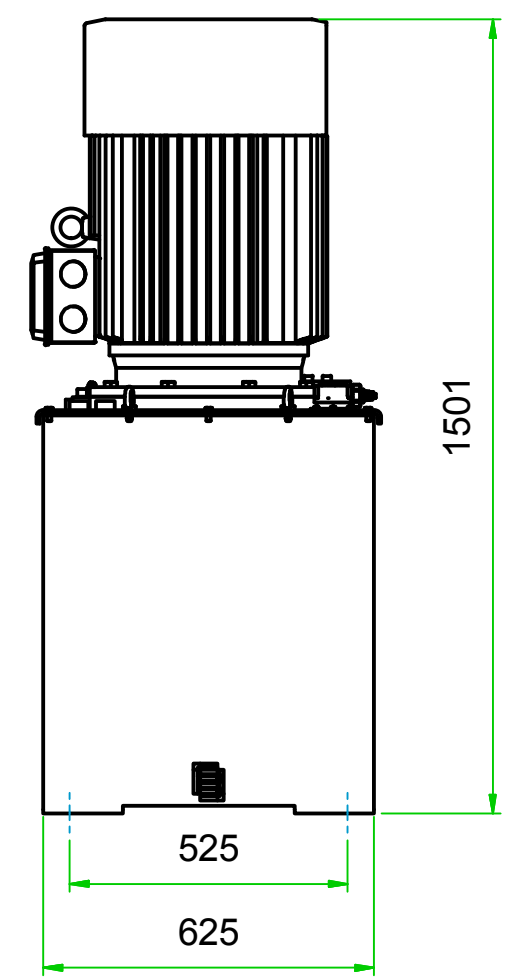
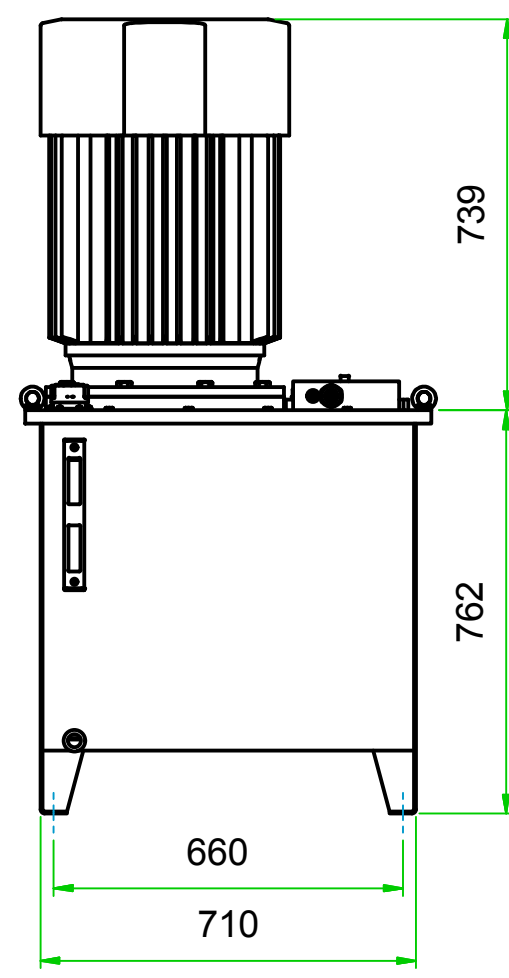
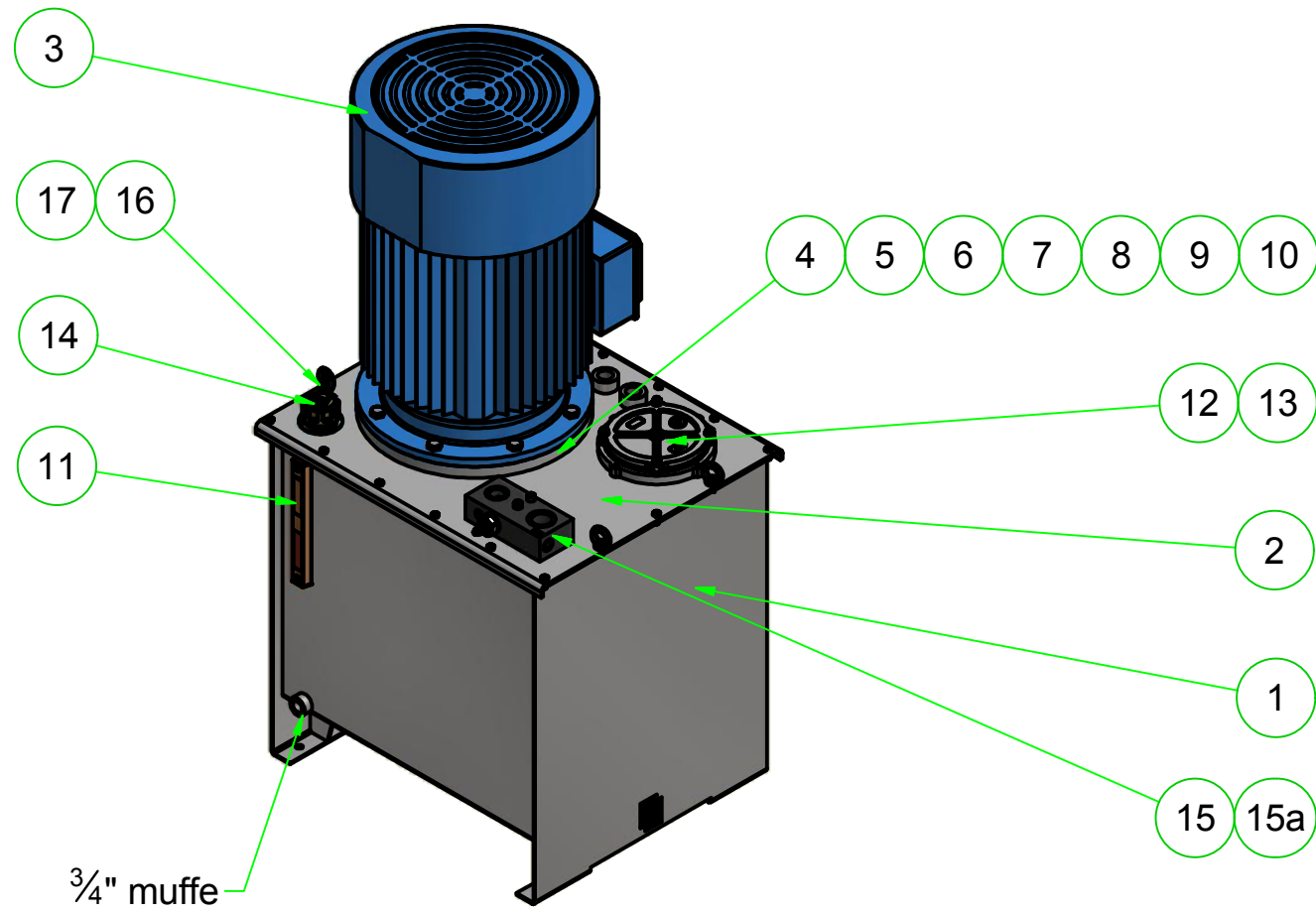

Pos.	Antall	Produktnummer	Beskrivelse
1	1	IMST1210022	Tank 250L IMS standard u/muffe
2	1	IMSL1506019	Tanklokk 250L F450 FIR500
3	1	BV119256	El.m. 45,0kW 230/400V 50Hz 1485rpm B5
4	1	LEW063	Stempelpumpe 63 ccm/o
5	1	NHS450262240	Mellomflens RV450/262/240 H1C55C
6	1	NHSX48A35	Spidex kopligng GG 48/60.35
7	1	NHSX48B60	Spidex kopligng GG 48/60.60 H7
8	1	NHSX48K	Tannkrans Spidex 48, 92 Shore
9	1	DTFT2576012	Tilbakeslagsventil 1/2" 55 l/min
10	1	DTFT2576034	Tilbakeslagsventil 3/4" 90 l/min
11	1	FB151254120	Nivåglass LVO 254/12
12	1	P766483	Returfilter FIR 500, uten element
13	1	FB180500100	Element CR 500/1, P171569
14	1	FB130501000	Påfyllingsl/f. 10 My TCO 500/501
15	1	E1009005	Blokk for bakmontert kran
15a	1	FC06180	Trykkbegrenser, LPI 50/Q-N 160l/min
16	4	IF18310000	Kontramutter M10 for løfteøye
17	4	IF13310000	Løfteøye M10 DIN 580

Dato: 26.10.2015	Designer: Bjørn Bergve Jensen	Revisjon: -
Vår ref.:	Kundenr.:	Ordrenr.:
Tittel: Aggr. 93 l/min 290 bar 250L 45kW		
Godkjent:	Kommentar:	

Format: A3	Skala:	
Egil Eng & CO. AS Jernkroken 7, 0976 Oslo Tlf.: 22 90 05 60, www.egileng.no		
Tegn. nr.: EEC093290250L		
<small>DENNE TEGNING TILHØRER EGIL ENG & CO AS. KOPIERING ER IKKE TILLATT. ALLE RETTIGHETER I.H.T. GJELDENE LOVER. PROPERTY OF EGIL ENG & CO AS. REPRODUCTION NOT PERMITTED. DIESE ZEICHNUNG IST EIGENTUM DER FIRMA EGIL ENG & CO AS. NICHT GENEHMIGTE VERVIELFÄLTIGUNG SIND UNZULÄS SIG.</small>		

1 2 3 4 5 6 7 8