

Technical features

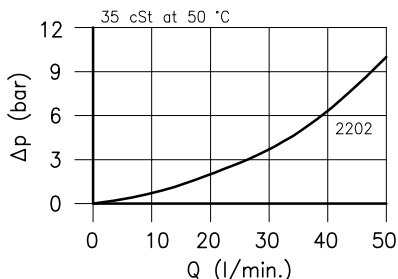

Cavity	(For dimensions see catalogue 17.000)	S 50/2
Max. flow	02/02-MO (l/min.)	50
Max. pressure	(bar)	315
Response time	(ms)	40 - 80
It change in function of circuit, pressure, flow and fluid viscosity. (Mean value)		
Fluid viscosity range	(cSt)	2.8 - 380
Fluid temperature range	(°C)	-20 +80
Mass	(kg)	0.460
Hydraulic fluid; mineral oil HM and HV ISO 6074		
Recommended filtration; 19/15 ISO 4466 (25 μ absolutes)		
Standard seals in Polyurethane and Buna N		

Dimensions

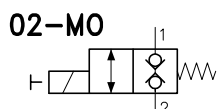
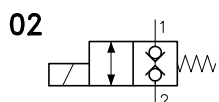
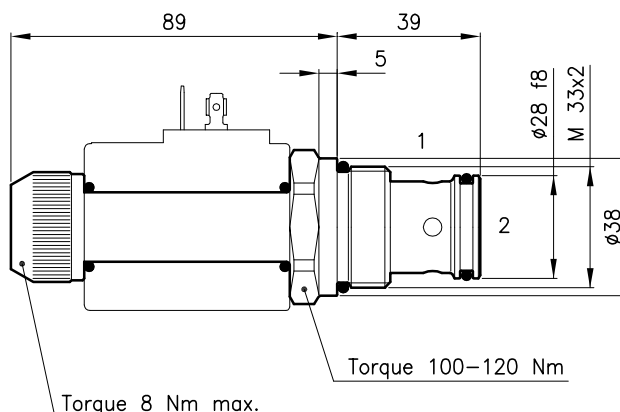
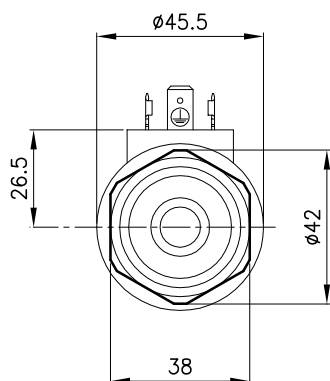

Ordering informations

ECD 50/2202-MO

ECD 50/22.. = Valve type

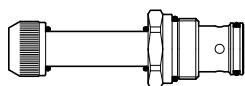

Circuits

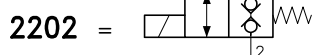

MO = Manual override
(Omit if not request)

Codes:

ECD 50/2202	55 011 113
ECD 50/2202-MO	55 011 114
External seals kit	90 620 106

ECD 50/22.. valves can be assembled on standard bodies 50-L0 series; for dimensions see catalogue 16.010

On the ECD 50 valves must be assembled the Coils B50 series; for dimensions, features and codes see catalogues 09.900 and 09.901.