



DSE3G*

DIRECTIONAL VALVE WITH PROPORTIONAL CONTROL AND DIGITAL INTEGRATED ELECTRONICS

**SUBPLATE MOUNTING
ISO 4401-03**

**p max 350 bar
Q max 40 l/min**

MOUNTING INTERFACE

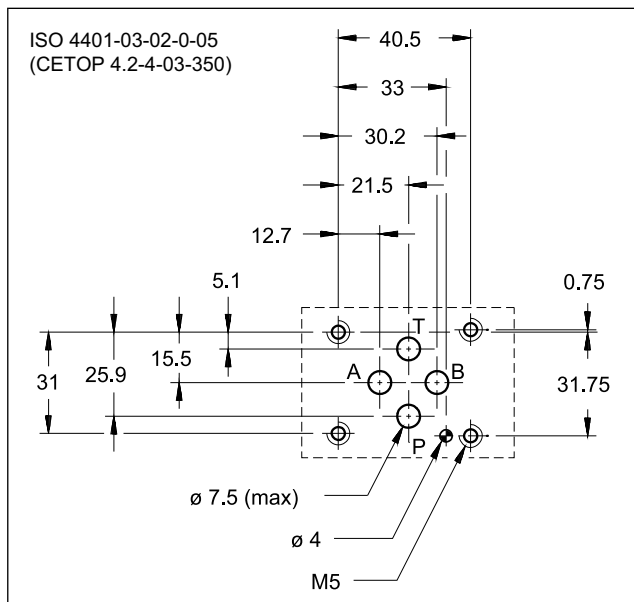

OPERATING PRINCIPLE

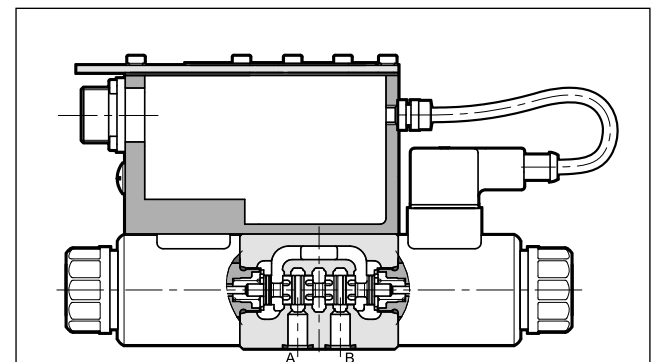

- The DSE3G* are proportional directional valves, direct operated, with digital integrated electronics and with mounting interface according to ISO 4401-03 standards.
- They control the positioning and the speed of hydraulic actuators.
- They are available with different types of electronics, with analogue or fieldbus interfaces.
- The valves are easy to install. The driver manages digital settings directly.

PERFORMANCES

(obtained with mineral oil with viscosity of 36 cSt at 50°C and p = 140 bar)

Max operating pressure: - P - A - B ports - T port	bar	350 210
Nominal flow with Δp 10 bar P-T	l/min	1 - 4 - 8 - 16 - 26
Response times	see paragraph 6	
Hysteresis	% of Q max	< 3%
Repeatability	% of Q max	< $\pm 1\%$
Electrical characteristics	see paragraphs 3 and 4	
Ambient temperature range	°C	-20 / +60
Fluid temperature range	°C	-20 / +80
Fluid viscosity range	cSt	10 ÷ 400
Fluid contamination degree	according to ISO 4406:1999 class 18/16/13	
Recommended viscosity	cSt	25
Mass: single solenoid valve double solenoid valve	kg	1.9 2.4

HYDRAULIC SYMBOLS (typical)

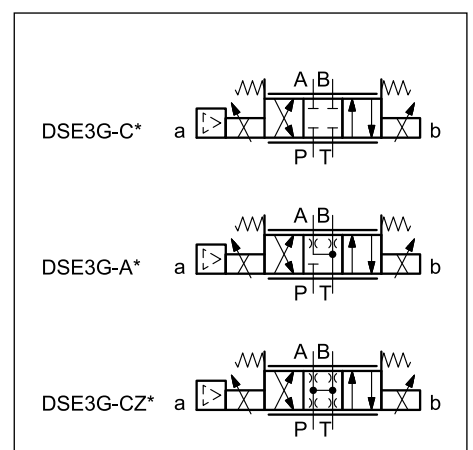

1 - IDENTIFICATION CODES AND CONFIGURATION

1.1 - Standard electronics

D	S	E	3	G	-	/	31	-	K11
----------	----------	----------	----------	----------	---	---	-----------	---	------------

Direct operated directional control valve

Electric proportional control

Size ISO 4401-03

Standard electronics for open loop

Spool type: _____

C = closed centres
CZ = with software overstep of the overlap
A = open centres

Nominal flow rate (see par. 1.2) _____

Solenoid position (omit for 2 solenoids configuration): _____

SA = 1 solenoid on side A

Pin C function:
A = external enable
B = internal enable
C = 0V monitor

Connection: 6 pin + PE

Reference signal:
E0 = voltage $\pm 10V$ **E1** = current $4 \div 20mA$

Seals:
N = NBR seals for mineral oil (**standard**)
V = FPM seals for special fluids

Series No. (the overall and mounting dimensions remain unchanged from 30 to 39)

1.2 - Configurations

Valve configuration depends on the combination of the following elements:
number of proportional solenoids, spool type, rated flow.

Configuration 2 solenoids :
3 positions with spring centreing

Configuration 1 solenoid on side A "SA":
2 positions (central + external) with spring centreing

*	Controlled flow with $\Delta p 10$ bar P-T
01	1 l/min
04	4 l/min
08	8 l/min
16	16 l/min
16/08	16 (P-A) / 08 (B-T) l/min
26	26 l/min
26/13	26 (P-A) / 13 (B-T) l/min

1.3 - Compact electronics

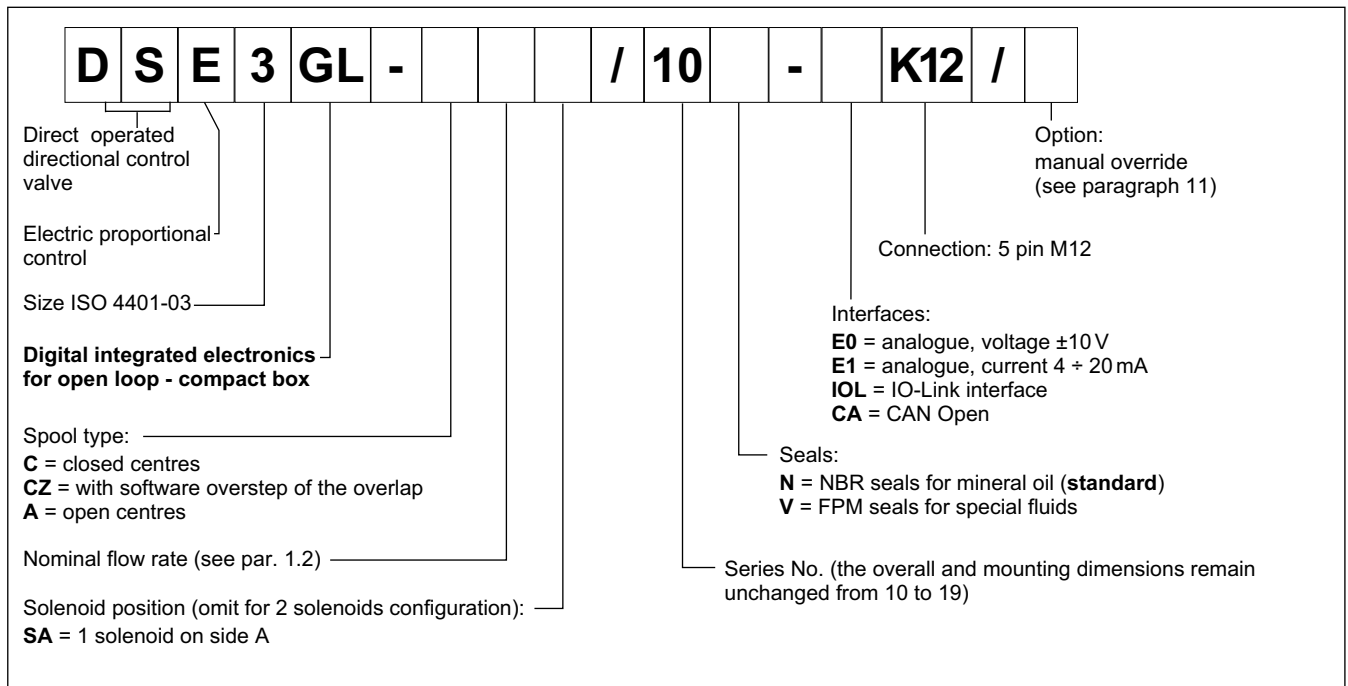

1.4 - Electronics with fieldbus communication

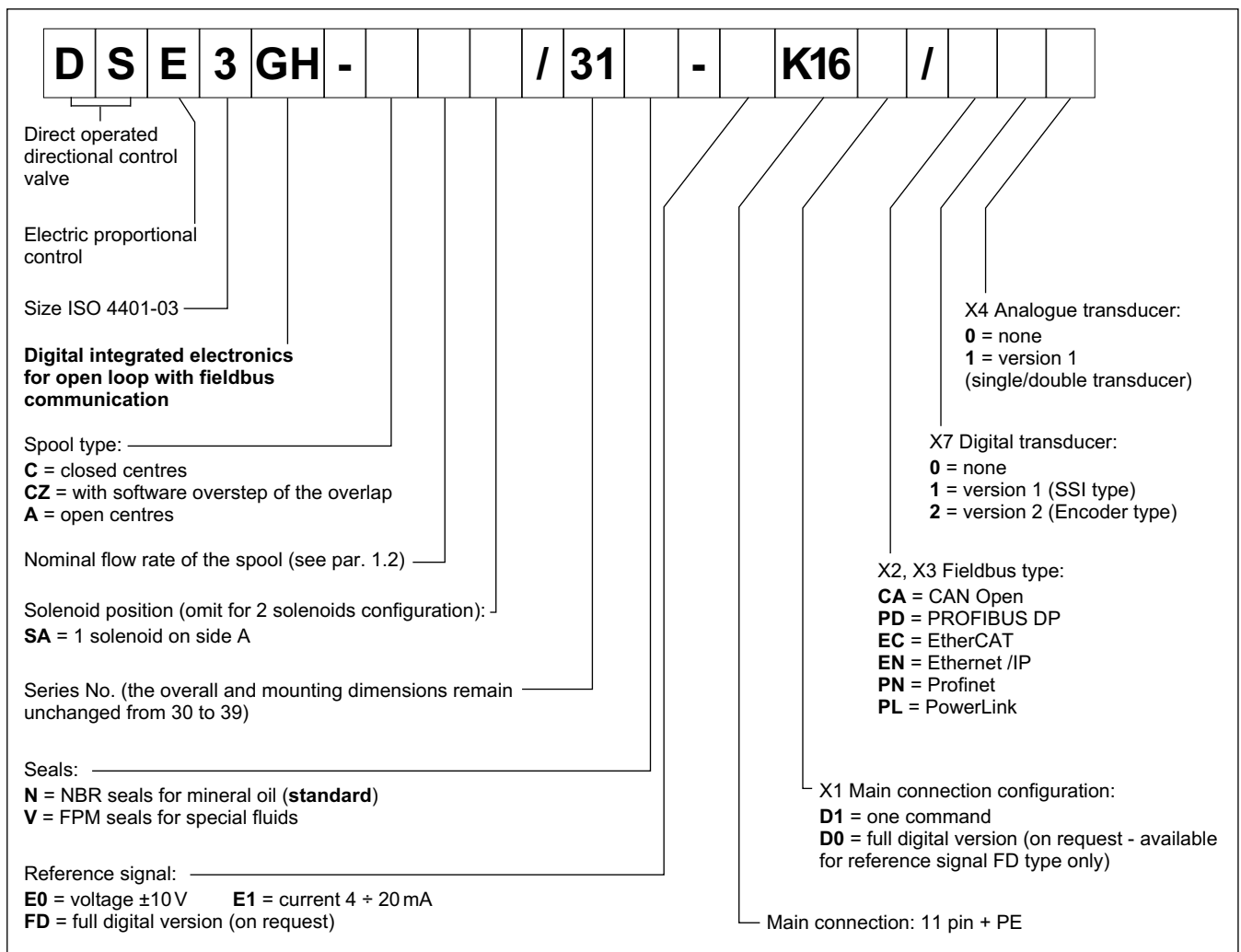

2 - ELECTRONICS COMMON DATA

Duty cycle		100% (continuous operation)
Protection class according to EN 60529		IP65 / IP67
Supply voltage	V DC	24 (from 19 to 30 VDC), ripple max 3 Vpp
Power consumption	VA	25
Maximum solenoid current	A	1.88
Fuse protection, external	A	3
Managed breakdowns		Overload and electronics overheating, cable breakdown, supply voltage failures
Electromagnetic compatibility (EMC) emissions EN 61000-6-4, immunity EN 61000-6-2		According to 2014/30/EU standards

3 - DSE3G - STANDARD ELECTRONICS

3.1 - Electrical characteristics

Command signal:	voltage (E0) current (E1)	V DC mA	± 10 (Impedance $R_i = 11 \text{ k}\Omega$) $4 \div 20$ (Impedance $R_i = 58 \text{ }\Omega$)
Monitor signal (current to solenoid):	voltage (E0) current (E1)	V DC mA	± 10 (Impedance $R_o > 1 \text{ k}\Omega$) $4 \div 20$ (Impedance $R_o = 500 \text{ }\Omega$)
Communication for diagnostic			LIN-bus Interface (by means of the optional kit)
Connection			6 pin + PE (MIL-C-5015-G - DIN EN 175201-804)

3.2 - On-board electronics diagrams

VERSION A - External Enable

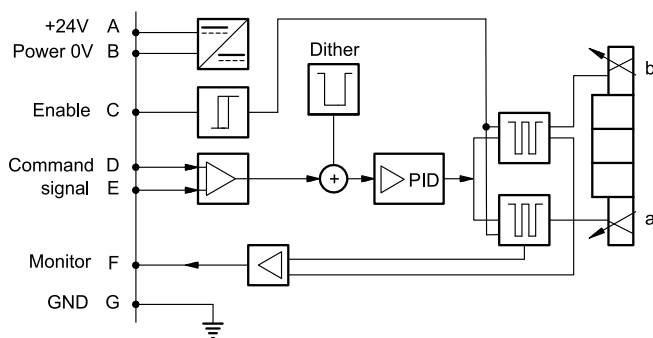

VERSION B - Internal Enable

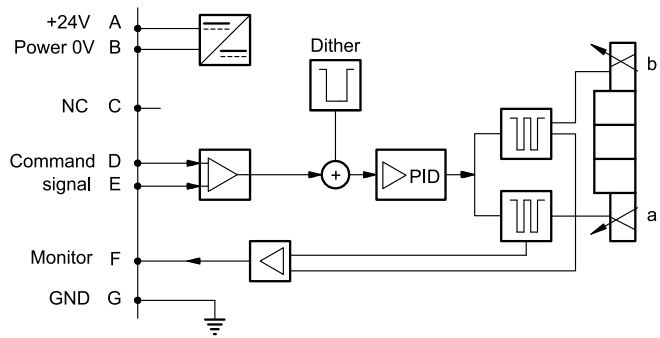

VERSION C - 0V Monitor

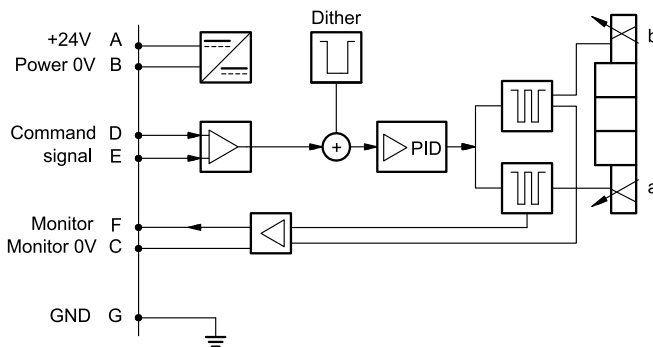

3.3 - Versions with voltage command (E0)

The reference signal is between -10V and +10V on double solenoid valve, and 0 + 10V on single solenoid valve SA. The monitor feature of versions B and C becomes available with a delay of 0,5 sec from the power-on of the card.

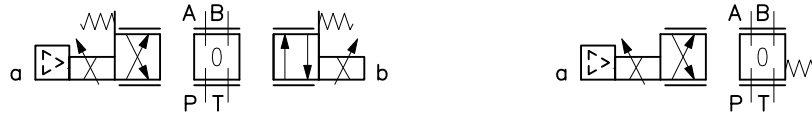

COMMAND	-10V	0V	+10V	COMMAND	+10V	0V
MONITOR	-10V	0V	+10V	MONITOR	+10V	0V

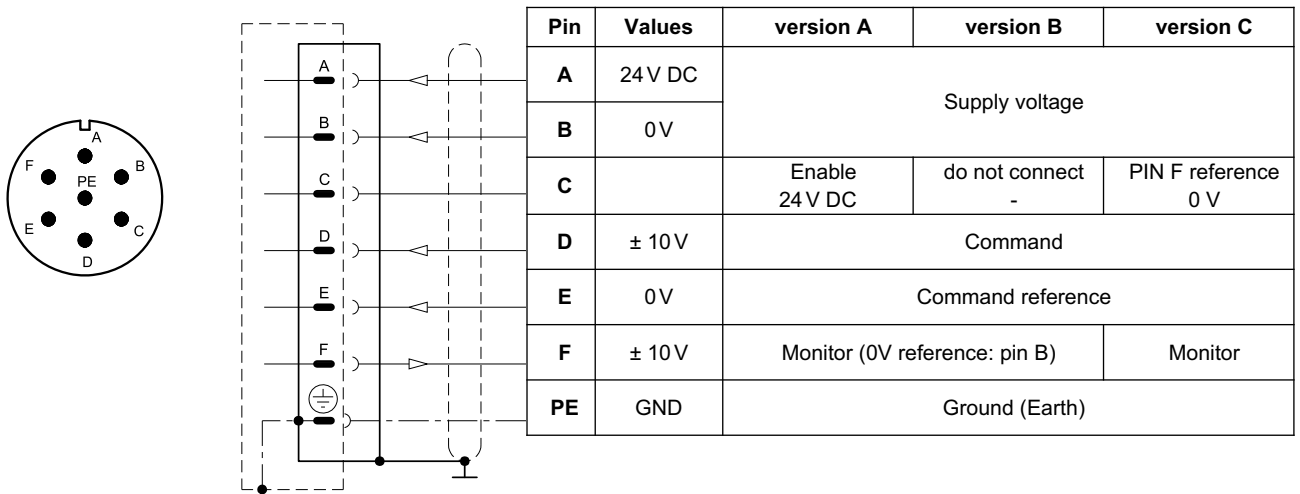

3.4 - Versions with current command (E1)

The reference signal is supplied in current 4 ± 20 mA. If the current for command is lower, the card shows a breakdown cable error. To reset the error is sufficient restoring the signal.

The monitor feature of versions B and C becomes available with a delay of 0,5 sec from the power-on of the card.

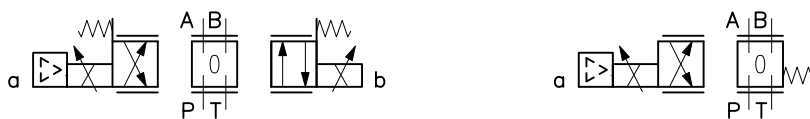

COMMAND	4 mA	12 mA	20 mA	COMMAND	20 mA	4 mA
MONITOR	4 mA	12 mA	20 mA	MONITOR	20 mA	4 mA

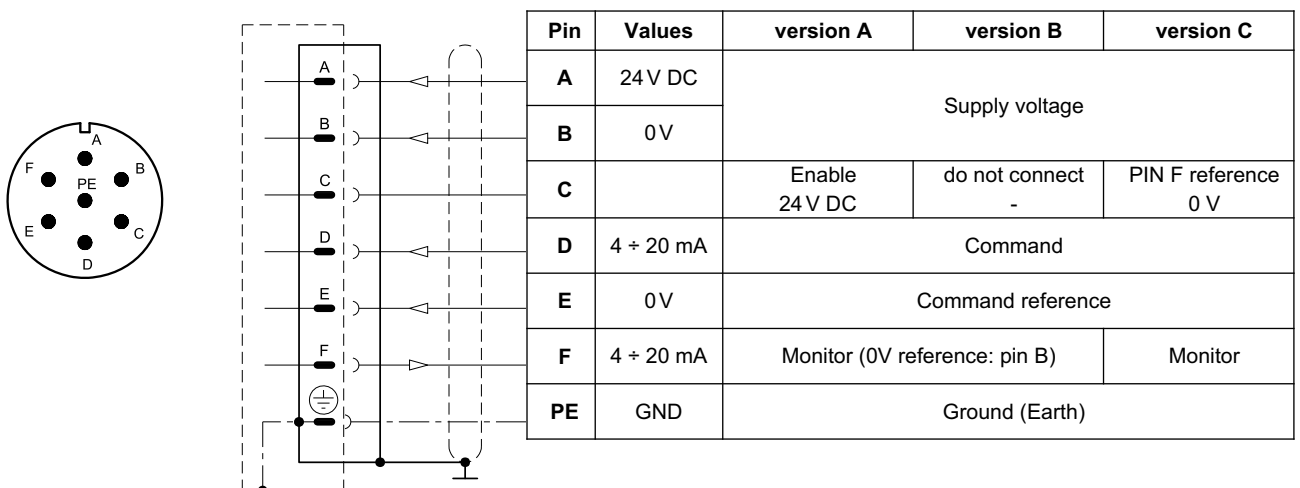

4 - DSE3GL - COMPACT ELECTRONICS

In versions 'IOL' and 'CA' pin 3 and pin 5 are galvanic isolated up to 100 V to avoid earth loops. In IO-Link networks, the length of the connecting cables is limited to 20 metres.

4.1 - Electrical characteristics

Command signal: voltage (E0) current (E1)	V DC mA	± 10 (Impedance $R_i = 11 \text{ k}\Omega$) $4 \div 20$ (Impedance $R_i = 58 \text{ }\Omega$)
Monitor signal (current to solenoid): voltage (E0) current (E1)	V DC mA	$0 \div 5$ (Impedance $R_o > 1 \text{ k}\Omega$) $4 \div 20$ (Impedance $R_o = 500 \text{ }\Omega$)
IO-Link communication (IOL): Data rate	kBaud	IO-Link Port Class B 230,4
Can Open communication (CA): Data rate	kbit	$10 \div 1000$
Connection		5-pin M12 code A (IEC 61076-2-101)

4.2 - Pin tables

'E0' connection



Pin	Values	Function
2	24 V DC	Supply voltage (solenoid and logic)
5	0 V	
1	$\pm 10 \text{ V}$	Command
3	0 V	Command reference
4	$0 \div 5 \text{ V}$	Monitor (0V reference: pin 5)

'E1' connection



Pin	Values	Function
2	24 V DC	Supply voltage (solenoid and logic)
5	0 V	
1	$4 \div 20 \text{ mA}$	Command
3	0 V	Command reference
4	$4 \div 20 \text{ mA}$	Monitor (0V reference: pin 5)

'IOL' connection



Pin	Values	Function
2	2L+ 24 V DC	Supply of the power stage
5	2L- 0 V (GND)	Internal galvanic isolation from PIN 3
1	1L+ +24 V DC	IO-Link supply voltage
3	1L- 0 V (GND)	
4	C/Q	IO-Link Communication

'CA' connection



Pin	Values	Function
1	CAN_SH	Shield
2	24 V DC	Supply voltage
3	0 V (GND)	
4	CAN_H	Bus line (high)
5	CAN_L	Bus line (low)

5 - DSE3GH - FIELDBUS ELECTRONICS

The 11+ PE pin connection allows separate supply voltage for electronics and solenoids.

Command - valve position schemes as for the standard electronics. Please refer to pictures in par. 3.3 and 3.4.

5.1 - Electrical characteristics

Command signal: voltage (E0) current (E1) digital (FD)	V DC mA	± 10 (Impedance $R_i = 11 \text{ k}\Omega$) $4 \div 20$ (Impedance $R_i = 58 \text{ }\Omega$) via fieldbus
Monitor signal (current to solenoid): voltage (E0) current (E1)	V DC mA	± 10 (Impedance $R_o > 1 \text{ k}\Omega$) $4 \div 20$ (Impedance $R_o = 500 \text{ }\Omega$)
Communication / diagnostic		via Bus register
Communication interface standards CAN Open PROFIBUS DP EtherCAT, Ethernet /IP, Profinet, PowerLink		EN 50325-4+DS408 EN 50170-2 / IEC 61158 IEC 61158
Communication physical layer CAN Open PROFIBUS DP EtherCAT, Ethernet /IP, Profinet, PowerLink		optical insulated CAN ISO 11898 optical insulated RS485 fast ethernet, insulated 100 Base TX
Power connection		11 pin + PE (DIN 43651)

5.2 - X1 Main connection pin table

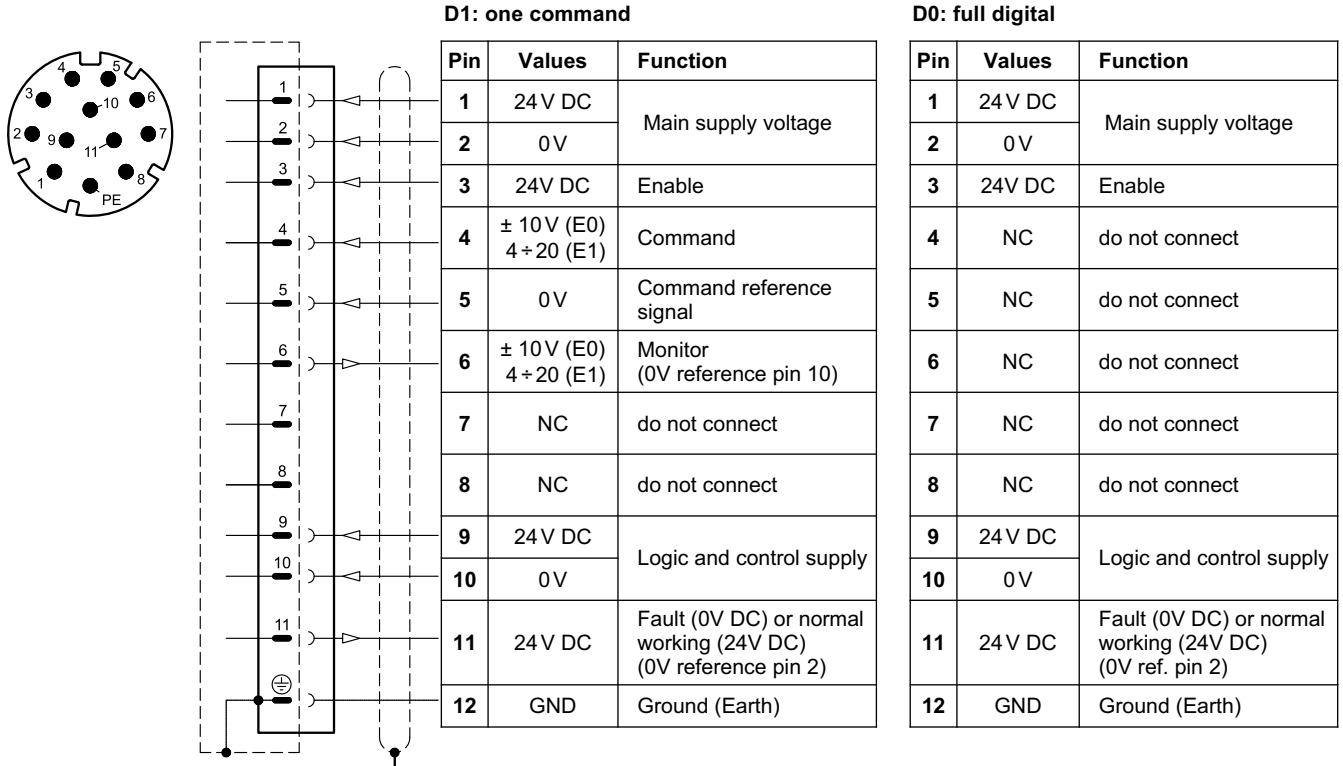

5.3 - FIELDBUS connections

Please wire following guidelines provided by the relative standards communication protocol.

5.3.1 - Communication connection CA (CAN Open)

X2 (IN) connection: M12 A 5 pin female



Pin	Values	Function
1	CAN_SH	Shield
2	NC	Do not connect
3	GND	Signal zero data line
4	CAN_H	Bus line (high)
5	CAN_L	Bus line (low)

X3 (OUT) connection: M12 A 5 pin male



Pin	Values	Function
1	CAN_SH	Shield
2	NC	Do not connect
3	GND	Signal zero data line
4	CAN_H	Bus line (high)
5	CAN_L	Bus line (low)

5.3.2 - Communication connection PD (PROFIBUS DP)

X2 (IN) connection: M12 B 5 pin male (IN)



Pin	Values	Function
1	+5 V	Termination supply signal
2	PB_A	Bus line (high)
3	0 V	Data line and termination signal 0
4	PB_B	Bus line (low)
5	SHIELD	

X3 (OUT) connection: M12 B 5 pin female



Pin	Values	Function
1	+5 V	Termination supply signal
2	PB_A	Bus line (high)
3	0 V	Data line and termination signal 0
4	PB_B	Bus line (low)
5	SHIELD	

5.3.3 - Communication connections: EC (EtherCat), EN (Ethernet/IP), PN (PROFINET), PL (POWERLINK)

X2 (IN) connection: M12 D 4 pin female



Pin	Values	Function
1	TX+	Transmitter
2	RX+	Receiver
3	TX-	Transmitter
4	RX-	Receiver
HOUSING	shield	

X3 (OUT) connection: M12 D 4 pin female



Pin	Values	Function
1	TX+	Transmitter
2	RX+	Receiver
3	TX-	Transmitter
4	RX-	Receiver
HOUSING	shield	

NOTE: Shield connection on connector housing is recommended.

5.4 - Digital transducer connection

X7 connection: M12 A 8 pin female

VERSION 1: SSI type

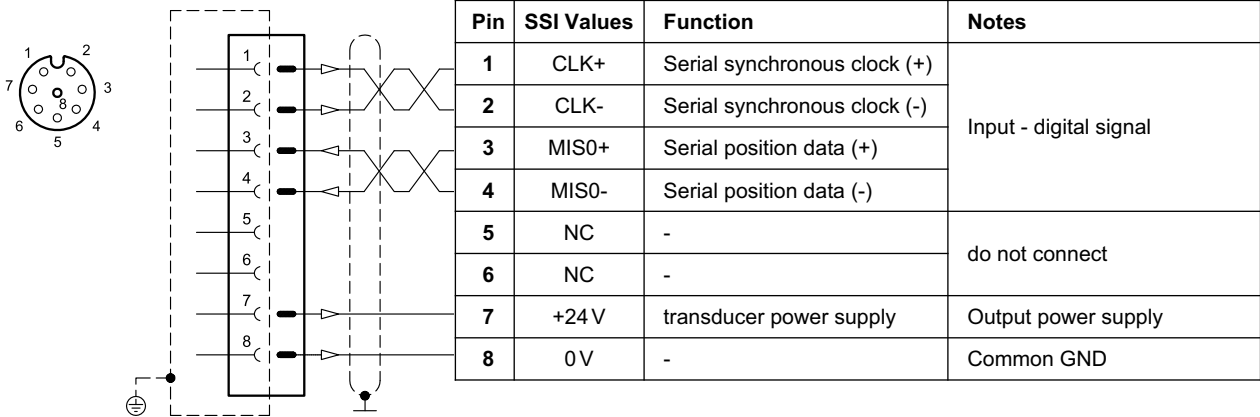

VERSION 2: ENCODER type

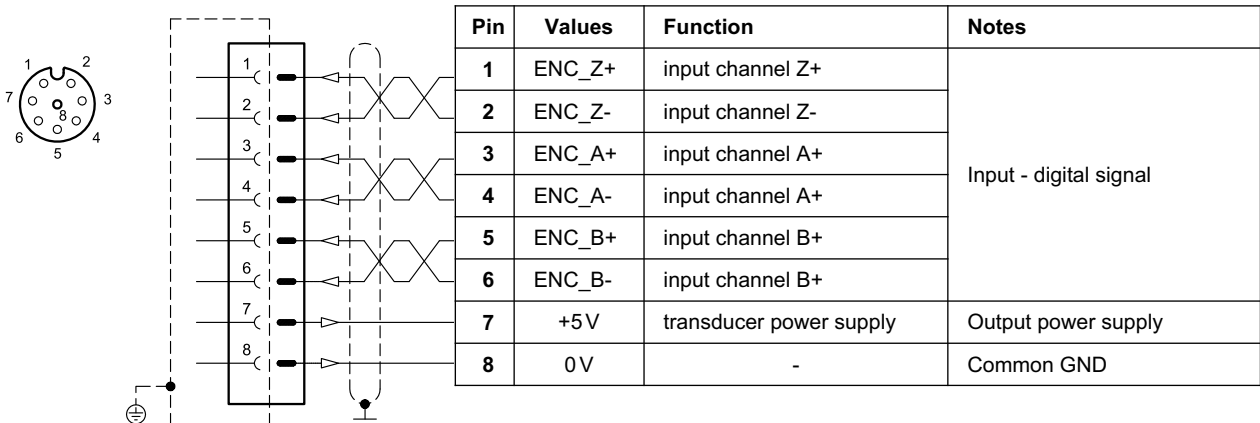

5.5 - Analogue transducer connection

X4 connection: M12 A 4 pin female

VERSION 1: single / double transducer

(single or double is a software-selectable option)

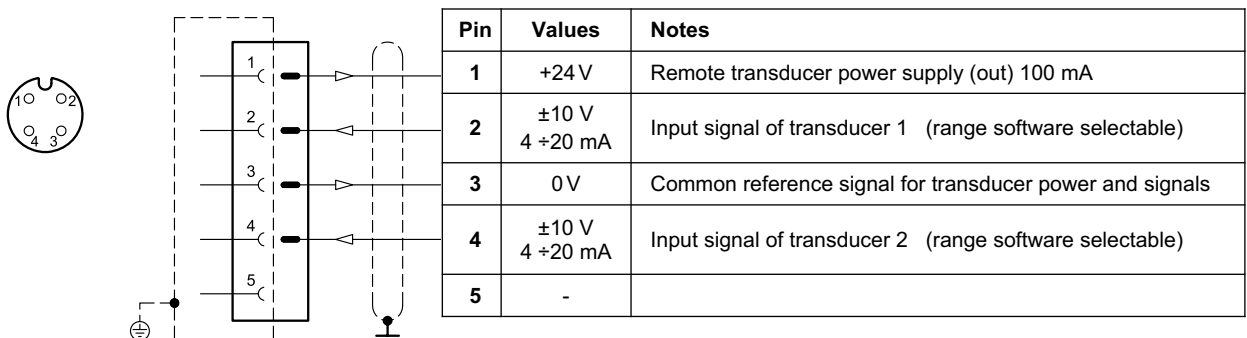

6 - CHARACTERISTIC CURVES

(obtained with mineral oil with viscosity of 36 cSt at 50°C and p = 140 bar)

Typical flow rate curves at constant Δp related to the reference signal and measured for the available spools. The Δp values are measured between P and T valve ports.

Curves obtained after linearization of the characteristic curve in factory, through the digital amplifier. The linearization of the curve is performed with a constant Δp of 5 bar and by setting the value of flow start at 20% of the reference signal.

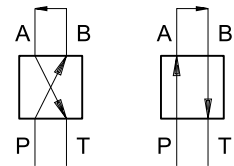

SPOOL TYPE C01/A01

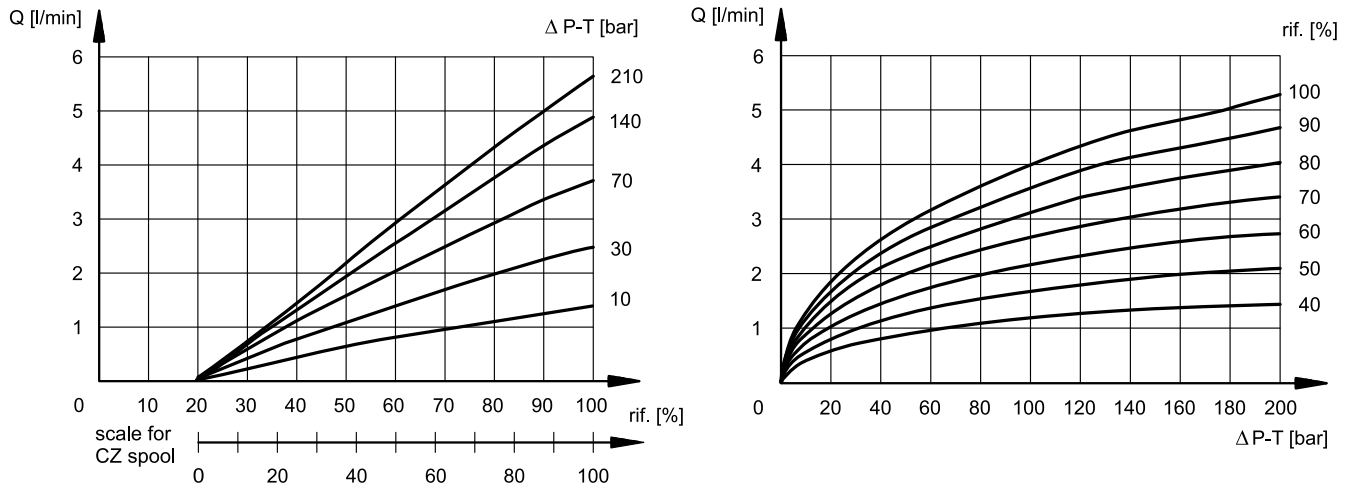

SPOOL TYPE C04/A04

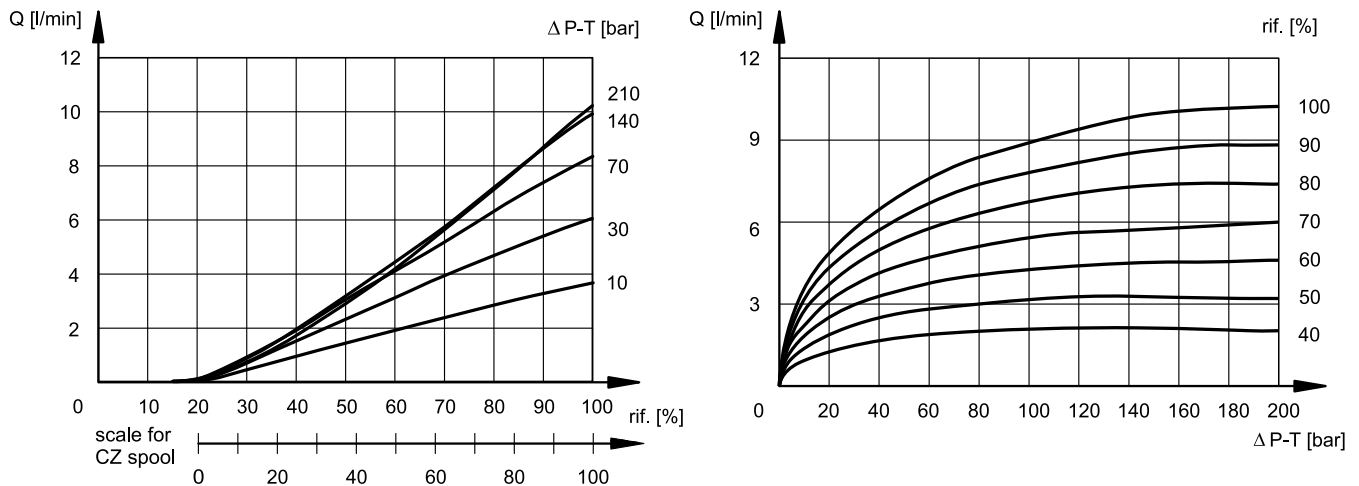

SPOOL TYPE C08/A08

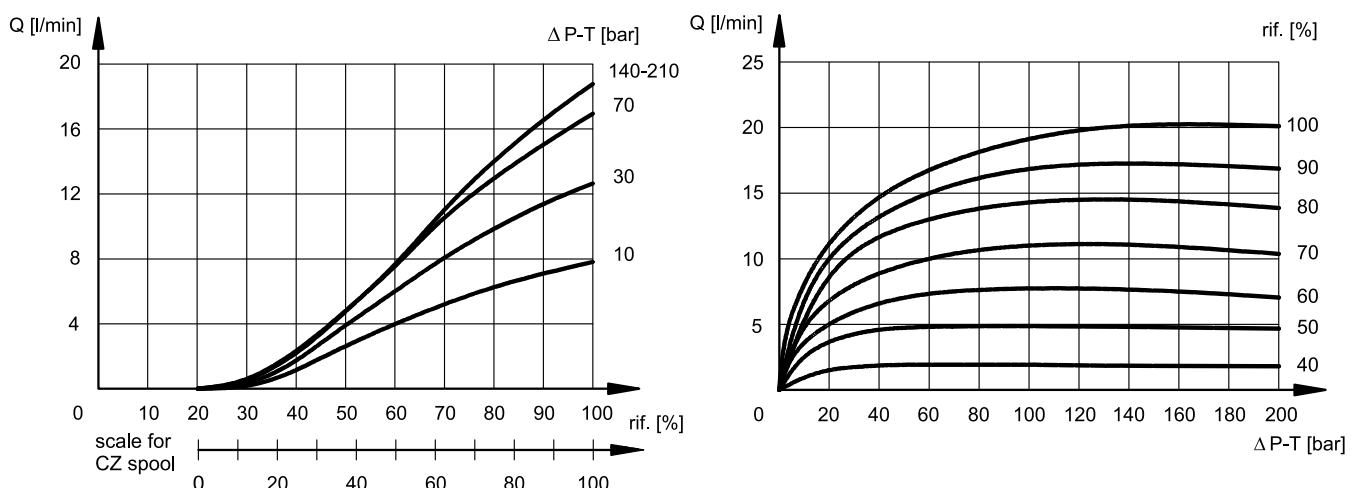

SPOOL TYPE C16/A16

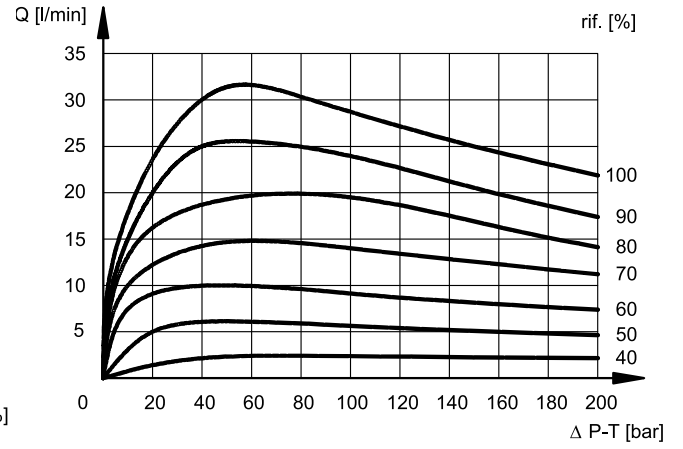
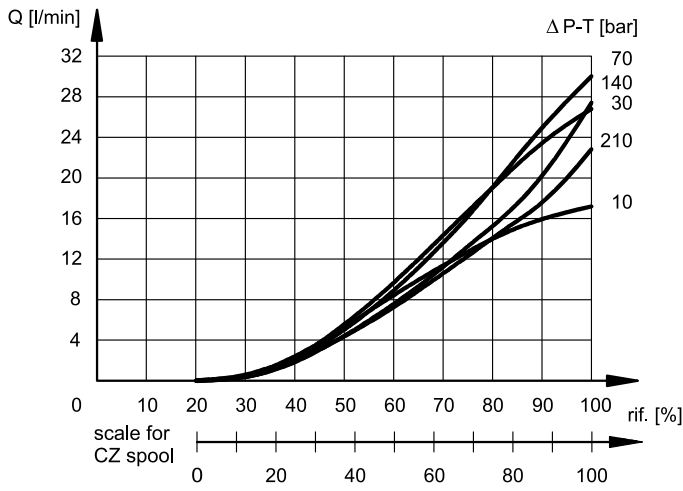

SPOOL TYPE C26/A26

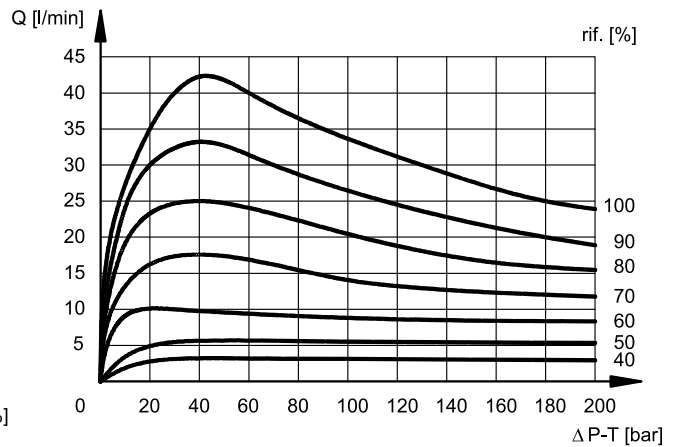
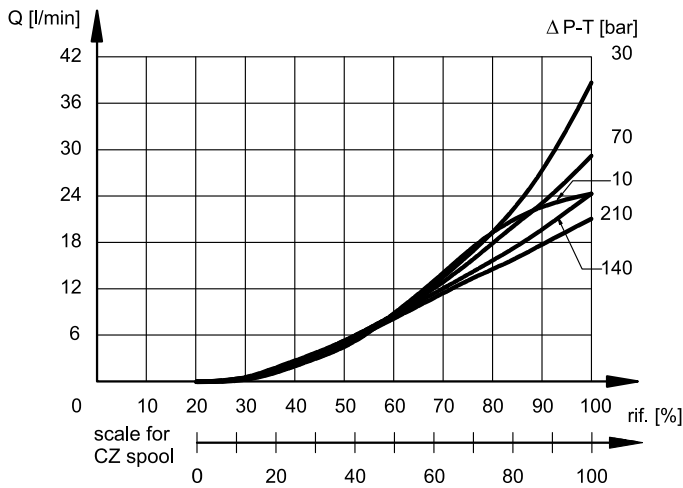

7 - RESPONSE TIMES

(obtained with mineral oil with viscosity of 36 cSt at 50°C and p = 140 bar)

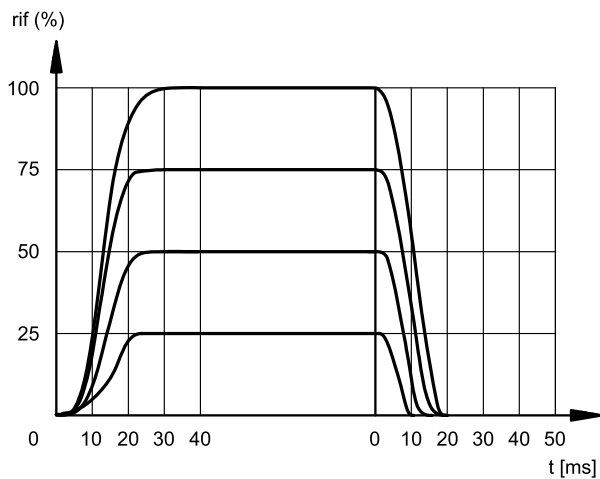

8 - DSE3G - OVERALL AND MOUNTING DIMENSIONS

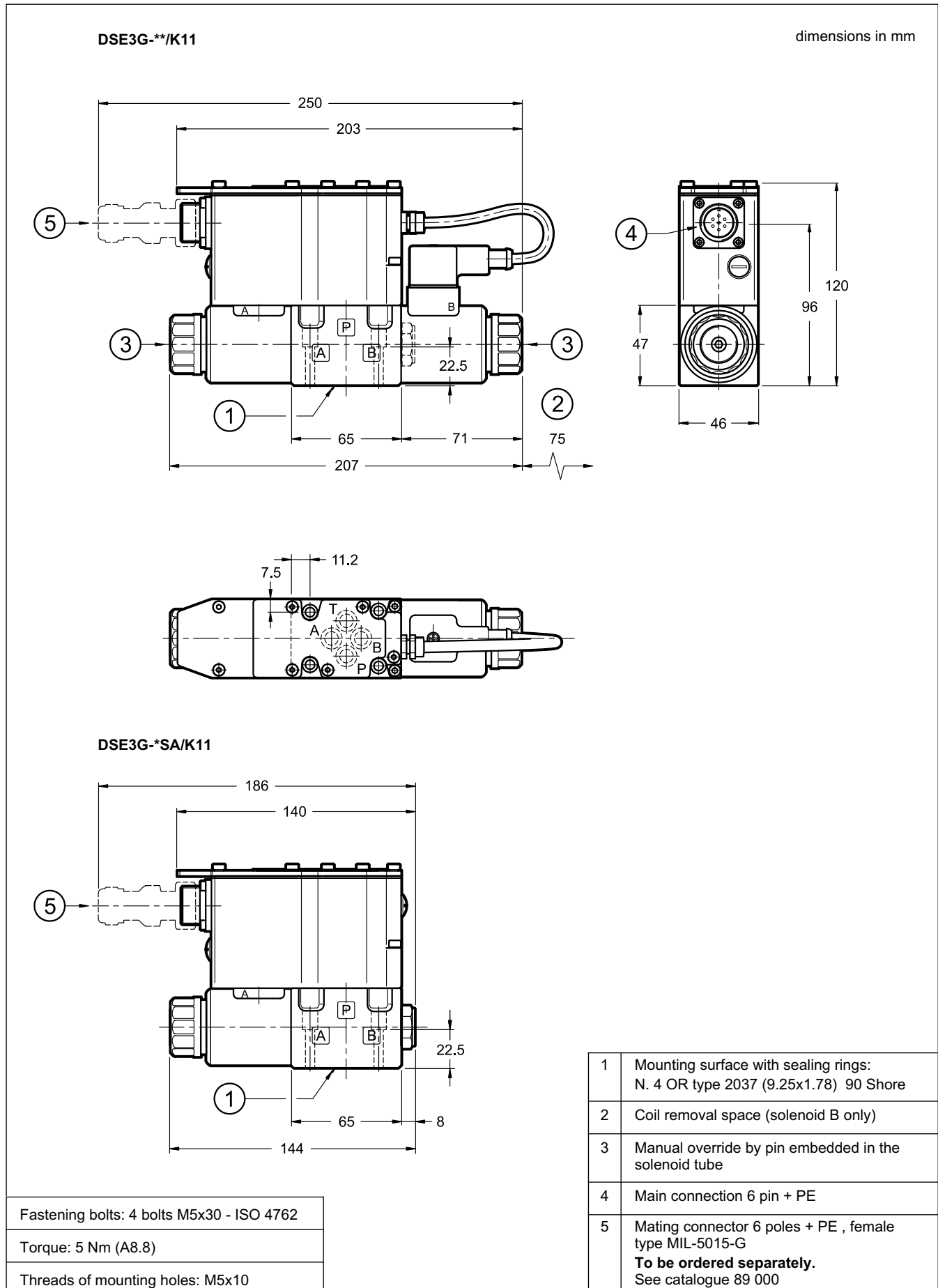

9 - DSE3GL - OVERALL AND MOUNTING DIMENSIONS

DSE3GL-*/K12

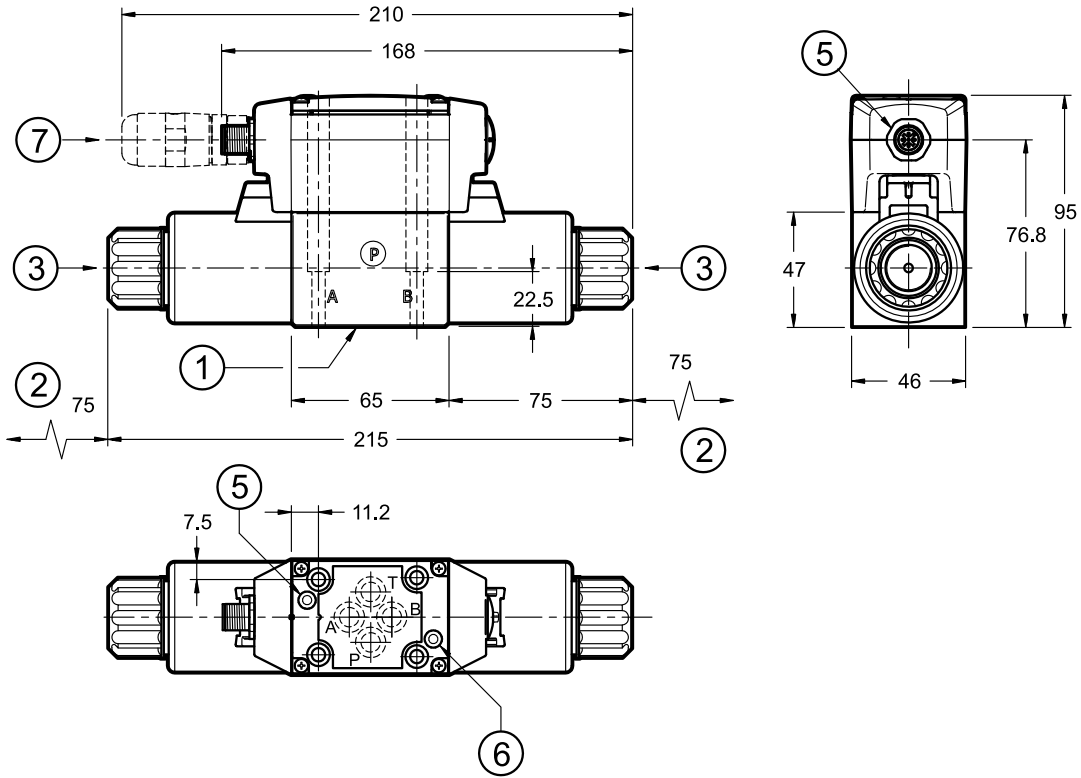

DSE3GL-*/SA/K12

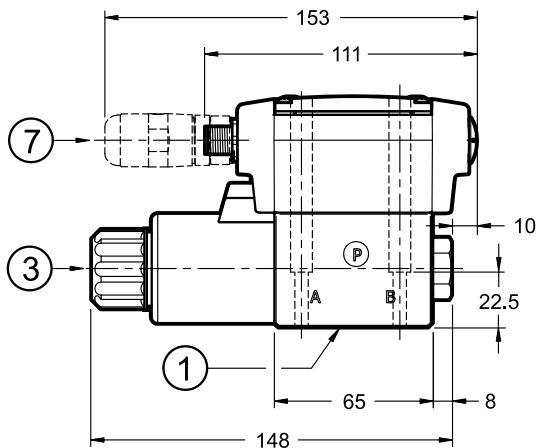

Fastening bolts: 4 bolts M5x30- ISO 4762

Torque: 5 Nm (A8.8)

Threads of mounting holes: M5x10

1	Mounting surface with sealing rings: N. 4 OR type 2037 (9.25x1.78) 90 Shore
2	Coil removal space
3	Standard manual override embedded in the solenoid tube
4	Connection M12 A 5 pin
5	L1 LED
6	L2 LED
7	Mating connector M12 5 poles - code A, female To be ordered separately. See catalogue 89 000

10 - DSE3GH - OVERALL AND MOUNTING DIMENSIONS

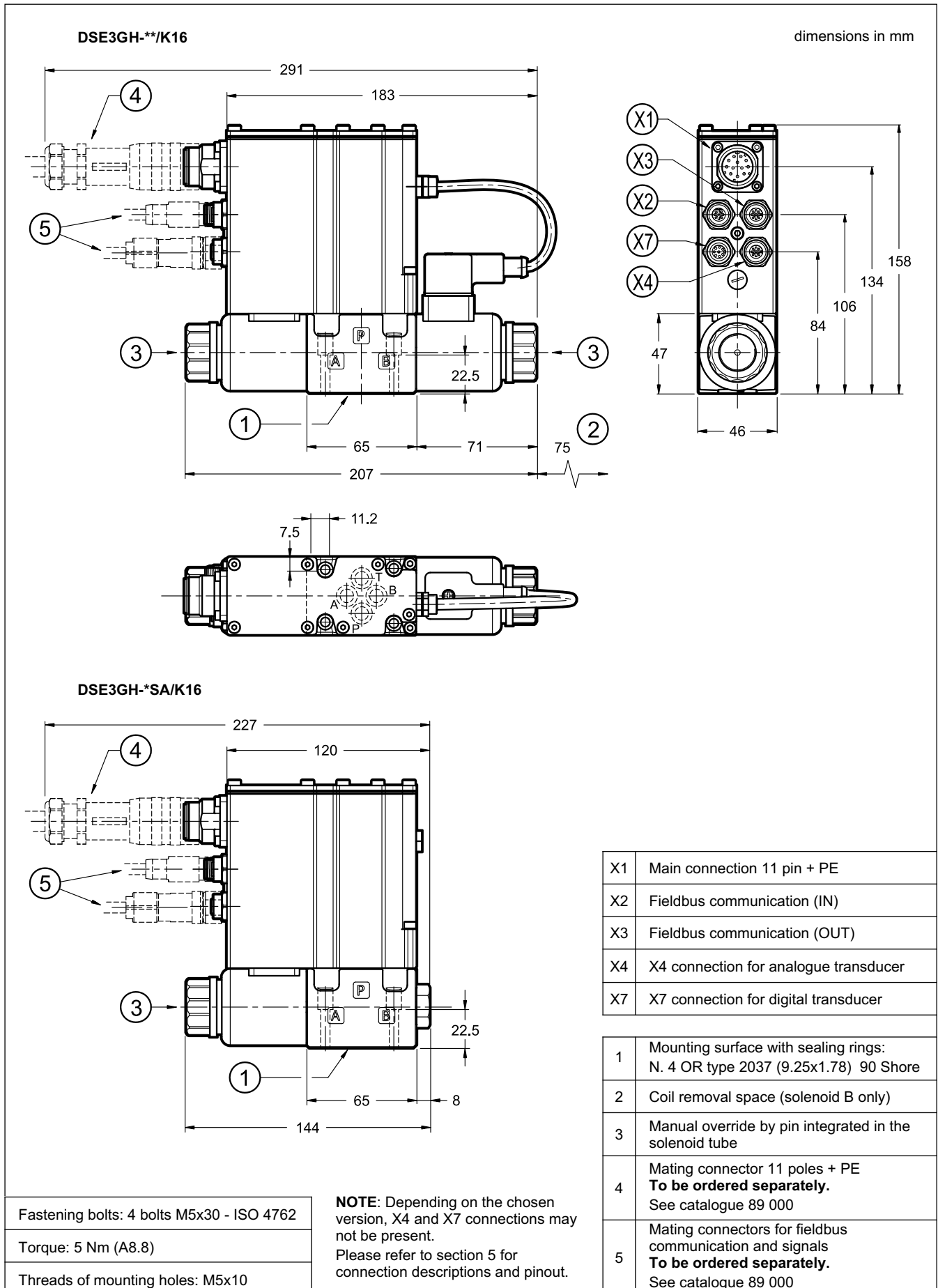

11 - MANUAL OVERRIDE

These valves have solenoids whose pin for manual operation is integrated in the tube. Actuate this override by pushing it with a suitable tool, minding not to damage the sliding surface.

Three other types of manual overrides can fit the DSE3GL valve:

- **CM** version, manual override boot protected
- **CK1** version, turning knob override.
- **CS** version, with metal ring nut provided with a M8 screw and locknut.

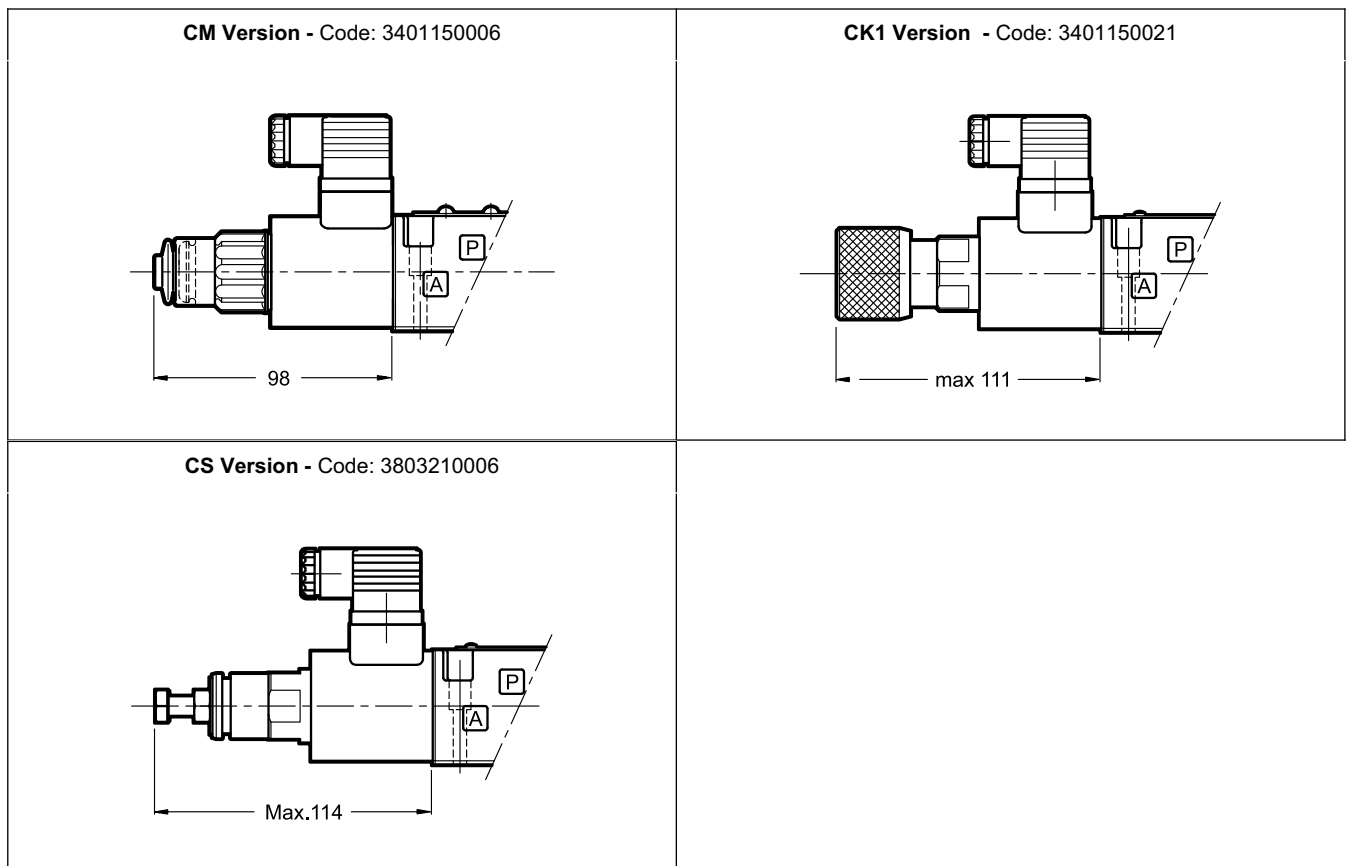

12 - HYDRAULIC FLUIDS

Use mineral oil-based hydraulic fluids HL or HM type, according to ISO 6743-4. For these fluids, use NBR seals. For fluids HFDR type (phosphate esters) use FPM seals (code V). For the use of other kinds of fluid such as HFA, HFB, HFC, please consult our technical department.

Using fluids at temperatures higher than 80 °C causes a faster degradation of the fluid and of the seals characteristics. The fluid must be preserved in its physical and chemical characteristics.

13 - INSTALLATION

DSE3G* valves can be installed in any position without impairing correct operation. Ensure that there is no air in the hydraulic circuit.

Valves are fixed by means of screws or tie rods on a lapped surface with planarity and roughness equal to or better than those indicated in the drawing.

If minimum values are not observed, fluid can easily leak between the valve and the mounting interface.

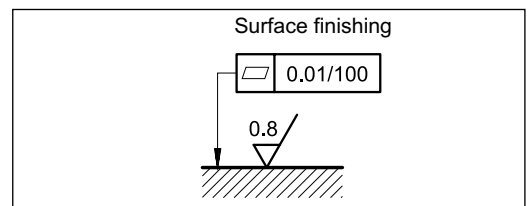



14 - ACCESSORIES

(to be ordered separately)

14.1 - Mating connectors

Mating connectors must be ordered separately. See catalogue 89 000.



For K11 and K16 versions we recommend the choice of a metal connector to avoid electromagnetic disturbances and to comply with EMC regulations on electromagnetic compatibility. If you opt for a plastic connector, make sure that it guarantees and maintains the IP and EMC protection characteristics of the valve.

14.2 - Mating connectors for fieldbus communication and for sensors.

Duplomatic offers spare parts to be wired and also ready-to-use cord sets. Please refer to cat. 89 000.

14.3 - Connection cable

The optimal wiring provides for 7 isolated conductors, with separate screen for the signal wires (command, monitor) and an overall screen.

Cross section for power supply:

- up to 20 m cable length : 1,0 mm²
- up to 40 m cable length : 1,5 mm² (IO-Link excluded)

Cross section for signals (command, monitor):

- 0,50 mm²

14.4 - Kit for start-up LINPC-USB

Device for service start-up and diagnostic, see catalogue 89 850.

15 - SUBPLATES

(see catalogue 51 000)

PMMD-AI3G rear ports
PMMD-AL3G side ports
Ports dimensions: P, T, A, B: 3/8" BSP