

# 2020

GENERAL CATALOGUE  
CATALOGO GENERALE

**HIGH PRESSURE INDUSTRIAL PUMPS**  
POMPE INDUSTRIALI AD ALTA PRESSIONE



**LCR**  
TEAM  
**Honda**  
MAJOR SPONSOR  
LCR HONDA TEAM

**COMET**



**Cal Crutchlow**

Comet major sponsor - LCR Honda Team



# ***Comet, a fast racing brand***

## **Comet, un brand che corre veloce**

*207 countries in the world, 400 million spectators per event: the MotoGP will enable Comet to obtain the exposure which the quality of its products deserves. For this reason, for the three-year period 2019-20-21 we will be Major Sponsors of the LCR Honda team and its rider Cal Crutchlow. This choice was not accidental. In fact, the LCR team brings together the Italian genius and foresight of its Team Principal Lucio Cecchinello with an international vision focused on technology and product innovation. Followed by a social fan base of 1,800,000 people, Cal Crutchlow together with the LCR HONDA team have shown themselves to work daily with passion, precision, speed and intuition, cultivating the exposure which will enable Comet to give its products global recognition. That's why we chose them as our allies: to be able to overcome the challenges of today and tomorrow.*

*207 Paesi nel mondo, 400 milioni di spettatori per singolo evento: la MotoGP permetterà a Comet di ottenere quella visibilità che la qualità dei suoi prodotti merita. Per questo motivo per il triennio 2019-20-21 saremo Major Sponsor del team LCR Honda e del suo pilota Cal Crutchlow. Questa scelta non è stata casuale, il team LCR infatti mette insieme il genio e la lungimiranza italiana nella figura del suo Team Principal Lucio Cecchinello con una visione Internazionale votata alla tecnologia e all'innovazione di prodotto. Seguiti da una social fan base di 1.800.000 persone, Cal Crutchlow insieme al team LCR HONDA dimostrano di lavorare quotidianamente con passione, precisione, velocità e intuizione coltivando quella visibilità che permetterà a Comet di dare ai suoi prodotti una riconoscibilità globale. Ecco perché li abbiamo scelti come alleati: per poter vincere le sfide di oggi e di domani.*

## LEGEND / LEGENDA / LEYENDA

	DIAMETER Diametro Diámetro		UNLOADER VALVE (BUILT-IN) Valvola di Regolazione (integrata) Válvula de Regulación (integrada)
	R.P.M. Giri/Min R.p.m.		UNLOADER VALVE (BOLT-ON) Valvola di Regolazione (flangiata) Válvula de Regulación (flangeada)
	MAX FLOW RATE Portata Max Caudal Máximo		SOLID SHAFT Albero Maschio Eje Macho
	MAX PRESSURE Pressione Max Presión Máxima		HOLLOW SHAFT FOR GAS ENGINES Albero Femmina per motori a benzina Eje Hembra para motores de gasolina
	MAX ABSORBED POWER Potenza Max assorbita Potencia absorbida Máxima		HOLLOW SHAFT FOR ELECTRICAL ENGINES Albero Femmina per motori elettrici Eje Hembra para motores electricos
	WEIGHT Peso Peso		HOLLOW SHAFT FOR HYDRAULIC MOTOR Albero Femmina per motori idraulici Eje Hembra para motores hidráulico
	MOTOR SIZE Grandezza motore Dimensionamiento del motor		CYLINDRICAL HOLLOW SHAFT Albero Cilindrico Femmina Eje Cilindrico Hembra
	GAS ENGINE Motore a scoppio Motor de explosión		SUCTION Aspirazione Aspiración
	MAX TEMPERATURE Temperatura massima Temperatura máxima		DELIVERY Mandata Manguera

<b>TotalStop TSR</b>	DEVICE THAT ENABLES THE AUTOMATIC SHUTDOWN OF MOTOR PUMP 15 SECONDS AFTER THE GUN IS CLOSED. Dispositivo di spegnimento automatico della motopompa dopo 15 secondi dalla chiusura della pistola. Dispositivo que permite de apagar automaticámente la motobomba después de 15 segundos desde el cierre de la pistola.
<b>TotalStop TSI</b>	DEVICE THAT ENABLES THE AUTOMATIC SHUTDOWN OF MOTOR PUMP IMMEDIATELY AFTER THE GUN IS CLOSED. Dispositivo di spegnimento automatico della motopompa contemporaneo alla chiusura della pistola. Dispositivo que permite de apagar automaticámente la motobomba contemporaneamente al cierre de la pistola.
<b>EASY-START</b>	DEVICE THAT REDUCES THE STARTING TORQUE OF THE MOTOR PUMP ASSURING THE START IN EVERY CONDITION. Dispositivo che riduce la coppia di spunto della motopompa in fase di avvio garantendone la partenza in ogni condizione. Dispositivo que reduce el par de arranque de la motobomba garantizando el funcionamiento en cualquier condición.

## PREMIUM



**EXCLUSIVE NO-OIL-LEAK SYSTEM**  
in the crankcase minimising wear of the piston oil seal (PATENTED)

**ESCLUSIVO SISTEMA DI TENUTA TRA CARTER E TESTATA**  
che impedisce l'ingresso di polvere e sporczia nella zona di scorrimento pistoni pur permettendo la fuoriuscita dell'acqua (BREVETTATO)

**EXCLUSIVO SISTEMA DE UNIÓN ENTRE CABEZA Y CUERPO DE LA BOMBA.**  
Previene la entrada de polvo y suciedad en la zona de trabajo de los pistones facilitando su movimiento (PATENTADO)



**EXCLUSIVE PACKING SYSTEM**  
New self lubricating double packing design with special bunatexile seals and bronze rings for an exceptional packing life.

**ESCLUSIVO SISTEMA DI TENUTE ACQUA AUTOLUBRIFICATO** con doppio pacco di guarnizioni in gomma tela rinforzate con anelli in teflon/bronzo per una eccezionale durata delle guarnizioni

**EXCLUSIVO SISTEMA DE SELLADO DEL AGUA AUTOLUBRICANTE** con doble paquete de sellos en tela de caucho reforzada con anillos de teflón/bronce para una excepcional duración



**EXCLUSIVE SEALING SYSTEM BETWEEN CRANKCASE AND PUMP HEAD** that prevents dust and dirt getting inside where the pistons work but letting water out (PATENTED)

**ESCLUSIVO SISTEMA DI TENUTA OLIO** nel carter che minimizza l'usura del paraolii pistoni (BREVETTATO)

**EXCLUSIVO SISTEMA DE SELLADO DE ACEITE** en el cárter que minimiza el desgaste del sello de aceite (PATENTADO)

# INDEX / INDICE / ÍNDICE

- 6 OPERATION AND COMPOSITION**  
FUNZIONAMENTO E COMPOSIZIONE  
FUNCIONAMIENTO Y COMPOSICIÓN
- 14 APPLICATIONS**  
APPLICAZIONI  
APLICACIONES
- 16 TRIPLEX PUMPS**  
POMPE A PISTONI TRIPLEX  
BOMBAS DE PISTONES TRIPLEX
- |                        |         |
|------------------------|---------|
| BWD-K                  | pag. 17 |
| AWD-K                  | pag. 19 |
| LW/LWS/LWR/LWD         | pag. 20 |
| LW-K/LWS-K/LWR-K/LWD-K | pag. 26 |
| DWD-K                  | pag. 30 |
| EWD                    | pag. 32 |
| EWD-K                  | pag. 34 |
| ZW/ZWR/ZWD             | pag. 36 |
| ZW-K/ZWD-K             | pag. 40 |
| FW2/FWS2/FWD2          | pag. 42 |
| RWN/RW/RWS             | pag. 47 |
| ETW/ETWS               | pag. 51 |
| TWN/TW/TWS             | pag. 52 |
| TW 500/TWS 500         | pag. 53 |
| TW 700/TWS 700         | pag. 54 |
- 55 PUMPS FOR HIGH TEMPERATURE WATER**  
POMPE PER ACQUA AD ELEVATA TEMPERATURA  
BOMBAS PARA AGUA A ALTA TEMPERATURA
- |            |         |
|------------|---------|
| FW2 Nickel | pag. 56 |
| ZW         | pag. 57 |
| RW/RWS     | pag. 58 |
| RW Nickel  | pag. 59 |
| TW         | pag. 60 |
| TW Nickel  | pag. 61 |
- 62 PUMPS FOR HYDRAULIC MOTORS**  
POMPE PER APPLICAZIONE DIRETTA  
A MOTORE IDRAULICO  
BOMBAS PARA APLICACIÓN DIRECTA  
EN MOTOR HIDRÁULICO
- |     |         |
|-----|---------|
| ZW  | pag. 63 |
| FW2 | pag. 64 |
| TW  | pag. 65 |
- 66 AXIAL PISTON PUMPS**  
POMPE A PISTONI ASSIALI  
BOMBAS DE PISTONES AXIALES
- |     |         |
|-----|---------|
| VRX | pag. 67 |
| BXD | pag. 69 |
| AXD | pag. 71 |
| CXD | pag. 73 |
- 75 MISTING PUMPS - LOW FLOW**  
POMPE PER EVAPORATORI A BASSA PORTATA  
BOMBAS PARA EVAPORADORES DE BAJO CAUDAL
- |        |         |
|--------|---------|
| LW/LWS | pag. 76 |
| AXS    | pag. 79 |
| BXS    | pag. 80 |
- 81 MOTOR PUMP UNITS WITH ELECTRIC MOTOR**  
GRUPPI MOTOPOMPA (TRIPLEX)  
CON MOTORE ELETTRICO  
GRUPOS MOTOBOMBA (TRIPLEX)  
CON MOTOR ELÉCTRICO
- |               |         |
|---------------|---------|
| MTP LWR-K 250 | pag. 82 |
| MTP LW-K 250  | pag. 83 |
| MTP ZW-K      | pag. 84 |
| MTP FW2       | pag. 85 |
| MTP RW        | pag. 86 |
| MTP TW        | pag. 87 |
| MPT TW 500    | pag. 88 |
- 89 MOTOR PUMP UNITS (AXIAL) WITH ELECTRIC MOTOR**  
GRUPPI MOTOPOMPA (ASSIALI)  
CON MOTORE ELETTRICO  
GRUPOS MOTOBOMBA (AXIALES)  
CON MOTOR ELÉCTRICO
- |         |         |
|---------|---------|
| MTP KSR | pag. 90 |
| MTP AXR | pag. 91 |
- 92 MOTOR PUMP UNITS FOR MISTING**  
GRUPPI MOTOPOMPA PER EVAPORATORI  
A BASSA PORTATA  
GRUPOS MOTOBOMBA PARA EVAPORADORES  
DE BAJO CAUDAL
- |                 |         |
|-----------------|---------|
| MTP LW Misting  | pag. 93 |
| MTP FW2 Misting | pag. 94 |
| MTP TW Misting  | pag. 95 |
| MTP KSR Misting | pag. 96 |
| MTP AX Misting  | pag. 97 |
- 98 MOTOR PUMP UNITS WITH HYDRAULIC MOTOR**  
GRUPPI MOTOPOMPA PER EVAPORATORI  
A BASSA PORTATA  
GRUPOS MOTOBOMBA PARA EVAPORADORES  
DE BAJO CAUDAL
- |              |          |
|--------------|----------|
| MTP HYDR ZW  | pag. 99  |
| MTP HYDR FW2 | pag. 100 |
| MTP HYDR TW  | pag. 101 |
- 103 MOTOR PUMP UNITS WITH GAS ENGINE**  
GRUPPI MOTOPOMPA CON MOTORE A SCOPPIO  
GRUPOS MOTOBOMBA CON MOTOR DE EXPLOSIÓN
- 104 PTO**  
PTO  
PTO
- 106 BOILER KIT**  
KIT CALDAIA  
KIT CALDERA
- 108 ACCESSORIES**  
ACCESSORI  
ACCESORIOS
- 117 CHARTS**  
TABELLE  
TABLAS

# COMET PLUNGER PUMPS - OPERATION AND COMPOSITION

## POMPE A PISTONI COMET - FUNZIONAMENTO E COMPOSIZIONE

## BOMBAS DE PISTONES COMET - FUNCIONAMIENTO Y COMPOSICIÓN



Comet plunger pumps fall into the category of reciprocating positive displacement plunger pumps, i.e., equipped with technical features whereby the flow of liquid occurs by virtue of changes in one or more capacities which, alternately, convey the liquid back and forth. The difference between maximum and minimum volume of the variable capacity represents the theoretical volume of the pumped liquid.

Comet plunger pumps are divided into two categories:

- 1) Inline (or Triplex) plunger pumps
- 2) Axial plunger pumps

Both types of pumps are essentially made up of two fundamental constructive elements, assembled together in a fixed way:

- the head, which contains the hydraulic part of the pump
- the crankcase, which contains the mechanical-kinematic part (oil bath).

The other main elements, common to both categories of pumps, are:

- the hydraulic seal system on the pistons, consisting of pumping pistons, rings and seals
- the suction and delivery valves

These parts are all located in the head

The main difference between the two types of plunger pumps (inline and axial) is constituted by the mechanical-kinematic part, which determines the reciprocating motion of the pistons.

### Inline (Triplex) plunger pump

The Comet inline (Triplex) plunger pump features three pumping elements, arranged along parallel axes lying on the same horizontal plane. Each of the above pumping elements consists

Le pompe a pistoni Comet rientrano nella categoria delle pompe volumetriche alternative a pistoni, cioè dotate di caratteristiche tecniche per cui lo scorrimento del liquido avviene in virtù delle variazioni di una o più capacità che, alternativamente, aspirano e mandano il liquido. La differenza fra volume massimo e minimo della capacità variabile rappresenta il volume teorico di liquido pompato.

Le pompe a pistoni Comet si suddividono in due categorie:

- 1) Pompe a pistoni in linea (o Triplex)
- 2) Pompe a pistoni assiali

Entrambi i tipi di pompe sono essenzialmente composti da due elementi costruttivi fondamentali, assemblati in modo fisso tra loro:

- la testata, che racchiude al suo interno la parte idraulica della pompa
- il carter, che racchiude al suo interno la parte meccanica-cinematica (in bagno d'olio).

Gli altri elementi principali, comuni ad entrambe le categorie di pompe, sono:

- il sistema di tenuta idraulica sui pistoni, costituito da pistoni pompanti, anelli e guarnizioni
- le valvole di aspirazione e mandata

Questi elementi sono tutti situati nella testata.

La differenza fondamentale tra i due tipi di pompe a pistoni (in linea e assiali) è costituita dalla parte meccanica-cinematica, che determina il movimento alternativo dei pistoni.

### Pompa a pistoni in linea (Triplex)

La pompa a pistoni in linea (Triplex) Comet è strutturata su tre elementi pompanti, disposti ad assi paralleli giacenti su uno stesso piano orizzontale. I suddetti elementi pompanti sono

Las bombas de pistones Comet forman parte de la categoría de bombas volumétricas alternativas de pistones, es decir, dotadas de características técnicas por lo cual el desplazamiento del líquido se produce en virtud de las variaciones de una o más capacidades, que aspiran e impulsan el líquido alternativamente. La diferencia entre volumen máximo y mínimo de la capacidad variable, representa el volumen teórico de líquido bombeado.

Las bombas de pistones Comet se subdividen en dos categorías:

- 1) Bombas de pistones en línea (o Triplex)
- 2) Bombas de pistones axiales

Ambos tipos de bombas están formados esencialmente por dos elementos constructivos fundamentales, ensamblados entre sí de modo fijo:

- el cabezal, que encierra en su interior la parte hidráulica de la bomba
- el cárter, que encierra en su interior la parte mecánica-cinemática (en baño de aceite).

Los demás elementos principales, comunes a ambas categorías de bombas, son:

- el sistema de estanqueidad hidráulica en los pistones, constituido por pistones bombeantes, anillos y juntas
- las válvulas de aspiración e impulsión

Todos estos elementos se encuentran ubicados en el cabezal

La diferencia fundamental entre los dos tipos de bombas de pistones (en línea y axiales) está constituida por la parte mecánica-cinemática, que determina el movimiento alternativo de los pistones.

### Bomba de pistones en línea (Triplex)

La bomba de pistones en línea (Triplex) Comet está estructurada en tres elementos bombeantes, dispuestos a lo largo de ejes que yacen en el

of a piston (made up of a “drive” section and a “pumping” section), driven in a reciprocating manner by a rod-crank system, which is responsible for the suction and pressure actions.

The pumping piston is of the “plunger” type, i.e., the pumped liquid sealing system is fixed, while the piston slides inside. The pumping elements are then driven by a shaft with three eccentrics offset by 120°. The shaft with three eccentrics is supported by two bearings and has one end protruding from the crankcase to get its motion from the motor driving the pump.

Each pumping element is made as described below.

The reciprocating motion of the drive piston is produced by the connecting rod through the piston pin; the connecting rod is in turn operated by one of the three eccentrics belonging to the shaft which transmits the motion to the pump..

To the drive piston is connected the pumping piston, which can be made with a ceramic bushing, fitted to the drive piston and retained by a nut, or by providing a ceramic insert section directly on the drive piston. The sealing system acts on the pumping piston to ensure the seal of the pumped liquid during the reciprocating pumping piston sliding.

un tratto “di guida” ed un tratto “pompante”), mosso in modo alternativo da un sistema biella-manovella, che è responsabile delle azioni di aspirazione e di pressione.

Il pistone pompante è di tipo “tuffante”, ovvero il sistema di tenuta del liquido pompato è fisso, mentre il pistone scorre al suo interno. Gli elementi pompanti sono quindi mossi da un albero a tre eccentrici sfasati tra loro di 120°. L'albero a tre eccentrici è supportato da due cuscinetti e ha una estremità che fuoriesce dal carter per prendere il moto dal motore che aziona la pompa.

Ogni elemento pompante è realizzato come di seguito descritto. Il moto alternativo del pistone di guida è dato dalla biella tramite lo spinotto, la quale a sua volta è azionata da uno dei tre eccentrici appartenente all'albero che fornisce il movimento alla pompa.

Al pistone di guida è collegato il pistone pompante, che può essere realizzato con una bussola, in materiale ceramico, applicata al pistone di guida e trattenuta da un dado, oppure realizzando un tratto di riporto ceramico direttamente sul pistone di guida. Sul pistone pompante agisce il sistema di tenuta, con la funzione di garantire la tenuta del liquido pompato durante lo scorrimento alternativo del pistone pompante.

mismo plano horizontal. Dichos elementos bombeantes están formados cada uno por un pistón (constituido por un tramo “de guía” y un tramo “bombeante”), movido en modo alternativo por un sistema biela-manivela, que es responsable de las acciones de aspiración y de presión.

La bomba de pistones prevé el sistema de estanqueidad del líquido bombeado de tipo fijo, mientras el pistón se desplaza en su interior. Por lo tanto, los elementos bombeantes son movidos por un eje de tres excéntricas desfasadas 120° entre sí. El eje de tres excéntricas está sostenido por dos rodamientos y tiene una extremidad que sobresale del cárter para tomar el movimiento del motor que acciona la bomba.

Cada elemento bombeante está realizado como se describe a continuación.

El movimiento alternativo del pistón de guía lo produce la biela a través del pasador, la cual es accionada al mismo tiempo por uno de los tres ejes excéntricos que pertenece al cigüeñal que proporciona el movimiento a la bomba.

Al pistón de guía está conectado el pistón bombeante, que se puede realizar con un casquillo, de material cerámico, aplicado al pistón de guía y sostenido por una tuerca, o bien realizando un tramo de aplicación cerámica directamente en el pistón deslizante. En el pistón bombeante interviene el sistema de estanqueidad, con la función de garantizar la estanqueidad del líquido bombeado durante el desplazamiento alternativo del pistón bombeante.

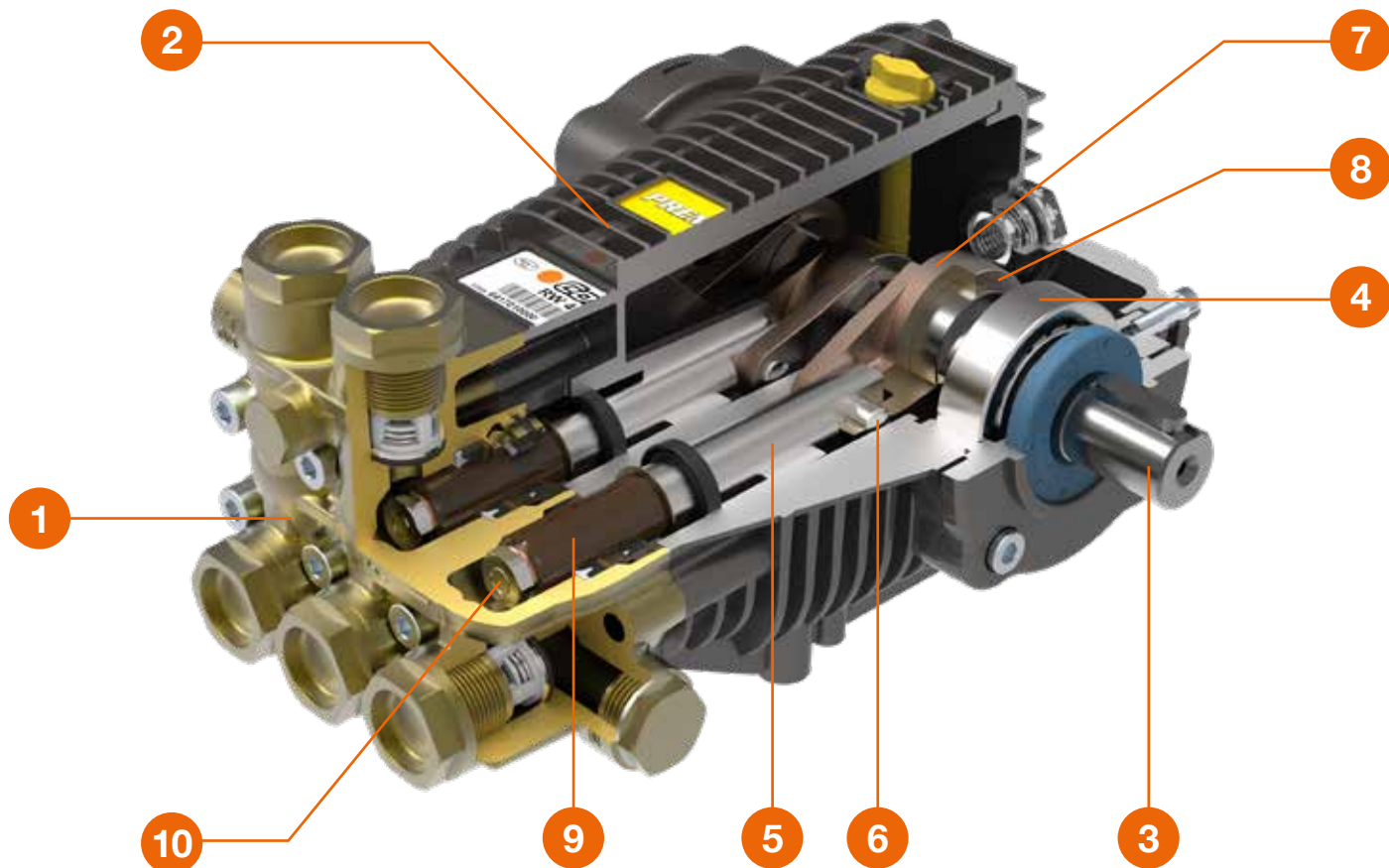

1. Head - 2. Crankcas - 3. Shaft  
4. Bearings - 5. Drive piston  
6. Pin - 7. Connecting rod - 8. Eccentric  
9. Bushing (Pumping piston) - 10. Nut

1. Testata - 2. Carter - 3. Albero  
4. Cuscinetti - 5. Pistone di guida  
6. Spinotto - 7. Biella - 8. Eccentrico  
9. Bussola (Pistone pompante) - 10. Dado

1. Cabezal - 2. Cárte - 3. Cigüeña  
4. Rodamientos - 5. Pistón de guía  
6. Pasador - 7. Biela - 8. Excéntrica  
9. Casquillo (Pistón bombeante) - 10. Tuerca

### Axial plunger pump

The Comet axial plunger pump always features three pumping elements, arranged in parallel axes in this case on three equidistant generators of a geometric cylinder.

Each of the above pumping elements consists of a piston (made up, in this case too, of a “drive” section and a “pumping” section) driven in a reciprocating manner by a tilted-plate thrust system and by a spring return system. The pumping piston is always of the “plunger” type, i.e., the pumped liquid sealing system is fixed, while the piston slides inside.

The plate, which is tilted with respect to the piston axis, provides the thrust to the drive piston by means of a coupling attachment (or sheet) which acts on the end of the piston itself by the interposition of an axial bearing between the coupling attachment and plate. The plate is integral with the shaft that drives the pump and which is coaxial with the three pistons. The shaft is in turn supported by a thrust bearing, housed in the pump support, and has one extremity protruding from the support to get its motion from the motor driving the pump.

The drive piston is connected to the pumping piston, which is made with a ceramic insert section or with a special surface treatment performed directly on the drive piston.

The sealing system acts on the pumping piston to ensure the seal of the pumped liquid during the reciprocating pumping piston sliding.

### Pompa a pistoni assiali

La pompa a pistoni assiali Comet è strutturata sempre su tre elementi pompanti, disposti ad assi paralleli posizionati in questo caso su tre generatrici equidistanti di un cilindro geometrico. I suddetti elementi pompanti sono composti ognuno da un pistone (costituito, anche in questo caso, da un tratto “di guida” ed un tratto “pompante”), mosso in modo alternativo da un sistema di spinta a piattello inclinato e da un sistema di ritorno a molla. Il pistone pompante è sempre di tipo “tuffante”, ovvero il sistema di tenuta del liquido pompato è fisso, mentre il pistone scorre al suo interno.

Il piattello, inclinato rispetto all’asse dei pistoni, fornisce la spinta al pistone di guida tramite una ralla (o piastra), che agisce sull’estremità del pistone stesso con l’interposizione di un cuscinetto assiale tra ralla e piattello. Il piattello è solidale con l’albero che fornisce il moto alla pompa e che è coassiale con i tre pistoni. L’albero è a sua volta supportato da un cuscinetto reggispira, alloggiato nel supporto pompa, e ha una estremità che fuoriesce dal Supporto per prendere il moto dal motore che aziona la pompa.

Al pistone di guida è collegato il pistone pompante, che è realizzato con un tratto di riporto ceramico o con uno speciale trattamento superficiale effettuato direttamente sul pistone di guida. Sul pistone pompante agisce il sistema di tenuta, con la funzione di garantire la tenuta del liquido pompato durante lo scorrimento alternativo del pistone pompante.

### Bomba de pistones axiales

La bomba de pistones axiales Comet está siempre estructurada en tres elementos bombeantes, dispuestos paralelamente en este caso posicionados sobre tres generadores equidistantes de un cilindro geométrico.

Dichos elementos bombeantes están formados cada uno por un pistón (también en este caso, constituido por un tramo “de guía” y un tramo “bombeante”), movido en modo alternativo por un sistema de empuje de platillo inclinado y por un sistema de retorno por muelle. Le bomba de pistones prevé siempre el sistema de estanqueidad del líquido bombeado de tipo fijo, mientras el pistón se desplaza en su interior.

El platillo, inclinado respecto al eje de los pistones, da el empuje al pistón de guía a través de un tejuelo (o chapa), que interviene en la extremidad del pistón con la interposición de un rodamiento axial entre el tejuelo y el platillo. El platillo es solidario al cigüeñal que proporciona el movimiento a la bomba y que es coaxial con los tres pistones. El cigüeñal a su vez está sostenido por un cojinete de empuje, alojado en el soporte bomba, y tiene una extremidad que sobresale del Soporte para tomar el movimiento del motor que acciona la bomba.

Al pistón de guía está conectado el pistón bombeante, que está realizado con un tramo de aplicación cerámica o con un tratamiento superficial especial realizado directamente en el pistón de guía. En el pistón bombeante interviene el sistema de estanqueidad, cuya función es garantizar la estanqueidad del líquido bombeado durante el desplazamiento alternativo del pistón bombeante.

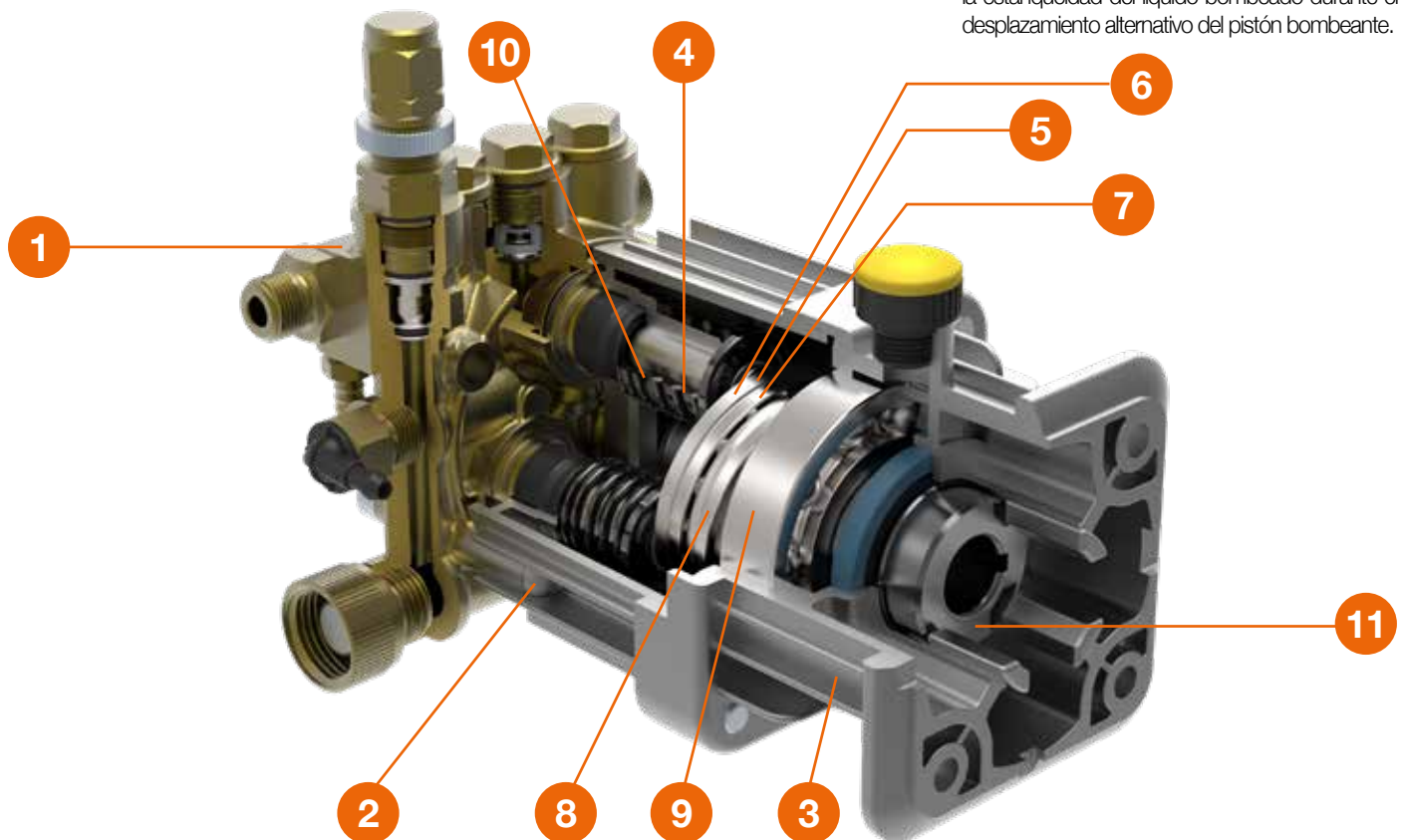

- 1. Head - 2. Crankcase - 3. Pump support
- 4. Piston - 5. Piston end - 6. Coupling attachment
- 7. Plate axial bearing
- 8. Eccentric plate - 9. Thrust bearing
- 10. Piston return spring - 11. Pump shaft

- 1. Testata - 2. Carter - 3. Supporto pompa
- 4. Pistone - 5. Estremità pistone - 6. Ralla
- 7. Cuscinetto assiale del piattello
- 8. Piattello eccentrico - 9. Cuscinetto reggispira
- 10. Molla ritorno pistone - 11. Albero pompa

- 1. Cabezal - 2. Cárter - 3. Soporte bomba
- 4. Pistón - 5. Extremidad pistón - 6. Tejuelo
- 7. Rodamiento axial del platillo
- 8. Platillo excéntrico - 9. Cojinete de empuje
- 10. Muelle de retorno pistón - 11. Cigüeñal bomba



### Sealing system on pumping pistons

The sealing system, on both types of pumps, is essentially made up of two gaskets: a high-pressure gasket, with the function of sealing the pumped liquid, and a low-pressure gasket, with the function of sealing any liquid leaking out of the high-pressure gasket.

The two gaskets are spaced apart, with the interposition of an annular chamber which is in communication, via a connecting hole, with the intake manifold. This constructive configuration has two functions:

- to create a recovery tank for the possible leakage of liquid out of the high-pressure gasket, preventing this from reaching the outside
- to ensure the presence of liquid between the two gaskets, including in the absence of leakage out of the high-pressure gasket; this keeps the low-pressure gasket wet and therefore prevents it from overheating in the absence of lubrication.

Other accessory gasket parts are generally also a part of the sealing system such as pressure rings, gasket support rings and anti-extrusion rings. The presence and type of construction of these accessory elements are linked to several factors, among which the most important are the type of gasket adopted and the pump working pressure.

### Sistema di tenuta sui pistoni pompanti

Il sistema di tenuta, su entrambi i tipi di pompe, è essenzialmente costituito da due guarnizioni: una guarnizione di alta pressione, con la funzione di tenuta del liquido pompato, ed una guarnizione di bassa pressione, con la funzione di tenuta del liquido eventualmente trafilato dalla guarnizione di alta pressione.

Le due guarnizioni sono distanziate tra loro, con l'interposizione di una camera anulare che è in comunicazione, tramite un foro di collegamento, con il collettore di aspirazione. Le funzioni di questa configurazione costruttiva sono due:

- creare un serbatoio di recupero dell'eventuale trafileamento di liquido dalla guarnizione di alta pressione, impedendo che esso fuoriesca all'esterno
- garantire la presenza di liquido tra le due guarnizioni, anche in assenza di trafileamento dalla guarnizione di alta pressione; ciò per mantenere bagnata la guarnizione di bassa pressione ed impedire pertanto che essa si surriscaldi per assenza di lubrificazione.

Fanno generalmente parte del Sistema di tenuta anche altri elementi accessori alle guarnizioni, precisamente gli anelli di pressione, gli anelli di sostegno delle guarnizioni e gli anelli antiestrusione. La presenza e la forma costruttiva di questi elementi accessori sono legate a diversi fattori, fra i quali i più importanti sono da considerarsi il tipo di guarnizione adottata e la pressione di lavoro della pompa.

### Sistema de estanqueidad sobre los pistones bombeantes

El sistema de estanqueidad, en ambos tipos de bombas, está constituido esencialmente por dos juntas: una junta de alta presión, con la función de estanqueidad del líquido bombeado, y una junta de baja presión, con la función de estanqueidad del líquido que pierde la junta de alta presión.

Las dos juntas están separadas entre sí, interponiendo una cámara anular que está en comunicación, a través de un orificio de conexión, con el colector de aspiración. Las funciones de esta configuración constructiva son dos:

- crear un depósito de recuperación de la eventual pérdida de líquido de la junta de alta presión, impidiendo que éste salga al exterior
- garantizar la presencia de líquido entre las dos juntas, también en caso de inexistencia de pérdidas de la junta de alta presión; esto para mantener mojada la junta de baja presión y, por lo tanto, impedir que ésta se caliente excesivamente debido a la ausencia de lubricación.

Generalmente forman parte del Sistema de estanqueidad también otros elementos accesorios a las juntas, concretamente los anillos de presión, los anillos de sujeción de las juntas y los anillos anti-extrusión. La presencia y la forma constructiva de estos elementos accesorios están vinculados a distintos factores, entre los cuales, los más importantes a tener en cuenta son el tipo de junta adoptada y la presión de trabajo de la bomba.

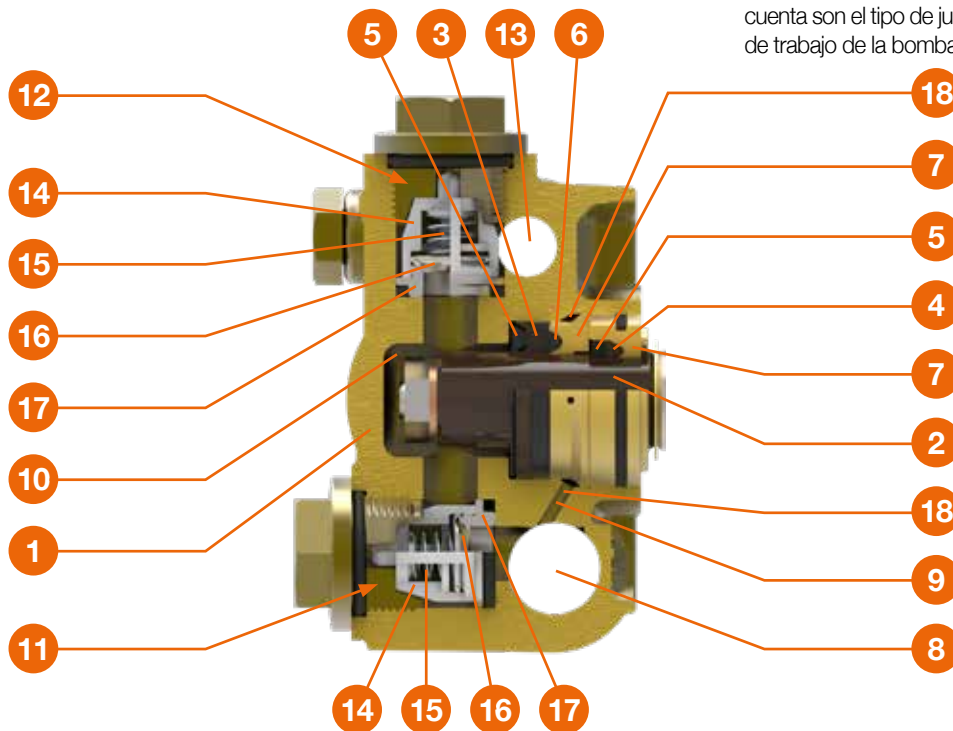

1. Head - 2. Pumping Piston
3. High-pressure Gasket
4. Low-pressure Gasket
5. Pressure rings - 6. Anti-extrusion ring
7. Gasket support rings
8. Intake manifold - 9. Connecting hole
10. Pumping chamber - 11. Suction valve
12. Delivery valve - 13. Delivery manifold
14. Valve cage - 15. Valve spring - 16. Valve plate
17. Valve seat - 18. Annular chamber

1. Testata - 2. Pistone pompante
3. Guarnizione di alta pressione
4. Guarnizione di bassa pressione
5. Anelli di pressione - 6. Anello antiestrusione
7. Anelli di sostegno guarnizioni
8. Collettore di aspirazione - 9. Foro di collegamento
10. Camera di pompaggio - 11. Valvola di aspirazione
12. Valvola di mandata - 13. Collettore di mandata
14. Gabbia valvola - 15. Molla valvola - 16. Piattello valvola
17. Sede valvola - 18. Camera anulare

1. Cabezal - 2. Pistón bombeante
3. Junta de alta presión
4. Junta de baja presión
5. Anillos de presión - 6. Anillo anti-extrusión
7. Anillos de sujeción juntas
8. Colector de aspiración - 9. Orificio de conexión
10. Cámara de bombeo - 11. Válvula de aspiración
12. Válvula de impulsión - 13. Colector de impulsión
14. Jaula válvula - 15. Muelle válvula - 16. Platinillo válvula
17. Alojamiento válvula - 18. Cámara anular

## Suction and delivery valves

Each pumping element of both types of pumps (inline pistons and axial pistons) is provided with a suction valve and a delivery valve, arranged in the opposite direction the one to the other. The purpose of these valves is to intercept the liquid and permit the pumping action in the working cycle corresponding to the shaft rotation.

The operation of the valves is of the automatic type, i.e., opening and the closing are determined by the pressure difference of the fluid on the valve plate, held in position by the contrasting force of a spring.

A complete rotation of the pump shaft causes an intake phase (piston return to bottom dead centre) and a delivery phase (advancement of the piston to the upper dead centre) for each pumping element. In the intake phase the liquid is sucked through the suction valve into the pumping chamber formed in the head, while the delivery valve is closed. In the delivery phase, the liquid is pushed out of the pumping chamber through the delivery valve while the suction valve is closed.

The pumping elements are connected transversely to each other by means of intake and delivery manifolds obtained in the head.

## Valvole di aspirazione e mandata

Ogni elemento pompante di entrambi i tipi di pompe (a pistoncini in linea e a pistoncini assiali) è corredato di una valvola di aspirazione e di una valvola di mandata, disposte in senso opposto l'una rispetto all'altra. La funzione delle valvole è quella di intercettare il liquido permettendo l'azione pompante nel ciclo di lavoro corrispondente alla rotazione dell'albero.

Il funzionamento delle valvole è di tipo automatico, cioè l'apertura e la chiusura sono determinate dalla differenza di pressione del fluido sul piattello della valvola, tenuto in posizione dalla forza di contrasto di una molla.

Una rotazione completa dell'albero pompa determina una fase di aspirazione (richiamo del pistone fino al punto morto inferiore) ed una fase di mandata (avanzamento del pistone fino al punto morto superiore) per ogni elemento pompante. Nella fase di aspirazione il liquido viene aspirato attraverso la valvola di aspirazione nella camera di pompaggio ricavata nella testata, mentre la valvola di mandata è chiusa. Nella fase di mandata, il liquido viene spinto fuori dalla camera di pompaggio attraverso la valvola di mandata, mentre la valvola di aspirazione è chiusa.

Gli elementi pompanti sono collegati trasversalmente tra loro dai collettori di aspirazione e mandata ricavati sulla testata.

## Válvulas de aspiración e impulsión

Cada elemento bombeante de ambos tipos de bombas (de pistones en línea y de pistones axiales) va acompañado de una válvula de aspiración y de una válvula de impulsión, entre sí y colocadas en sentido opuesto una respecto a la otra. La función de las válvulas consiste en interceptar el líquido permitiendo la acción bombeante en el ciclo de trabajo correspondiente a la rotación del cigüeñal.

El funcionamiento de las válvulas es de tipo automático, es decir, la apertura y el cierre están determinados por la diferencia de presión del fluido en el platillo de la válvula, mantenido en posición por la fuerza de contraste de un muelle.

Una rotación completa del cigüeñal de la bomba determina una fase de aspiración (retorno del pistón hasta el punto muerto inferior) y otra de impulsión (avance del pistón hasta el punto muerto superior) por cada elemento bombeante. En la fase de aspiración, el líquido se aspira a través de la válvula de aspiración en la cámara de bombeo obtenida en el cabezal, mientras la válvula de impulsión está cerrada. En la fase de impulsión, el líquido es empujado fuera de la cámara de bombeo a través de la válvula de impulsión, mientras la válvula de aspiración está cerrada.

Los elementos bombeantes están conectados transversalmente entre sí por los colectores de aspiración e impulsión obtenidos en el cabezal.

## Efficiency

The efficiency of the Plunger pumps is identified by the following physical quantities:

- Flow rate
- Pressure
- Power

The **flow rate** is the volume pumped in the unit of time and it is possible to distinguish a theoretical Flow Rate **Qt** (flow rate which can theoretically be supplied by the pump) and an actual flow rate **Qe** (actual flow rate supplied by the pump). The Flow Rate is normally expressed with the unit of measurement **l/min** (metric system) or **gpm** (system used in English-speaking countries). The Flow Rate **Qt** for the three-piston **inline** pumps is calculated using the following formula (valid for metric units):

## Prestazioni

Le prestazioni delle Pompe a Pistoni sono individuate dalle seguenti grandezze fisiche:

- Portata
- Pressione
- Potenza.

La **portata** è il volume pompato nell'unità di tempo e si può distinguere una Portata teorica **Qt** (portata teoricamente fornibile dalla pompa) e una portata effettiva **Qe** (portata effettivamente fornita dalla pompa). La Portata si esprime normalmente con le unità di misura **l/min** (sistema metrico) o **gpm** (sistema anglosassone). La Portata **Qt** per le pompe a tre pistoncini **in linea** si calcola con la seguente formula (valida per le unità metriche):

$$Q_t \text{ [l/min]} = \frac{3 \times \pi \times D^2 \text{ [mm]} \times e \text{ [mm]} \times n \text{ [1/min]}}{2 \times 10^6}$$

## Prestaciones

Las prestaciones de las Bombas de Pistones se identifican por las magnitudes físicas siguientes:

- Caudal
- Presión
- Potencia

El **caudal** es el volumen bombeado en la unidad de tiempo, pudiéndose distinguir un Caudal teórico **Qt** (caudal teóricamente suministrado por la bomba) y un caudal efectivo **Qe** (caudal efectivamente suministrado por la bomba). El Caudal normalmente se expresa con las unidades de medida **l/min** (sistema métrico) o **gpm** (sistema anglosajón).

El Caudal **Qt** para las bombas de tres pistoncini **en línea** se calcula con la fórmula siguiente (válida para las unidades métricas):

Wherein:

**D** [mm] = piston diameter  
**e** [mm] = pump shaft eccentric  
**n** [rpm] = rotation speed

The Flow Rate **Qt** for the three-piston axial pumps is instead calculated using the following formula (valid for metric units):

In cui:

**D** [mm] = diametro pistone  
**e** [mm] = eccentricità albero pompa  
**n** [giri/min] = velocità di rotazione

La Portata **Qt** per le pompe a tre pistoni **assiali** si calcola invece con la seguente formula (valida per le unità metriche):

Donde:

**D** [mm] = diámetro pistón  
**e** [mm] = excentricidad cigüeñal bomba  
**n** [rpm] = velocidad de rotación

En cambio, el Caudal **Qt** para las bombas de tres pistones **axiales** se calcula con la fórmula siguiente (válida para las unidades métricas):

$$Q_t \text{ [l/min]} = \frac{3 \times \pi \times D^2 \text{ [mm]} \times i \text{ [mm]} \times \tan \alpha \times n \text{ [1/min]}}{2 \times 10^6}$$

Wherein:

**D** [mm] = piston diameter  
**i** [mm] = piston centre distance (distance between pump axis and a piston axis)  
**α** [rad] = pump plate inclination angle  
**n** [rpm] = rotation speed

From the above figures in metric units, the flow rate can be obtained in units used in English-speaking countries with the formula:

In cui:

**D** [mm] = diametro pistone  
**i** [mm] = interasse pistoni (distanza tra asse della pompa e asse di un pistone)  
**α** [rad] = angolo inclinazione piattello pompa  
**n** [giri/min] = velocità di rotazione

Dai suddetti valori in unità metriche, si ricava la portata in unità anglosassoni con la formula:

Donde:

**D** [mm] = diámetro pistón  
**i** [mm] = entre eje pistones (distancia entre el eje de la bomba y el eje de un pistón)  
**α** [rad] = ángulo de inclinación platillo bomba  
**n** [rpm] = velocidad de rotación

De dichos valores en unidades métricas, se obtiene el caudal en unidades anglosajonas con la fórmula:

$$Q_t \text{ [gpm]} = \frac{Q_t \text{ [l/min]}}{3,785412}$$

The ratio between the two flow rates, theoretical and actual, defines the volumetric efficiency  $\eta_v$  of the pump:

Il rapporto tra le due portate, teorica ed effettiva, definisce il rendimento volumetrico  $\eta_v$  della pompa:

La relación entre los dos caudales, teórico y efectivo, define el rendimiento volumétrico  $\eta_v$  de la bomba:

$$\eta_v = \frac{Q_e}{Q_t}$$

The flow rate figures which appear in the catalogue efficiencies are those of the actual flow rate **Qe**.

The flow rate of positive-displacement plunger pumps is proportionate to the rotation speed and tends to be independent from the delivery pressure, though it does tend to drop as the latter increases.

The **pressure** is the maximum value possible in the pump head in operating conditions.

It must however be realized that positive-displacement plunger pumps do not intrinsically develop pressure during their movement, but move liquid by virtue of their construction features, described in the previous chapter. If however, downstream of the pump, in the delivery circuit, there is an obstacle (e.g., a nozzle), the pressure is generated in the pump head needed to ensure the pump flow rate is able to cross the encountered obstacle.

I valori di portata che compaiono nelle prestazioni a catalogo sono quelli della portata effettiva **Qe**.

La portata delle pompe volumetriche a pistoni è proporzionale alla velocità di rotazione ed è tendenzialmente indipendente dalla pressione di mandata, tendendo però a diminuire all'aumentare di quest'ultima.

La **pressione** è il valore massimo che si può avere nella testata della pompa in condizioni di lavoro. Qui occorre precisare che le pompe volumetriche a pistoni non sviluppano intrinsecamente pressione nel loro movimento, ma spostano liquido in virtù delle loro caratteristiche costruttive come descritto nel capitolo precedente. Se però a valle della pompa, nel circuito di mandata, è presente un'ostruzione (ad esempio un ugello), si genera nella testata della pompa la pressione che è necessaria affinché la portata della pompa possa attraversare l'ostruzione incontrata.

Los valores de caudal que aparecen en las prestaciones en el catálogo son los del caudal efectivo **Qe**.

El caudal de las bombas volumétricas de pistones es proporcional a la velocidad de rotación y es tendencialmente independiente de la presión de impulsión, tendiendo a disminuir conforme aumenta ésta última.

La **presión** es el valor máximo que se puede obtener en el cabezal de la bomba en condiciones de trabajo. Aquí es necesario precisar que las bombas volumétricas de pistones no desarrollan intrínsecamente presión en su movimiento, pero desplazan líquido en virtud de sus características constructivas, tal como se describe en el capítulo anterior. Pero si detrás de la bomba, en el circuito de impulsión, hay una obstrucción (por ejemplo, una boquilla), en el cabezal de la bomba se genera la presión necesaria de manera que la bomba pueda atravesar la obstrucción encontrada.

It is therefore necessary for the delivery circuit to feature a maximum pressure valve which does not permit the creation of a pressure above maximum allowed pressure, established according to pump resistance characteristics. In fact, if the above obstacle is complete (e.g., the total closure of the delivery circuit), pressure would tend to become too great with consequent breakage of the head. The fitting of an adjustable by-pass valve also permits setting a determinate pressure value according to operating requirements.

Pressure is expressed in metric units, in **bar**, in **MPa**, and, in English-speaking countries in **PSI**. The ratios between the above units of measurement are the following:

E' pertanto necessario che nel circuito di mandata sia presente una valvola di massima pressione che non permetta l'instaurarsi di una pressione superiore a quella massima, stabilita in base alle caratteristiche di resistenza della pompa. Infatti se l'ostruzione di cui sopra dovesse essere completa (ad esempio la chiusura totale del circuito di mandata), la pressione tenderebbe ad un valore infinitamente grande con la conseguente rottura della testata. L'inserimento di una valvola di by-pass regolabile permette inoltre di stabilire un determinato valore di pressione in base alle esigenze di utilizzo.

La Pressione si esprime, in unità metriche, in **bar**, in **MPa**, e in unità anglosassoni in **PSI**. Le relazioni tra le suddette unità di misura sono le seguenti:

Por lo tanto, es necesario que en el circuito de impulsión se encuentre una válvula de máxima presión que no permita que se instaure una presión superior a la máxima, establecida en base a las características de resistencia de la bomba. Efectivamente, si la obstrucción citada arriba fuera total (por ejemplo, el cierre total del circuito de impulsión), la presión tendría un valor infinitamente grande con la consiguiente rotura del cabezal. La introducción de una válvula de by-pass regulable, permite además establecer un determinado valor de presión en función de las exigencias de uso.

La Presión se expresa en unidades métricas, en **bar**, en **MPa**, y en unidades del sistema anglosajón en **PSI**. Las relaciones entre dichas unidades de medida son las siguientes:

$$P \text{ [MPa]} = P \text{ [bar]} \times 0,1$$

$$P \text{ [PSI]} = P \text{ [bar]} \times 14,50326$$

The working **power** output **Nu** of a pump is the energy supplied to the pumped liquid in the unit of time, while the absorbed power **Na** is the energy, in the unit of time, which the pump requires from its energy source (electric motor, thermal motor, hydraulic motor, etc.) to perform the required pumping operation. The units of measurement used to express Power are **kW**, **CV** and **HP**.

The working power output **Nu** is calculated according to the formula:

La **potenza** utile **Nu** di una pompa è l'energia fornita al liquido pompato nell'unità di tempo, mentre la potenza assorbita **Na** è l'energia nell'unità di tempo che la pompa richiede alla sua fonte di energia (motore elettrico, termico, oleodinamico, etc.) per effettuare il lavoro di pompaggio richiesto. Le unità di misura utilizzate per esprimere la Potenza sono **kW**, **CV** e **HP**.

La potenza utile **Nu** si calcola con la formula:

La **potencia** útil **Nu** de una bomba es la energía suministrada al líquido bombeado en la unidad de tiempo, mientras la potencia absorbida **Na** es la energía en la unidad de tiempo que la bomba pide a su fuente de energía (motor eléctrico, térmico, oleodinámico, etc.) para realizar el trabajo de bombeo requerido. Las unidades de medida utilizadas para expresar la Potencia son **kW**, **CV** y **HP**.

La potencia útil **Nu** se calcula con la fórmula:

$$Nu \text{ [kW]} = \frac{Q_e \text{ [l/min]} \times P \text{ [bar]}}{600}$$

The ratios between the other power units of measurement are the following:

Le relazioni tra le altre unità di misura della potenza sono le seguenti:

Las relaciones entre las demás unidades de medida de la potencia son las siguientes:

$$Nu \text{ [HP]} = Nu \text{ [kW]} \times 1,341$$

$$Nu \text{ [CV]} = Nu \text{ [kW]} \times 1,360$$

The absorbed power is tied to the working power output with the ratio:

La potenza assorbita è legata alla potenza utile con la relazione:

La potencia absorbida está vinculada a la potencia útil con la relación:

$$Na \text{ [kW]} = \frac{Nu \text{ [kW]}}{\eta_t}$$

wherein  $\eta_t$  is the total efficiency of the pump produced by the three efficiencies  $\eta_v$  (volumetric),  $\eta_m$  (mechanical) and  $\eta_i$  (hydraulic).

Volumetric efficiency  $\eta_v$  normally takes on values from 0.85 to 0.95. Lower values are found for axial plunger pumps and with an increase in rotation speed, while the highest values are found with inline plunger pumps and low rotation speeds.

Hydraulic efficiency  $\eta_i$  expresses the losses due to the resistances opposed to the flow through the head and for high pressures, characteristic of plunger pumps, it features values close to the unit.

Mechanical efficiency  $\eta_m$  expresses the power losses in the mechanical-kinematic part: this is higher in inline plunger pumps (0.94÷0.96) and lower in axial plunger pumps (0.90÷0.92).

On the basis of the above, the total efficiency  $\eta_t$  is therefore lowest (0.78÷0.80) in axial plunger pumps with high rotation speed (3400 rpm) and highest (0.90÷0.92) in inline plunger pumps with low rotation speed (1000÷1400 rpm).

The power values which appear in the catalogue efficiencies are those of the absorbed power **Na**. The absorbed power in positive-displacement plunger pumps, with constant rotation speed (and therefore constant flow rate) is proportionate to pressure.

in cui  $\eta_t$  è il rendimento totale della pompa prodotto dei tre rendimenti  $\eta_v$  (volumetrico),  $\eta_m$  (meccanico) e  $\eta_i$  (idraulico).

Il rendimento volumetrico  $\eta_v$  assume normalmente valori da 0,85 a 0,95. I valori inferiori si hanno per le pompe a pistoni assiali e con l'aumento della velocità di rotazione, mentre i valori più alti si hanno nelle pompe a pistoni in linea e con basse velocità di rotazione.

Il rendimento idraulico  $\eta_i$  esprime le perdite per le resistenze opposte al flusso attraverso la testata e per le pressioni elevate, tipiche delle pompe a pistoni, ha valori prossimi all'unità.

Il rendimento meccanico  $\eta_m$  esprime le perdite di potenza nella parte meccanica-cinematica: ha valori superiori nelle pompe a pistoni in linea (0,94÷0,96) e valori inferiori nelle pompe a pistoni assiali (0,90÷0,92).

In base a quanto sopra, il rendimento totale  $\eta_t$  assume quindi i valori più bassi (0,78÷0,80) nelle pompe a pistoni assiali ad alta velocità di rotazione (3400 giri/min) e i valori più alti (0,90÷0,92) nelle pompe a pistoni in linea a bassa velocità di rotazione (1000÷1400 giri/min).

I valori di potenza che compaiono nelle prestazioni a catalogo sono quelli della potenza assorbita **Na**. La potenza assorbita nelle pompe volumetriche a pistoni, con velocità di rotazione costante (e quindi a portata costante) è proporzionale alla pressione.

donde  $\eta_t$  es el rendimiento total de la bomba producido de los tres rendimientos  $\eta_v$  (volumétrico),  $\eta_m$  (mecánico) e  $\eta_i$  (hidráulico).

El rendimiento volumétrico  $\eta_v$  normalmente asume valores de 0,85 a 0,95. Los valores inferiores se obtienen para las bombas de pistones axiales y con el aumento de la velocidad de rotación, mientras los valores más altos se obtienen en las bombas de pistones en línea y con bajas velocidades de rotación.

El rendimiento hidráulico  $\eta_i$  expresa las pérdidas para las resistencias opuestas al flujo a través del cabezal y para las presiones elevadas, típicas de las bombas de pistones, tiene valores próximos a la unidad.

El rendimiento mecánico  $\eta_m$  expresa las pérdidas de potencia en la parte mecánica-cinematica: tiene valores superiores en las bombas de pistones en línea (0,94÷0,96) y valores inferiores en las bombas de pistones axiales (0,90÷0,92).

En base a lo anteriormente citado, el rendimiento total  $\eta_t$  asume los valores más bajos (0,78÷0,80) en las bombas de pistones axiales a alta velocidad de rotación (3400 rpm) y los valores más altos (0,90÷0,92) en las bombas de pistones en línea a baja velocidad de rotación (1000÷1400 rpm).

Los valores de potencia que aparecen en las prestaciones en el catálogo son aquellos de la potencia absorbida **Na**. La potencia absorbida en las bombas volumétricas de pistones, con velocidad de rotación constante (y por tanto con caudal constante) es proporcional a la presión.



**APPLICATIONS FOR HIGH PRESSURE PISTON PUMPS**  
 APPLICAZIONI PER POMPE A PISTONI AD ALTA PRESSIONE  
 APLICACIONES PARA BOMBAS DE PISTÓN DE ALTA PRESIÓN

	bar [psi]													
	18 [250]	35 [500]	55 [800]	70 [1000]	85 [1200]	105 [1500]	125 [1800]	140 [2000]	155 [2500]	210 [3000]	245 [3500]	275 [4000]	345 [5000]	500 [7250]
<b>CLEANING / PULIZIA / LIMPIAMIENTO</b>														
Aircraft Engine		✓	✓											
Battery			✓	✓										
Buses				✓	✓	✓	✓	✓	✓	✓	✓	✓		
Cars			✓	✓	✓	✓								
Carpet	✓	✓	✓	✓	✓									
Ceramic Tile Vat							✓	✓	✓					
Compressor Castings		✓	✓											
CIP Multiple Station			✓	✓	✓	✓	✓	✓						
Filter		✓	✓	✓										
Food Plant Sanitizing		✓	✓	✓	✓	✓	✓	✓						
Freight Trucks						✓	✓	✓						
Heat Exchanger Tube Coils	✓	✓												
Heavy Equipment						✓	✓	✓	✓	✓	✓	✓	✓	
Hog Cleaning/Sanitizing			✓	✓	✓									
Live Wire Insulator		✓	✓	✓										
Locomotive				✓	✓	✓	✓	✓	✓	✓	✓	✓	✓	✓
Moss/Mildew Removal			✓	✓	✓									
Offshore Platform								✓	✓	✓	✓	✓	✓	✓
Oil Storage Tank								✓	✓	✓	✓			
Potatoes			✓	✓	✓									
Sander Belts									✓	✓	✓			
Screen/Filter		✓	✓	✓	✓	✓	✓							
Seal Gland Flushing					✓	✓	✓	✓						
Sponge Vat							✓	✓	✓					
Vegetables		✓	✓											

<b>HYDROSTATIC / IDROSTATICA / IDROSTÁTICA</b>														
BOP		✓	✓	✓	✓	✓	✓	✓	✓	✓	✓	✓	✓	✓
Hydraulic Power HWBF - 95/5		✓	✓	✓	✓	✓	✓	✓	✓	✓	✓	✓	✓	✓
Jockey Pumps				✓	✓	✓	✓	✓	✓	✓	✓	✓	✓	✓
Pipe/Tube Testing		✓	✓	✓	✓	✓	✓	✓	✓	✓	✓	✓	✓	✓
Textile Water Extraction	✓	✓	✓											

<b>LIQUID INJECTION / INIEZIONE DI LIQUIDI / INYECCIÓN DE LIQUIDOS</b>														
Ag Fertilizer/Herbicides						✓	✓	✓	✓	✓	✓	✓		
Beer Exciting	✓	✓												
Boiler Feed	✓	✓	✓	✓	✓									
Diesel/Fuel Oil									✓	✓	✓	✓	✓	
Golf Course Aeration									✓	✓	✓	✓	✓	
Brine Oil Waste Water			✓	✓	✓	✓	✓	✓	✓	✓				
Oil Field, Glycol Injection				✓	✓	✓	✓	✓						
Oil Field, Methanol						✓	✓	✓	✓	✓	✓	✓	✓	
Oil Field, Water/Glucose						✓	✓	✓	✓	✓	✓	✓	✓	
Pesticide				✓	✓	✓								
Secondary Recovery/Well Stimulation				✓	✓	✓	✓	✓	✓	✓	✓	✓	✓	
Undersea Diving Vessel			✓	✓										

<b>METERING / DOSAGGIO / DOSIFICACIÓN</b>														
Crude Oil Transfer		✓	✓	✓	✓									
Homogenizing			✓	✓	✓	✓	✓	✓	✓	✓	✓	✓	✓	✓
Machine Tool Coolant Flushing						✓	✓	✓	✓	✓				

	bar [psi]													
	18 [250]	35 [500]	55 [800]	70 [1000]	85 [1200]	105 [1500]	125 [1800]	140 [2000]	155 [2500]	210 [3000]	245 [3500]	275 [4000]	345 [5000]	500 [7250]
<b>MISTING / UMIDIFICAZIONE / NEBULIZACIÓN</b>														
Agriculture		✓	✓	✓	✓	✓								
Chicken/Turkey		✓	✓	✓	✓	✓								
Coal Dust Suppression			✓	✓	✓									
Dairy Barn Sanitation		✓	✓	✓	✓	✓								
Equestrian		✓	✓	✓	✓	✓								
Evaporative Cooling				✓	✓	✓	✓	✓	✓	✓				
Greenhouse		✓	✓	✓	✓	✓								
Lumber Conditioning		✓	✓	✓	✓	✓								
Odor Control		✓	✓	✓										
Temperature Control		✓	✓	✓	✓	✓								
Turbine Cooling						✓	✓	✓	✓	✓				

<b>PROCESSING / PROCESSO / PROCESO</b>														
Chemical			✓	✓	✓	✓	✓	✓						
Chicken/Turkey Deboning						✓	✓	✓	✓					
Crude Petroleum Transfer		✓	✓	✓	✓									
Ham Deboning						✓	✓	✓						
Liquid CO2		✓	✓	✓	✓	✓	✓	✓	✓					
Saltwater Reverse Osmosis-Desalination		✓	✓	✓	✓	✓								

<b>SPRAYING / IRRORAZIONE / PULVERIZACIÓN</b>														
Fire Protection System			✓	✓	✓									
Row Crop	✓	✓	✓	✓										

<b>SURFACE TREATMENTS / TRATTAMENTO DELLE SUPERFICI / TRATAMIENTO DE SUPERFICIES</b>														
Cedar Siding Restoration							✓	✓	✓					
Exposed Aggregate								✓	✓	✓				
Gypsum Removal									✓	✓				
Label Removal				✓	✓	✓	✓	✓	✓	✓				
Metal Casting Flushing		✓	✓	✓	✓									
Paint Removal							✓	✓	✓	✓	✓	✓	✓	✓
Paint and Solder Removal										✓	✓	✓	✓	✓
Paper/Plastic/Tin Laser Cutting								✓	✓	✓	✓	✓	✓	✓
Plastic Flash Removal									✓	✓	✓	✓	✓	
Phosphatizing		✓	✓	✓	✓									

<b>WATER-JETTING/BLASTING / GETTO D'ACQUA / CHORRO DE AGUA</b>														
Cement Truck, Hopper, Hearth, Floors										✓	✓	✓	✓	✓
Cleaning Sewer Pipe						✓	✓	✓	✓	✓	✓	✓	✓	✓
Drain Line Tubes							✓	✓	✓	✓	✓	✓	✓	✓
Drilling Paraffin/Crude Residues										✓	✓	✓	✓	✓
Graffiti Removal										✓	✓	✓	✓	✓
Mill Scale, Slag Removal												✓	✓	✓
Mixers, Reactors, Evaporators												✓	✓	✓
Oak Debarking										✓	✓	✓	✓	
Pharmaceutical Residue										✓	✓	✓	✓	✓
Presses, Valves, Vessels						✓	✓	✓	✓	✓	✓	✓	✓	✓
Pulp and Paper Residue										✓	✓	✓	✓	✓
Runway Rubber Removal											✓	✓	✓	✓
Ship Hull Rust, Barnacle Removal												✓	✓	✓
Underground Trenching										✓	✓	✓	✓	✓
Wet Sandblasting					✓	✓	✓	✓	✓	✓	✓	✓	✓	✓



# TRIPLEX PUMPS

POMPE A PISTONI TRIPLEX

BOMBAS DE PISTONES TRIPLEX

---

All models are supplied with brass head.  
Standard versions with p.t.o on right hand side, left side on request.  
**Other flow / pressure combinations are available on request .**

Tutti i modelli sono forniti con testata in ottone.  
Le versioni standard hanno la presa di forza sul lato destro, a richiesta sul lato sinistro.  
**Altre combinazioni di portata e pressione sono disponibili su richiesta.**

Todos los modelos están disponibles con cabeza de latón.  
Las versiones estándar tienen la toma de fuerza en el lado derecho, bajo pedido en el lado izquierdo.  
**Otras combinaciones de caudal y presión están disponibles bajo pedido.**

# Triplex





# BWD-K



HOLLOW SHAFT Ø 3/4" > ALBERO FEMMINA Ø 3/4" > EJE HEMBRA Ø 3/4"

Code Codice Codigo	Model Modello Modelo	Version											
			"	rpm	l/min	US gpm	bar	psi	Mpa	HP	kW	kg	lb
6521 0150	BWD-K 2527	G	3/4	3400	9,8	2,5	186	2700	18,6	5,0	3,7	6,0	13,3
6521 0250	BWD-K 3020	G	3/4	3400	11,3	3,0	138	2000	13,8	4,3	3,2	6,0	13,3
6521 0350	BWD-K 3027	G	3/4	3400	11,3	3,0	186	2700	18,6	5,8	4,3	6,0	13,3

## SAE J 609 A

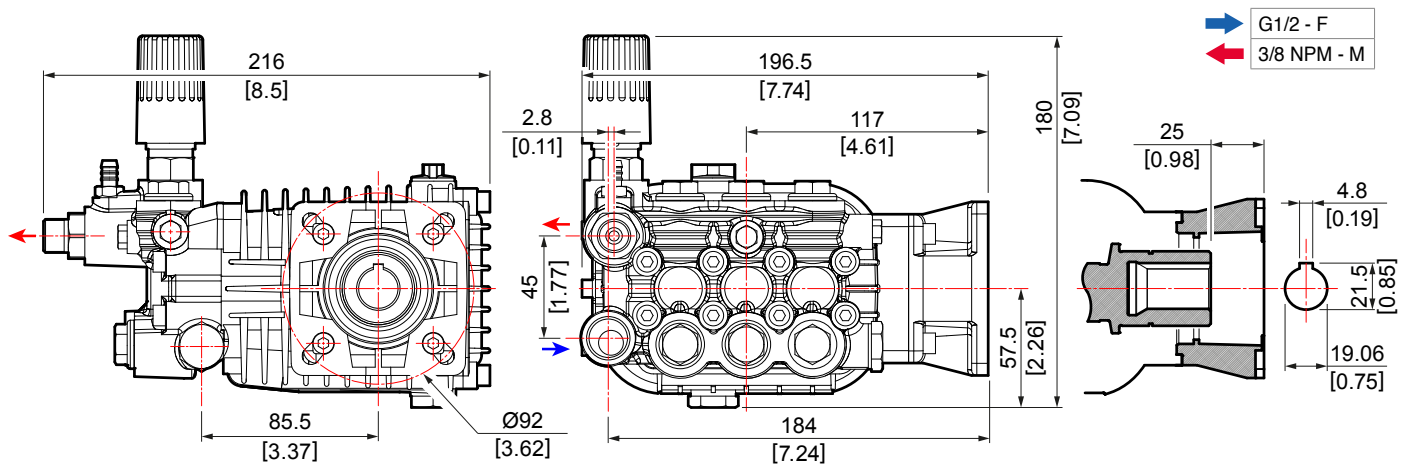



# BWD-K



HOLLOW SHAFT Ø 5/8" › ALBERO FEMMINA Ø 5/8" › EJE HEMBRA Ø 5/8"

Code Codice Codigo	Model Modello Modelo	Version											
			“	rpm	l/min	US gpm	bar	psi	Mpa	HP	kW	kg	lb
6521 0450	BWD-K 2020	E	5/8	3400	7,1	1,9	138	2000	13,8	2,7	2,0	6,0	13,3
6521 0251	BWD-K 3020	E	5/8	3400	10,0	2,7	138	2000	13,8	3,7	2,7	6,0	13,3

## NEMA 56 C

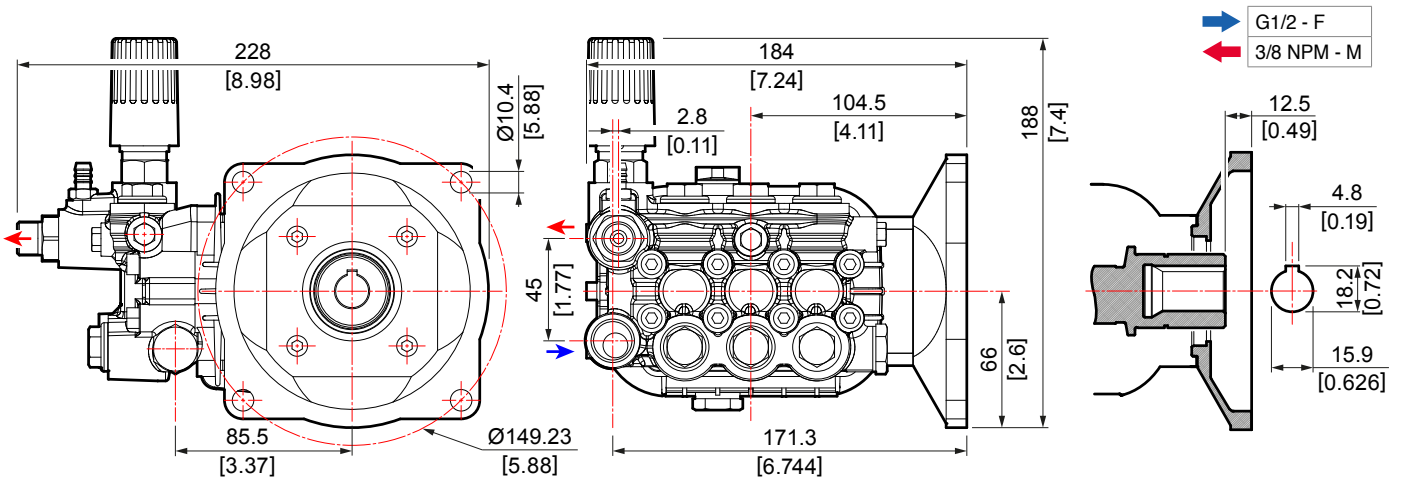



# AWD-K



HOLLOW SHAFT Ø 1" › ALBERO FEMMINA Ø 1" › EJE HEMBRA Ø 1"

Code Codice Codigo	Model Modello Modelo	Version	Ø	RPM	Hand	Pressure	Power	Weight					
			"	rpm	l/min	US gpm	bar	psi	Mpa	HP	kW	kg	lb
6520 0150	AWD-K 3030	G	1	3400	11,3	3,0	207	3000	20,7	6,4	4,7	6,5	14,4
6520 0250	AWD-K 3530	G	1	3400	13,1	3,5	207	3000	20,7	7,4	5,5	6,5	14,4
6520 0350	AWD-K 4030	G	1	3400	15,0	4,0	207	3000	20,7	7,5	5,5	6,5	14,4
6520 0450	AWD-K 4036	G	1	3400	15,0	4,0	248	3600	24,8	10,2	7,5	6,5	14,4

## SAE J 609 B

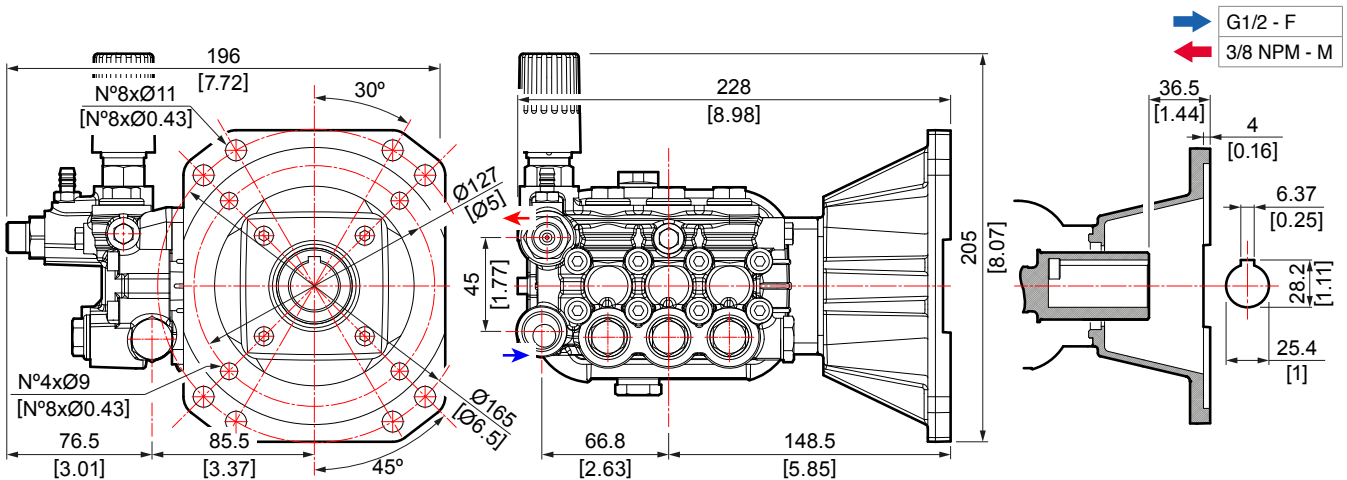

**LW**

**S** | Ø24 mm

**LWS**



ON REQUEST › SU RICHIESTA › BAJO PEDIDO



SOLID SHAFT Ø 24 mm › ALBERO MASCHIO Ø 24 mm › EJE MACHO Ø 24 mm

Code Codice Codigo	Model Modello Modelo	Version											
			mm	rpm	l/min	US gpm	bar	psi	Mpa	HP	kW	kg	lb
6300 0502	LW 2020	S	24	1450	8,0	2,1	138	2000	13,8	3,0	2,2	6,1	13,4
6300 0900	LW 2520	S	24	1450	10,0	2,6	138	2000	13,8	3,6	2,7	6,1	13,4
6300 0208	LW 3016	S	24	1450	11,2	3,0	110	1600	11,0	3,0	2,2	4,8	10,6
6300 0303	LW 3020	S	24	1450	11,2	3,0	138	2000	13,8	4,0	3,0	6,1	13,4
6300 0700	LW 3025	S	24	1450	11,2	3,0	172	2500	17,2	5,0	3,7	6,1	13,4
6300 0606	LW 3513	S	24	1450	13,4	3,5	90	1300	9,0	3,0	2,2	4,8	10,6
6300 0403	LW 3517	S	24	1450	13,4	3,5	117	1700	11,7	4,0	3,0	6,1	13,4
6300 0800	LW 3525	S	24	1450	13,4	3,5	172	2500	17,2	5,5	4,0	6,1	13,4
6301 0101	LWS 2020	S	24	1750	8,4	2,2	138	2000	13,8	3,0	2,2	6,1	13,4
6301 0502	LWS 3015	S	24	1750	12,2	3,2	103	1500	10,3	3,0	2,2	6,1	13,4
6301 0601	LWS 3020	S	24	1750	11,9	3,1	138	2000	13,8	4,0	3,0	6,1	13,4
6301 1300	LWS 3025	S	24	1750	12,3	3,2	172	2500	17,2	5,0	3,7	6,1	13,4
6301 1201	LWS 3525	S	24	1750	13,6	3,6	172	2500	17,2	5,5	4,0	6,1	13,4
6301 1400	LWS 4020	S	24	1750	16,1	4,2	138	2000	13,8	5,5	4,0	6,1	13,4

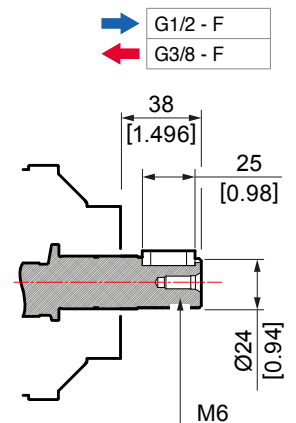
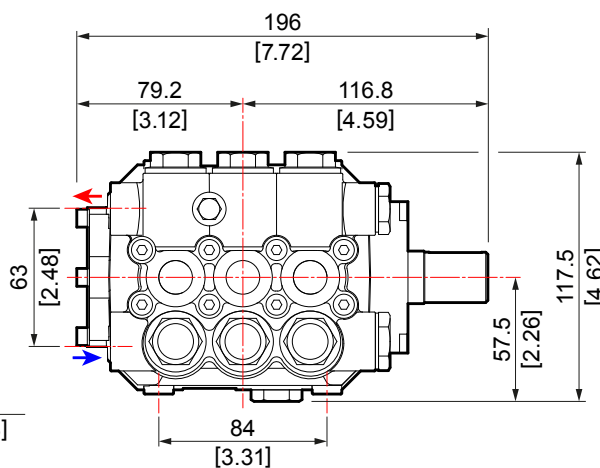
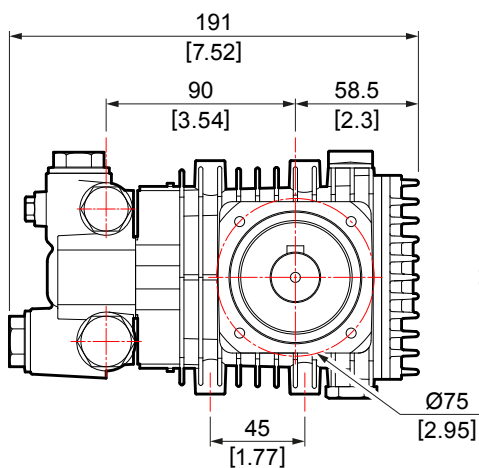



ON REQUEST › SU RICHIESTA › BAJO PEDIDO



HOLLOW SHAFT Ø 20 mm › ALBERO FEMMINA Ø 20 mm › EJE HEMBRA Ø 20 mm

Code Codice Codigo	Model Modello Modelo	Version											
			mm	rpm	l/min	US gpm	bar	psi	Mpa	HP	kW	kg	lb
▲ 6301 2000	LWS 3022	G	20	1750	11,2	3,0	152	2200	15,2	4,0	3,0	6,1	13,4
● 6301 2002	LWS 3022	G	20	1750	11,2	3,0	152	2200	15,2	4,0	3,0	6,1	13,4
● 6301 1304	LWS 3025	G	20	1750	11,2	3,0	172	2500	17,2	5,0	3,7	6,1	13,4
▲ 6301 1500	LWS 3514	G	20	1750	13,4	3,5	100	1450	10,0	3,4	2,5	6,1	13,4
▲ 6301 2100	LWS 3520	G	20	1750	13,4	3,5	138	2000	13,8	5,0	3,7	6,1	13,4
● 6301 1206	LWS 3525	G	20	1750	13,4	3,5	172	2500	17,2	5,5	4,0	6,1	13,4

P.T.O. on left hand side - Presa di forza sul lato sinistro - Toma de fuerza en el lado izquierdo.

\* Versions shaft G Ø18 mm available on request - Versioni albero G Ø18 mm disponibili su richiesta - Versiones eje G Ø18 mm disponibles bajo pedido.

### SPECIAL FLANGE (MITSUBISHI)

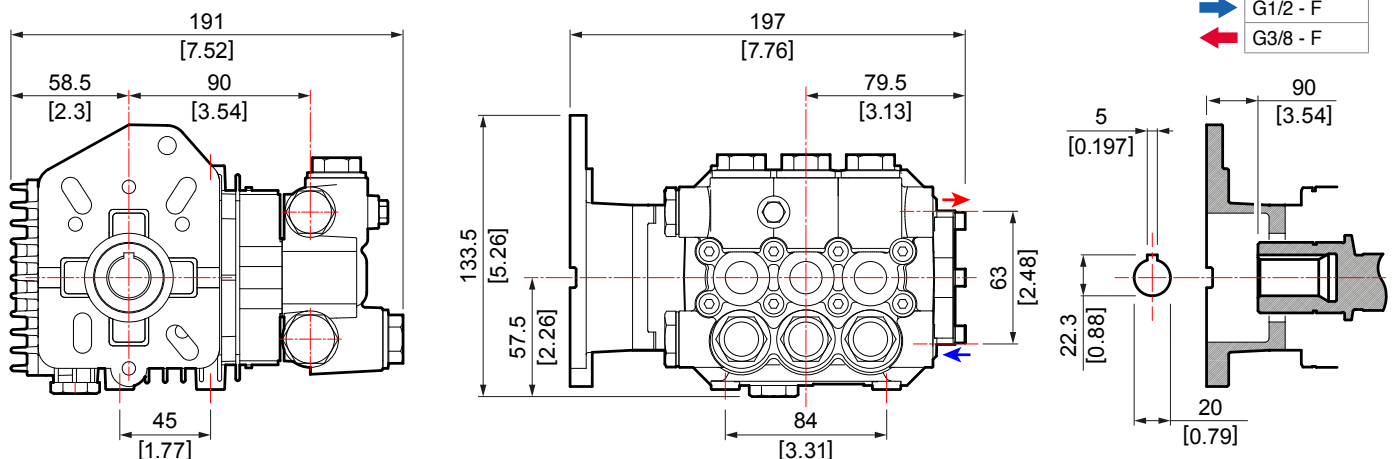

▲ For Honda motor - Per motore Honda - Para motor Honda.  
 ● For Mitsubishi motor - Per motore Mitsubishi - Para motor Mitsubishi

Contact us for other special flange drawings. / I disegni delle altre flange speciali sono disponibili su richiesta. / Contactar para los dibujos de las otras bridas especiales.



# LWD



ON REQUEST › SU RICHIESTA › BAJO PEDIDO



HOLLOW SHAFT Ø 3/4" › ALBERO FEMMINA Ø 3/4" › EJE HEMBRA Ø 3/4"

Code Codice Codigo	Model Modello Modelo	Version	Ø	RPM	l/min	US gpm	Pressure			Power		Weight	
			"	rpm			bar	psi	Mpa	HP	kW	kg	lb
6303 0104	LWD 2020	G	3/4	3400	8,2	2,2	138	2000	13,8	3,0	2,2	6,1	13,4
6303 1600	LWD 2520	G	3/4	3400	9,4	2,5	138	2000	13,8	3,6	2,7	5,9	13,0
6303 1700	LWD 2525	G	3/4	3400	9,4	2,5	172	2500	17,2	4,5	3,4	5,9	13,0
6303 0508	LWD 3020	G	3/4	3400	11,3	3,0	138	2000	13,8	4,0	3,0	5,9	13,0
6303 0701	LWD 3025	G	3/4	3400	11,3	3,0	172	2500	17,2	5,0	3,7	5,9	13,0
6303 1200	LWD 3515	G	3/4	3400	13,0	3,4	103	1500	10,3	3,5	2,6	5,9	13,0
6303 0802	LWD 3522	G	3/4	3400	13,0	3,4	152	2200	15,2	5,0	3,7	5,9	13,0

### SAE J 609 A

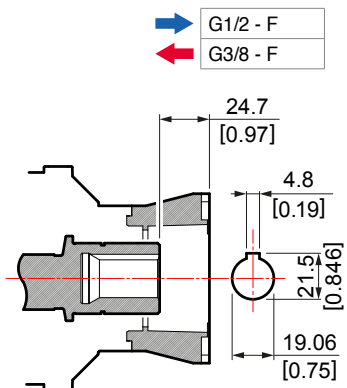
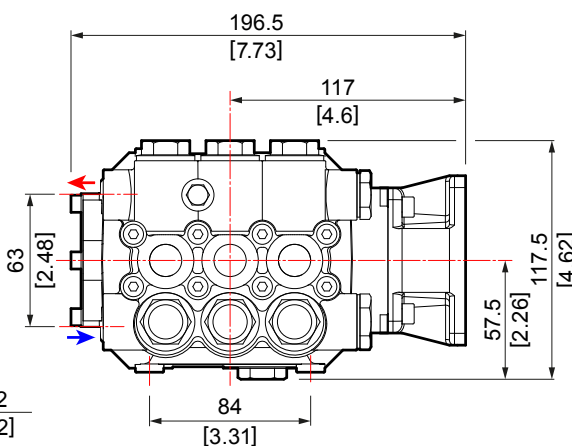
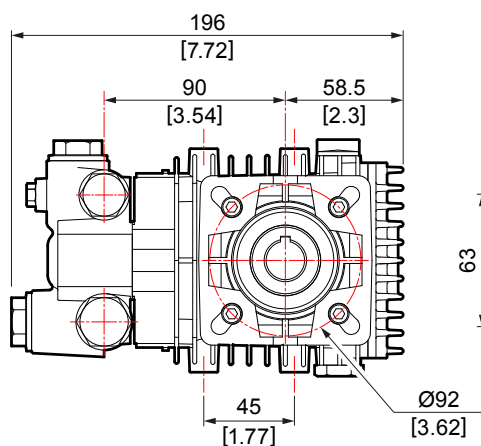



ON REQUEST › SU RICHIESTA › BAJO PEDIDO



HOLLOW SHAFT Ø 28 mm › ALBERO FEMMINA Ø 28 mm › EJE HEMBRA Ø 28 mm

Code Codice Codigo	Model Modello Modelo	Version											
			mm	rpm	l/min	US gpm	bar	psi	Mpa	HP	kW	kg	lb
6300 2900	LW 1626	E	28	1450	6,1	1,6	180	2600	18,0	2,7	2,0	6,5	14,4
6300 3000	LW 2022	E	28	1450	8,0	2,1	152	2200	15,2	3,0	2,2	6,5	14,4
6300 3100	LW 2516	E	28	1450	9,4	2,5	110	1600	11,0	2,8	2,1	6,5	14,4
6300 3200	LW 2518	E	28	1450	9,4	2,5	124	1800	12,4	3,1	2,3	6,5	14,4
6300 1100	LW 2520	E	28	1450	9,4	2,5	138	2000	13,8	3,5	2,6	6,5	14,4
6300 0312	LW 3020	E	28	1450	11,5	3,0	138	2000	13,8	3,9	2,9	6,5	14,4
6300 0612	LW 3522	E	28	1450	13,0	3,4	152	2200	15,2	5,1	3,8	6,5	14,4

MEC 110-112

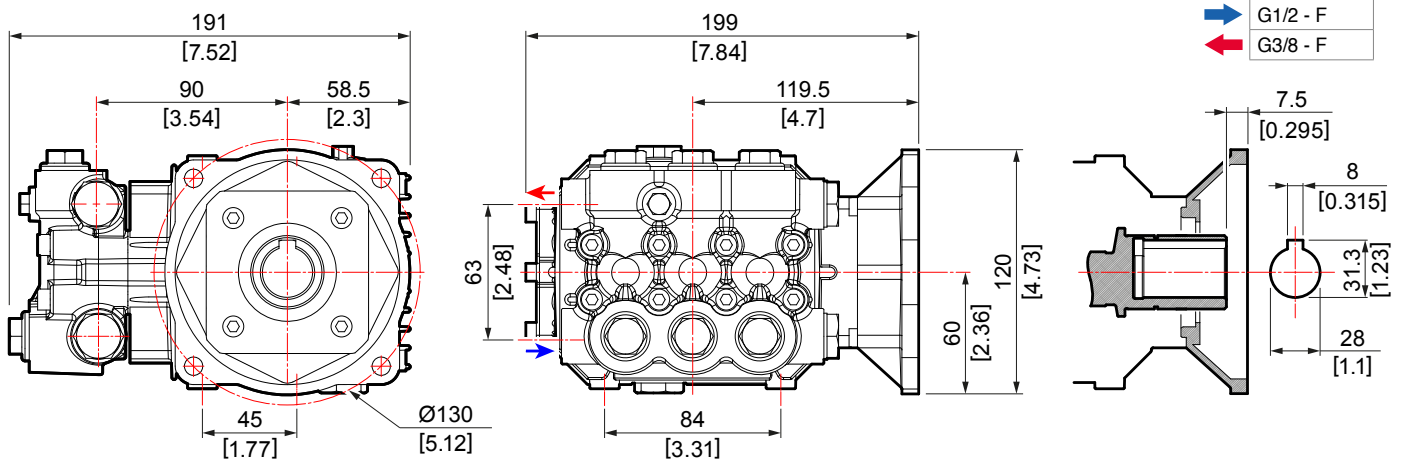



**LW**

**E** | Ø 24 mm



**LWR**



ON REQUEST › SU RICHIESTA › BAJO PEDIDO



HOLLOW SHAFT Ø 24 mm › ALBERO FEMMINA Ø 24 mm › EJE HEMBRA Ø 24 mm

Code Codice Codigo	Model Modello Modelo	Version											
			mm	rpm	l/min	US gpm	bar	psi	Mpa	HP	kW	kg	lb
* 6300 0605	LW 3513	E	24	1450	13,4	3,5	90	1300	9,0	3,0	2,2	4,8	10,6
6300 0607	LW 3513	E	24	1450	13,4	3,5	90	1300	9,0	3,0	2,2	4,8	10,6
6302 0403	LWR 3020	E	24	2800	10,8	2,7	138	2000	13,8	4,0	3,0	6,1	13,4

**MEC 90 B3-B14**

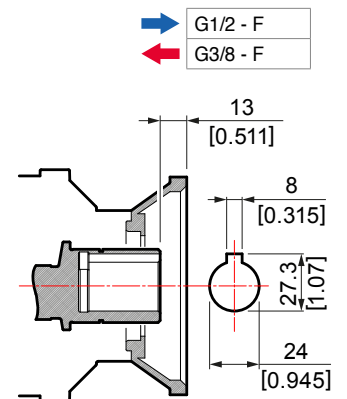
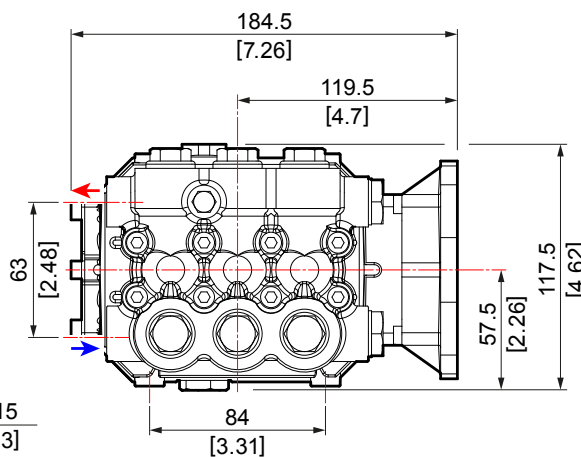
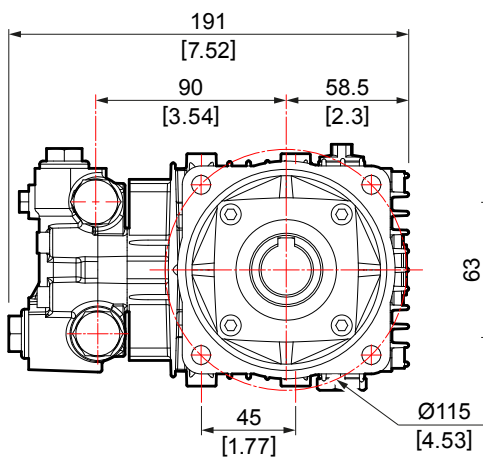

The models marked with \* are supplied with aluminum head. / I modelli contrassegnati con \* sono forniti con testata in alluminio. / Los modelos marcados con \* están disponibles con cabeza de aluminio.



**LWS**

**E** | Ø 5/8"

**LWD**



ON REQUEST › SU RICHIESTA › BAJO PEDIDO



HOLLOW SHAFT Ø 5/8" › ALBERO FEMMINA Ø 5/8" › EJE HEMBRA Ø 5/8"

Code Codice Codigo	Model Modello Modelo	Version											
			"	rpm	l/min	US gpm	bar	psi	Mpa	HP	kW	kg	lb
6301 0303	LWS 2015	E	5/8	1750	8,4	2,2	103	1500	10,3	2,0	1,5	5,9	13,0
6301 0102	LWS 2020	E	5/8	1750	8,4	2,2	138	2000	13,8	3,0	2,2	6,1	13,4
6301 0407	LWS 3010	E	5/8	1750	12,2	3,2	69	1000	6,9	2,0	1,5	4,7	10,4
6301 0604	LWS 3020	E	5/8	1750	11,9	3,1	138	2000	13,8	4,0	3,0	6,1	13,4
6301 0602	LWS 3520	E	5/8	1750	13,4	3,5	138	2000	13,8	5,0	3,7	6,1	13,4
6303 0207	LWD 2015	E	5/8	3400	8,2	2,2	103	1500	10,3	2,0	1,5	4,7	10,4
6303 0105	LWD 2020	E	5/8	3400	8,2	2,2	138	2000	13,8	3,0	2,2	5,9	13,0
6303 0509	LWD 3020	E	5/8	3400	11,3	3,0	138	2000	13,8	4,0	3,0	5,9	13,0
6303 0806	LWD 3522	E	5/8	3400	13,0	3,4	152	2200	15,2	5,0	3,7	5,9	13,0

**NEMA 56 C**

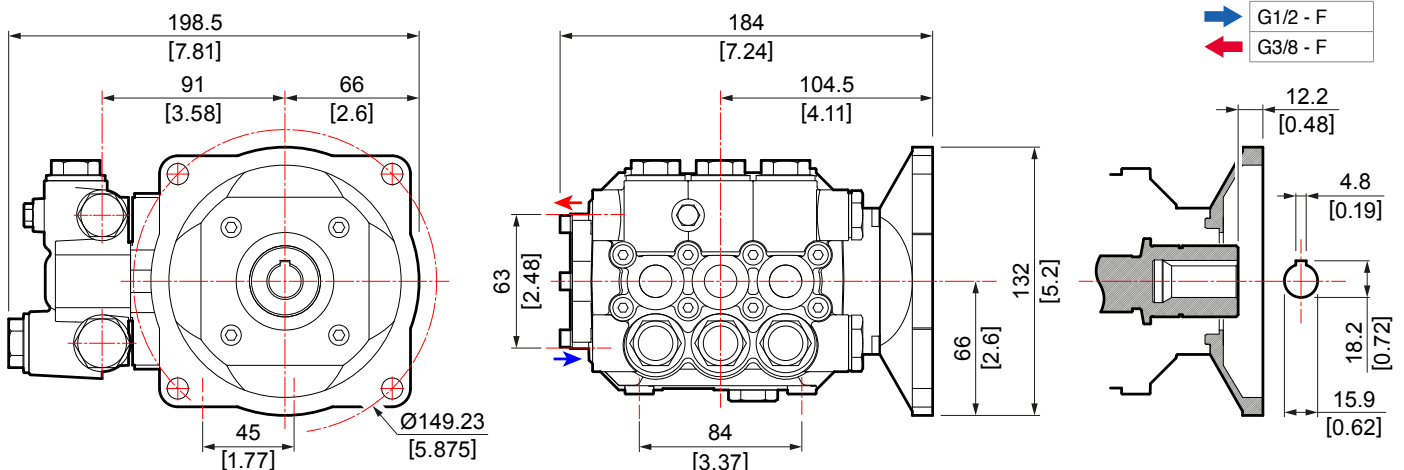



# LW-K



S | Ø24 mm



# LWS-K



# LWR-K



SOLID SHAFT Ø 24 mm › ALBERO MASCHIO Ø 24 mm › EJE MACHO Ø 24 mm

Code Codice Codigo	Model Modello Modelo	Version											
			mm	rpm	l/min	US gpm	bar	psi	Mpa	HP	kW	kg	lb
6300 0351	LW-K 3020	S	24	1450	11,2	3,0	138	2000	13,8	4,0	3,0	7,2	15,9
6300 0850	LW-K 3525	S	24	1450	13,4	3,5	172	2500	17,2	5,5	4,0	7,2	15,9
6301 1250	LWS-K 3525	S	24	1750	13,6	3,6	172	2500	17,2	5,5	4,0	7,2	15,9
6302 0453	LWR-K 3020	S	24	2800	10,8	2,8	138	2000	13,8	4,0	3,0	7,2	15,9
6302 0754	LWR-K 3525	S	24	2800	12,7	3,4	172	2500	17,2	5,5	4,0	7,2	15,9
6302 0854	LWR-K 4022	S	24	2800	14,3	3,8	152	2200	15,2	5,5	4,0	7,2	15,9

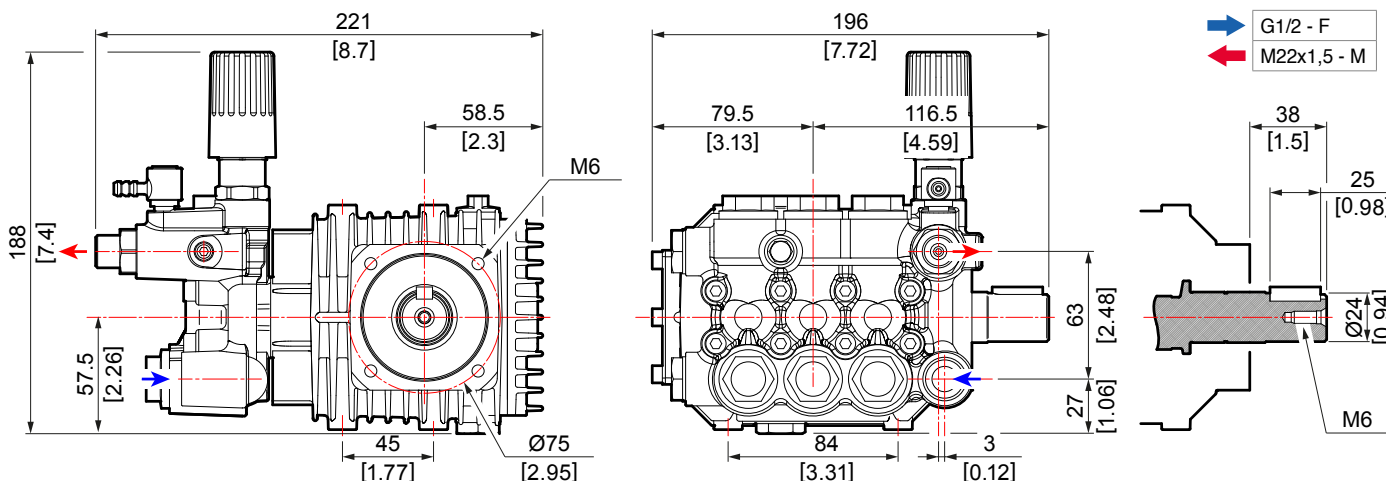



# LWD-K



HOLLOW SHAFT Ø 3/4" › ALBERO FEMMINA Ø 3/4" › EJE HEMBRA Ø 3/4"

Code Codice Codigo	Model Modello Modelo	Version	Ø	RPM	Flow		Pressure			Power		Weight	
			"	rpm	l/min	US gpm	bar	psi	Mpa	HP	kW	kg	lb
6303 1650	LWD-K 2520	G	3/4	3400	9,4	2,5	138	2000	13,8	3,5	2,6	5,8	12,8
6303 0553	LWD-K 3020	G	3/4	3400	11,3	3,0	138	2000	13,8	4,0	3,0	5,8	12,8
6303 0751	LWD-K 3025	G	3/4	3400	11,3	3,0	172	2500	17,2	5,0	3,7	7,2	15,9
6303 0852	LWD-K 3522	G	3/4	3400	13,0	3,4	152	2200	15,2	5,0	3,7	7,2	15,9

## SAE J 609 A

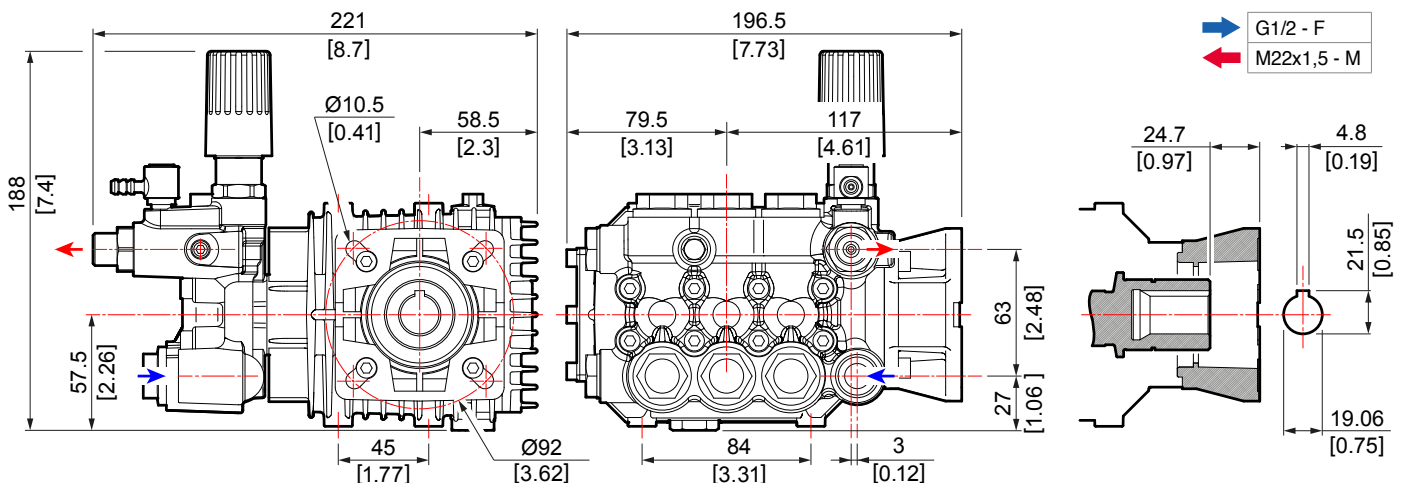



# LW-K



**E** | Ø 24 mm



# LWR-K



HOLLOW SHAFT Ø 24 mm › ALBERO FEMMINA Ø 24 mm › EJE HEMBRA Ø 24 mm

Code Codice Codigo	Model Modello Modelo	Version											
			mm	rpm	l/min	US gpm	bar	psi	Mpa	HP	kW	kg	lb
6300 0552	LW-K 2020	E	24	1450	8,0	2,1	138	2000	13,8	3,0	2,2	5,8	12,8
6302 0156	LWR-K 3016	E	24	2800	11,5	3,1	110	1600	11,0	3,0	2,2	5,5	12,1

## MEC 90 B3-B14

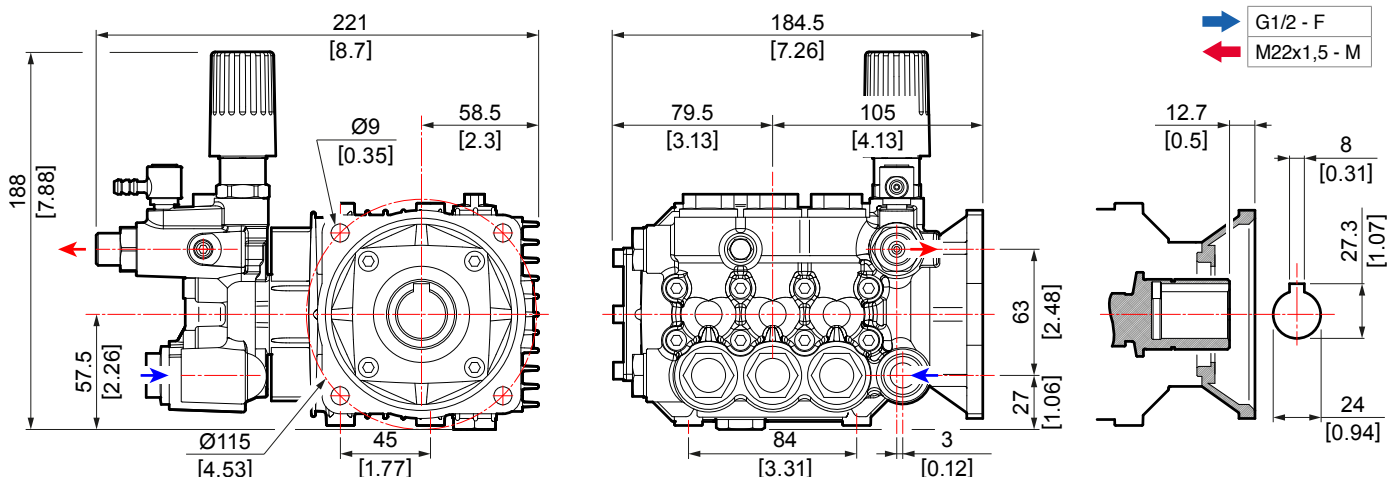



# LWD-K



HOLLOW SHAFT Ø 5/8" › ALBERO FEMMINA Ø 5/8" › EJE HEMBRA Ø 5/8"

Code Codice Codigo	Model Modello Modelo	Version	Ø	RPM	Hand	Pressure				Power			
			"	rpm	l/min	US gpm	bar	psi	Mpa	HP	kW	kg	lb
6303 0153	LWD-K 2020	E	5/8	3400	7,9	2,1	138	2000	13,8	3,0	2,2	5,8	12,8
6303 0554	LWD-K 3020	E	5/8	3400	11,3	3,0	138	2000	13,8	4,0	3,0	5,8	12,8

## NEMA 56 C

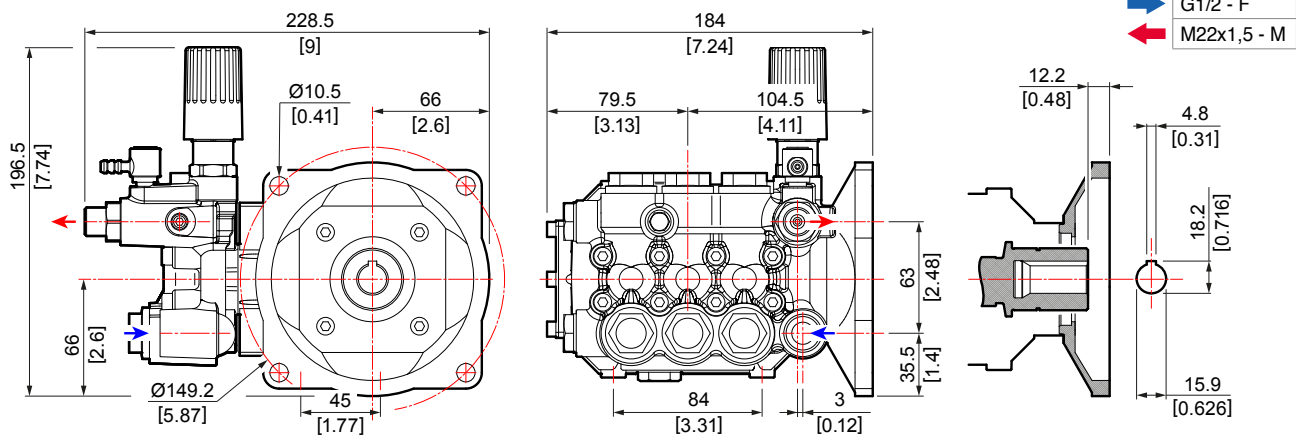



# DWD-K



HOLLOW SHAFT Ø 3/4" › ALBERO FEMMINA Ø 3/4" › EJE HEMBRA Ø 3/4"

Code Codice Codigo	Model Modello Modelo	Version											
			“	rpm	l/min	US gpm	bar	psi	Mpa	HP	kW	kg	lb
6312 0450	DWD-K 2530 G	3/4	3/4	3400	8,8	2,3	207	3000	20,7	4,9	3,7	5,2	11,5

## SAE J 609 A

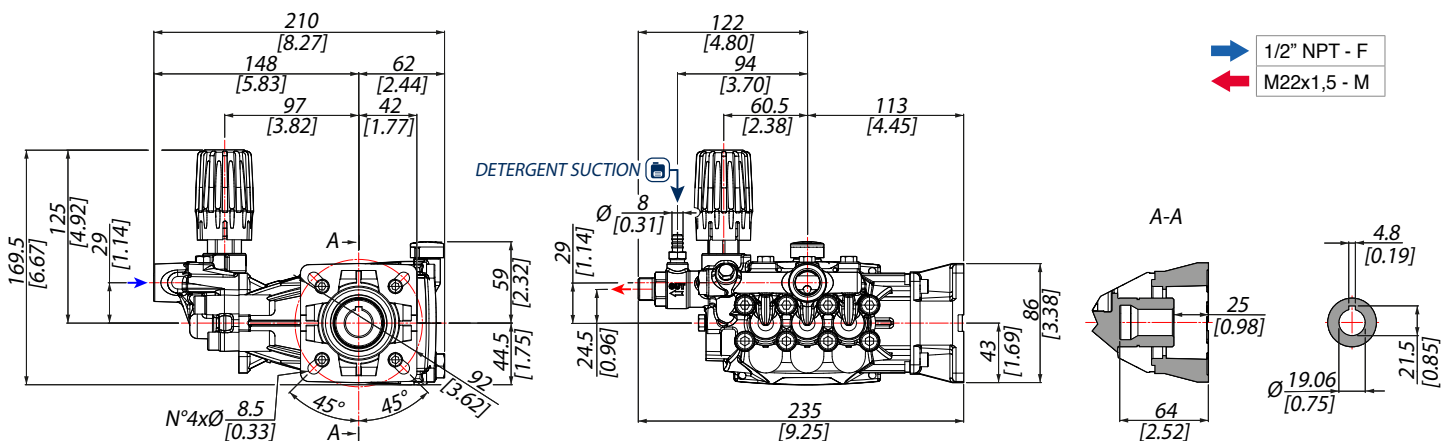



# DWD-K



HOLLOW SHAFT Ø 1" › ALBERO FEMMINA Ø 1" › EJE HEMBRA Ø 1"

Code Codice Codigo	Model Modello Modelo	Version											
			"	rpm	l/min	US gpm	bar	psi	Mpa	HP	kW	kg	lb
6312 0250	DWD-K 3036 G	1	1	3400	11,1	2,9	248	3600	24,8	7,4	5,5	5,5	12,2
6312 0151	DWD-K 3536 G	1	1	3400	12,9	3,4	248	3600	24,8	8,6	6,4	5,5	12,2

## SAE J 609 B

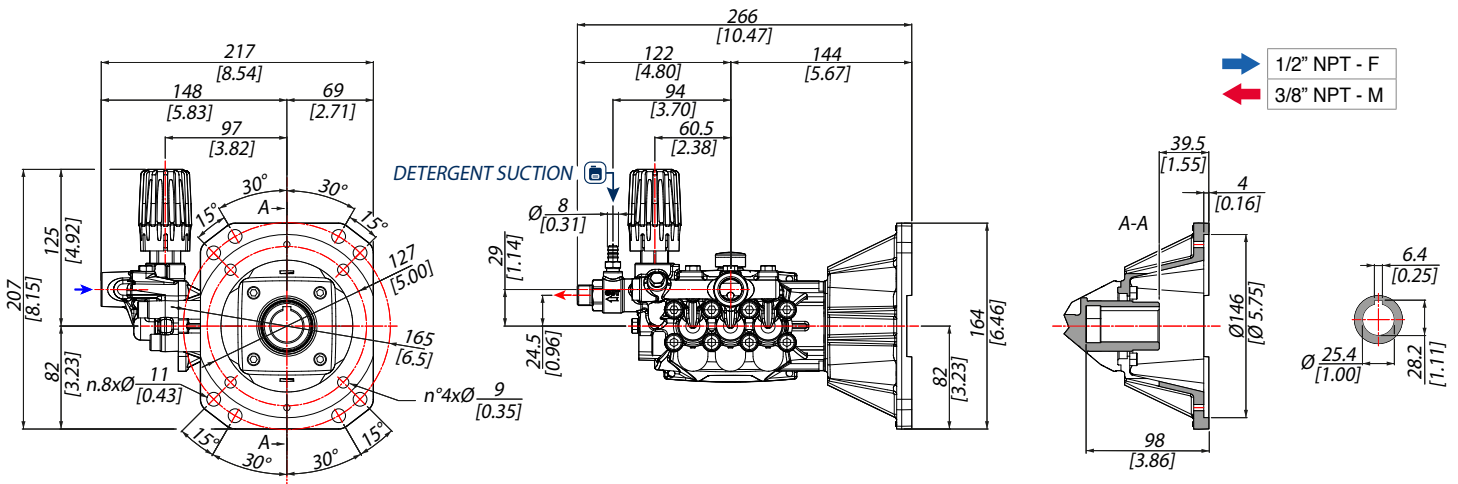



# EWD

S | Ø24 mm



SOLID SHAFT Ø 24 mm › ALBERO MASCHIO Ø 24 mm › EJE MACHO Ø 24 mm

Code Codice Codigo	Model Modello Modelo	Version											
			mm	rpm	l/min	US gpm	bar	psi	Mpa	HP	kW	kg	lb
6311 0102	EWD 4040	S	24	3400	15,0	4,0	276	4000	27,6	11,0	8,2	5,7	12,5

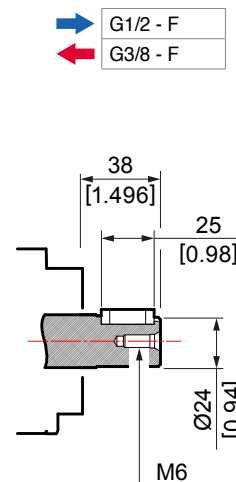
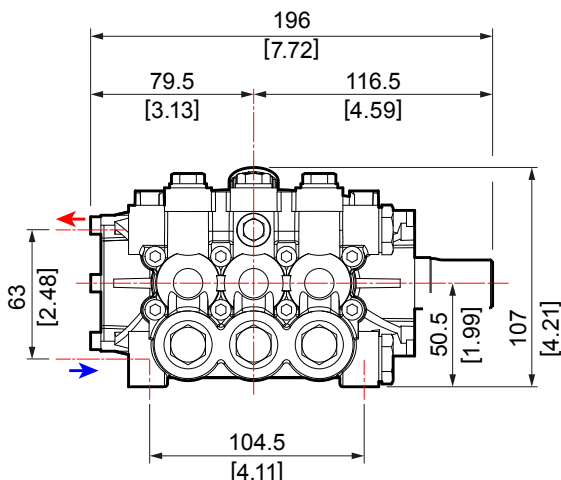
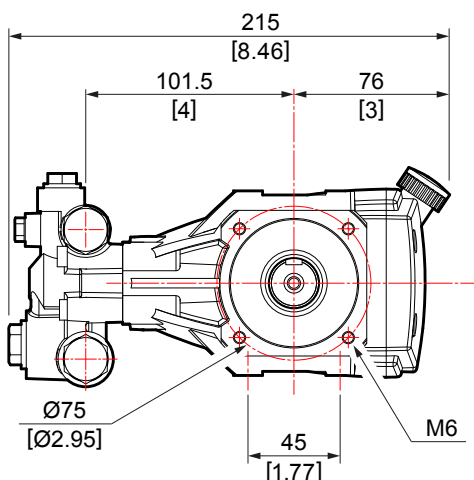





HOLLOW SHAFT Ø 1" › ALBERO FEMMINA Ø 1" › EJE HEMBRA Ø 1"

Code Codice Codigo	Model Modello Modelo	Version	Ø	RPM	Flow		Pressure			Power		Weight	
			"	rpm	l/min	US gpm	bar	psi	Mpa	HP	kW	kg	lb
6311 0200	EWD 3540	G	1	3400	13,1	3,5	276	4000	27,6	9,8	7,3	6,6	14,5
6311 0400	EWD 3545	G	1	3400	13,1	3,5	310	4496	31,0	10,8	8,1	6,6	14,5
6311 0100	EWD 4040	G	1	3400	15,0	4,0	276	4000	27,6	11,0	8,2	6,6	14,5
6311 0500	EWD 4045	G	1	3400	15,0	4,0	310	4496	31,0	12,4	9,3	6,6	14,5

SAE J 609 B

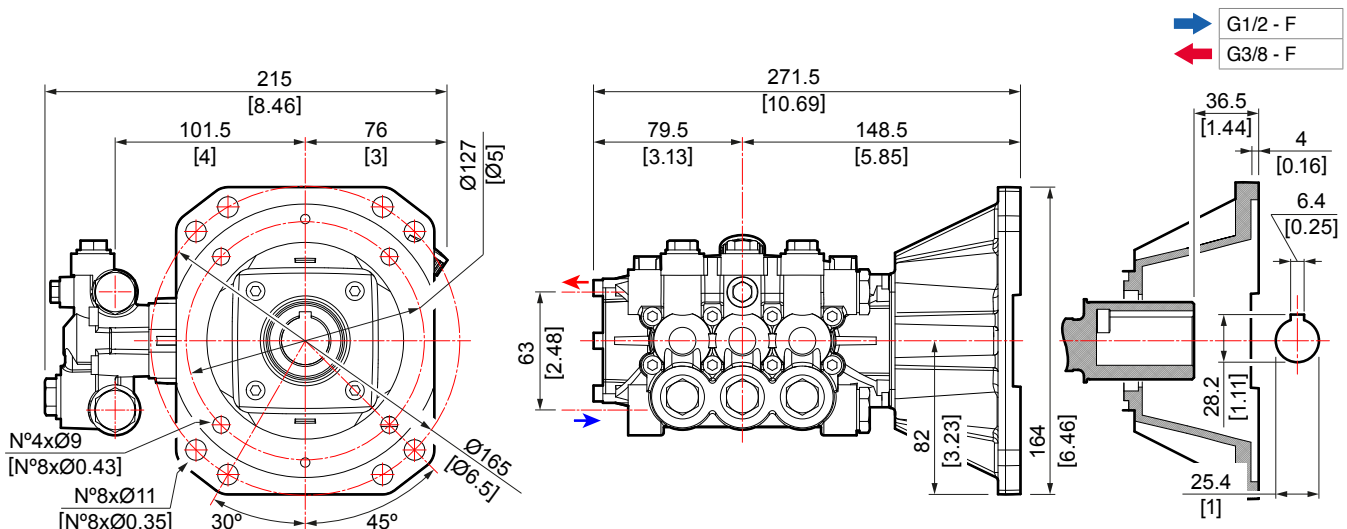



# EWD-K



S | Ø24 mm



**PRESSURE BOOSTER VERSION**



**PATENTED**

To maximize outlet pressure /  
Per massimizzare la pressione  
in uscita / Para maximizar la  
presión de salida

SOLID SHAFT Ø 24 mm › ALBERO MASCHIO Ø 24 mm › EJE MACHO Ø 24 mm

Code Codice Codigo	Model Modello Modelo	Version	Pressure Booster											
				mm	rpm	l/min	US gpm	bar	psi	Mpa	HP	kW	kg	lb
6311 0156	EWD-K 4040	S		24	3400	15,0	4,0	276	4000	27,6	11,0	8,2	5,7	12,5
6311 0158	EWD-K 4040	S	✓	24	3400	15,0	4,0	276	4000	27,6	11,0	8,2	5,7	12,5

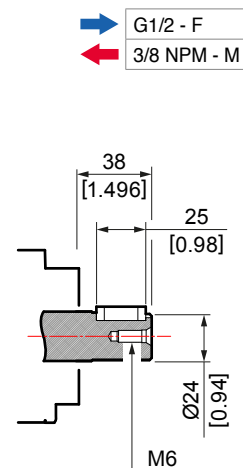
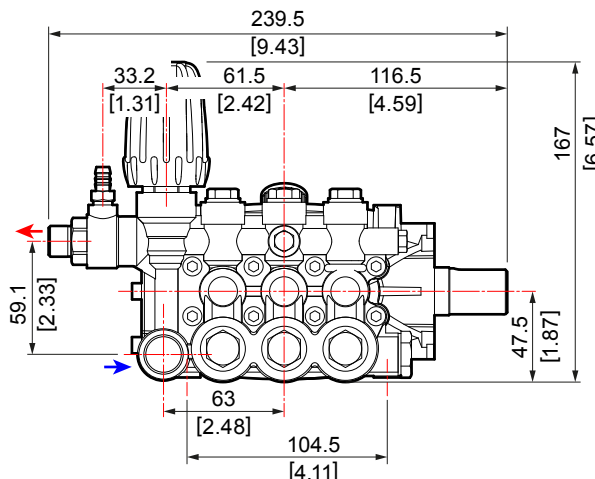
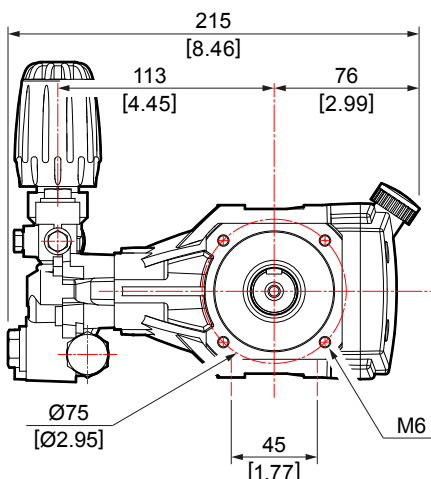



# EWD-K



**PRESSURE BOOSTER VERSION**



**PATENTED**

To maximize outlet pressure /  
Per massimizzare la pressione  
in uscita / Para maximizar la  
presión de salida

HOLLOW SHAFT Ø 1" › ALBERO FEMMINA Ø 1" › EJE HEMBRA Ø 1"

Code Codice Codigo	Model Modello Modelo	Version	Pressure Booster	Ø	RPM	Flow		Pressure			Power		Weight	
				"	rpm	l/min	US gpm	bar	psi	Mpa	HP	kW	kg	lb
6311 0250	EWD-K 3540	G		1	3400	13,1	3,5	276	4000	27,6	9,8	7,3	6,6	14,5
6311 0450	EWD-K 3545	G		1	3400	13,1	3,5	310	4496	31,0	10,8	8,1	6,6	14,5
6311 0150	EWD-K 4040	G		1	3400	15,0	4,0	276	4000	27,6	11,0	8,2	6,6	14,5
6311 0550	EWD-K 4045	G		1	3400	15,0	4,0	310	4496	31,0	12,4	9,3	6,6	14,5
6311 0252	EWD-K 3540	G	✓	1	3400	13,1	3,5	276	4000	27,6	9,8	7,3	6,6	14,5
6311 0157	EWD-K 4040	G	✓	1	3400	15,0	4,0	276	4000	27,6	11,0	8,2	6,6	14,5

## SAE J 609 B

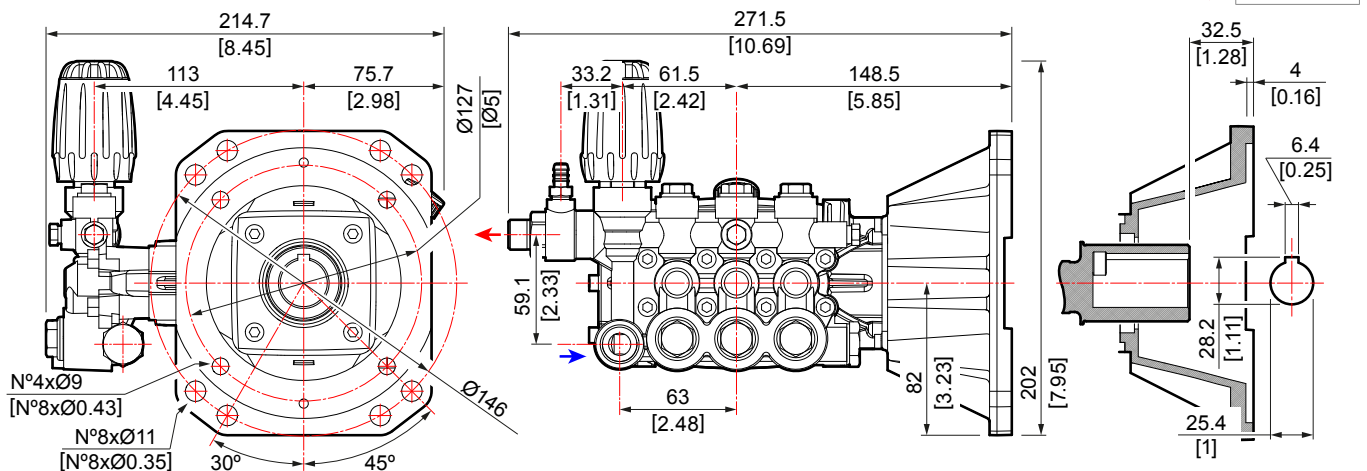



SOLID SHAFT Ø 24 mm › ALBERO MASCHIO Ø 24 mm › EJE MACHO Ø 24 mm

Code Codice Codigo	Model Modello Modelo	Version											
			mm	rpm	l/min	US gpm	bar	psi	Mpa	HP	kW	kg	lb
6307 0800	ZW 3030	S	24	1450	12,3	3,2	207	3000	20,7	6,3	4,7	7,9	17,4
6307 0100	ZW 4022	S	24	1450	15,0	4,0	152	2200	15,2	5,5	4,0	7,5	16,5
6307 0200	ZW 4025	S	24	1450	15,0	4,0	172	2500	17,2	5,8	4,2	7,5	16,5
6307 0500	ZW 4030	S	24	1450	15,0	4,0	207	3000	20,7	7,5	5,5	7,5	16,5

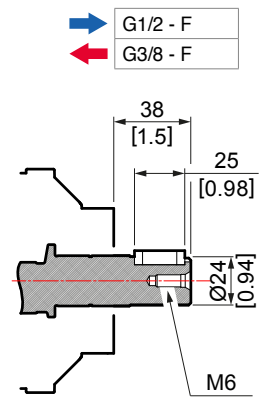
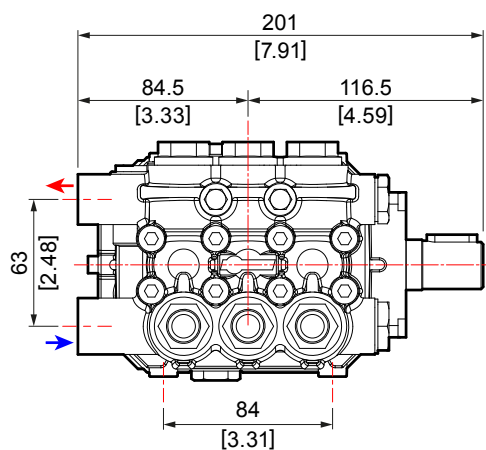
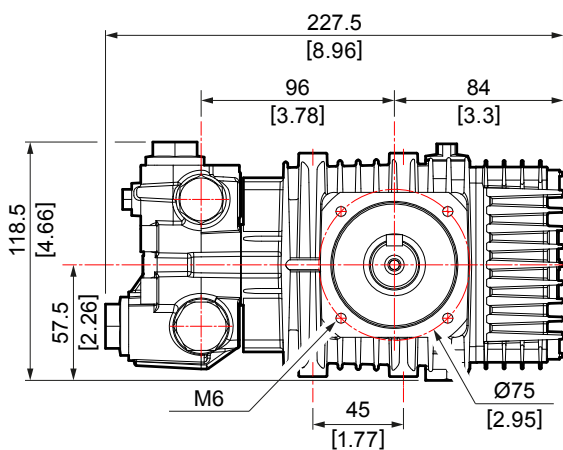

All models are equipped with **EASY-START** device. / Tutti i modelli sono dotati di dispositivo **EASY-START**. / Todos los modelos están equipados con el dispositivo **EASY-START**.



HOLLOW SHAFT Ø 3/4" > ALBERO FEMMINA Ø 3/4" > EJE HEMBRA Ø 3/4"

Code Codice Codigo	Model Modello Modelo	Version											
			"	rpm	l/min	US gpm	bar	psi	Mpa	HP	kW	kg	lb
6305 0700	ZWD 2530	G	3/4	3400	9,4	2,5	207	3000	20,7	5,0	3,7	7,5	16,5
6305 1900	ZWD 2535	G	3/4	3400	9,4	2,5	240	3500	24,0	5,8	4,5	7,9	17,4
6305 1601	ZWD 3035	G	3/4	3400	11,0	3,0	240	3500	27,6	7,0	5,8	7,9	17,4

SAE J 609 A

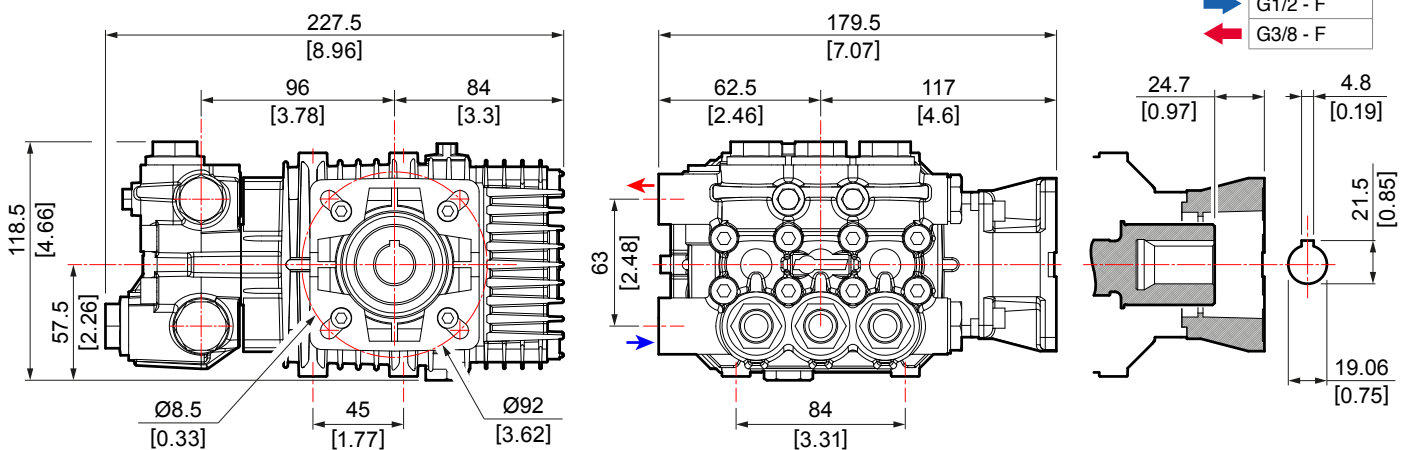



HOLLOW SHAFT Ø 1" › ALBERO FEMMINA Ø 1" › EJE HEMBRA Ø 1"

Code Codice Codigo	Model Modello Modelo	Version											
			"	rpm	l/min	US gpm	bar	psi	Mpa	HP	kW	kg	lb
6305 0100	ZWD 3030	G	1	3400	11,0	3,0	207	3000	20,7	6,0	4,4	7,9	17,4
6305 1600	ZWD 3035	G	1	3400	11,0	3,0	240	3500	24,0	7,0	5,1	7,9	17,4
6305 1100	ZWD 3040	G	1	3400	11,0	3,0	207	3000	20,7	7,9	4,8	7,9	17,4
6305 0400	ZWD 3530	G	1	3400	13,0	3,4	207	3000	20,7	6,5	4,8	7,9	17,4
6305 1700	ZWD 3535	G	1	3400	13,0	3,4	240	3500	24,0	7,6	5,6	7,9	17,4
6305 1000	ZWD 3540	G	1	3400	13,0	3,4	276	4000	27,6	9,5	7,0	7,9	17,4
6305 0600	ZWD 4030	G	1	3400	15,0	4,0	207	3000	20,7	7,5	5,5	7,9	17,4
6305 1800	ZWD 4035	G	1	3400	15,0	4,0	240	3500	24,0	8,7	6,4	7,9	17,4
6305 0900	ZWD 4040	G	1	3400	15,0	4,0	276	4000	27,6	11,0	8,2	7,9	17,4
6305 2100	ZWD 4530	G	1	3400	17,2	4,6	207	3000	20,7	9,8	7,2	7,9	17,4
6305 2400	ZWD 5030	G	1	3400	19,2	5,1	207	3000	20,7	10,8	8,0	7,9	17,4
6305 2500	ZWD 5530	G	1	3400	20,8	5,5	207	3000	20,7	11,6	8,7	7,9	17,4

SAE J 609 B

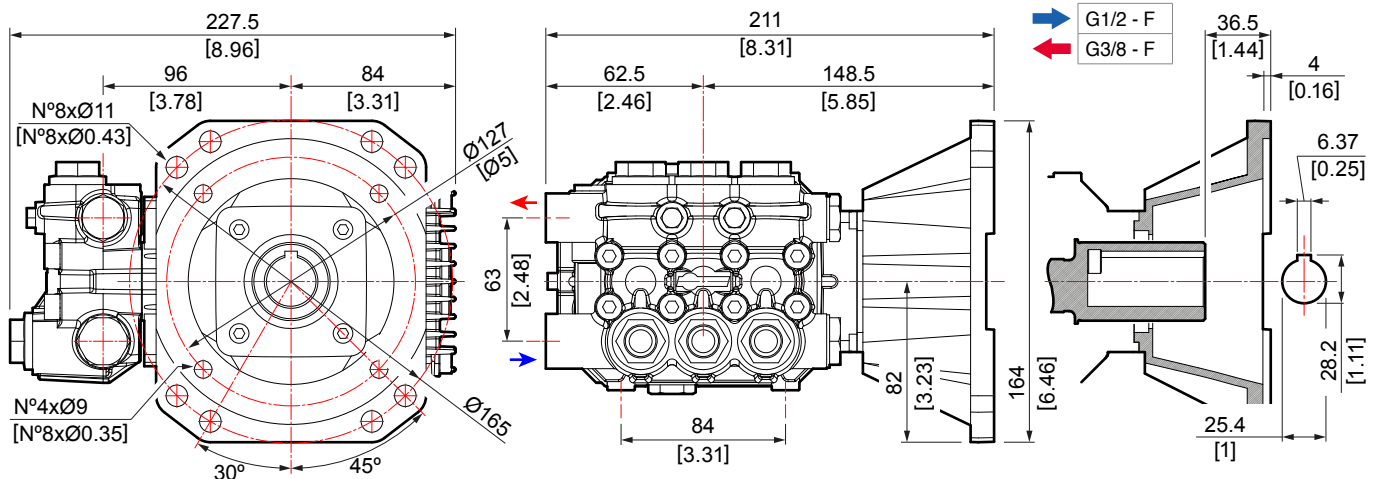

**ZW**

**E** | Ø 28 mm

**ZWR**



HOLLOW SHAFT Ø 28 mm > ALBERO FEMMINA Ø 28 mm > EJE HEMBRA Ø 28 mm

Code Codice Codigo	Model Modello Modelo	Version											
			mm	rpm	l/min	US gpm	bar	psi	Mpa	HP	kW	kg	lb
6307 0803	ZW 3030	E	28	1450	11,5	3,0	207	3000	20,7	5,9	4,3	8,5	18,7
6307 1200	ZW 4018	E	28	1450	14,7	3,9	125	1800	12,5	4,5	3,3	8,5	18,7
6307 0504	ZW 4030	E	28	1450	14,7	3,9	207	3000	20,7	7,5	5,5	8,5	18,7
6306 0200	ZWR 3030	E	28	2800	11,8	3,1	207	3000	20,7	6,1	4,5	8,5	18,7
6306 0101	ZWR 4030	E	28	2800	15,4	4,1	207	3000	20,7	7,9	5,8	8,5	18,7

**MEC 110-112**

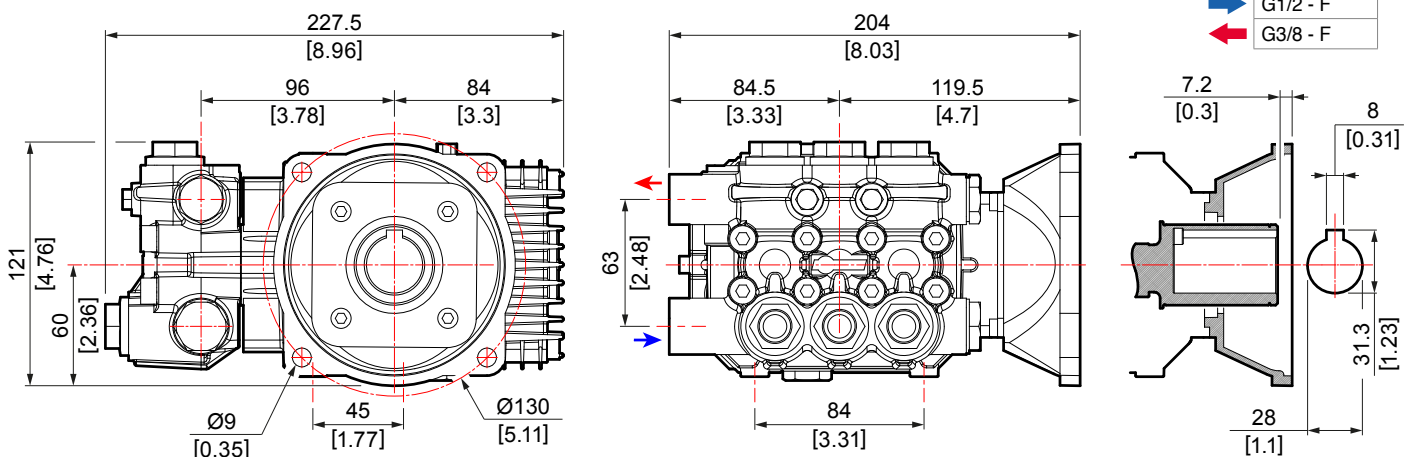

1450 R.P.M. models are equipped with **EASY-START** device. / I modelli a 1450 R.P.M. sono dotati di dispositivo **EASY-START**. / Los modelos a 1450 R.P.M. están equipados con el dispositivo **EASY-START**.



# ZW-K



S | Ø24 mm



SOLID SHAFT Ø 24 mm › ALBERO MASCHIO Ø 24 mm › EJE MACHO Ø 24 mm

Code Codice Codigo	Model Modello Modelo	Version											
			mm	rpm	l/min	US gpm	bar	psi	Mpa	HP	kW	kg	lb
6307 0350	ZW-K 3525	S	24	1450	13,4	3,5	172	2500	17,2	5,5	4,0	7,2	15,9
6307 0150	ZW-K 4022	S	24	1450	15,0	4,0	152	2200	15,2	5,5	4,0	7,2	15,9
6307 0154	ZW-K 4025	S	24	1450	15,0	4,0	172	2500	17,2	6,5	4,8	7,2	15,9
6307 0550	ZW-K 4030	S	24	1450	15,0	4,0	207	3000	20,7	7,5	5,5	7,2	15,9

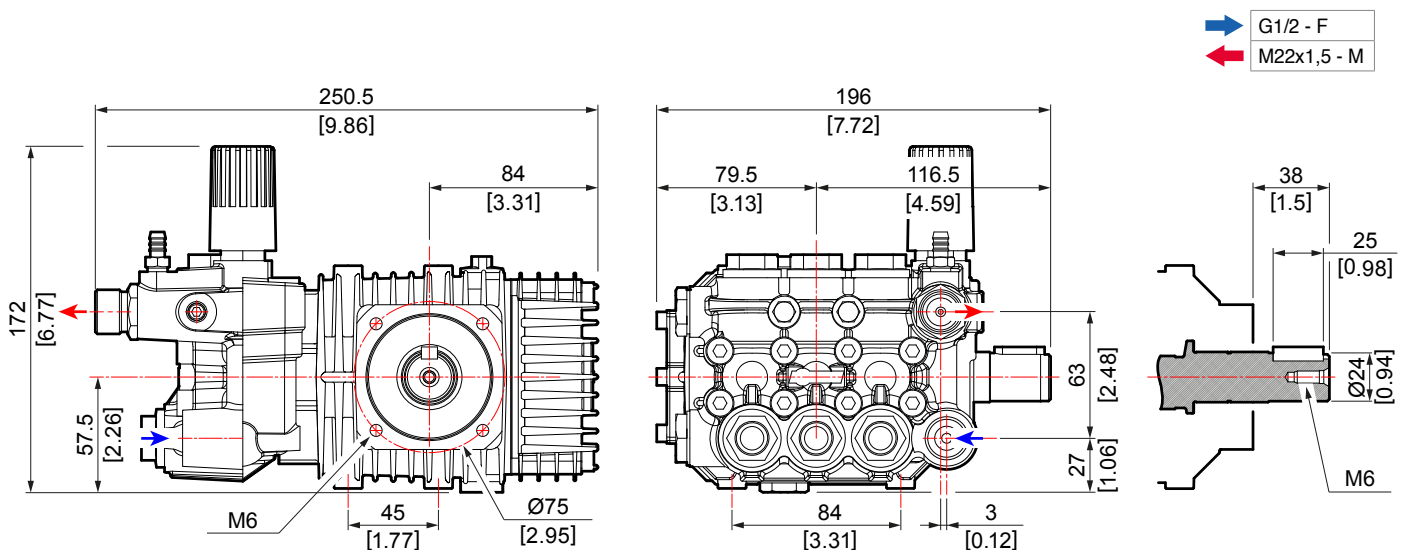

All models are equipped with **EASY-START** device. / Tutti i modelli sono dotati di dispositivo **EASY-START**. / Todos los modelos están equipados con el dispositivo **EASY-START**.





# ZWD-K



HOLLOW SHAFT Ø 1" › ALBERO FEMMINA Ø 1" › EJE HEMBRA Ø 1"

Code Codice Codigo	Model Modello Modelo	Version	Ø	RPM	Flow		Pressure			Power		Weight	
			"	rpm	l/min	US gpm	bar	psi	Mpa	HP	kW	kg	lb
6305 0151	ZWD-K 3030	G	1	3400	11,0	3,0	207	3000	20,7	6,0	4,4	7,9	17,4
6305 1650	ZWD-K 3035	G	1	3400	11,0	3,0	240	3500	24,0	7,0	5,1	7,9	17,4
6305 0450	ZWD-K 3530	G	1	3400	13,0	3,4	207	3000	20,7	6,5	4,8	7,9	17,4
6305 1750	ZWD-K 3535	G	1	3400	13,0	3,4	240	3500	24,0	7,6	5,6	7,9	17,4
6305 1052	ZWD-K 3540	G	1	3400	13,0	3,5	276	4000	27,6	9,5	7,0	7,9	17,4
6305 0652	ZWD-K 4030	G	1	3400	15,0	4,0	207	3000	20,7	7,5	5,5	7,9	17,4
6305 1850	ZWD-K 4035	G	1	3400	15,0	4,0	240	3500	24,0	8,7	6,4	7,9	17,4
6305 1504	ZWD-K 4040	G	1	3400	15,0	4,0	276	4000	27,6	11,0	8,2	7,9	17,4

## SAE J 609 B

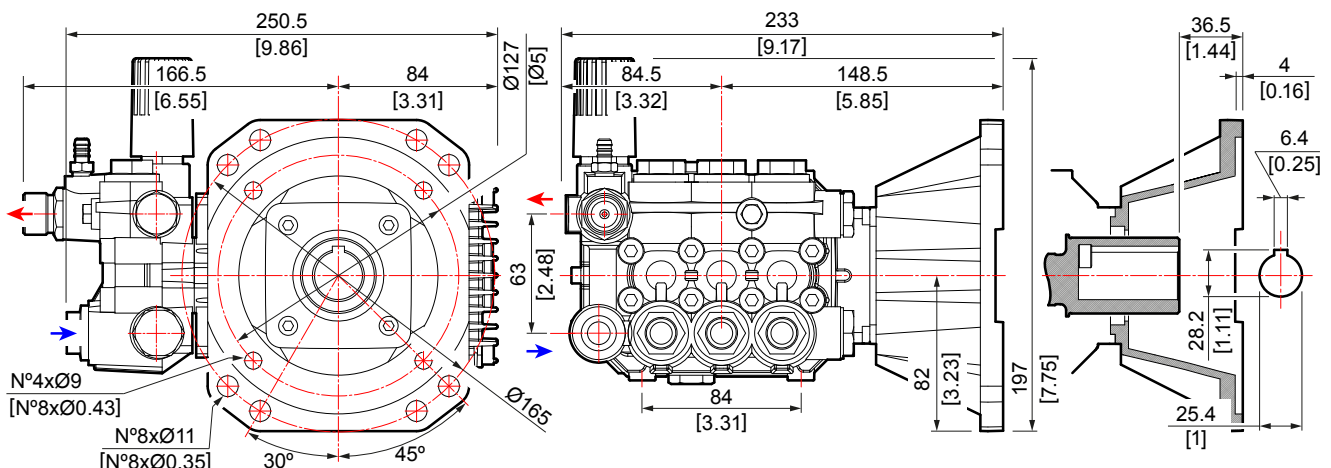
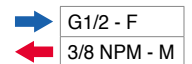

The model ZWD-K 4040G is equipped with **EASY-START** device. / Il modello ZWD-K 4040G è dotato di dispositivo **EASY-START**. / El modelo ZWD-K 4040G se ha equipado con el dispositivo **EASY-START**.



# FW2

S | Ø24 mm



# FWS2



ON REQUEST › SU RICHIESTA › BAJO PEDIDO



**NICKEL PLATED HEAD**  
TESTATA NICHELATA  
CABEZA NIQUELADA

SOLID SHAFT Ø 24 mm › ALBERO MASCHIO Ø 24 mm › EJE MACHO Ø 24 mm

Code Codice Codigo	Model Modello Modelo	Version											
			mm	rpm	l/min	US gpm	bar	psi	Mpa	HP	kW	kg	lb
6410 1500	FW2 2020	S	24	1450	7,8	2,1	138	2000	13,8	2,7	2,0	8,8	19,4
6410 0200	FW2 3530	S	24	1450	13,0	3,4	207	3000	20,7	7,0	5,1	8,8	19,4
6410 0600	FW2 4022	S	24	1450	15,4	4,1	152	2200	15,2	5,5	4,0	8,8	19,4
6410 0100	FW2 4030	S	24	1450	15,2	4,0	207	3000	20,7	7,5	5,5	8,8	19,4
6410 0700	FW2 4040	S	24	1450	15,0	4,0	278	4000	27,8	11,0	8,2	8,8	19,4
6410 0800	FW2 4540	S	24	1450	16,5	4,4	276	4000	27,6	12,2	9,0	8,8	19,4
6410 0300	FW2 5030	S	24	1450	18,8	5,0	207	3000	20,7	10,0	7,5	8,8	19,4
6410 0400	FW2 5522	S	24	1450	21,0	5,6	152	2200	15,2	7,5	5,5	8,8	19,4
6410 0500	FW2 5530	S	24	1450	21,0	5,6	207	3000	20,7	10,5	7,7	8,8	19,4
6411 0100	FWS2 3530	S	24	1750	13,7	3,6	207	3000	20,7	7,0	5,1	8,8	19,4
6411 0200	FWS2 4030	S	24	1750	15,7	4,2	207	3000	20,7	7,5	5,5	8,8	19,4
6411 1100	FWS2 4040	S	24	1750	15,7	4,2	276	4000	27,6	11,0	8,2	8,8	19,4
6411 0300	FWS2 4530	S	24	1750	17,5	4,6	207	3000	20,7	10,0	7,5	8,8	19,4
6411 1200	FWS2 5040	S	24	1750	20,0	5,3	276	4000	27,6	14,0	10,5	8,8	19,4
6411 0600	FWS2 5525	S	24	1750	21,6	5,7	172	2500	17,2	10,0	7,5	8,8	19,4
6411 0700	FWS2 5530	S	24	1750	21,0	5,5	207	3000	20,7	10,5	7,7	8,8	19,4
6411 0800	FWS2 6020	S	24	1750	22,4	5,9	138	2000	13,8	7,5	5,5	8,8	19,4
6411 1400	FWS2 6030	S	24	1750	22,4	5,9	207	3000	20,7	11,9	8,9	8,8	19,4

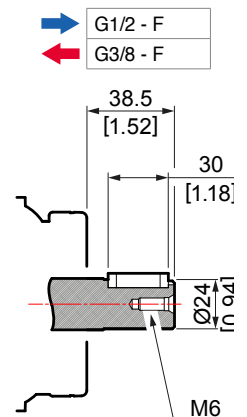
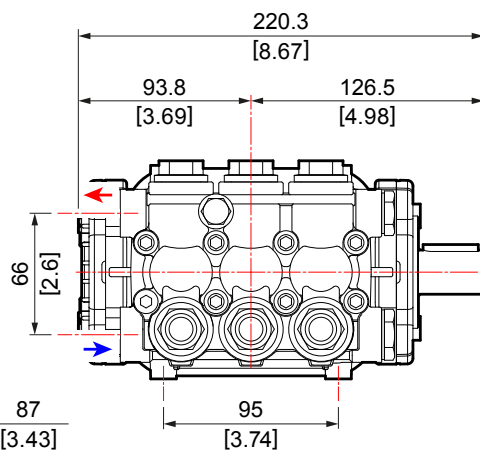
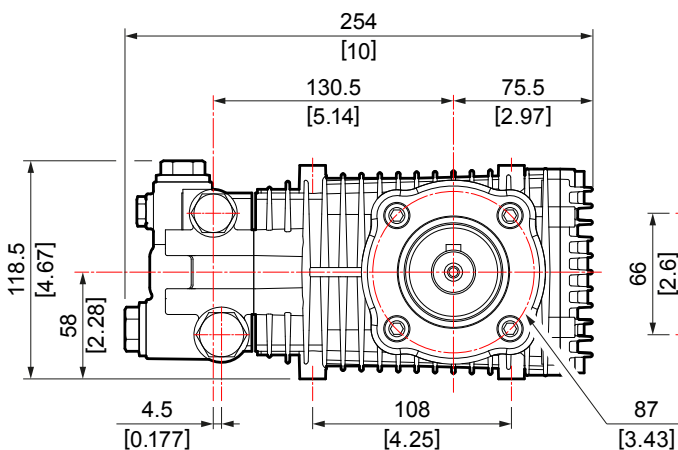



# FWS2



ON REQUEST › SU RICHIESTA › BAJO PEDIDO



HOLLOW SHAFT Ø 25 mm › ALBERO FEMMINA Ø 25 mm › EJE HEMBRA Ø 25 mm

Code Codice Codigo	Model Modello Modelo	Version											
			mm	rpm	l/min	US gpm	bar	psi	Mpa	HP	kW	kg	lb
● 6411 0103	FWS2 3530	G	25	1750	13,7	3,6	207	3000	20,7	7,0	5,1	8,9	19,6
▲ 6411 0104	FWS2 3530	G	25	1750	13,7	3,6	207	3000	20,7	7,0	5,1	8,9	19,6
▲ 6411 0206	FWS2 4030	G	25	1750	15,7	4,2	207	3000	20,7	7,5	5,5	8,9	19,6
● 6411 0207	FWS2 4030	G	25	1750	15,7	4,2	207	3000	20,7	7,5	5,5	8,8	19,4
▲ 6411 0401	FWS2 5030	G	25	1750	18,8	5,0	207	3000	20,7	10,0	7,5	8,9	19,6
● 6411 0402	FWS2 5030	G	25	1750	18,8	5,0	207	3000	20,7	10,0	7,5	8,9	19,6

P.T.O. on left hand side except 6411 0206 - Presa di forza sul lato sinistro eccetto 6411 0206 - Toma de fuerza en el lado izquierdo excepto 6411 0206

## SPECIAL FLANGE (MITSUBISHI)

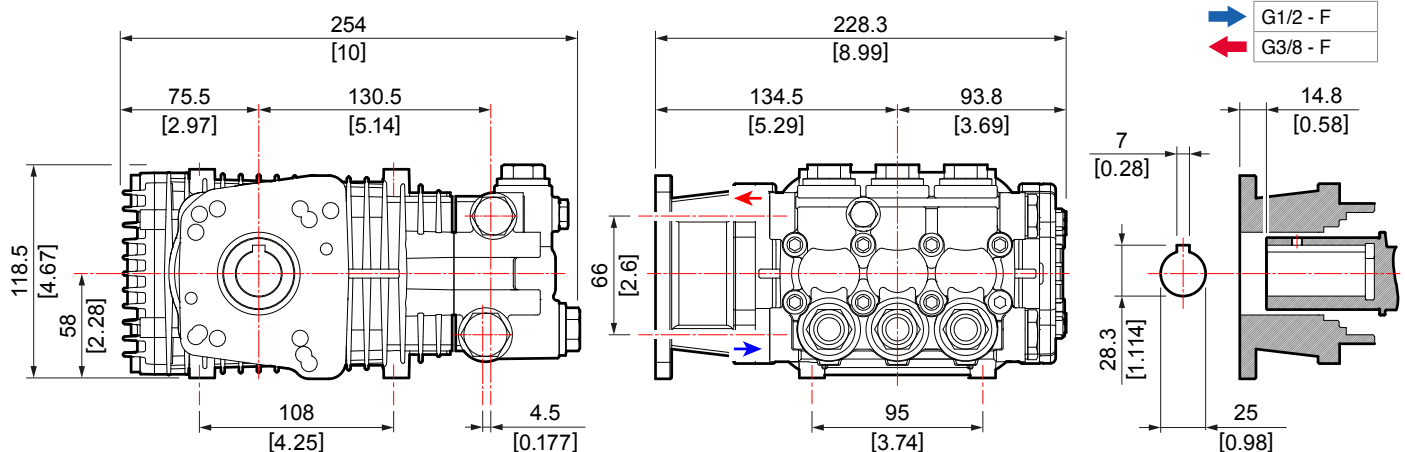

▲ For Honda motor / Per motore Honda / Para motor Honda.  
 ● For Mitsubishi-Robin motor / Per motore Mitsubishi-Robin / Para motor Mitsubishi-Robin.

Contact us for other special flange drawings. / I disegni delle altre flange speciali sono disponibili su richiesta. / Contactar para los dibujos de las otras bridas especiales.



# FWD2



ON REQUEST › SU RICHIESTA › BAJO PEDIDO



**NICKEL PLATED HEAD**  
TESTATA NICHELATA  
CABEZA NIQUELADA

HOLLOW SHAFT Ø 1" › ALBERO FEMMINA Ø 1" › EJE HEMBRA Ø 1"

Code Codice Codigo	Model Modello Modelo	Version	Ø	RPM	Hand	Pressure	Power	Weight					
			"	rpm	l/min	US gpm	bar	psi	Mpa	HP	kW	kg	lb
6412 0101	FWD2 4530 G	1	1	3400	16,5	4,3	207	3000	20,7	9,5	7,1	9,0	19,8
6412 0300	FWD2 4540 G	1	1	3400	16,5	4,3	276	4000	27,6	12,6	9,5	9,0	19,8
6412 0201	FWD2 5030 G	1	1	3400	19,2	5,1	207	3000	20,7	11,0	8,3	9,0	19,8
6412 0400	FWD2 5040 G	1	1	3400	19,2	5,1	276	4000	27,6	14,7	11,0	9,0	19,8
6412 0500	FWD2 5540 G	1	1	3400	20,9	5,5	276	4000	27,6	15,6	11,6	9,0	19,8

## SAE J 609 B

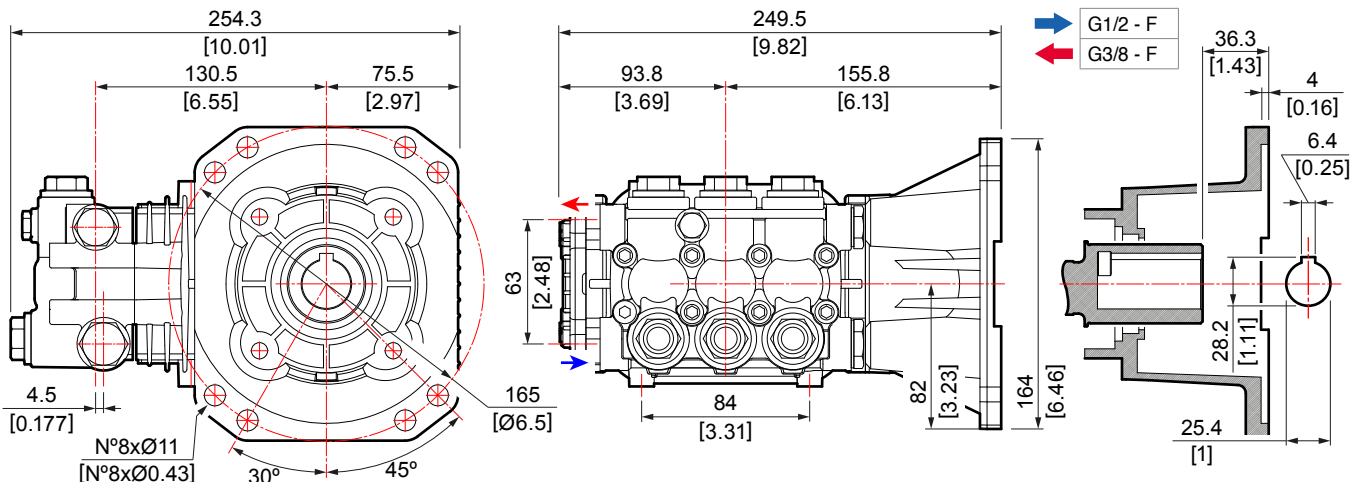



ON REQUEST › SU RICHIESTA › BAJO PEDIDO



**NICKEL PLATED HEAD**  
TESTATA NICHELATA  
CABEZA NIQUELADA

HOLLOW SHAFT Ø 28 mm › ALBERO FEMMINA Ø 28 mm › EJE HEMBRA Ø 28 mm

Code Codice Codigo	Model Modello Modelo	Version											
			mm	rpm	l/min	US gpm	bar	psi	Mpa	HP	kW	kg	lb
6410 1100	FW2 4530	E	28	1450	16,8	4,4	207	3000	20,7	8,7	6,4	9,3	20,5
6410 0507	FW2 5530	E	28	1450	20,7	5,5	207	3000	20,7	10,8	7,9	9,3	20,5

**MEC 110-112**

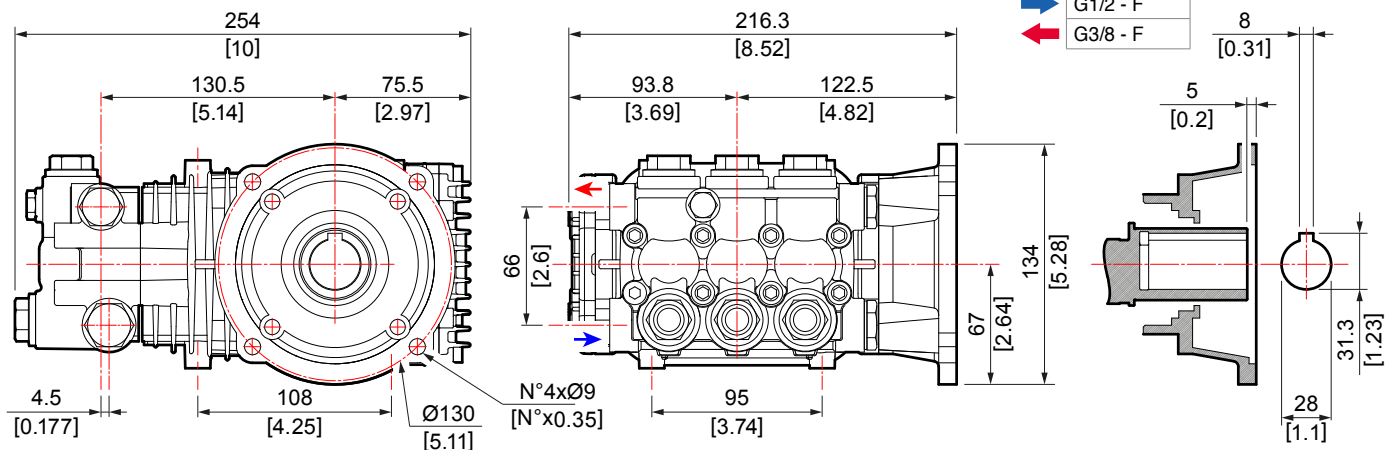



# FWS2

**E** | Ø1"1/8



# FWD2



ON REQUEST › SU RICHIESTA › BAJO PEDIDO



HOLLOW SHAFT Ø1"1/8 › ALBERO FEMMINA Ø1"1/8 › EJE HEMBRA Ø1"1/8

Code Codice Codigo	Model Modello Modelo	Version	Ø	RPM	Hand	Pressure	Pressure			Power	Weight		
			"	rpm	l/min	US gpm	bar	psi	Mpa	HP	kW	kg	lb
6411 0900	FWS2 3030	E	1 1/8	1750	10,9	2,9	207	3000	20,7	5,8	4,2	8,9	19,6
6411 1000	FWS2 3522	E	1 1/8	1750	13,6	3,6	152	2200	15,2	5,2	3,8	8,9	19,6
6411 0101	FWS2 3530	E	1 1/8	1750	13,7	3,6	207	3000	20,7	7,0	5,1	8,9	19,6
6411 0201	FWS2 4030	E	1 1/8	1750	15,7	4,2	207	3000	20,7	7,5	5,5	8,9	19,6
6411 0301	FWS2 4530	E	1 1/8	1750	17,5	4,6	207	3000	20,7	10,0	7,5	8,9	19,6
6411 0400	FWS2 5030	E	1 1/8	1750	18,8	5,0	207	3000	20,7	10,0	7,5	8,9	19,6
6411 0701	FWS2 5530	E	1 1/8	1750	21	5,5	207	3000	20,7	10,5	7,7	8,9	19,6
6412 0100	FWD2 4530	E	1 1/8	3400	16,5	4,3	207	3000	20,7	9,5	7,1	9,0	19,8
6412 0301	FWD2 4540	E	1 1/8	3400	16,5	4,3	276	4000	27,6	12,6	9,5	9,0	19,8
6412 0202	FWD2 5030	E	1 1/8	3400	19,2	5,1	207	3000	20,7	11,0	8,3	9,0	19,8
6412 0401	FWD2 5040	E	1 1/8	3400	19,2	5,1	276	4000	27,6	14,7	11,0	9,0	19,8

## NEMA 182-184 TC

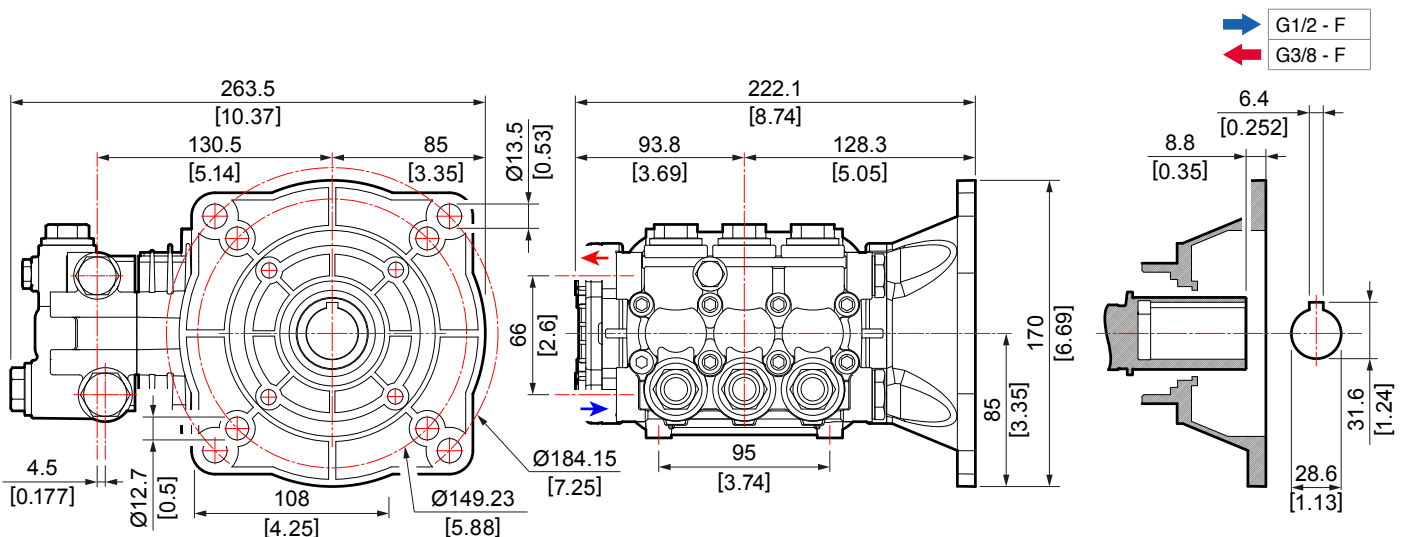



# RWN

S | Ø24 mm

**PREMIUM**



ON REQUEST › SU RICHIESTA › BAJO PEDIDO



**NICKEL PLATED HEAD**  
TESTATA NICHELATA  
CABEZA NIQUELADA

SOLID SHAFT Ø 24 mm › ALBERO MASCHIO Ø 24 mm › EJE MACHO Ø 24 mm

Code Codice Codigo	Model Modello Modelo	Version											
			mm	rpm	l/min	US gpm	bar	psi	Mpa	HP	kW	kg	lb
6519 0200	RWN 4030 S		24	1000	14,3	3,8	207	3000	20,7	7,5	5,6	11,2	24,6
6519 0300	RWN 4530 S		24	1000	16,1	4,3	207	3000	20,7	8,4	6,2	11,2	24,6

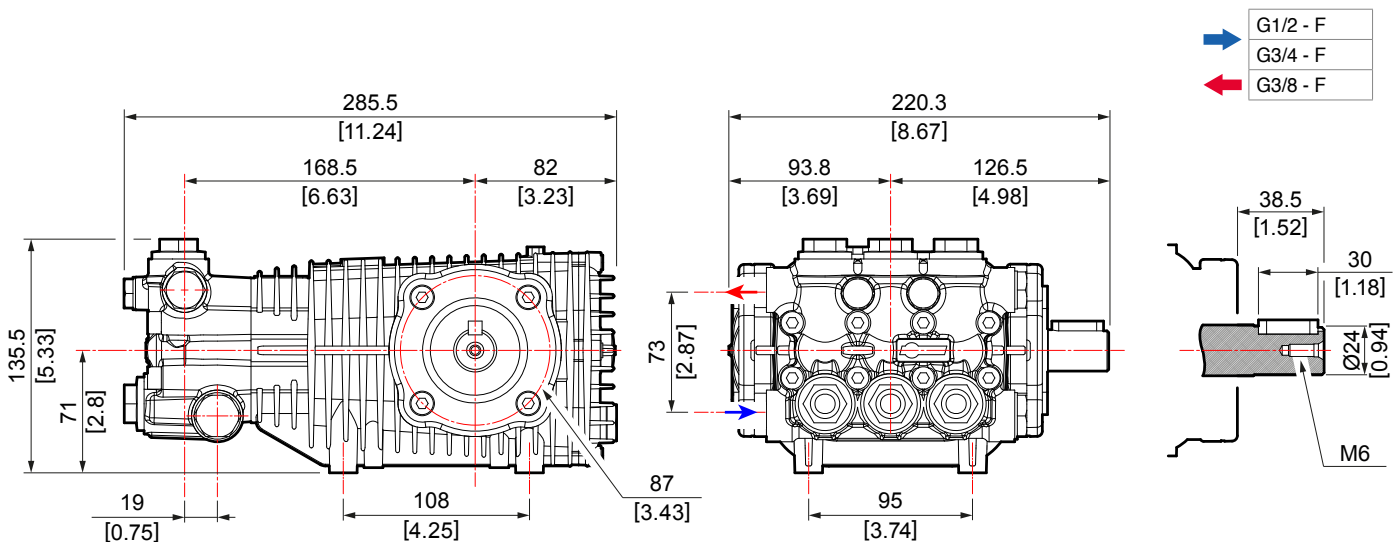



**PREMIUM**



ON REQUEST › SU RICHIESTA › BAJO PEDIDO



SOLID SHAFT Ø 24 mm › ALBERO MASCHIO Ø 24 mm › EJE MACHO Ø 24 mm

Code Codice Codigo	Model Modello Modelo	Version											
			mm	rpm	l/min	US gpm	bar	psi	Mpa	HP	kW	kg	lb
6517 0201	RW 3040	S	24	1450	11,0	3,0	276	4000	27,6	7,9	4,8	11,2	24,6
6517 2200	RW 3045	S	24	1450	11,2	3,0	310	4500	31,0	8,8	6,6	11,5	25,3
6517 0300	RW 3530	S	24	1450	13,0	3,4	207	3000	20,7	6,7	5,0	11,2	24,6
6517 1001	RW 3540	S	24	1450	12,6	3,3	276	4000	27,6	8,7	6,4	11,2	24,6
6517 2300	RW 3545	S	24	1450	12,4	3,3	310	4500	31,0	9,8	7,3	11,5	25,3
6517 0400	RW 4022	S	24	1450	15,6	4,1	152	2200	15,2	5,9	4,4	11,2	24,6
6517 0100	RW 4030	S	24	1450	15,6	4,1	207	3000	20,7	8,1	5,9	11,2	24,6
6517 1400	RW 4040	S	24	1450	15,6	4,0	276	4000	27,6	10,6	7,8	11,2	24,6
6517 2400	RW 4045	S	24	1450	15,2	4,0	310	4500	31,0	11,9	8,9	11,5	25,3
6517 1101	RW 4540	S	24	1450	16,8	4,4	276	4000	27,6	11,6	8,6	11,2	24,6
6517 2500	RW 4545	S	24	1450	16,8	4,4	310	4500	31,0	13,1	9,8	11,5	25,3
6517 0500	RW 5022	S	24	1450	18,8	5,0	152	2200	15,2	7,2	5,3	11,2	24,6
6517 0600	RW 5030	S	24	1450	18,8	5,0	207	3000	20,7	9,8	7,2	11,2	24,6
6517 1201	RW 5040	S	24	1450	19,9	5,0	276	4000	27,6	13,1	9,6	11,2	24,6
6517 2600	RW 5045	S	24	1450	18,9	5,0	310	4500	31,0	14,7	11,0	11,5	25,3
6517 0800	RW 5530	S	24	1450	20,8	5,1	207	3000	20,7	10,8	7,9	11,2	24,6
6517 1300	RW 5535	S	24	1450	20,1	5,3	241	3500	24,1	12,6	9,3	11,2	24,6
6517 0900	RW 6030	S	24	1450	23,4	6,2	207	3000	20,7	12,1	8,9	11,2	24,6
6517 1700	RW 6522	S	24	1450	24,9	6,6	152	2200	15,2	9,6	7,1	11,2	24,6
6517 1800	RW 7522	S	24	1450	27,7	7,3	152	2200	15,2	10,8	8,0	11,2	24,6
6517 1900	RW 8018	S	24	1450	29,7	7,9	124	1800	12,4	11,9	8,9	11,2	24,6
6517 2000	RW 8518	S	24	1450	32,8	8,7	124	1800	12,4	11,9	8,9	11,2	24,6
6517 2100	RW 9518	S	24	1450	36,9	9,8	124	1800	12,4	11,9	8,9	11,2	24,6

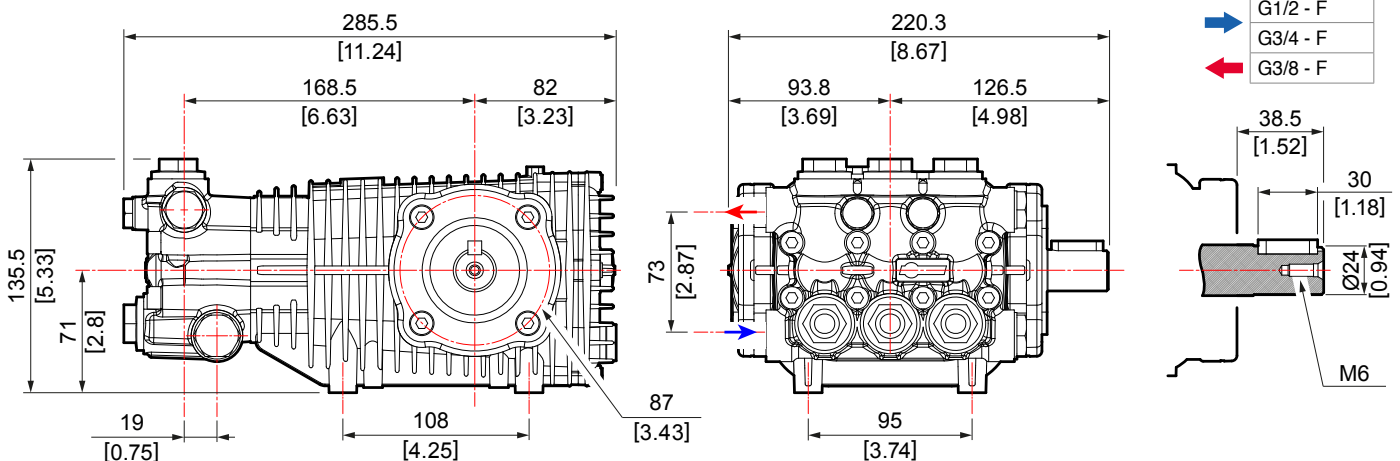





PREMIUM



ON REQUEST › SU RICHIESTA › BAJO PEDIDO



**NICKEL PLATED HEAD**  
TESTATA NICHELATA  
CABEZA NIQUELADA

SOLID SHAFT Ø 24 mm › ALBERO MASCHIO Ø 24 mm › EJE MACHO Ø 24 mm

Code Codice Codigo	Model Modello Modelo	Version											
			mm	rpm	l/min	US gpm	bar	psi	Mpa	HP	kW	kg	lb
6518 1101	RWS 3540	S	24	1750	13,6	3,6	276	4000	27,6	9,5	7,0	11,2	24,6
6518 0300	RWS 4022	S	24	1750	15,5	4,1	152	2200	15,2	6,0	4,4	11,2	24,6
6518 0400	RWS 4030	S	24	1750	15,0	4,0	207	3000	20,7	8,1	6,0	11,2	24,6
6518 1201	RWS 4040	S	24	1750	15,1	4,0	276	4000	27,6	10,5	7,8	11,2	24,6
6518 2500	RWS 4045	S	24	1750	15,1	4,0	310	4500	31,0	11,9	8,8	11,5	25,3
6518 1301	RWS 4540	S	24	1750	18,2	4,8	276	4000	27,6	12,7	9,4	11,2	24,6
6518 2600	RWS 4545	S	24	1750	18,0	4,8	310	4500	31,0	14,3	10,7	11,5	25,3
6518 0600	RWS 5030	S	24	1750	18,6	4,9	207	3000	20,7	9,8	7,2	11,2	24,6
6518 1401	RWS 5040	S	24	1750	20,1	5,3	276	4000	27,6	14,1	10,3	11,2	24,6
6518 2700	RWS 5045	S	24	1750	20,3	5,4	310	4500	31,0	15,8	11,8	11,5	25,3
6518 0700	RWS 5530	S	24	1750	21,4	5,7	207	3000	20,7	11,2	8,3	11,2	24,6
6518 1500	RWS 5535	S	24	1750	21,4	5,7	241	3500	24,1	13,1	9,6	11,2	24,6
6518 0801	RWS 6040	S	24	1750	22,6	6,0	276	4000	27,6	15,8	11,6	11,2	24,6
6518 2800	RWS 6045	S	24	1750	22,8	6,0	310	4500	31,0	17,8	13,3	11,5	25,3
6518 0900	RWS 6520	S	24	1750	24,8	6,6	138	2000	13,8	8,7	6,4	11,2	24,6
6518 1600	RWS 7020	S	24	1750	26,7	7,1	138	2000	13,8	9,8	7,2	11,2	24,6
6518 2000	RWS 8022	S	24	1750	30,0	7,9	152	2200	15,2	11,5	8,6	11,9	26,2
6518 2900	RWS 8025	S	24	1750	30,0	7,9	152	2200	15,2	11,5	8,6	11,9	26,2
6518 2100	RWS 8522	S	24	1750	33,0	8,7	152	2200	15,2	13,0	9,7	11,9	26,2
6518 2200	RWS 9518	S	24	1750	35,1	9,3	152	2200	15,2	13,5	10,1	11,9	26,2
6518 2300	RWS 10018	S	24	1750	38,0	10,1	124	1800	12,4	12,2	9,1	11,9	26,2

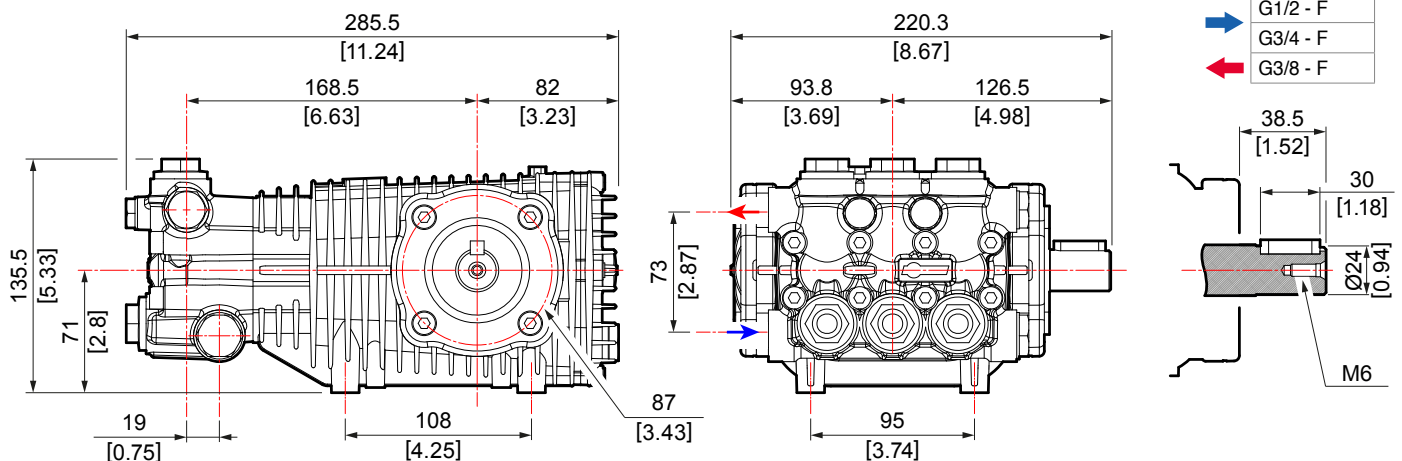



# RWS

**E** | Ø1"1/8

**PREMIUM**



ON REQUEST › SU RICHIESTA › BAJO PEDIDO



HOLLOW SHAFT Ø 1"1/8 › ALBERO FEMMINA Ø 1"1/8 › EJE HEMBRA Ø 1"1/8

Code Codice Codigo	Model Modello Modelo	Version	Ø	RPM	l/min	US gpm	Pressure			Power		Weight	
			"	rpm			bar	psi	Mpa	HP	kW	kg	lb
6518 0101	RWS 3030	E	1 1/8	1750	11,3	3,0	207	3000	20,7	6,0	4,4	11,2	24,6
6518 1700	RWS 3040	E	1 1/8	1750	11,3	3,0	276	4000	27,6	7,9	5,8	11,2	24,6
6518 0201	RWS 3530	E	1 1/8	1750	13,6	3,6	207	3000	20,7	7,2	5,3	11,2	24,6
6518 0401	RWS 4030	E	1 1/8	1750	15,0	4,0	207	3000	20,7	8,1	6,0	11,2	24,6
6518 1202	RWS 4040	E	1 1/8	1750	15,1	4,0	276	4000	27,6	10,5	7,8	11,2	24,6
6518 0501	RWS 4530	E	1 1/8	1750	16,7	4,4	207	3000	20,7	8,8	6,5	11,2	24,6
6518 0601	RWS 5030	E	1 1/8	1750	18,6	4,9	207	3000	20,7	9,8	7,2	11,2	24,6
6518 1402	RWS 5035	E	1 1/8	1750	18,6	4,9	241	3500	24,1	6,0	4,4	11,2	24,6
6518 0701	RWS 5530	E	1 1/8	1750	21,4	5,7	207	3000	20,7	11,2	8,3	11,2	24,6

## NEMA 182-184 TC

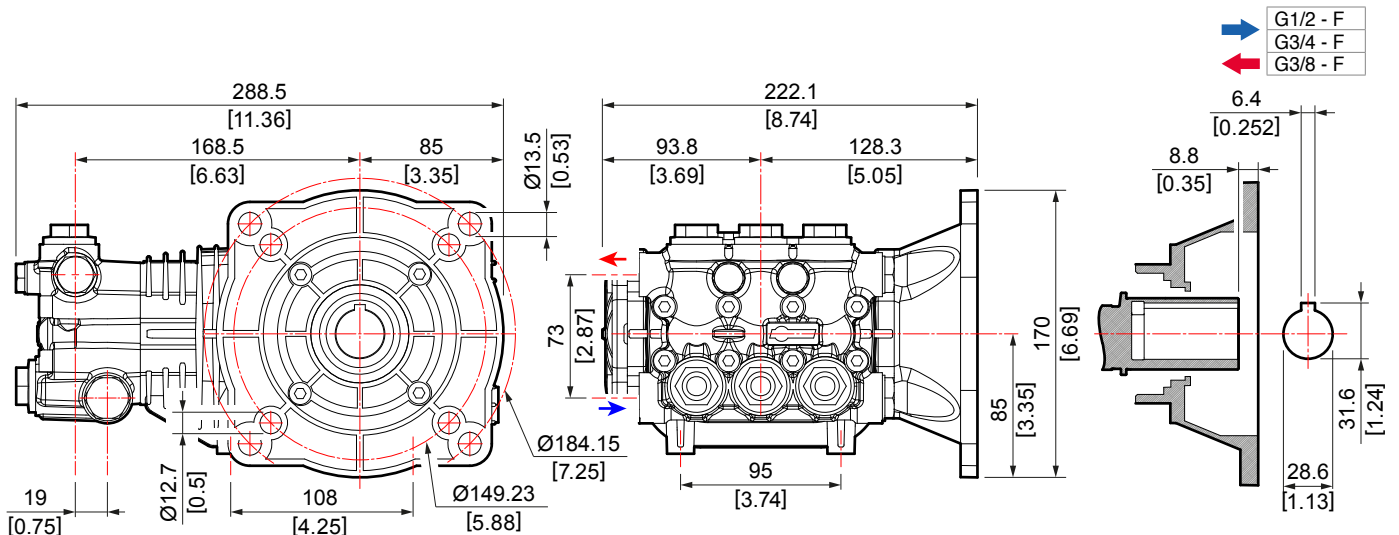

**ETW**

**S** | Ø30 mm

**ETWS**

**PREMIUM**

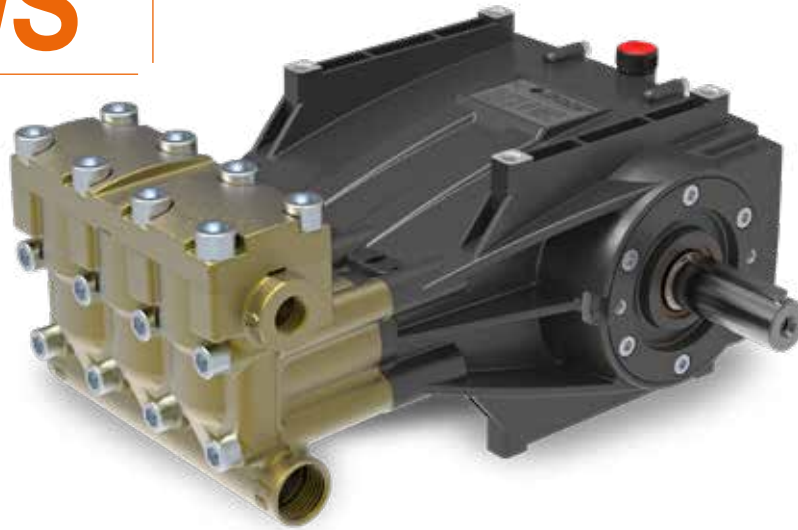

SOLID SHAFT Ø 30 mm › ALBERO MASCHIO Ø 30 mm › EJE MACHO Ø 30 mm

Code Codice Codigo	Model Modello Modelo	Version										
			mm	rpm	l/min	US gpm	bar	psi	HP	kW	kg	lb
6529 0001	ETW 8070	S	30	1450	29,9	7,90	500	7252	39,8	29,3	40	88,1
6529 0002	ETW 9558	S	30	1450	36,9	9,75	400	5801	39,3	28,9	40	88,1
6529 0003	ETW 12046	S	30	1450	44,6	11,79	320	4641	38,1	28,0	40	88,1
6530 0001	ETWS 9558	S	30	1750	36,1	9,53	400	5801	38,4	28,3	40	88,1
6530 0002	ETWS 12046	S	30	1750	44,5	11,76	320	4641	38,0	27,9	40	88,1
6530 0003	ETWS 14036	S	30	1750	53,9	14,23	250	3626	35,9	26,4	40	88,1

N.B. Theoretical flow rate at 100% volumetric efficiency /  
 N.B. Portate teoriche considerando il 100% dell'efficienza volumetrica.

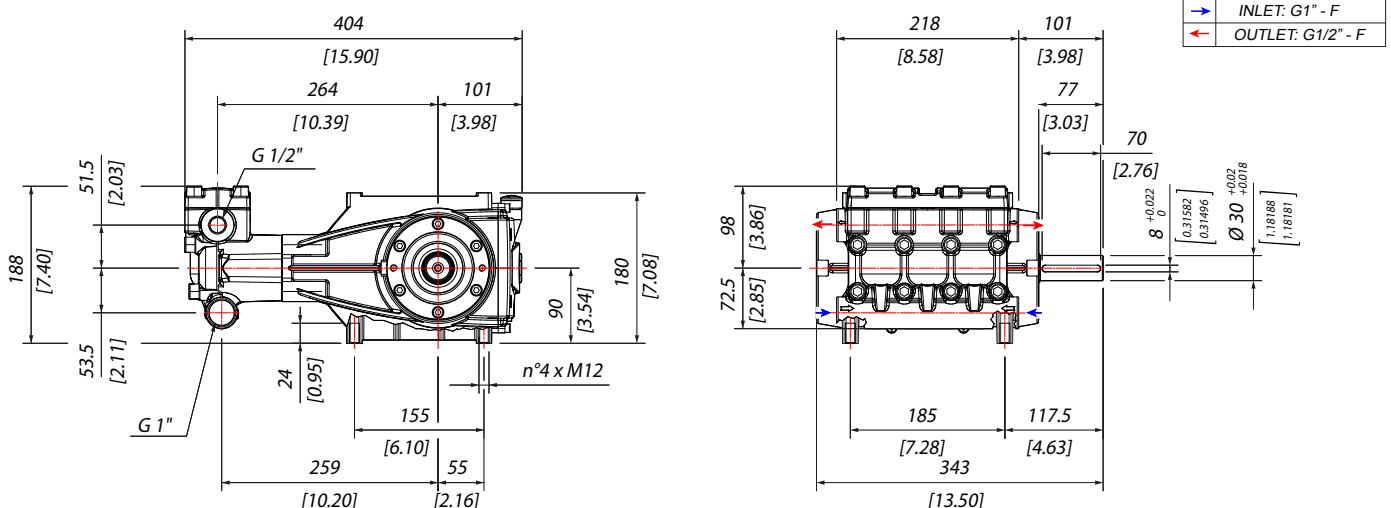

**TWN**

**TW**

**TWS**

**S** | Ø24 mm  
Ø30 mm

**PREMIUM**



SOLID SHAFT Ø 24 mm / Ø 30 mm › ALBERO MASCHIO Ø 24 mm / Ø 30 mm › EJE MACHO Ø 24 mm / Ø 30 mm

Code Codice Codigo	Model Modello Modelo	Version											
			mm	rpm	l/min	US gpm	bar	psi	Mpa	HP	kW	kg	lb
6512 0100	TWN 6036	S	24	1000	22,7	6,0	248	3600	24,8	14,0	10,3	20,0	44,0
6512 0300	TWN 8025	S	24	1000	30,0	8,0	172	2500	17,2	12,5	9,3	20,0	44,0
6513 2500	TW 4050	S	24	1450	14,8	3,9	345	5000	34,5	12,8	9,4	20,0	44,0
6513 0400	TW 4550	S	24	1450	17,8	4,7	345	5000	34,5	15,5	11,5	20,0	44,0
6513 1300	TW 5050	S	24	1450	20,0	5,2	345	5000	34,5	17,5	13,0	20,0	44,0
6513 0300	TW 5550	S	24	1450	22,0	5,8	345	5000	34,5	19,0	14,2	20,0	44,0
6513 0700	TW 7036	S	24	1450	26,6	7,0	248	3600	24,8	16,5	12,4	20,0	44,0
6513 3100	TW 7050	S	30	1450	24,9	6,6	345	5000	34,5	21,3	15,9	20,0	44,0
6513 1400	TW 8030	S	24	1450	32,9	8,7	207	3000	20,7	17,0	12,7	20,0	44,0
6513 0900	TW 8036	S	24	1450	32,6	8,6	248	3600	24,8	20,5	15,3	20,0	44,0
6513 1700	TW 8040	S	30	1450	32,6	8,6	276	4000	27,6	23,0	16,9	20,0	44,0
6513 3500	TW 8044	S	30	1450	32,6	8,6	303	4400	30,3	21,7	16,2	20,0	44,0
6513 1000	TW 10025	S	24	1450	38,0	10,0	172	2500	17,2	16,5	12,5	20,0	44,0
6513 1200	TW 11025	S	24	1450	42,5	11,0	172	2500	17,2	18,5	13,7	20,0	44,0
6513 1215	TW 11030	S	30	1450	42,2	11,2	207	3000	20,7	22,1	16,5	20,0	44,0
6513 2400	TW 13022	S	24	1450	48,5	12,8	152	2200	15,2	18,4	13,5	20,0	44,0
6513 2600	TW 14022	S	24	1450	53,5	14,1	152	2200	15,2	20,3	15,0	20,0	44,0
6513 2603	TW 14022	S	30	1450	53,5	14,1	152	2200	15,2	20,3	15,0	20,0	44,0
6514 1000	TWS 5050	S	24	1750	20,0	5,3	345	5000	34,5	17,5	13,1	20,0	44,0
6514 0100	TWS 5550	S	24	1750	21,2	5,6	345	5000	34,5	19,0	14,0	20,0	44,0
6514 0500	TWS 7040	S	24	1750	26,3	7,0	276	4000	27,6	18,5	16,6	20,0	44,0
6514 0600	TWS 8035	S	24	1750	31,5	8,3	241	3500	24,1	19,5	14,6	20,0	44,0
6514 0700	TWS 9030	S	24	1750	35,0	9,3	207	3000	20,7	19,0	14,0	20,0	44,0
6514 1100	TWS 10030	S	24	1750	40,5	10,7	207	3000	20,7	20,0	15,0	20,0	44,0
6514 0900	TWS 13020	S	24	1750	50,5	13,0	138	2000	13,8	12,2	9,0	20,0	44,0

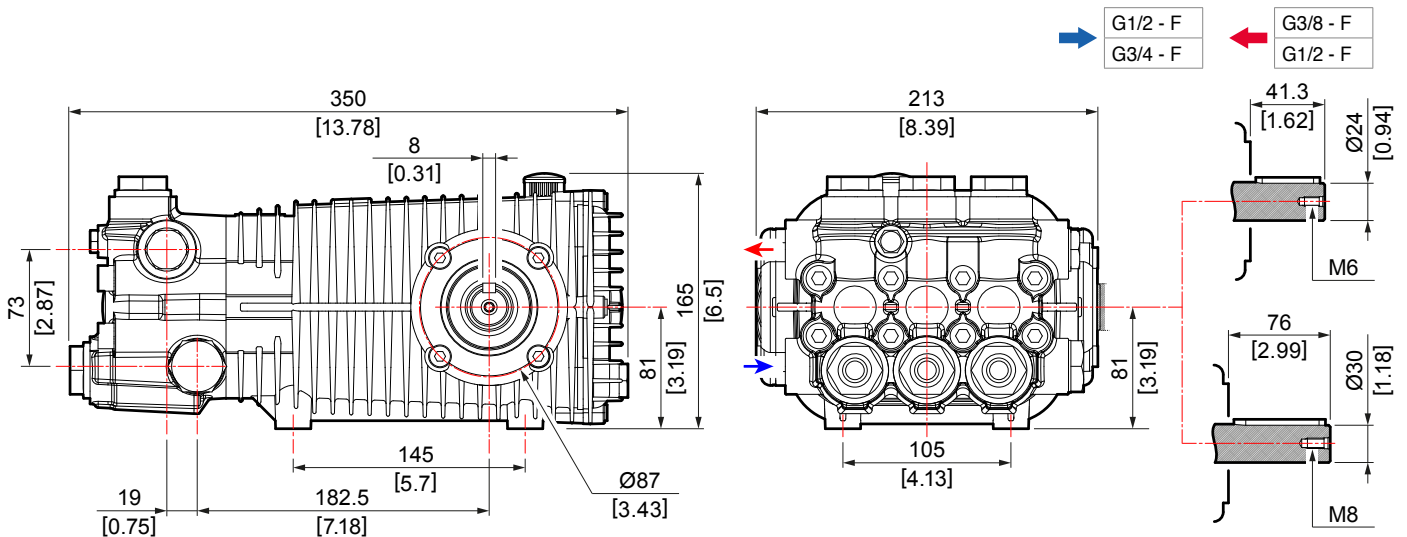



# TW 500



# TWS 500

**PREMIUM**

**NEW  
VERSION**



SOLID SHAFT Ø 24 mm / Ø 30 mm › ALBERO MASCHIO Ø 24 mm / Ø 30 mm › EJE MACHO Ø 24 mm / Ø 30 mm

Code Codice Codigo	Model Modello Modelo	Version											
			mm	rpm	l/min	US gpm	bar	psi	Mpa	HP	kW	kg	lb
6513 2801	TW 3073	S	24	1450	10,5	2,8	503	7300	50,3	13,3	9,9	23,5	51,8
6513 2001	TW 3573	S	24	1450	13,0	3,4	503	7300	50,3	16,5	12,1	23,5	51,8
6513 1809	TW 4073	S	24	1450	14,8	3,9	503	7300	50,3	18,8	13,8	23,5	51,8
6513 1808	TW 4073	S	30	1450	15,2	4,0	503	7300	50,3	19,3	14,2	23,5	51,8
6513 2108	TW 4573	S	24	1450	16,2	4,3	503	7300	50,3	20,2	14,9	23,5	51,8
6513 2107	TW 4573	S	30	1450	16,2	4,3	503	7300	50,3	20,2	14,9	23,5	51,8
6513 1904	TW 5073	S	30	1450	19,9	5,3	503	7300	50,3	25,2	18,6	23,5	51,8
6513 1504	TW 5573	S	30	1450	22,0	5,8	503	7300	50,3	27,9	20,5	23,5	51,8
6514 1201	TWS 4073	S	24	1750	15,7	4,1	503	7300	50,3	19,3	14,6	23,5	51,8
6514 1302	TWS 4573	S	30	1750	17,5	4,6	503	7300	50,3	22,1	16,3	23,5	51,8
6514 1402	TWS 5073	S	30	1750	18,4	4,9	503	7300	50,3	23,2	17,1	23,5	51,8
6514 1502	TWS 6073	S	30	1750	22,5	6,0	503	7300	50,3	28,5	21,0	23,5	51,8
6514 1602	TWS 7073	S	30	1750	26,7	7,0	503	7300	50,3	33,7	24,7	23,5	51,8

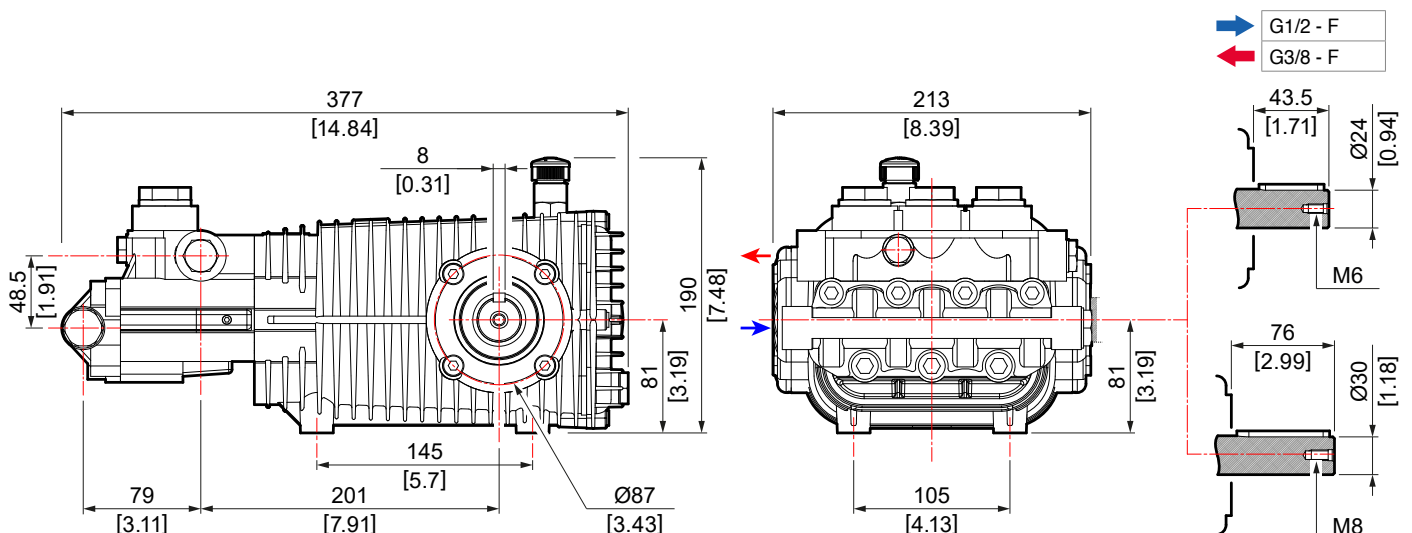



# TW 700



# TWS 700

**PREMIUM**



**FLUSHING SYSTEM**

**With Venturi recirculation of the cooling water in the head.**  
 Con ricircolo Venturi dell'acqua di raffreddamento in testata.  
 Con recirculación Venturi del agua de enfriamiento en la cabeza.

SOLID SHAFT Ø 30 mm › ALBERO MASCHIO Ø 30 mm › EJE MACHO Ø 30 mm

Code Codice Codigo	Model Modello Modelo	Version											
			mm	rpm	l/min	U.S.g.p.m.	bar	psi	Mpa	HP	kW	kg	lb
6513 3001	TW 35100	S	30	1450	12,9	3,4	700	10153	70,0	24,4	17,9	34,5	76,1
6513 2901	TW 40100	S	30	1450	14,2	3,8	700	10153	70,0	26,9	19,8	34,5	76,1
6514 2000	TWS 40100	S	30	1750	15,5	4,1	700	10153	70,0	29,4	21,6	34,5	76,1
6514 2100	TWS 45100	S	30	1750	17,1	4,5	700	10153	70,0	32,5	23,9	34,5	76,1

N.B. Theoretical flow rate at 100% volumetric efficiency. Pumps must always be operated with positive inlet pressure due to the standard flushing system. / N.B. Portata teorica al 100% del rendimento volumetrico. Le pompe devono essere sempre utilizzate con pressione positiva in ingresso a causa del sistema di flussaggio.

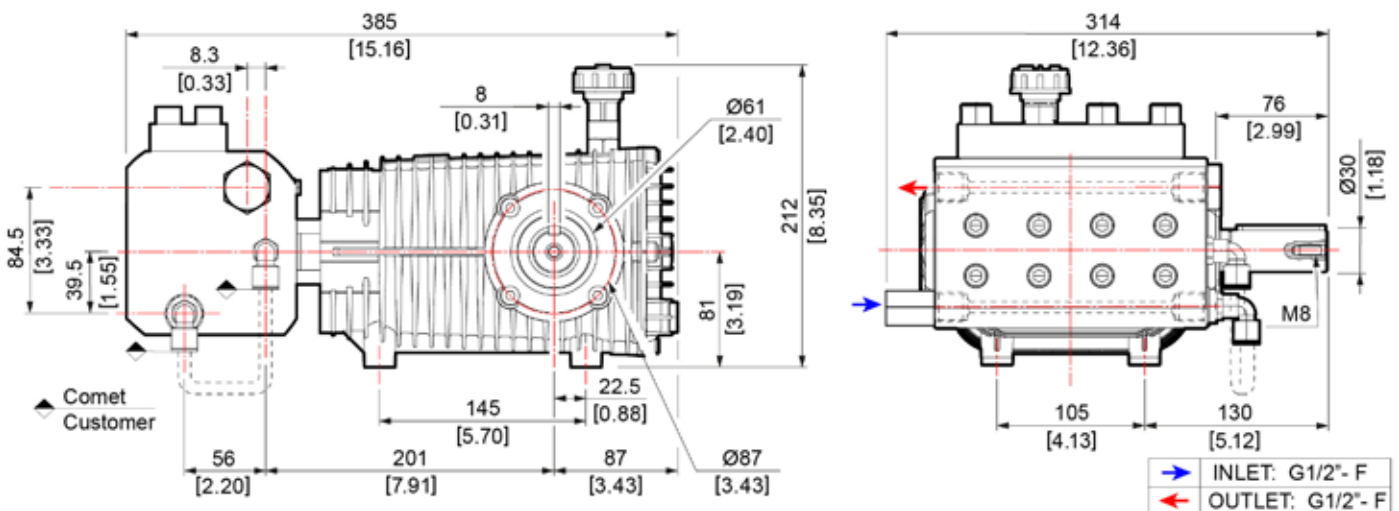



## ***PUMPS FOR HIGH TEMPERATURE WATER AND CARWASH PLANTS (85°C - 185°F)***

*POMPE PER ACQUA AD ELEVATA TEMPERATURA  
ED IMPIANTI CARWASH (85°C - 185°F)*

*BOMBAS PARA AGUA A ALTA TEMPERATURA  
EQUIPOS DE CARWASH (85°C - 185°F)*

---

Standard versions with p.t.o on right hand side, left side on request.

***Other flow / pressure combinations are available on request .***

Le versioni standard hanno la presa di forza sul lato destro, a richiesta sul lato sinistro.

***Altre combinazioni di portata e pressione sono disponibili su richiesta.***

Las versiones estándar tienen la toma de fuerza en el lado derecho, bajo pedido en el lado izquierdo.

***Otras combinaciones de caudal y presión están disponibles bajo pedido.***

nichtert

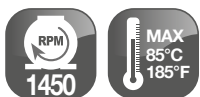

# FW2 Nickel



SOLID SHAFT Ø 24 mm · ALBERO MASCHIO Ø 24 mm · EJE MACHO Ø 24 mm

Code Codice Codigo	Model Modello Modelo	Version												
			Material	mm	rpm	l/min	US gpm	bar	psi	Mpa	HP	kW	kg	lb
6410 0127	FW2 4030	S	Nickel	24	1450	15,2	4,0	207	3000	20,7	7,9	5,9	8,8	19,4
6410 0411	FW2 5522	S	Nickel	24	1450	21,0	5,6	152	2200	15,2	7,9	5,9	8,8	19,4
6410 0505	FW2 5530	S	Nickel	24	1450	21,0	5,6	207	3000	20,7	10,8	8,0	8,8	19,4

Other nickel plated head versions available on request. / Altre versioni con testata nichelata disponibili su richiesta. / Otras versiones de cabeza niquelada disponibles bajo pedido.

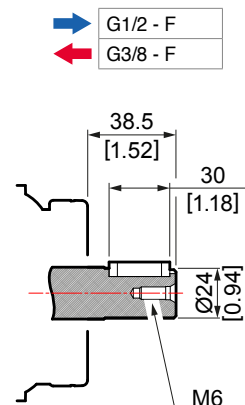
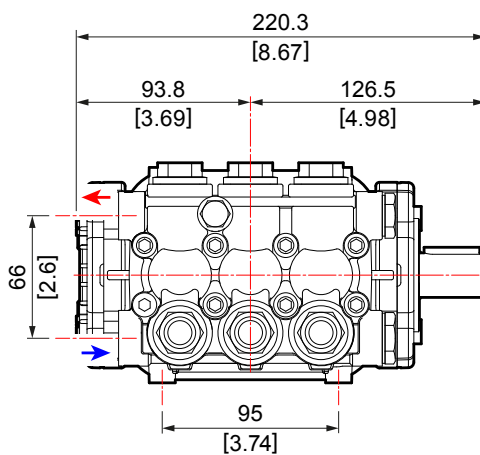
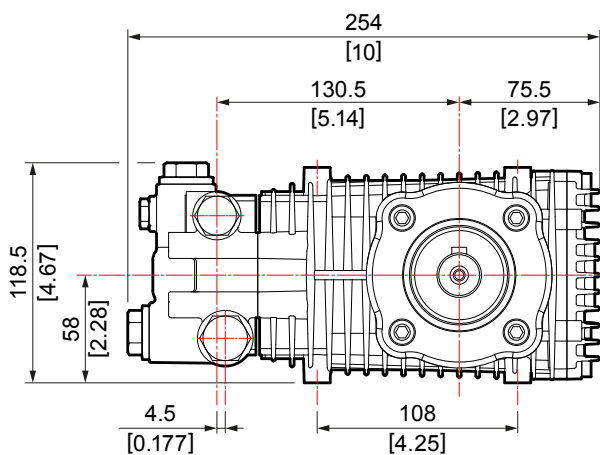





**ZW**

**S | Ø24 mm**



ON REQUEST › SU RICHIESTA › BAJO PEDIDO



**STAINLESS STEEL HEAD**  
TESTATA IN ACCIAIO INOX  
CABEZA EN ACERO INOX

SOLID SHAFT Ø 24 mm › ALBERO MASCHIO Ø 24 mm › EJE MACHO Ø 24 mm

Code Codice Codigo	Model Modello Modelo	Version											
			mm	rpm	l/min	US gpm	bar	psi	Mpa	HP	kW	kg	lb
6307 0802	ZW 3030	S	24	1450	12,3	3,2	207	3000	20,7	6,3	4,7	7,9	17,4
6307 1100	ZW 3530	S	24	1450	13,0	3,4	207	3000	20,7	6,5	4,9	7,9	17,4
6307 0503	ZW 4030	S	24	1450	15,0	4,0	207	3000	20,7	7,5	5,5	7,9	17,4

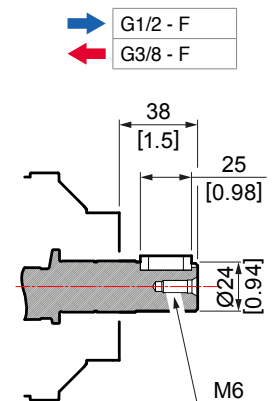
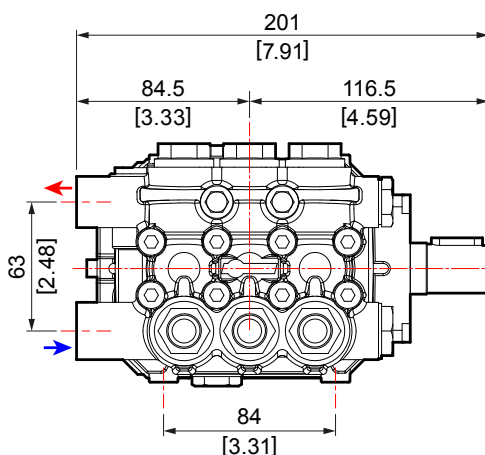
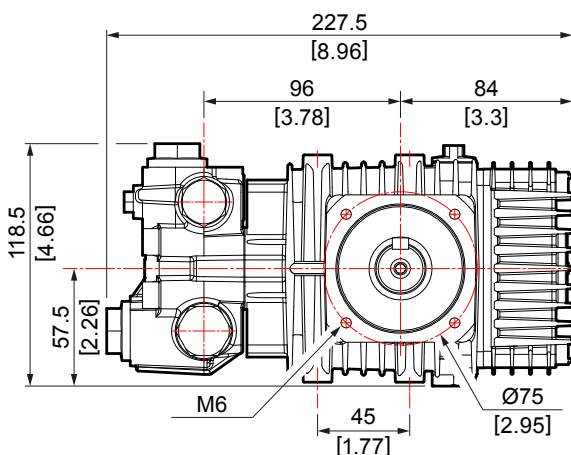

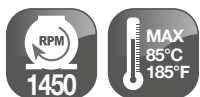

**RW**

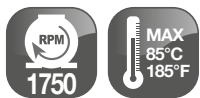

**RWS**



SOLID SHAFT Ø 24 mm › ALBERO MASCHIO Ø 24 mm › EJE MACHO Ø 24 mm

Code Codice Codigo	Model Modello Modelo	Version											
			mm	rpm	l/min	US gpm	bar	psi	Mpa	HP	kW	kg	lb
6517 0102	RW 4030	S	24	1450	15,6	4,1	207	3000	20,7	8,1	5,9	11,2	24,6
6517 0605	RW 5030	S	24	1450	18,8	5,0	207	3000	20,7	9,8	7,2	11,2	24,6
6517 0803	RW 5530	S	24	1450	20,8	5,3	207	3000	20,7	10,8	7,9	11,2	24,6
6517 1301	RW 5535	S	24	1450	20,8	5,3	241	3500	24,1	12,6	9,3	11,2	24,6
6517 0902	RW 6030	S	24	1450	23,4	6,2	207	3000	20,7	12,1	8,9	11,2	24,6
* 6518 1900	RWS 6035	S	24	1750	22,5	5,9	241	3500	24,1	13,8	10,2	11,2	24,6

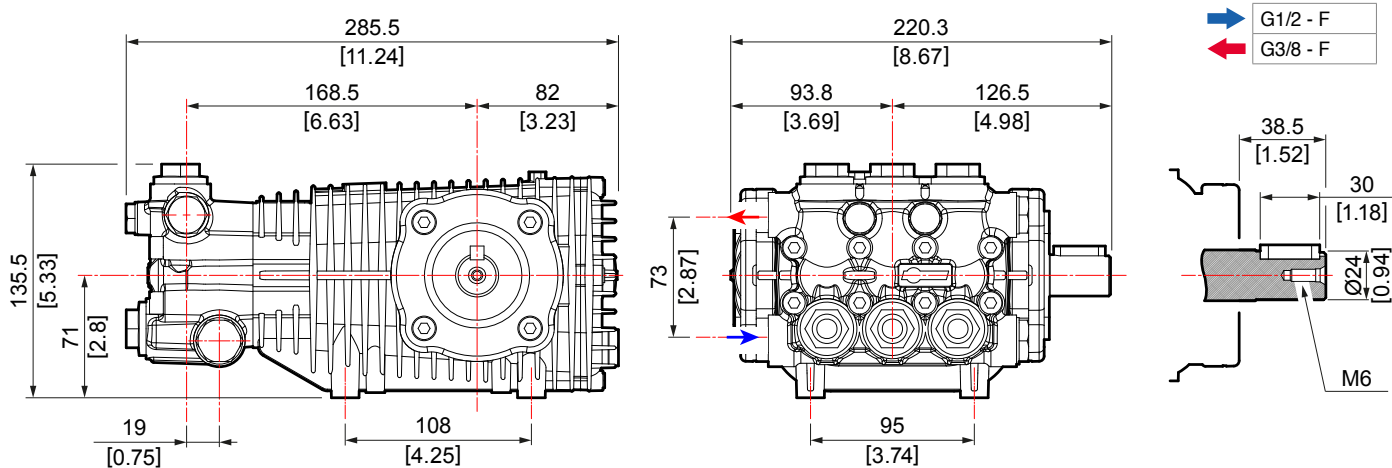

\* PTO shaft on left side. / \* Presa di forza su lato sinistro. / \* Toma de fuerza en el lado izquierdo.

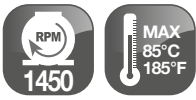

# RW Nickel



SOLID SHAFT Ø 24 mm > ALBERO MASCHIO Ø 24 mm > EJE MACHO Ø 24 mm

Code Codice Codigo	Model Modello Modelo	Version												
			Material	mm	rpm	l/min	US gpm	bar	psi	Mpa	HP	kW	kg	lb
6517 0301	RW 3530	S	Nickel	24	1450	13,0	3,4	207	3000	20,7	6,7	5,0	11,2	24,6
6517 0106	RW 4030	S	Nickel	24	1450	15,6	4,1	207	3000	20,7	8,1	6,0	11,2	24,6
6517 0809	RW 5535	S	Nickel	24	1450	20,6	5,4	241	3500	24,1	11,9	8,9	11,2	24,6

Other nickel plated head versions available on request. / Altre versioni con testata nichelata disponibili su richiesta. / Otras versiones de cabeza niquelada disponibles bajo pedido.

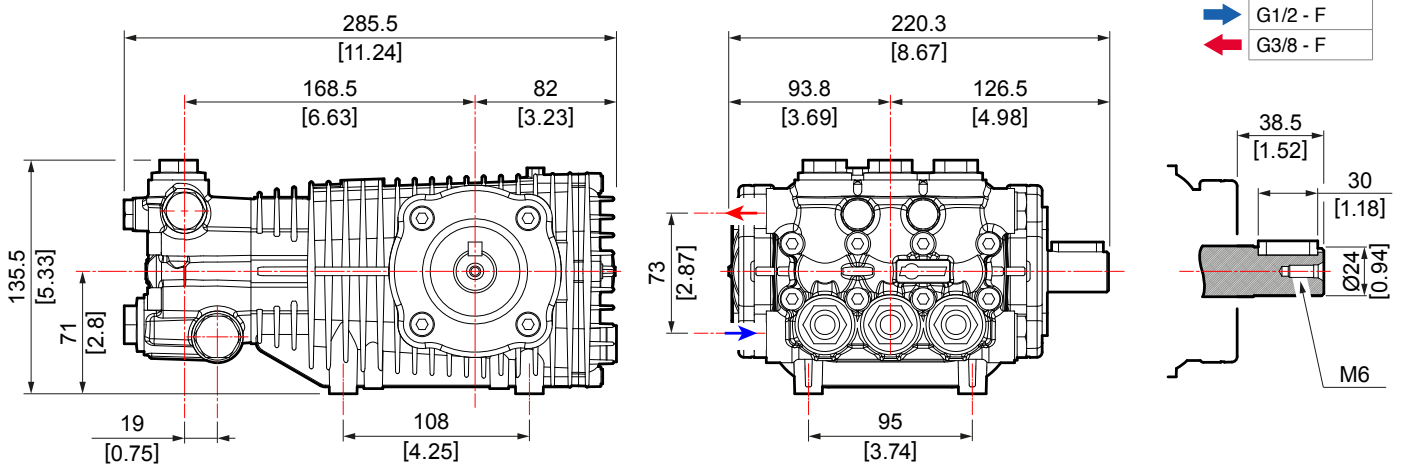

\* PTO shaft on left side. / \* Presa di forza su lato sinistro. / \* Toma de fuerza en el lado izquierdo.

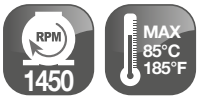

**TW**

**S | Ø24 mm**



SOLID SHAFT Ø 24 mm › ALBERO MASCHIO Ø 24 mm › EJE MACHO Ø 24 mm

Code Codice Codigo	Model Modello Modelo	Version											
			mm	rpm	l/min	US gpm	bar	psi	Mpa	HP	kW	kg	lb
6513 0704	TW 7036	S	24	1450	26,6	7,0	248	3600	24,8	16,5	12,4	20,0	44,0
6513 1401	TW 8030	S	24	1450	32,9	8,7	207	3000	20,7	17,0	12,7	20,0	44,0
6513 0902	TW 8036	S	24	1450	32,6	8,6	248	3600	24,8	20,5	15,3	20,0	44,0
6513 1001	TW 10025	S	24	1450	38,0	10,0	172	2500	17,2	16,5	12,3	20,0	44,0
6513 1201	TW 11025	S	24	1450	42,5	11,2	172	2500	17,2	18,5	13,7	20,0	44,0

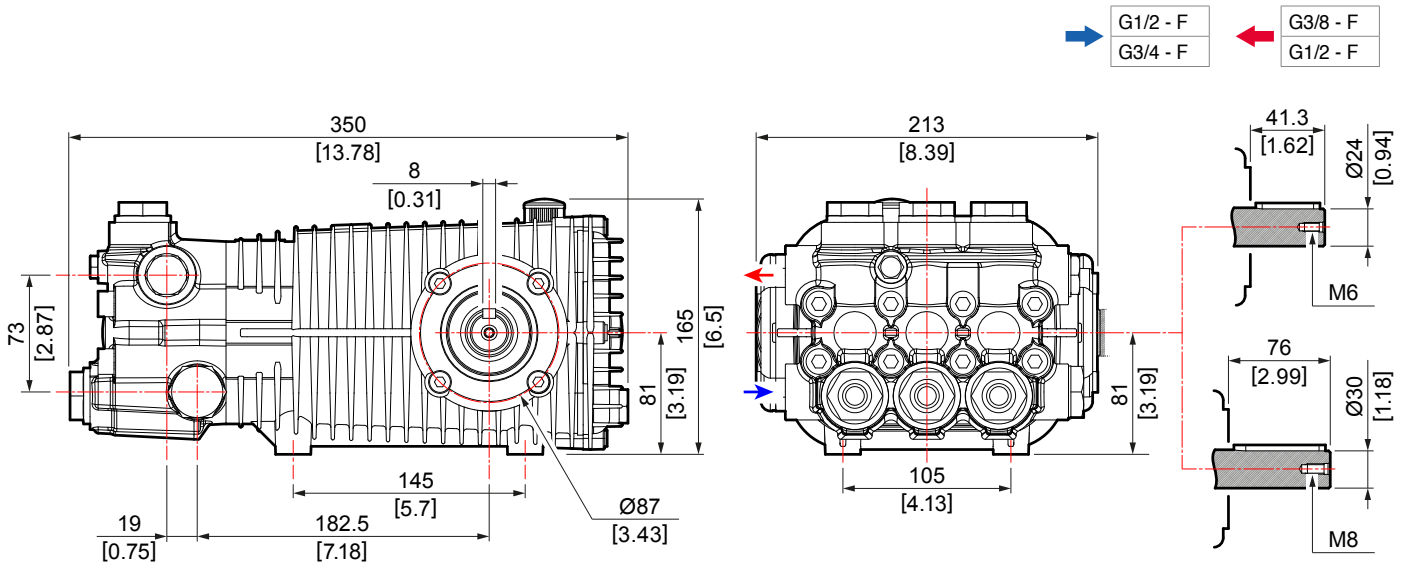

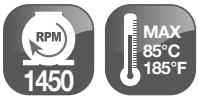

# TW Nickel



SOLID SHAFT Ø 24 mm > ALBERO MASCHIO Ø 24 mm > EJE MACHO Ø 24 mm

Code Codice Codigo	Model Modello Modelo	Version												
			Material	mm	rpm	l/min	US gpm	bar	psi	Mpa	HP	kW	kg	lb
6513 1004	TW 10025 S	Nickel	24	1450	38,0	10,0	172	2500	17,2	16,5	12,3	20,0	44,0	
6513 1205	TW 11025 S	Nickel	24	1450	42,5	11,2	172	2500	17,2	18,5	13,7	20,0	44,0	

Other nickel plated head versions available on request. / Altre versioni con testata nichelata disponibili su richiesta. / Otras versiones de cabeza niquelada disponibles bajo pedido.

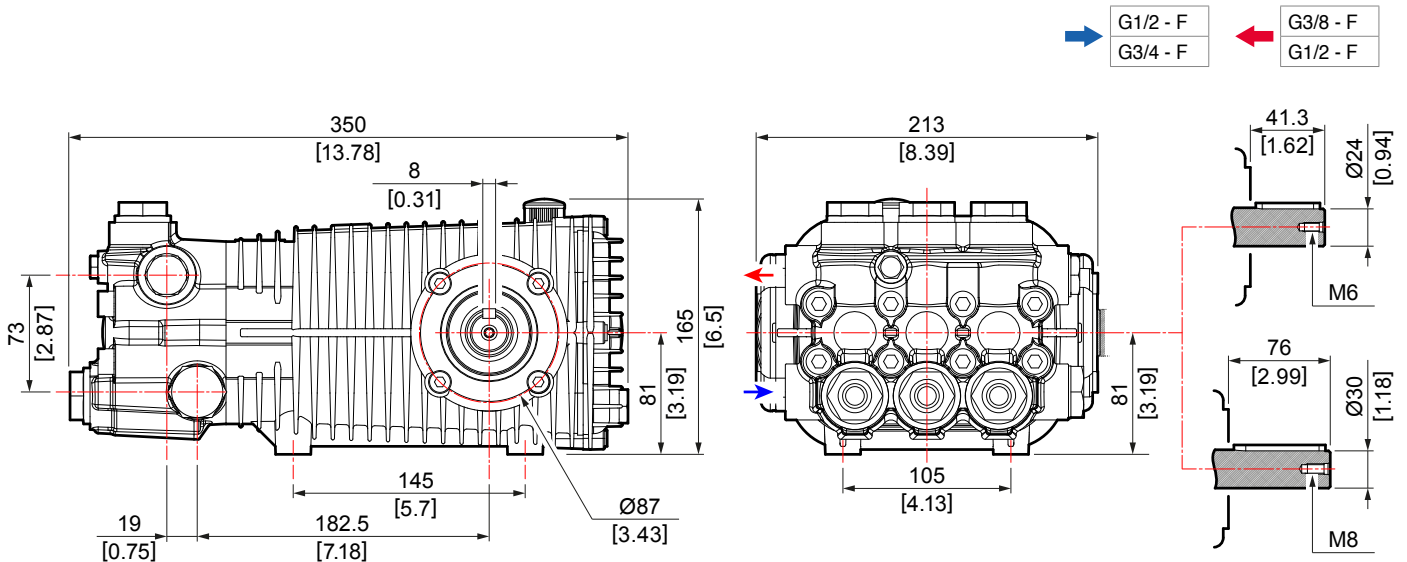



## **PUMPS FOR DIRECT APPLICATION TO HYDRAULIC MOTORS**

*POMPE PER APPLICAZIONE DIRETTA*

*A MOTORE IDRAULICO*

*BOMBAS PARA APLICACIÓN DIRECTA*

*EN MOTOR HIDRÁULICO*

All models are supplied with brass head.

Standard versions with p.t.o on right hand side, left side on request.

***Other flow / pressure combinations are available on request .***

Tutti i modelli sono forniti con testata in ottone.

Le versioni standard hanno la presa di forza sul lato destro, a richiesta sul lato sinistro.

***Altre combinazioni di portata e pressione sono disponibili su richiesta.***

Todos los modelos están disponibles con cabeza de latón.

Las versiones estándar tienen la toma de fuerza en el lado derecho, bajo pedido en el lado izquierdo.

***Otras combinaciones de caudal y presión están disponibles bajo pedido.***

# Hydrau



HOLLOW SHAFT Ø 5/8" > ALBERO FEMMINA Ø 5/8" > EJE HEMBRA Ø 5/8"

Code Codice Codigo	Model Modello Modelo	Version											
			"	rpm	l/min	US gpm	bar	psi	Mpa	HP	kW	kg	lb
6307 0502	ZW 4030	H	5/8	1450	15,0	4,0	207	3000	20,7	7,5	5,5	8,0	17,6

SAE A

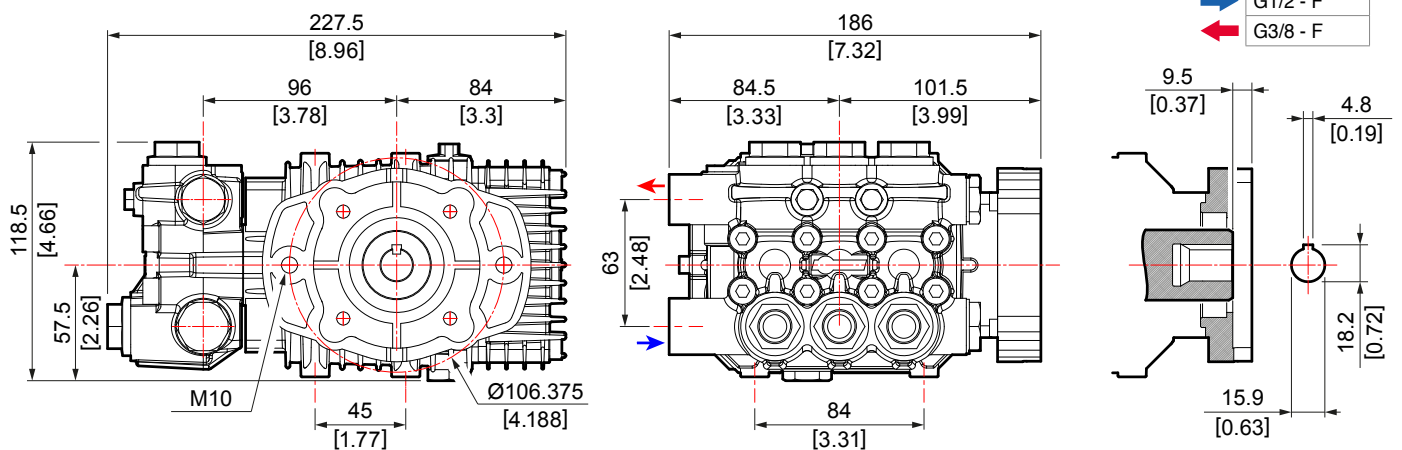



FW2

H | Ø 5/8"



HOLLOW SHAFT Ø 5/8" › ALBERO FEMMINA Ø 5/8" › EJE HEMBRA Ø 5/8"

Code Codice Codigo	Model Modello Modelo	Version											
			"	rpm	l/min	US gpm	bar	psi	Mpa	HP	kW	kg	lb
6410 0606	FW2 4022	H	5/8	1450	15,4	4,1	152	2200	15,2	5,5	4,0	9,3	20,5
6410 0122	FW2 4030	H	5/8	1450	15,2	4,0	207	3000	20,7	7,5	5,5	9,3	20,5
6410 0415	FW2 5016	H	5/8	1450	18,8	5,0	110	1600	11,0	5,2	3,9	9,3	20,5

SAE A

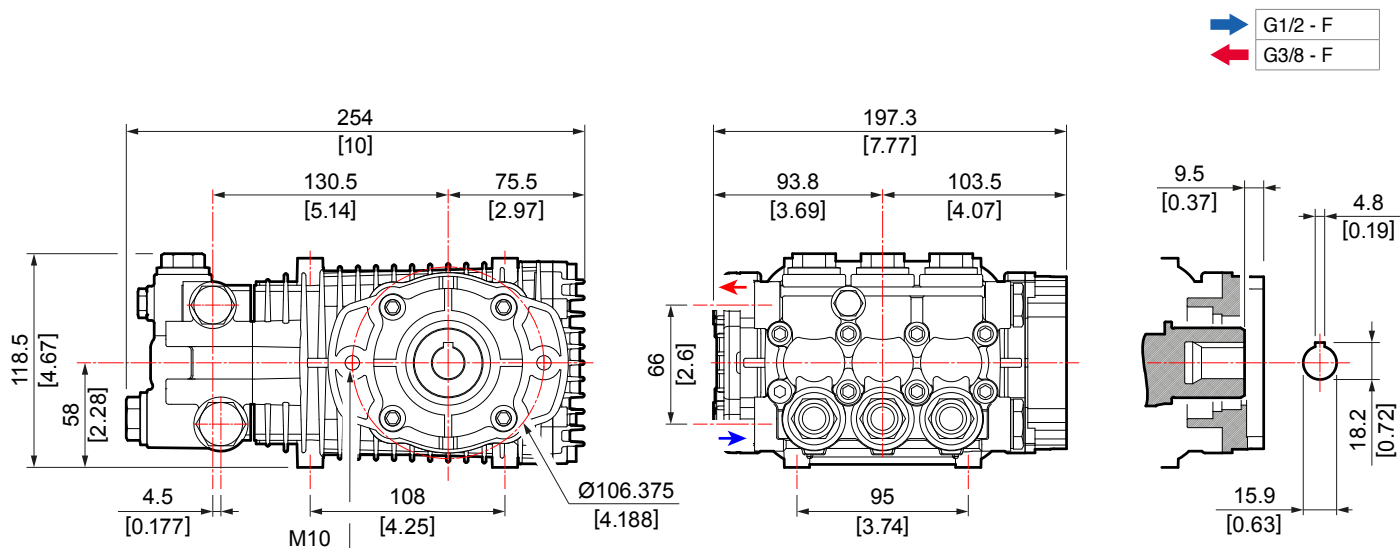





HOLLOW SHAFT Ø 5/8" > ALBERO FEMMINA Ø 5/8" > EJE HEMBRA Ø 5/8"

Code Codice Codigo	Model Modello Modelo	Version											
			"	rpm	l/min	US gpm	bar	psi	Mpa	HP	kW	kg	lb
6513 5000	TW 8020	H	5/8	1450	33,0	8,7	138	2000	13,8	11,4	8,4	21,0	46,2

SAE A

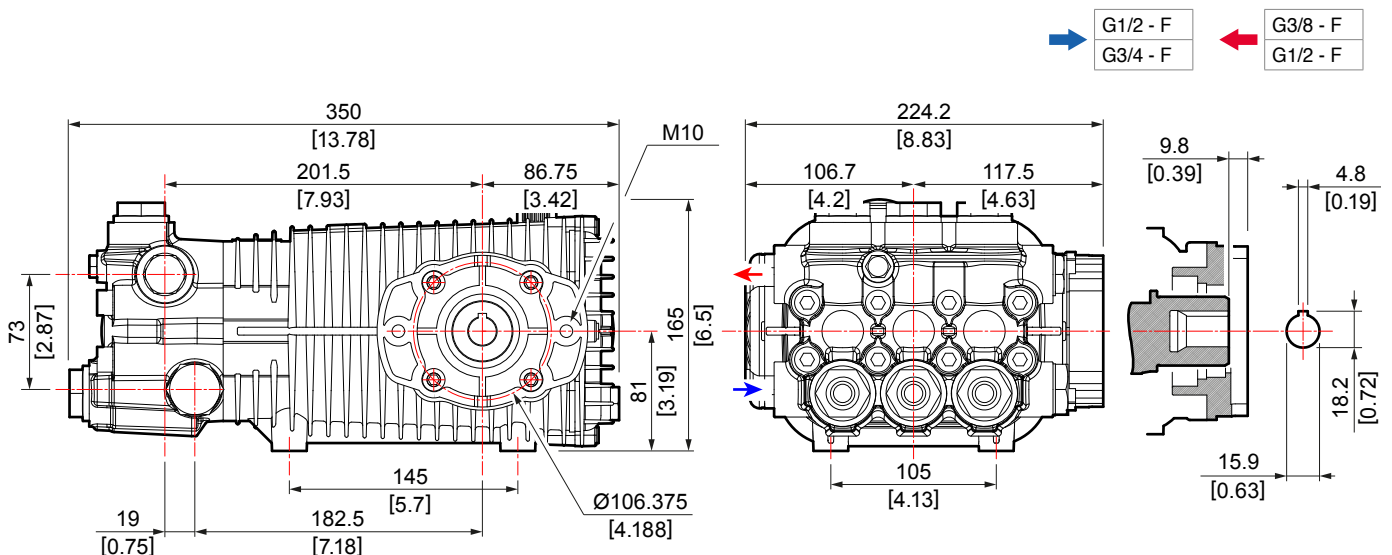



## **AXIAL PISTON PUMPS**

*POMPE A PISTONI ASSIALI*

*BOMBAS DE PISTONES AXIALES*

---

All models are supplied with brass head.

***Other flow / pressure combinations are available on request .***

Tutti i modelli sono forniti con testata in ottone.

***Altre combinazioni di portata e pressione sono disponibili su richiesta.***

Todos los modelos están disponibles con cabeza de latón.

***Otras combinaciones de caudal y presión están disponibles bajo pedido.***

# Axial



CYLINDRICAL HOLLOW SHAFT Ø 7/8" › ALBERO CILINDRICO FEMMINA Ø 7/8" › EJE CILÍNDRICO Ø 7/8"

Code Codice Codigo	Model Modello Modelo	Version		Shaft Length Lunghezza Albero Largo del eje										
			Ø		rpm	l/min	US gpm	bar	psi	Mpa	HP	kW	kg	lb
* 6511 0023	VRX 2017	V	7/8	80,0	3200	8,0	2,1	110	1600	11,0	2,6	1,9	2,4	5,3
* 6511 0024	VRX 2017	V	7/8	46,0	3200	8,0	2,1	110	1600	11,0	2,6	1,9	2,4	5,3
6511 0003	VRX 2022	V	7/8	80,0	3200	8,0	2,1	152	2200	15,2	3,5	2,6	3,5	7,7
6511 0004	VRX 2022	V	7/8	46,0	3200	8,0	2,1	152	2200	15,2	3,5	2,6	3,5	7,7
6511 0009	VRX 2522	V	7/8	80,0	3200	9,1	2,4	152	2200	15,2	4,0	2,9	3,5	7,7

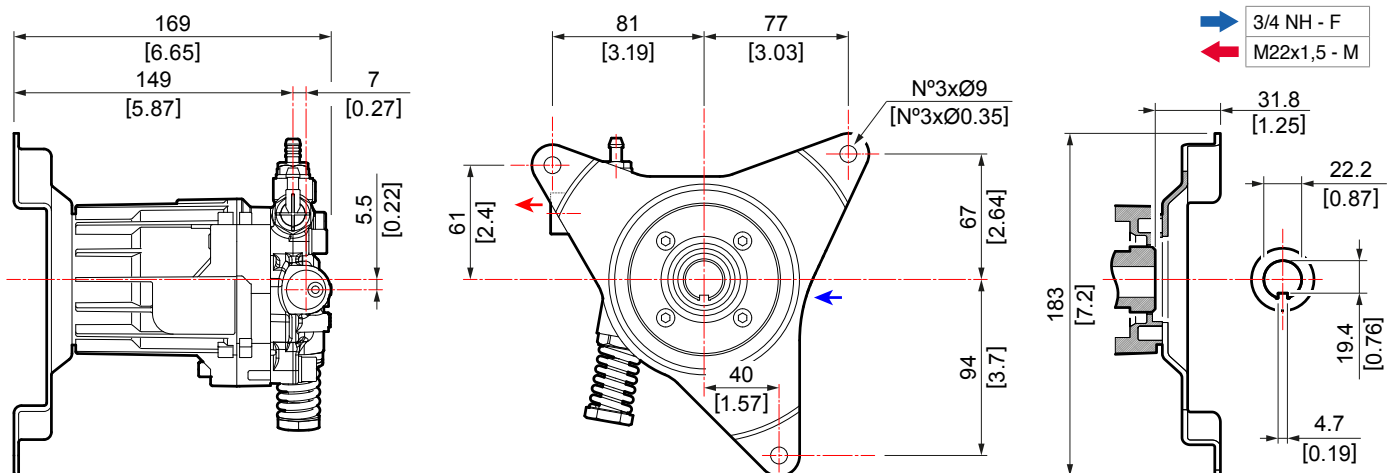

The models marked with \* are supplied with aluminum head. / I modelli contrassegnati con \* sono forniti con testata in alluminio. / Los modelos marcados con \* están disponibles con cabeza de aluminio.



HOLLOW SHAFT Ø 3/4" › ALBERO FEMMINA Ø 3/4" › EJE HEMBRA Ø 3/4"

Code Codice Codigo	Model Modello Modelo	Version	Ø	RPM	Flow			Pressure			Power		Weight	
			"	rpm	l/min	US gpm	bar	psi	Mpa	HP	kW	kg	lb	
6511 0005	VRX 2522	G	3/4	3400	9,5	2,5	152	2200	15,2	4,2	3,1	3,3	7,3	
6511 0015	VRX 2524	G	3/4	3400	9,5	2,5	165	2400	16,5	4,4	3,3	3,5	7,7	
6511 0025	VRX 2527	G	3/4	3400	9,5	2,5	186	2700	18,6	5,1	3,8	3,5	7,7	

SAE J 609 A

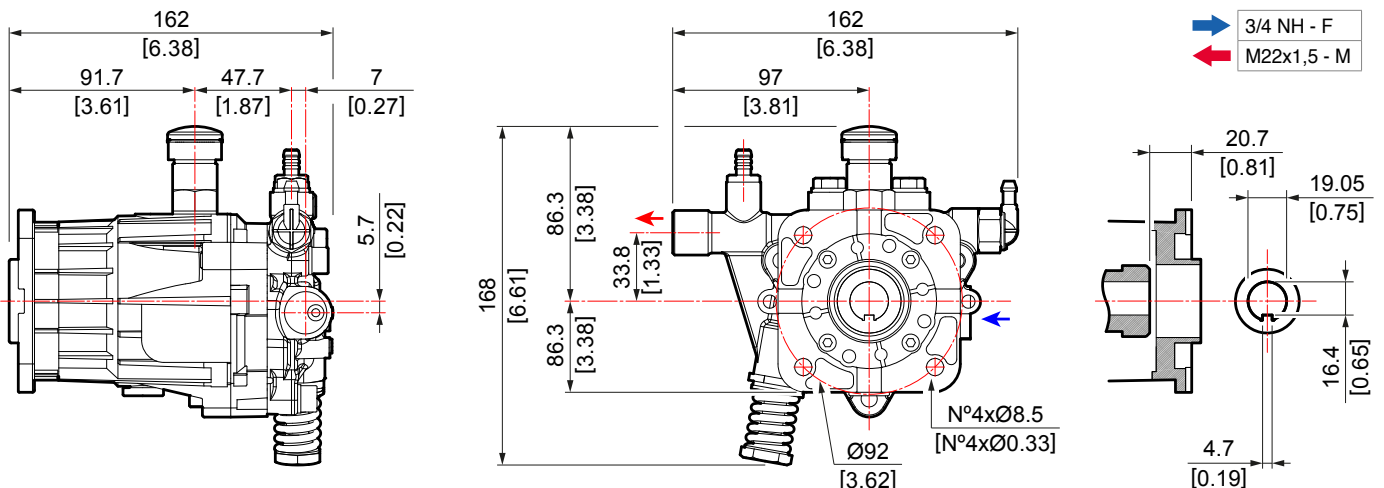



HOLLOW SHAFT Ø 3/4" › ALBERO FEMMINA Ø 3/4" › EJE HEMBRA Ø 3/4"

Code Codice Codigo	Model Modello Modelo	Version	Ø	RPM	l/min	US gpm	Pressure			Power		Weight	
			"	rpm			bar	psi	Mpa	HP	kW	kg	lb
● 6525 1006	BXD 2220	G	3/4	3400	8,4	2,2	138	2000	13,8	3,4	2,5	4,7	10,3
▲ 6525 1003	BXD 2220	G	3/4	3400	8,4	2,2	138	2000	13,8	3,4	2,5	4,7	10,3
▲ 6525 1001	BXD 2525	G	3/4	3400	8,5	2,3	165	2500	16,5	4,2	3,1	4,7	10,3
● 6525 1007	BXD 2527	G	3/4	3400	9,0	2,4	185	2700	18,5	4,8	3,6	4,7	10,3
▲ 6525 1002	BXD 2527	G	3/4	3400	9,0	2,4	185	2700	18,5	4,8	3,6	4,7	10,3
● 6525 1008	BXD 3020	G	3/4	3400	10,6	2,8	138	2000	13,8	4,2	3,1	4,7	10,3
▲ 6525 1004	BXD 3020	G	3/4	3400	10,6	2,8	138	2000	13,8	4,2	3,1	4,7	10,3
● 6525 1009	BXD 3025	G	3/4	3400	11,1	2,9	135	2500	13,5	5,1	4,2	4,7	10,3
▲ 6525 1005	BXD 3025	G	3/4	3400	11,1	2,9	135	2500	13,5	5,1	4,2	4,7	10,3

SAE J 609 A

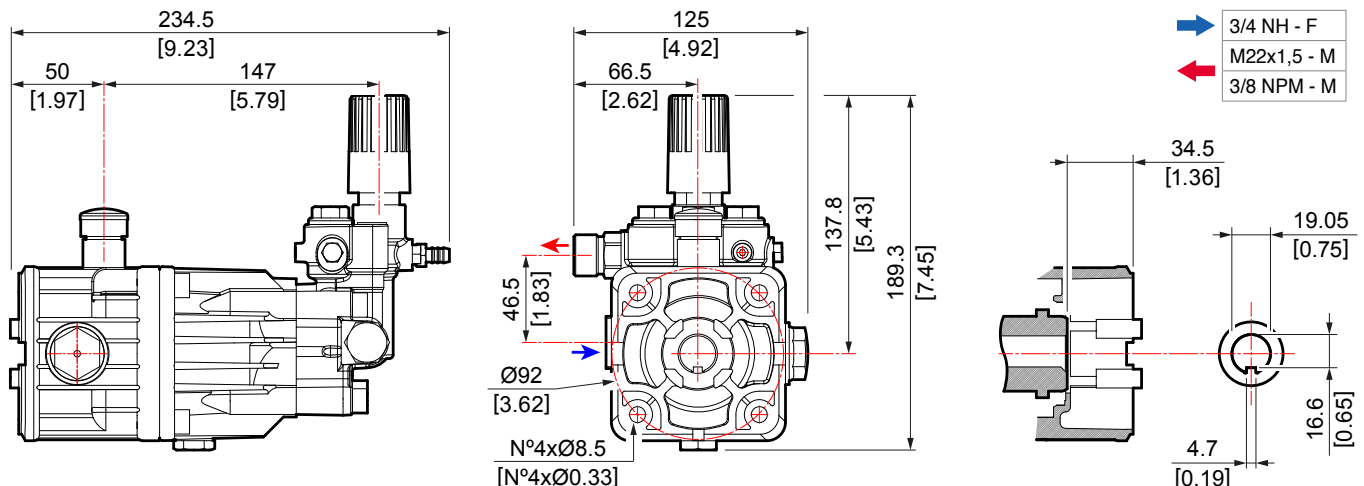

- ▲ Outlet connection 3/8 NPT / Connessione uscita 3/8 NPT / Conexión salida 3/8 NPT
- Outlet connection M22x1,5 / Connessione uscita M22x1,5 / Conexión salida M22x1,5

All models are equipped with **EASY-START** device. / Tutti i modelli sono dotati di dispositivo **EASY-START**. / Todos los modelos están equipados con el dispositivo **EASY-START**.



# BXD



E | Ø 5/8"



HOLLOW SHAFT Ø 5/8" › ALBERO FEMMINA Ø 5/8" › EJE HEMBRA Ø 5/8"

Code Codice Codigo	Model Modello Modelo	Version	Ø	RPM	Flow		Pressure			Power		Weight	
			"	rpm	l/min	US gpm	bar	psi	Mpa	HP	kW	kg	lb
▲ 6525 1010	BXD 2020	E	5/8	3400	7,2	1,9	138	2000	13,8	2,9	2,1	4,7	10,3
▲ 6525 1011	BXD 2520	E	5/8	3400	9,6	2,5	138	2000	13,8	3,8	2,8	4,7	10,3
▲ 6525 1012	BXD 3020	E	5/8	3400	10,6	2,8	138	2000	13,8	4,2	3,1	4,7	10,3

## NEMA 56 C

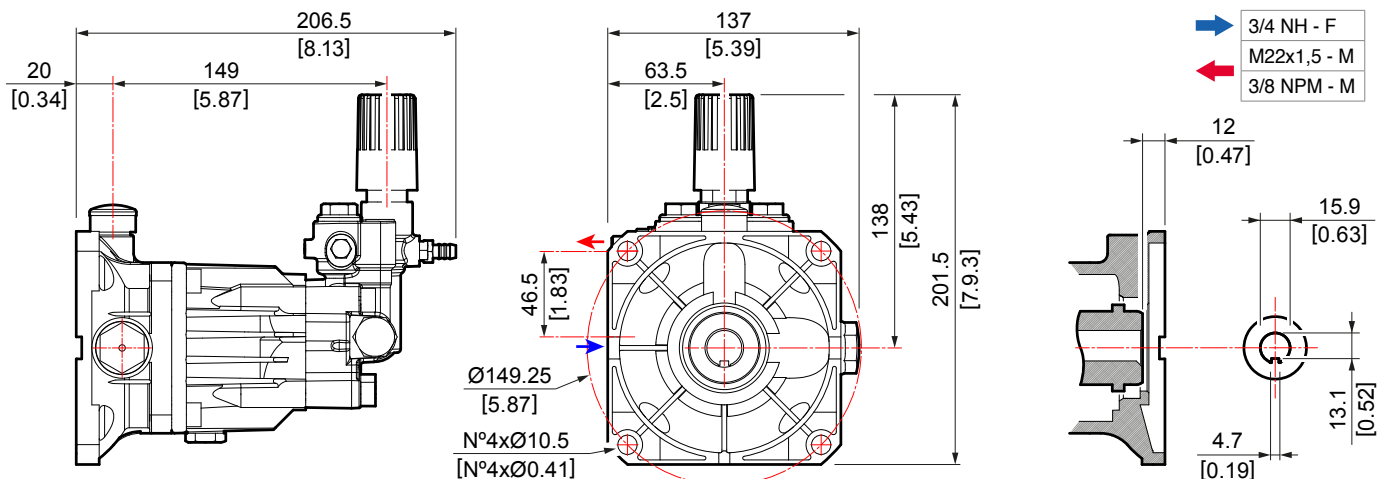

▲ Outlet connection 3/8 NPT / Connezione uscita 3/8 NPT / Coneccion salida 3/8 NPT

All models are equipped with **EASY-START** device. / Tutti i modelli sono dotati di dispositivo **EASY-START**. / Todos los modelos están equipados con el dispositivo **EASY-START**.



HOLLOW SHAFT Ø 3/4" › ALBERO FEMMINA Ø 3/4" › EJE HEMBRA Ø 3/4"

Code Codice Codigo	Model Modello Modelo	Version	Ø	RPM	l/min	US gpm	Pressure			Power		Weight	
			"	rpm			bar	psi	Mpa	HP	kW	kg	lb
▲ 6501 0015	*AXD 2516	G	3/4	3400	9,0	2,4	110	1600	11,0	2,9	2,1	4,1	9,0
▲ 6501 0018	AXD 2518	G	3/4	3400	9,6	2,5	114	1650	11,4	3,0	2,2	5,3	11,7
● 6501 0002	AXD 2520	G	3/4	3400	9,6	2,5	138	2000	13,8	3,8	2,8	5,3	11,7
▲ 6501 0025	AXD 2527	G	3/4	3400	9,6	2,5	186	2700	18,6	5,2	3,8	5,3	11,7
● 6501 0001	AXD 3020	G	3/4	3400	10,2	2,7	138	2000	13,8	4,1	3,0	5,3	11,7
▲ 6501 0005	AXD 3020	G	3/4	3400	10,2	2,7	138	2000	13,8	4,1	3,0	5,3	11,7
● 6501 0004	AXD 3025	G	3/4	3400	10,8	2,9	172	2500	17,2	5,4	4,0	5,3	11,7
▲ 6501 0006	AXD 3025	G	3/4	3400	10,8	2,9	172	2500	17,2	5,4	4,0	5,3	11,7
● 6501 0003	AXD 3522	G	3/4	3400	12,7	3,3	152	2200	15,2	5,6	4,1	5,3	11,7
▲ 6501 0008	AXD 3522	G	3/4	3400	12,7	3,3	152	2200	15,2	5,6	4,1	5,3	11,7
● 6501 0017	AXD 3525	G	3/4	3400	12,7	3,3	172	2500	17,2	6,3	4,6	5,3	11,7

SAE J 609 A

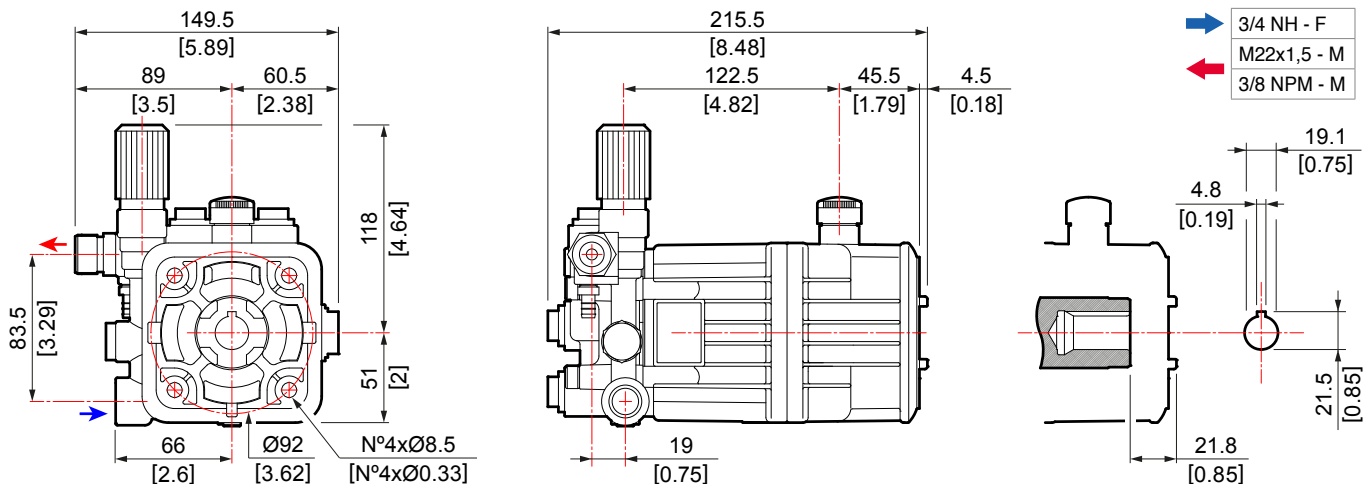

- ▲ Outlet connection 3/8 NPT / Connezione uscita 3/8 NPT / Coneccion salida 3/8 NPT
- Outlet connection M22x1,5 / Connezione uscita M22x1,5 / Coneccion salida M22x1,5

The models marked with \* are supplied with aluminum head. / I modelli contrassegnati con \* sono forniti con testata in alluminio. / Los modelos marcados con \* están disponibles con cabeza de aluminio.



HOLLOW SHAFT Ø 5/8" › ALBERO FEMMINA Ø 5/8" › EJE HEMBRA Ø 5/8"

Code Codice Codigo	Model Modello Modelo	Version	Ø	RPM	l/min	US gpm	Pressure			Power		Weight	
			"	rpm			bar	psi	Mpa	HP	kW	kg	lb
▲ 6501 0021	* AXD 2010	E	5/8	3400	7,2	1,9	69	1000	6,9	1,4	1,0	4,1	9,0
▲ 6501 0010	AXD 2020	E	5/8	3400	7,2	1,9	138	2000	13,8	2,9	2,1	5,3	11,7
▲ 6501 0012	AXD 2520	E	5/8	3400	9,6	2,5	138	2000	13,8	3,8	2,8	5,3	11,7
▲ 6501 0013	AXD 3020	E	5/8	3400	10,8	2,9	138	2000	13,8	4,3	3,2	5,3	11,7

NEMA 56 C

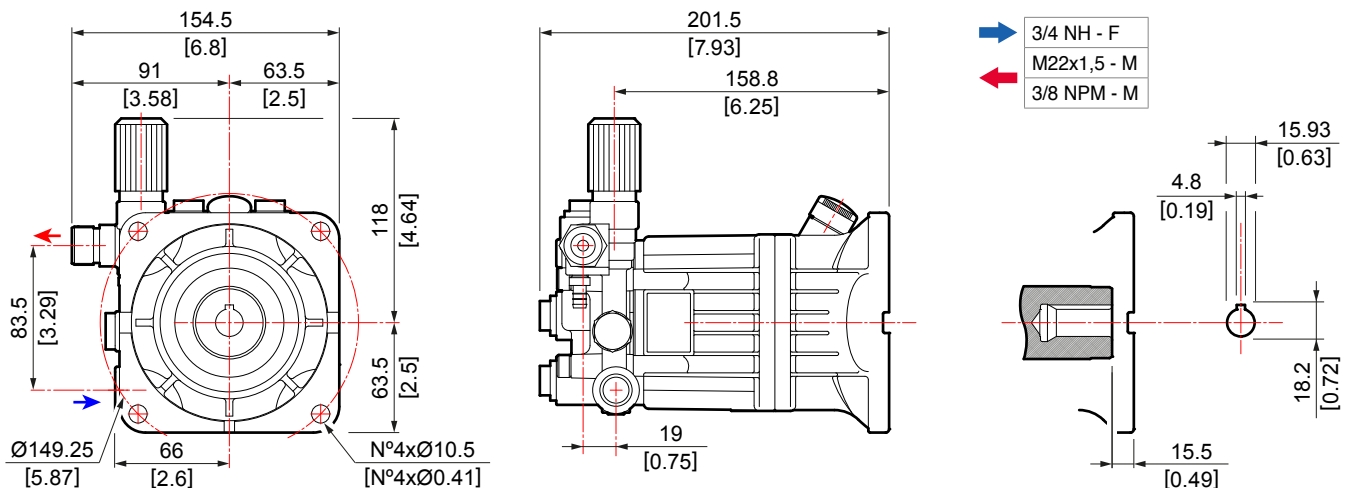

▲ Outlet connection 3/8 NPT / Connessione uscita 3/8 NPT / Coneccion salida 3/8 NPT

The models marked with \* are supplied with aluminum head. / I modelli contrassegnati con \* sono forniti con testata in alluminio. / Los modelos marcados con \* están disponibles con cabeza de aluminio.





**CXD**



**G** | Ø 3/4"



HOLLOW SHAFT Ø 3/4" › ALBERO FEMMINA Ø 3/4" › EJE HEMBRA Ø 3/4"

Code Codice Codigo	Model Modello Modelo	Version											
			“	rpm	l/min	US gpm	bar	psi	Mpa	HP	kW	kg	lb
6527 0001	* CXD 2223	G	3/4	3400	8,3	2,2	159	2300	15,9	3,8	2,8	2,1	4,6
6527 0007	* CXD 2227	G	3/4	3400	8,3	2,2	185	2700	18,5	4,4	3,3	2,1	4,6
6527 0002	CXD 2225	G	3/4	3400	8,3	2,2	172	2500	17,2	4,1	3,0	2,9	6,4
6527 0005	CXD 2526	G	3/4	3400	9,1	2,4	179	2600	17,9	4,7	3,5	2,9	6,4
6527 0004	CXD 2530	G	3/4	3400	9,1	2,4	207	3000	20,7	5,5	4,1	3,1	6,8

**SAE J 609 A**

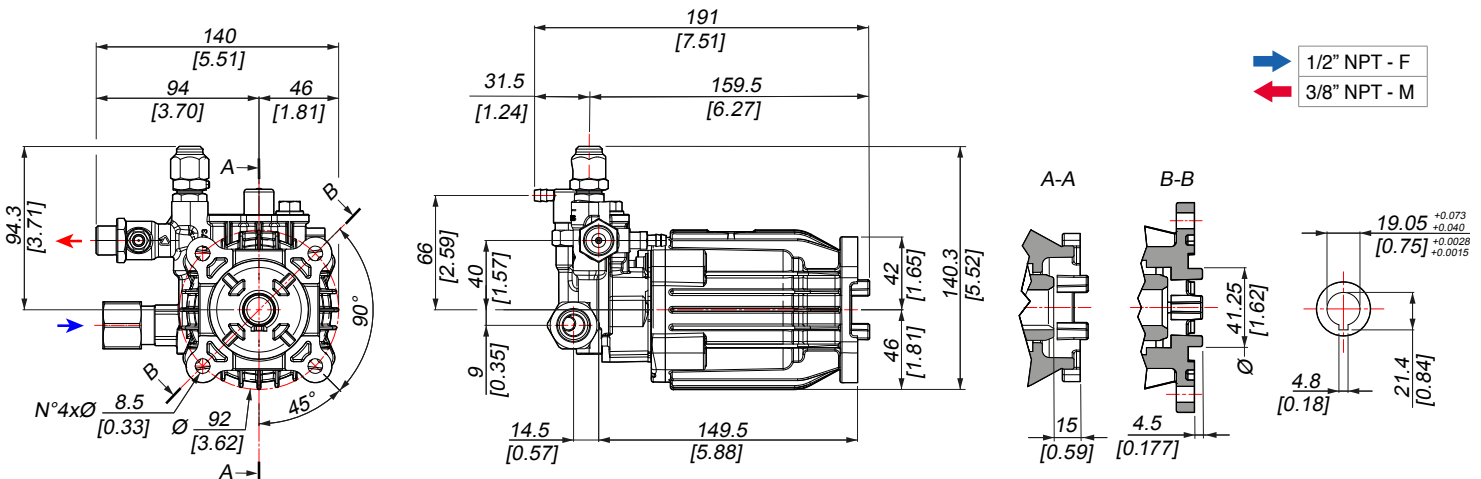

The models marked with \* are supplied with aluminum head. / I modelli contrassegnati con \* sono forniti con testata in alluminio. / Los modelos marcados con \* están disponibles con cabeza de aluminio.





## **MISTING PUMPS, LOW FLOW**

*POMPE PER EVAPORATORI A BASSA PORTATA*

*BOMBAS PARA EVAPORADORES DE BAJO CAUDAL*

---

All models are supplied with brass head.

***Other flow / pressure combinations are available on request .***

Tutti i modelli sono forniti con testata in ottone.

***Altre combinazioni di portata e pressione sono disponibili su richiesta.***

Todos los modelos están disponibles con cabeza de latón.

***Otras combinaciones de caudal y presión están disponibles bajo pedido.***

# Misting

RPM 1450 **LW**

S | Ø24 mm

RPM 1750 **LWS**



ON REQUEST › SU RICHIESTA › BAJO PEDIDO



SOLID SHAFT Ø 24 mm › ALBERO MASCHIO Ø 24 mm › EJE MACHO Ø 24 mm

Code Codice Codigo	Model Modello Modelo	Version											
			mm	rpm	l/min	US gpm	bar	psi	Mpa	HP	kW	kg	lb
6300 2400	LW 0209	S	24	1450	0,8	0,2	60	870	6,0	0,3	0,2	6,1	13,4
6300 1501	LW 0509	S	24	1450	2,0	0,5	60	870	6,0	0,3	0,2	6,1	13,4
6300 1401	LW 1009	S	24	1450	3,8	1,0	60	870	6,0	0,5	0,4	6,1	13,4
6300 1601	LW 1509	S	24	1450	5,6	1,5	60	870	6,0	0,8	0,6	6,1	13,4
6301 2700	LWS 0609	S	24	1750	3,0	0,8	60	870	6,0	0,5	0,4	6,1	13,4
6301 2500	LWS 1209	S	24	1750	4,5	1,2	60	870	6,0	0,7	0,5	6,1	13,4
6301 2600	LWS 1809	S	24	1750	7,3	1,9	60	870	6,0	1,1	0,8	6,1	13,4

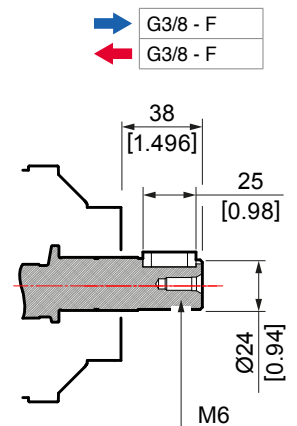
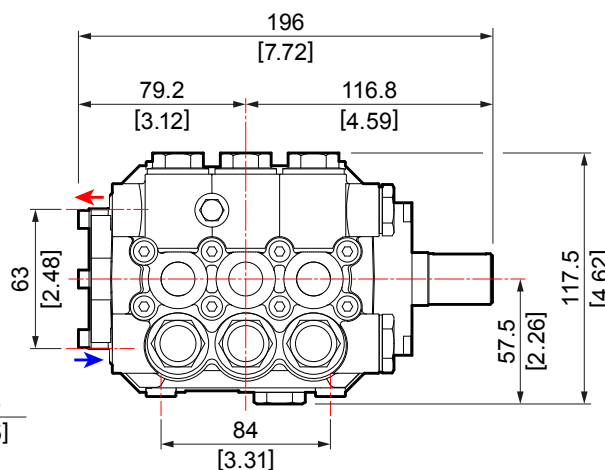
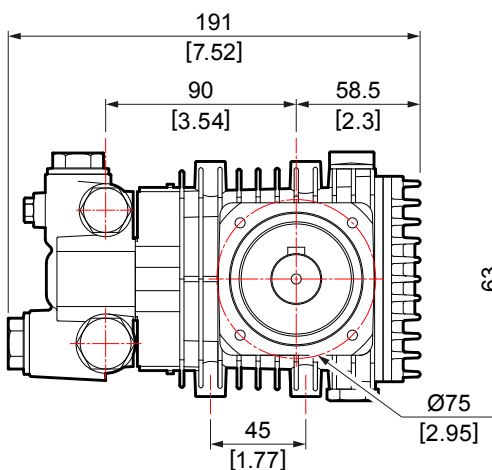



UEST › SU RICHIESTA › BAJO PEDIDO



HOLLOW SHAFT Ø 3/4" › ALBERO FEMMINA Ø 3/4" › EJE HEMBRA Ø 3/4"

Code Codice Codigo	Model Modello Modelo	Version											
			"	rpm	l/min	US gpm	bar	psi	Mpa	HP	kW	kg	lb
6300 2000	LW 0409	G	3/4	1450	1,6	0,3	60	870	6,0	0,3	0,2	6,1	13,4
6300 1500	LW 0509	G	3/4	1450	2,0	0,5	60	870	6,0	0,3	0,2	6,1	13,4
6300 1400	LW 1009	G	3/4	1450	3,8	1,0	60	870	6,0	0,5	0,4	6,1	13,4
6300 1600	LW 1509	G	3/4	1450	5,6	1,5	60	870	6,0	0,8	0,6	6,1	13,4

SAE J 609 A

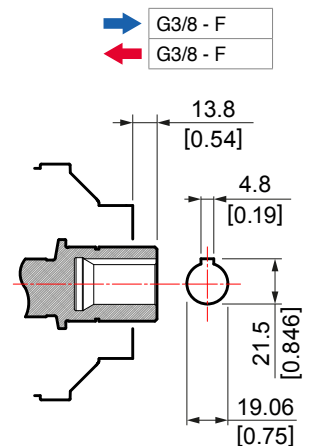
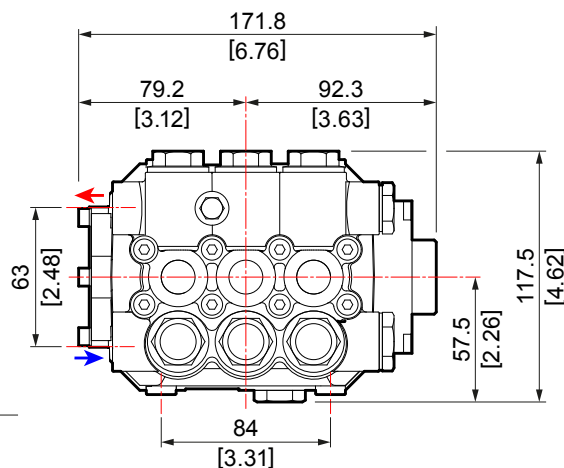
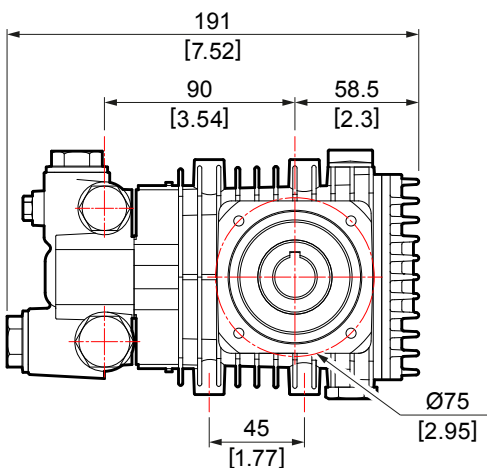



LW

E | Ø 5/8"



LWS



ON REQUEST › SU RICHIESTA › BAJO PEDIDO



HOLLOW SHAFT Ø 5/8" › ALBERO FEMMINA Ø 5/8" › EJE HEMBRA Ø 5/8"

Code Codice Codigo	Model Modello Modelo	Version	Ø	RPM	Flow		Pressure			Power		Weight	
			"	rpm	l/min	US gpm	bar	psi	Mpa	HP	kW	kg	lb
6300 2300	LW 0509	E	5/8	1450	2,0	0,5	60	870	6,0	0,3	0,2	6,1	13,4
6300 2301	LW 0522	E	5/8	1450	2,0	0,5	152	2200	15,2	1,0	0,7	6,1	13,4
6300 1402	LW 1009	E	5/8	1450	3,8	1,0	60	870	6,0	0,5	0,4	6,1	13,4
6300 1407	LW 1022	E	5/8	1450	3,8	1,0	152	2200	15,2	1,5	1,2	6,1	13,4
6300 1602	LW 1509	E	5/8	1450	5,6	1,5	60	870	6,0	0,8	0,6	6,1	13,4
6300 1607	LW 1522	E	5/8	1450	5,6	1,5	152	2200	15,2	2,0	1,4	6,1	13,4
6301 2701	LWS 0609	E	5/8	1750	3,0	0,8	60	870	6,0	0,5	0,4	6,1	13,4
6301 2501	LWS 1209	E	5/8	1750	4,5	1,2	60	870	6,0	0,7	0,5	6,1	13,4
6301 2601	LWS 1809	E	5/8	1750	7,3	1,9	60	870	6,0	1,1	0,8	6,1	13,4

NEMA 56 C

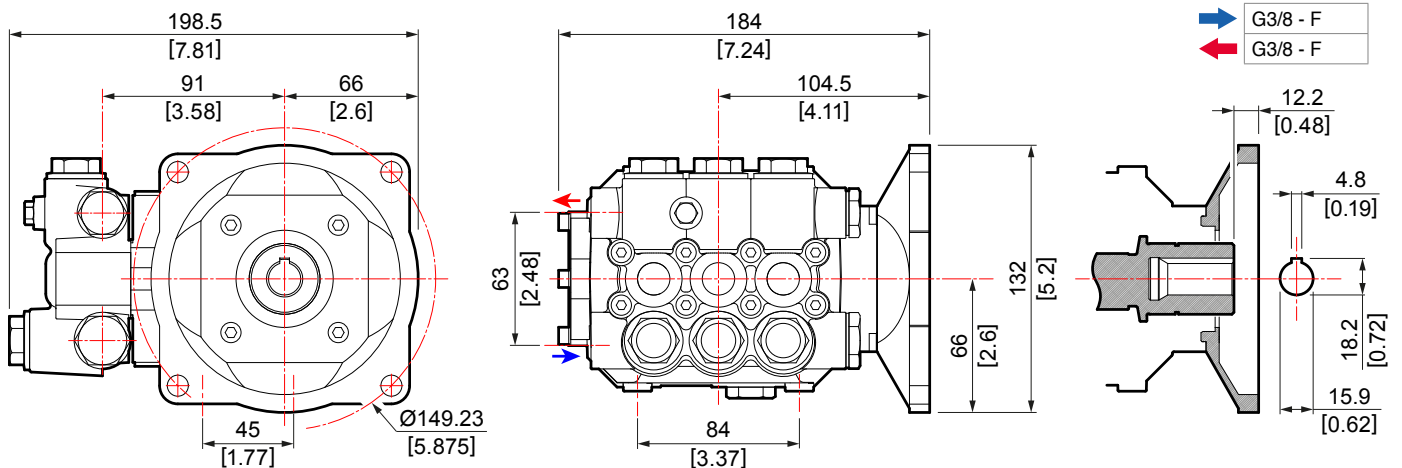



# AXS



E | Ø 5/8"



HOLLOW SHAFT Ø 5/8" › ALBERO FEMMINA Ø 5/8" › EJE HEMBRA Ø 5/8"

Code Codice Codigo	Model Modello Modelo	Version											
			Ø	rpm	l/min	US gpm	bar	psi	Mpa	HP	KW	kg	lb
▲ 6502 0009	AXS 0415	E	5/8	1750	1,7	0,5	103	1500	10,3	0,5	0,3	5,3	11,7
▲ 6502 0010	AXS 0615	E	5/8	1750	2,8	0,7	103	1500	10,3	0,7	0,5	5,3	11,7
▲ 6502 0005	AXS 0915	E	5/8	1750	3,8	1,0	103	1500	10,3	1,0	0,7	5,3	11,7
▲ 6502 0002	AXS 1010	E	5/8	1750	3,8	1,0	69	1000	6,9	0,6	0,4	5,3	11,7
▲ 6502 0007	AXS 1310	E	5/8	1750	5,0	1,3	69	1000	6,9	1,0	0,7	5,3	11,7
▲ 6502 0008	AXS 1315	E	5/8	1750	5,6	1,5	103	1500	10,3	1,5	1,0	5,3	11,7
▲ 6502 0006	AXS 2015	E	5/8	1750	7,5	2,0	103	1500	10,3	2,0	1,5	5,3	11,7

## NEMA 56 C

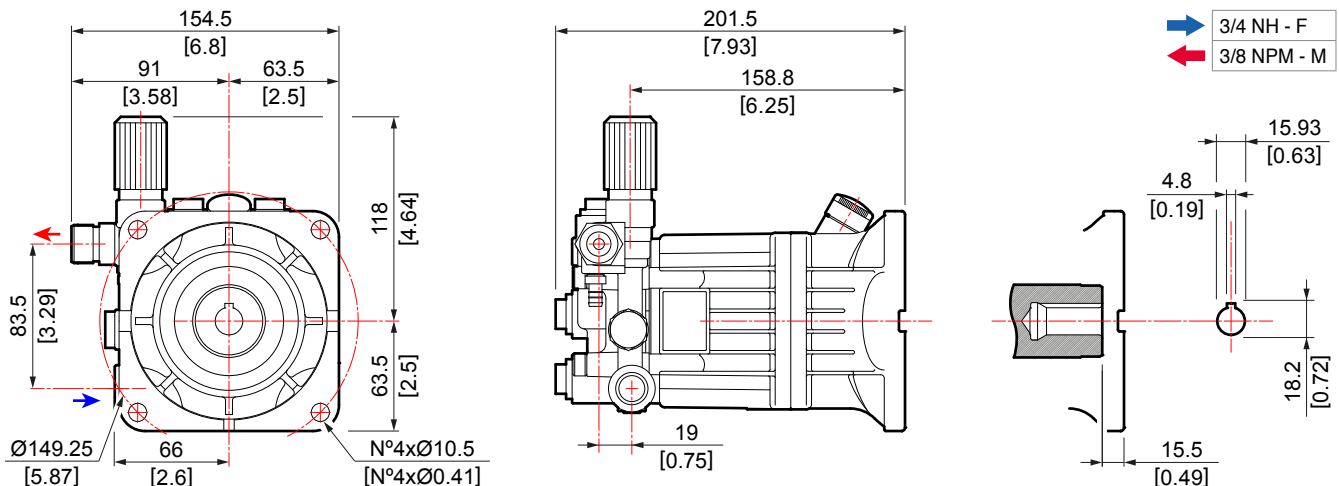

▲ Outlet connection 3/8 NPT / Connessione uscita 3/8 NPT / Conexión salida 3/8 NPT



**BXS**



**E** | Ø 5/8"



HOLLOW SHAFT Ø 5/8" › ALBERO FEMMINA Ø 5/8" › EJE HEMBRA Ø 5/8"

Code Codice Codigo	Model Modello Modelo	Version											
			"	rpm	l/min	US gpm	bar	psi	Mpa	HP	kW	kg	lb
▲ 6526 1001	BXS 0615 E		5/8	1750	2,5	0,6	103	1500	10,3	0,8	0,5	4,7	10,3

**NEMA 56 C**

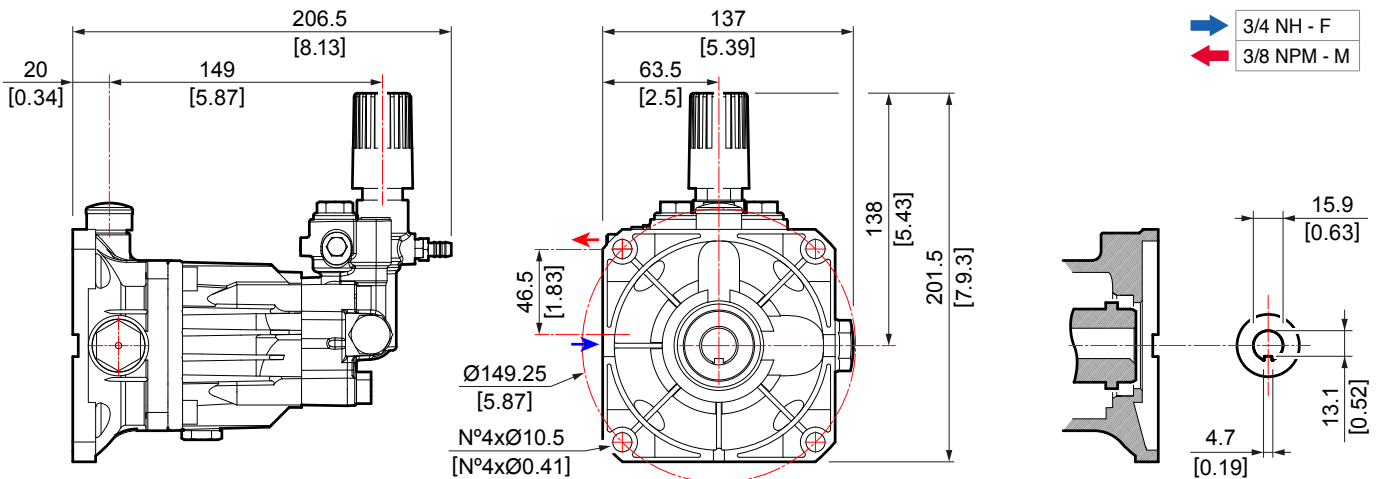

▲ Outlet connection 3/8 NPT / Connesione uscita 3/8 NPT / Coneccion salida 3/8 NPT





## **MOTOR PUMP UNITS (TRIPLEX) WITH ELECTRIC MOTOR**

*GRUPPI MOTOPOMPA (TRIPLEX)*

*CON MOTORE ELETTRICO*

*GRUPOS MOTOBOMBA (TRIPLEX)*

*CON MOTOR ELÉCTRICO*

### **BASIC VERSION**

- Motor complete with terminal board protection box.

### **TSR VERSION**

- Motor complete with electric box with toggle switch and electric cable 6 m.
- Delayed **TotalStop** device.

### **VERSIONE BASE**

- Motore dotato di scatola coprimorsettiera.

### **VERSIONE TSR**

- Motore dotato di scatola elettrica con interruttore basculante e cavo elettrico 6 m.
- Dispositivo **TotalStop** ritardato.

### **VERSIÓN BASE**

- Motor dotado de caja cubretablero de bornes.

### **VERSIÓN TSR**

- Motor dotado de caja eléctrica con interruptor-basculante y cable eléctrico 6 m.
- Dispositivo **TotalStop** retrasado.

# Motor



# MTP LWR-K 250



Code Codice Codigo	Model Modello Modelo	TSR														
			rpm	l/min	US gpm	bar	psi	Mpa	Hz	V	HP	HP	kW	MEC	kg	lb
7301 0870	MTP LWR-K 11/110		2800	11,0	2,9	110	1600	11,0	50	230 - 1	3,0	3,9	2,9	90	30,0	66,1
7301 0871	MTP LWR-K 15/150		2800	15,0	4,0	150	2175	15,0	50	230 / 400 - 3	5,5	6,7	5,0	90	30,0	66,1
7301 0872	MTP LWR-K 11/110	✓	2800	11,0	2,9	110	1600	11,0	50	230 - 1	3,0	3,9	2,9	90	32,0	70,5
7301 0873	MTP LWR-K 15/150	✓	2800	15,0	4,0	150	2175	15,0	50	400 - 3	5,5	6,7	5,0	90	32,0	70,5

## MEC 90 - TSR VERSION

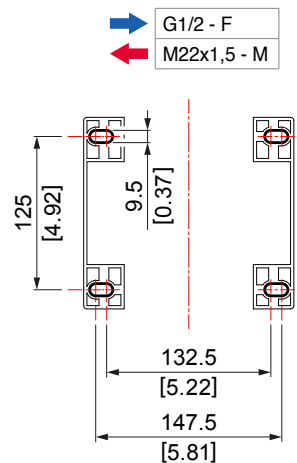
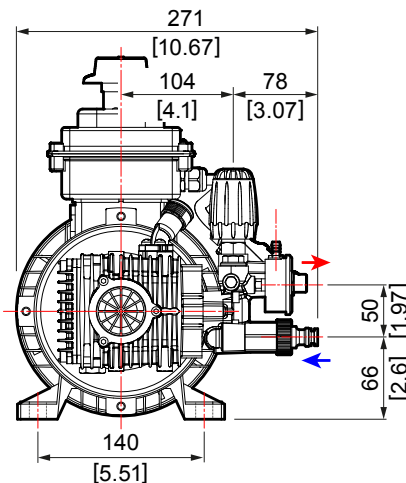
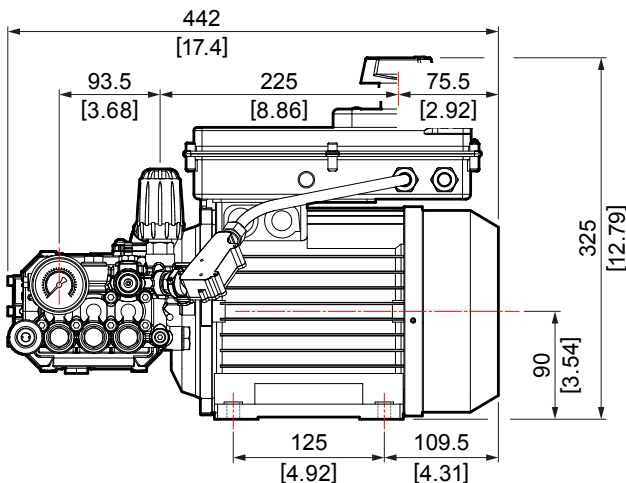

On request available 440V - 60Hz versions. / Disponibili su richiesta versioni a 440V - 60Hz. / Bajo pedido disponible en versiones 440V - 60Hz.

Contact us for NO-TSR version drawings. / I disegni per le versioni senza TSR sono disponibili su richiesta. / Contactar para los dibujos de las versiones sin TSR.



# MTP LW-K 250



Code Codice Codigo	Model Modello Modelo	TSR														
			rpm	l/min	US gpm	bar	psi	Mpa	Hz	V	HP	HP	kW	MEC	kg	lb
7301 0860	MTP LW-K 11/110		1450	11,0	2,9	110	1600	11,0	50	230 - 1	3,0	3,9	2,9	100	32,0	70,5
7301 0861	MTP LW-K 15/150		1450	15,0	4,0	150	2175	15,0	50	230 / 400 - 3	5,5	6,7	5,0	100	32,0	70,5
7301 0754	MTP LW-K 9/130	✓	1450	9,0	2,4	130	1900	13,0	50	230 - 1	3,0	3,9	2,9	100	35,0	77,1
7301 0756	MTP LW-K 10/140	✓	1450	10,0	2,6	140	2030	14,0	50	230 - 1	3,5	4,4	3,3	100	35,0	77,1
7301 0755	MTP LW-K 11/110	✓	1450	11,0	2,9	110	1600	11,0	50	230 - 1	3,0	3,9	2,9	100	35,0	77,1
7301 0783	MTP LW-K 12/100	✓	1450	12,0	3,1	100	1450	10,0	50	230 - 1	3,0	3,9	2,9	100	35,0	77,1
7301 0759	MTP LW-K 11/190	✓	1450	11,0	2,9	190	2750	19,0	50	400 - 3	5,5	6,7	5,0	100	35,0	77,1
7301 0757	MTP LW-K 13/170	✓	1450	13,0	3,4	170	2465	17,0	50	400 - 3	5,5	6,7	5,0	100	35,0	77,1
7301 0758	MTP LW-K 15/150	✓	1450	15,0	4,0	150	2175	15,0	50	400 - 3	5,5	6,7	5,0	100	35,0	77,1

## MEC 100 - TSR VERSION

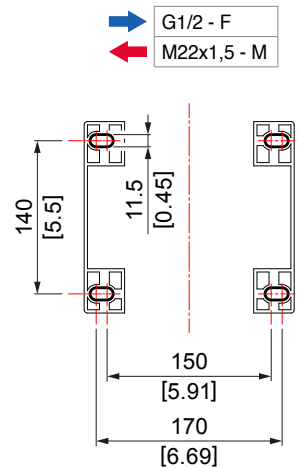
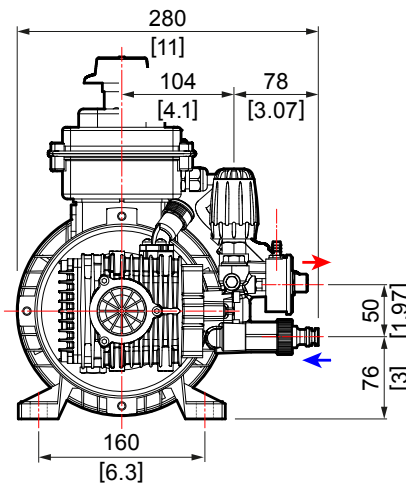
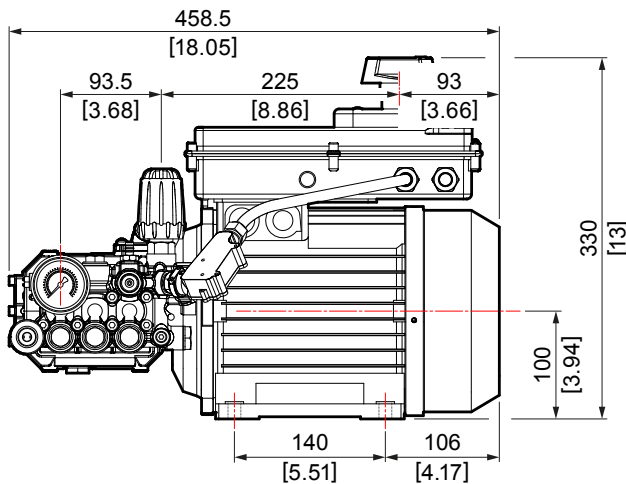

On request available 440V - 60Hz versions. / Disponibili su richiesta versioni a 440V - 60Hz. / Bajo pedido disponible en versiones 440V - 60Hz.

Contact us for NO-TSR version drawings. / I disegni per le versioni senza TSR sono disponibili su richiesta. / Contactar para los dibujos de las versiones sin TSR.



# MTP ZW-K



**TotalStop  
TSR**

Code Codice Codigo	Model Modello Modelo	TSR														
			rpm	l/min	US gpm	bar	psi	Mpa	Hz	V	HP	HP	kW	Mec	kg	lb
7301 0538	MTP ZW-K 11/120	✓	1450	11,0	2,9	120	1740	12,0	50	230 - 1	3,0	3,9	2,9	100	32,5	71,5
7301 0537	MTP ZW-K 13/180	✓	1450	13,0	3,4	180	2610	18,0	50	400 - 3	5,5	6,7	5,0	100	32,5	71,5
7301 0536	MTP ZW-K 15/160	✓	1450	15,0	4,0	160	2320	16,0	50	400 - 3	5,5	6,7	5,0	100	32,5	71,5

## MEC 100 - TSR VERSION

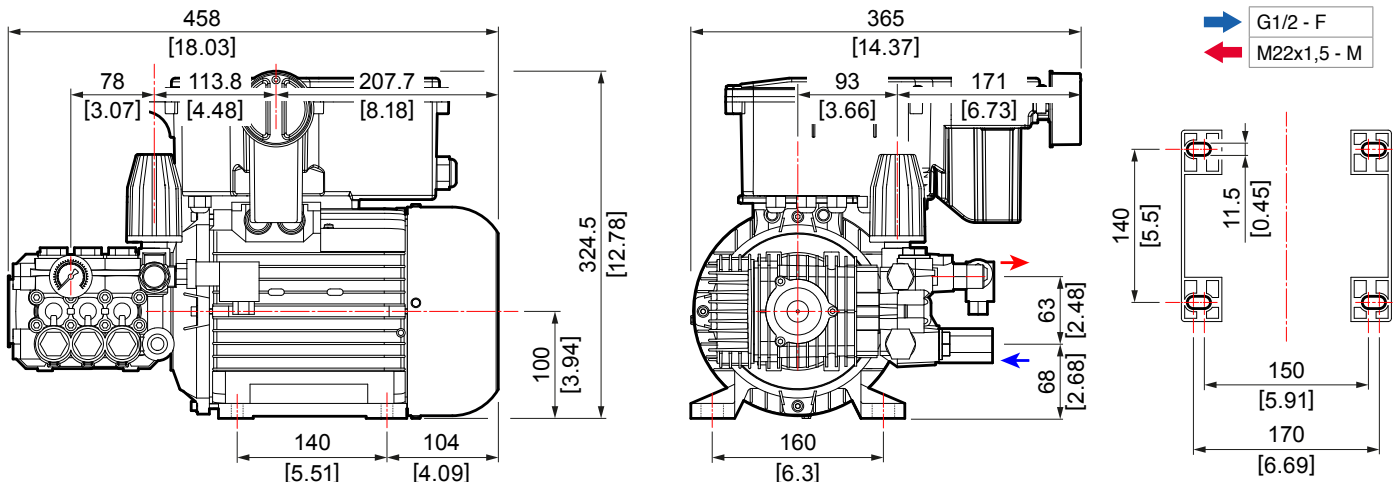

On request available 440V - 60Hz versions. / Disponibili su richiesta versioni a 440V - 60Hz. / Bajo pedido disponible en versiones 440V - 60Hz.



# MTP FW2



**TotalStop  
TSR**

Code Codice Codigo	Model Modello Modelo	TSR														
			rpm	l/min	US gpm	bar	psi	Mpa	Hz	V	HP	HP	kW	Mec	kg	lb
7301 0846	MTP FW2 13/180		1450	13,0	3,4	180	2610	18,0	50	230 / 400 - 3	5,5	6,7	5,0	100	37,0	81,6
7301 0847	MTP FW2 15/150		1450	15,0	4,0	150	2175	15,0	50	230 / 400 - 3	5,5	6,7	5,0	100	37,0	81,6
7301 0848	MTP FW2 15/200		1450	15,0	4,0	200	2900	20,0	50	230 / 400 - 3	7,5	9,3	6,9	112	42,0	92,6
7301 0849	MTP FW2 21/150		1450	21,0	5,6	150	2175	15,0	50	230 / 400 - 3	7,5	9,3	6,9	112	42,0	92,6
7301 0850	MTP FW2 13/180	✓	1450	13,0	3,4	180	2610	18,0	50	400 - 3	5,5	6,7	5,0	100	40,0	88,2
7301 0851	MTP FW2 15/150	✓	1450	15,0	4,0	150	2175	15,0	50	400 - 3	5,5	6,7	5,0	100	40,0	88,2
7301 0852	MTP FW2 15/200	✓	1450	15,0	4,0	200	2900	20,0	50	400 - 3	7,5	9,3	6,9	112	45,0	99,2
7301 0853	MTP FW2 21/150	✓	1450	21,0	5,6	150	2175	15,0	50	400 - 3	7,5	9,3	6,9	112	45,0	99,2

## MEC 112 - TSR VERSION

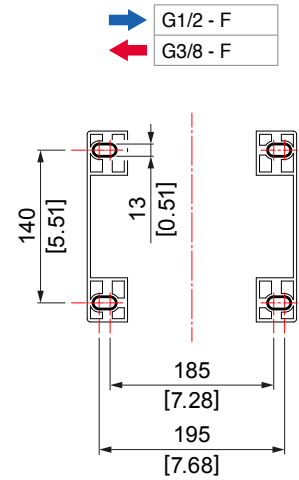
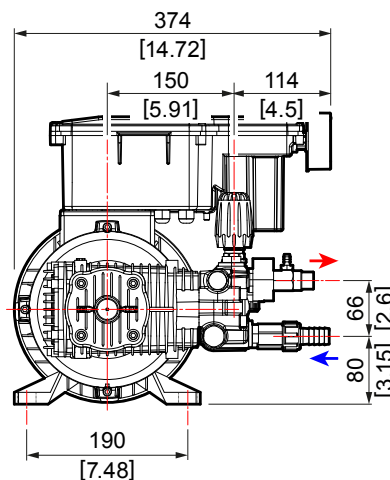
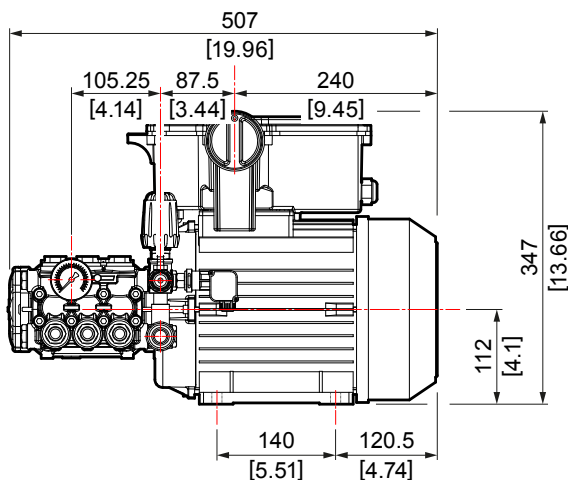

On request available 440V - 60Hz versions. / Disponibili su richiesta versioni a 440V - 60Hz. / Bajo pedido disponible en versiones 440V - 60Hz.

Contact us for NO-TSR & MEC100 version drawings. / I disegni per le versioni senza TSR & MEC100 sono disponibili su richiesta. / Contactar para los dibujos de las versiones sin TSR & MEC100.



# MTP RW



**PREMIUM**



**TotalStop  
TSR**

Code Codice Codigo	Model Modello Modelo	TSR														
			rpm	l/min	US gpm	bar	psi	Mpa	Hz	V	HP	HP	kW	Mec	kg	lb
7301 0609	MTP RW 15/170		1450	15,0	4,0	170	2465	17,0	50	230 / 400 - 3	6,0	7,4	5,5	112	46,0	101,4
7301 0653	MTP RW 15/210		1450	15,0	4,0	210	3045	21,0	50	230 / 400 - 3	7,5	9,3	6,9	112	47,0	130,6
7301 0655	MTP RW 15/230		1450	15,0	4,0	230	3335	23,0	50	230 / 400 - 3	9,0	10,0	7,5	112	48,0	105,8
7301 0854	MTP RW 16/250		1450	16,0	4,2	250	3626	25,0	50	230 / 400 - 3	10,0	11,4	8,5	132	49,0	108,0
7301 0654	MTP RW 21/160		1450	21,0	5,6	160	2320	16,0	50	230 / 400 - 3	7,5	9,3	6,9	112	47,0	103,6
7301 0656	MTP RW 21/180		1450	21,0	5,6	180	2610	18,0	50	230 / 400 - 3	9,0	10,0	7,5	112	48,0	105,8
7301 0657	MTP RW 21/200		1450	21,0	5,6	200	2900	20,0	50	230 / 400 - 3	10,0	11,4	8,5	132	49,0	108,0
7301 0531	MTP RW 15/170	✓	1450	15,0	4,0	170	2465	17,0	50	400 - 3	6,0	7,4	5,5	112	47,0	103,6
7301 0532	MTP RW 15/210	✓	1450	15,0	4,0	210	3045	21,0	50	400 - 3	7,5	9,3	6,9	112	48,0	105,8
7301 0534	MTP RW 15/230	✓	1450	15,0	4,0	230	3335	23,0	50	400 - 3	9,0	10,0	7,5	112	49,0	108,0
7301 0743	MTP RW 16/250	✓	1450	16,0	4,2	250	3626	25,0	50	400 - 3	10,0	11,4	8,5	132	50,0	110,0
7301 0533	MTP RW 21/160	✓	1450	21,0	5,6	160	2320	16,0	50	400 - 3	7,5	9,3	6,9	112	48,0	105,8
7301 0535	MTP RW 21/180	✓	1450	21,0	5,6	180	2610	18,0	50	400 - 3	9,0	10,0	7,5	112	49,0	108,0
7301 0630	MTP RW 21/200	✓	1450	21,0	5,6	200	2900	20,0	50	400 - 3	10,0	11,4	8,5	132	50,0	110,2

## MEC 132 - TSR VERSION

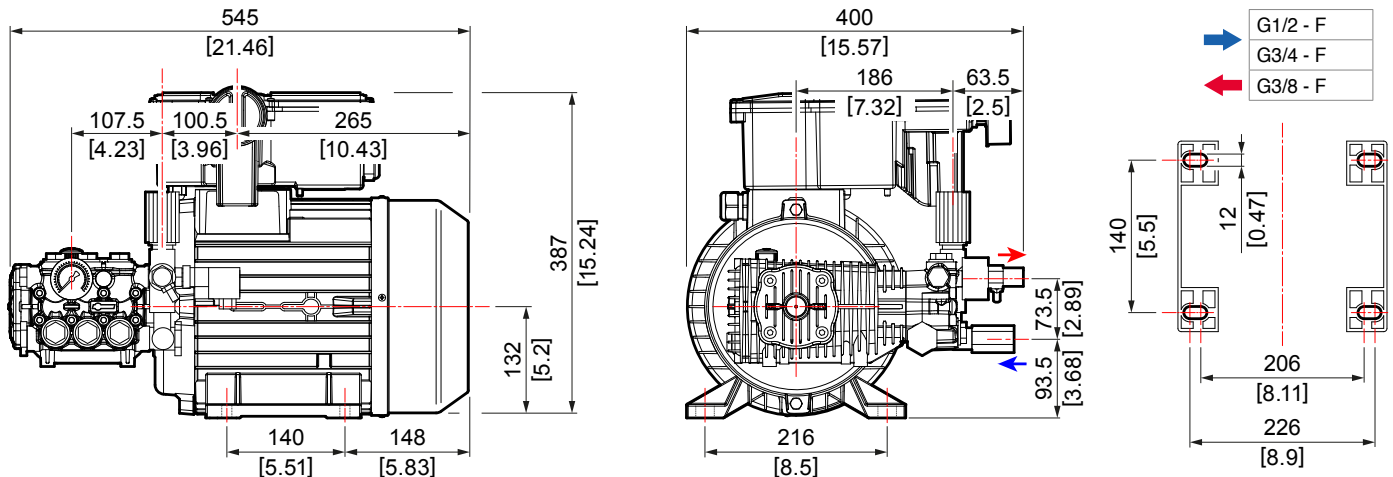

Contact us for NO-TSR & MEC112 version drawings. / I disegni per le versioni senza TSR & MEC112 sono disponibili su richiesta. / Contactar para los dibujos de las versiones sin TSR & MEC112.



# MTP TW

PREMIUM



Code Codice Codigo	Model Modello Modelo														
		rpm	l/min	US gpm	bar	psi	Mpa	Hz	V	HP	HP	kW	Mec	kg	lb
* 7301 0855	MTP TW 18/350	1450	18,0	4,7	350	5076	35,0	50	230 / 400 - 3	15,0	16,1	12,0	132	75,0	165,3
* 7301 0856	MTP TW 21/350	1450	21,0	5,6	350	5076	35,0	50	400 / 690 - 3	20,0	20,1	15,0	160 M	120,0	264,5

Motor-pump coupling with a flexible joint (integrated on motor). / Accoppiamento motore-pompa mediante giunto elastico (integrato nel motore). / Acoplamiento bomba-motor mediante junta elástica (integrada en el motor)

## MEC 160 M

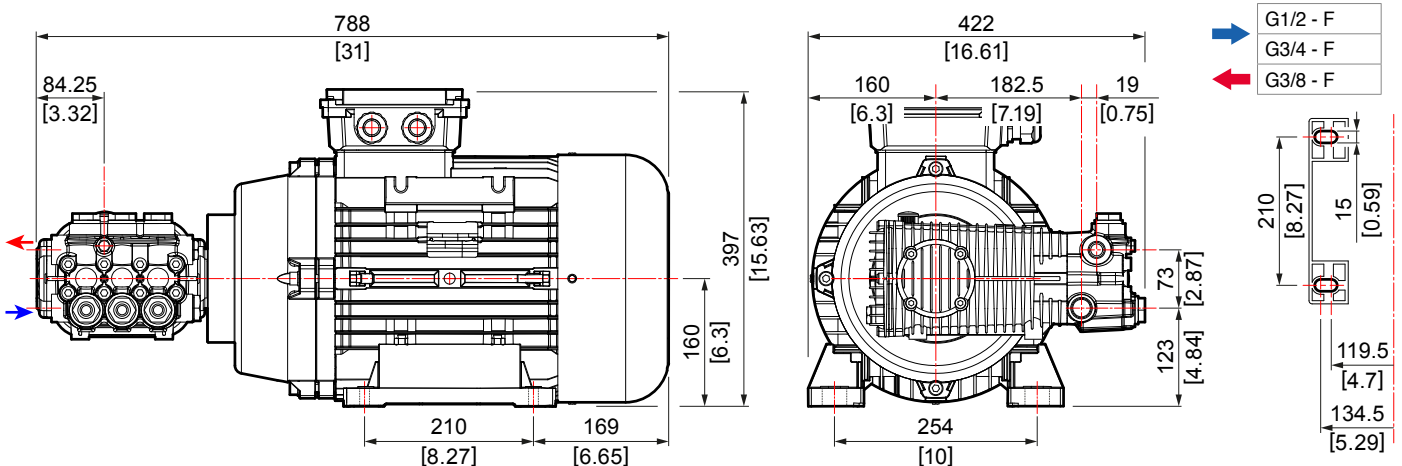

\* For connection kit see page 105 / \* Per kit di connessione vedere pagina 105 / \* Para los kit de conexión referirse a pagina 105

Contact us for MEC132 version drawings. / I disegni per le versioni MEC132 sono disponibili su richiesta. / Contactar para los dibujos de las versiones MEC132.



# MTP TW 500

PREMIUM



Code Codice Codigo	Model Modello Modelo														
		rpm	l/min	US gpm	bar	psi	Mpa	Hz	V	HP	HP	kW	Mec	kg	lb
* 7301 0857	MTP TW 15/500	1450	15	4	500	7252	50	50	400 / 690 - 3	20,0	20,1	15,0	160 M	123,0	271,1
* 7301 0858	MTP TW 21/500	1450	21	5,6	500	7252	50	50	400 / 690 - 3	30,0	30,8	23,0	160 L	128,0	282,2

Motor-pump coupling with a flexible joint (integrated on motor). / Accoppiamento motore-pompa mediante giunto elastico (integrato nel motore). / Acoplamiento bomba-motor mediante junta elástica (integrada en el motor)

## MEC 160 L

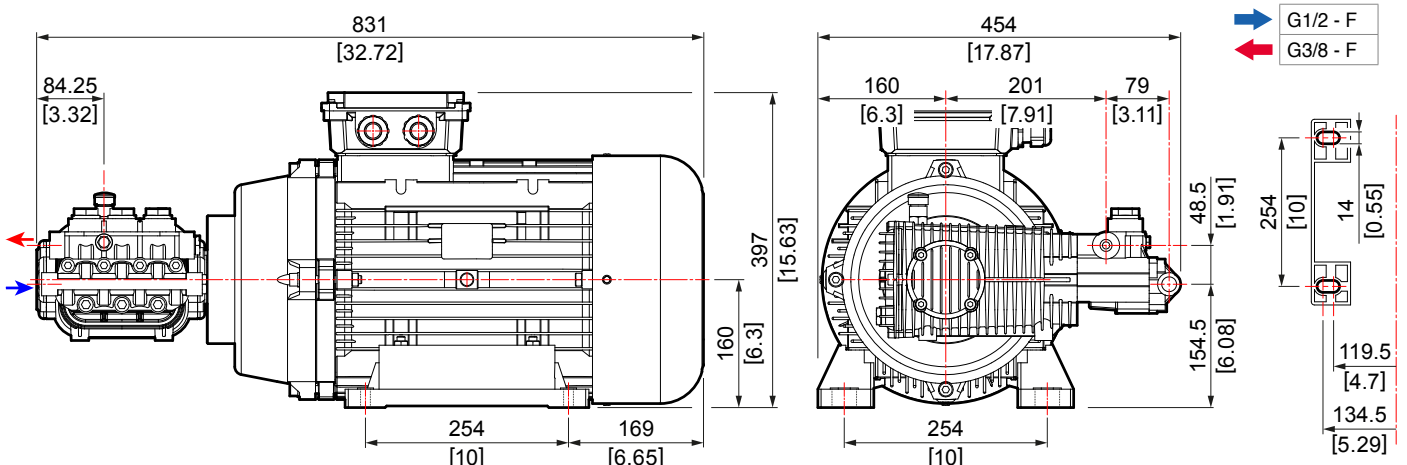

\* For connection kit see page 105 / \* Per kit di connessione vedere pagina 105 / \* Para los kit de conexión referirse a pagina 105





## **MOTOR PUMP UNITS (AXIAL) WITH ELECTRIC MOTOR**

*GRUPPI MOTOPOMPA (ASSIALI)*

*CON MOTORE ELETTRICO*

*GRUPOS MOTOBOMBA (AXIALES)*

*CON MOTOR ELÉCTRICO*

### **BASIC VERSION**

- Motor complete with terminal board protection box.

### **TSI VERSION**

- Motor complete with electric box with toggle switch and electric cable 6 m.
- Instant **TotalStop** device.

### **VERSIONE BASE**

- Motore dotato di scatola coprimorsettiera.

### **VERSIONE TSI**

- Motore dotato di scatola elettrica con interruttore basculante e cavo elettrico 6 m.
- Dispositivo **TotalStop** istantaneo.

### **VERSIÓN BASE**

- Motor dotado de caja cubretablero de bornes.

### **VERSIÓN TSI**

- Motor dotado de caja eléctrica con interruptor basculante y cable eléctrico 6 m.
- Dispositivo **TotalStop** instantaneo.

# Motor



# MTP KSR



Code Codice Codigo	Model Modello Modelo	TSI														
			rpm	l/min	US gpm	bar	psi	Mpa	Hz	V	HP	HP	kW	Mec	kg	lb
* 7301 0310	MTP KSR 8/110	✓	2800	8,0	2,1	110	1600	11,0	50	230 - 1	2,0	2,3	1,7	80	12,5	27,6
7301 0307	MTP KSR 9/130	✓	2800	9,0	2,4	130	1900	13,0	50	230 - 1	2,5	3,1	2,3	80	12,5	27,6

## MEC 80 - TSI VERSION

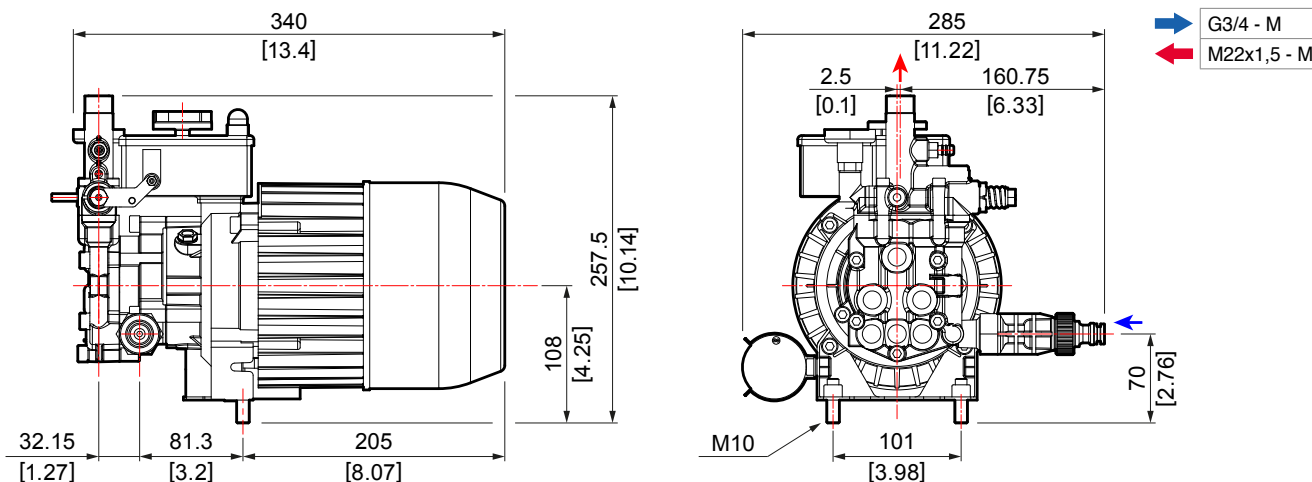

The models marked with \* are supplied with aluminum head. / I modelli contrassegnati con \* sono forniti con testata in alluminio. / Los modelos marcados con \* están disponibles con cabeza de aluminio.



# MTP AXR



Code Codice Codigo	Model Modello Modelo	TSI														
			rpm	l/min	US gpm	bar	psi	Mpa	Hz	V	HP	HP	kW	Mec	kg	lb
7301 0396	MTP AXR 8/120		2800	8,1	2,1	115	1670	11,5	50	230 - 1	2,5	3,1	2,3	90	20,0	44,1
7301 0397	MTP AXR 9/140		2800	9,1	2,4	140	2030	14,0	50	230 - 1	3,0	3,9	2,9	90	20,0	44,1
7301 0398	MTP AXR 11/120		2800	10,8	2,8	115	1680	11,5	50	230 - 1	3,0	3,9	2,9	90	20,0	44,1
7301 0399	MTP AXR 11/140		2800	10,8	2,8	140	2030	14,0	50	400 - 3	4,0	5,0	3,7	90	20,0	44,1
7301 0400	MTP AXR 11/170		2800	10,8	2,8	170	2470	17,0	50	400 - 3	5,0	5,8	4,3	90	20,0	44,1
7301 0382	MTP AXR 8/120	✓	2800	8,1	2,1	115	1670	11,5	50	230 - 1	2,5	3,1	2,3	90	20,5	45,2
7301 0383	MTP AXR 9/140	✓	2800	9,1	2,4	140	2030	14,0	50	230 - 1	3,0	3,9	2,9	90	20,5	45,2
7301 0384	MTP AXR 11/120	✓	2800	10,8	2,8	115	1680	11,5	50	230 - 1	3,0	3,9	2,9	90	20,5	45,2
7301 0385	MTP AXR 11/140	✓	2800	10,8	2,8	140	2030	14,0	50	400 - 3	4,0	5,0	3,7	90	20,5	45,2
7301 0386	MTP AXR 11/170	✓	2800	10,8	2,8	170	2470	17,0	50	400 - 3	5,0	5,8	4,3	90	20,5	45,2

## MEC 90 - TSI VERSION

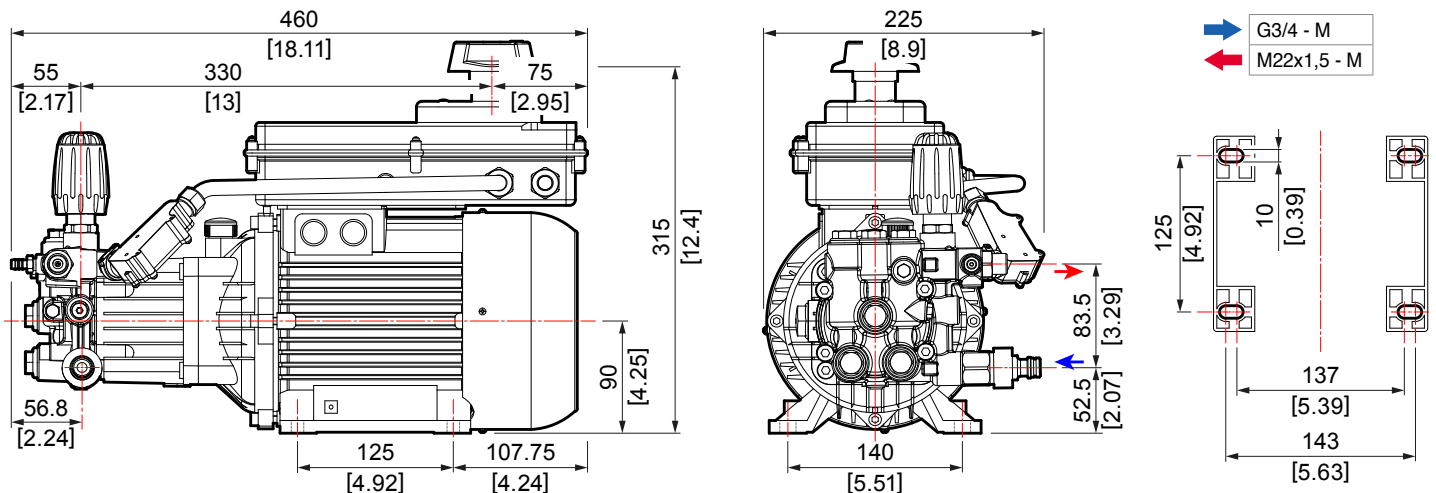

Contact us for NO-TSR version drawings. / I disegni per le versioni senza TSR sono disponibili su richiesta. / Contactar para los dibujos de las versiones sin TSR.



## **MOTOR PUMP UNITS FOR MISTING**

*GRUPPI MOTOPOMPA PER EVAPORATORI*

*A BASSA PORTATA*

*GRUPOS MOTOBOMBA PARA EVAPORADORES*

*DE BAJO CAUDAL*

### **BASIC VERSION**

- Motor complete with terminal board protection box.

### **TSI VERSION**

- Motor complete with electric box with toggle switch and electric cable 6 m.
- Instant **TotalStop** device.

### **VERSIONE BASE**

- Motore dotato di scatola coprimorsettiera.

### **VERSIONE TSI**

- Motore dotato di scatola elettrica con interruttore basculante e cavo elettrico 6 m.
- Dispositivo **TotalStop** istantaneo.

### **VERSIÓN BASE**

- Motor dotado de caja cubretablero de bornes.

### **VERSIÓN TSI**

- Motor dotado de caja eléctrica con interruptor-basculante y cable eléctrico 6 m.
- Dispositivo **TotalStop** instantaneo.

# Misting



# MTP LW MISTING



ON REQUEST › SU RICHIESTA › BAJO PEDIDO



Code Codice Codigo	Model Modello Modelo														
		rpm	l/min	US gpm	bar	psi	Mpa	Hz	V	HP	HP	kW	Mec	kg	lb
7301 0629	MTP LW 1/70	1450	0,8	0,2	69	1000	6,9	50	230 - 1	0,3	0,4	0,3	80	16,0	35,3
7301 0642	MTP LW 1/70	1450	0,8	0,2	69	1000	6,9	50	400 - 3	0,3	0,4	0,3	80	16,0	35,3
7301 0628	MTP LW 2/70	1450	2,1	0,6	69	1000	6,9	50	230 - 1	0,5	0,7	0,5	80	16,0	35,3
7301 0670	MTP LW 2/70	1450	2,1	0,6	69	1000	6,9	50	400 - 3	0,5	0,7	0,5	80	16,0	35,3
7301 0866	MTP LW 2/100	1450	2,1	0,6	100	1450	10,0	50	230 - 1	0,7	0,9	0,7	80	16,0	35,3
7301 0643	MTP LW 4/70	1450	4,2	1,1	69	1000	6,9	50	230 - 1	0,7	0,9	0,7	80	16,0	35,3
7301 0671	MTP LW 4/70	1450	4,2	1,1	69	1000	6,9	50	400 - 3	0,7	0,9	0,7	80	16,0	35,3
7301 0867	MTP LW 4/100	1450	4,2	1,1	100	1450	10,0	50	230 - 1	0,8	1,1	0,8	80	16,0	35,3
7301 0644	MTP LW 6/70	1450	5,4	1,4	69	1000	6,9	50	230 - 1	0,8	1,1	0,8	80	16,0	35,3
7301 0645	MTP LW 6/70	1450	5,4	1,4	69	1000	6,9	50	400 - 3	0,8	1,1	0,8	80	16,0	35,3
7301 0874	MTP LW 13/70	1450	13,0	3,4	69	1000	6,9	50	230 - 1	3,0	2,3	1,7	100	30,5	67,3

## MEC 80

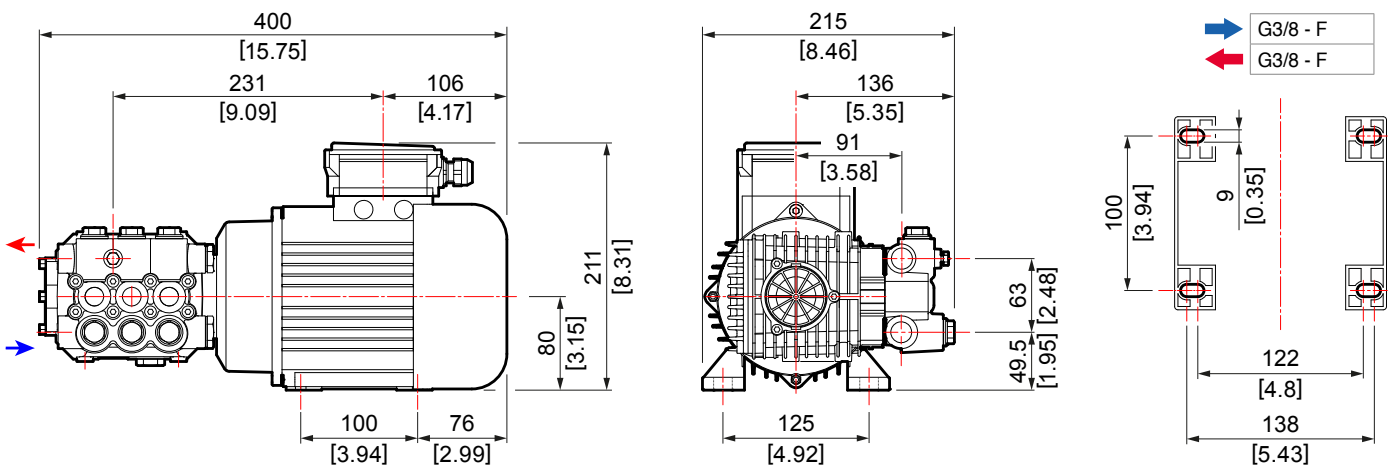



# MTP FW2 MISTING



Code Codice Codigo	Model Modello Modelo														
		rpm	l/min	US gpm	bar	psi	Mpa	Hz	V	HP	HP	kW	Mec	kg	lb
7301 0937	MTP FW2 8/70	1450	7,8	2,1	69	1000	6,9	50	230 / 400 - 3	5,5	1,3	1,0	100	37,0	81,6
7301 0876	MTP FW2 18/70	1450	18,0	4,7	69	1000	6,9	50	230 / 400 - 3	5,5	3,1	2,3	100	37,0	81,6
7301 0875	MTP FW2 21/70	1450	21,0	5,6	69	1000	6,9	50	230 / 400 - 3	5,5	3,6	2,7	100	37,0	81,6

## MEC 100

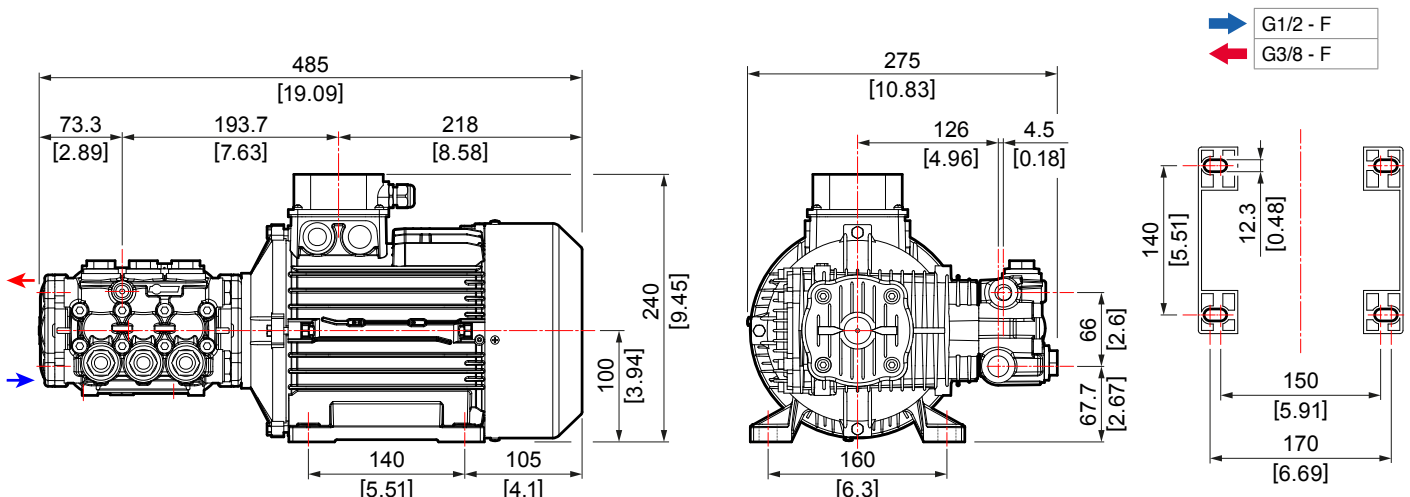



# MTP TW MISTING



Code Codice Codigo	Model Modello Modelo														
		rpm	l/min	US gpm	bar	psi	Mpa	Hz	V	HP	HP	kW	Mec	kg	lb
7301 0878	MTP TW 38/70	1450	38,0	10,0	69	1000	6,9	50	230 / 400 - 3	7,5	6,8	5,0	112	60,0	132,3
7301 0877	MTP TW 42/70	1450	42,0	11,1	69	1000	6,9	50	230 / 400 - 3	7,5	7,5	5,5	112	60,0	132,3
7301 0879	MTP TW 53/70	1450	53,0	14,0	69	1000	6,9	50	230 / 400 - 3	10,0	9,4	6,9	132	75,0	165,3

## MEC 132

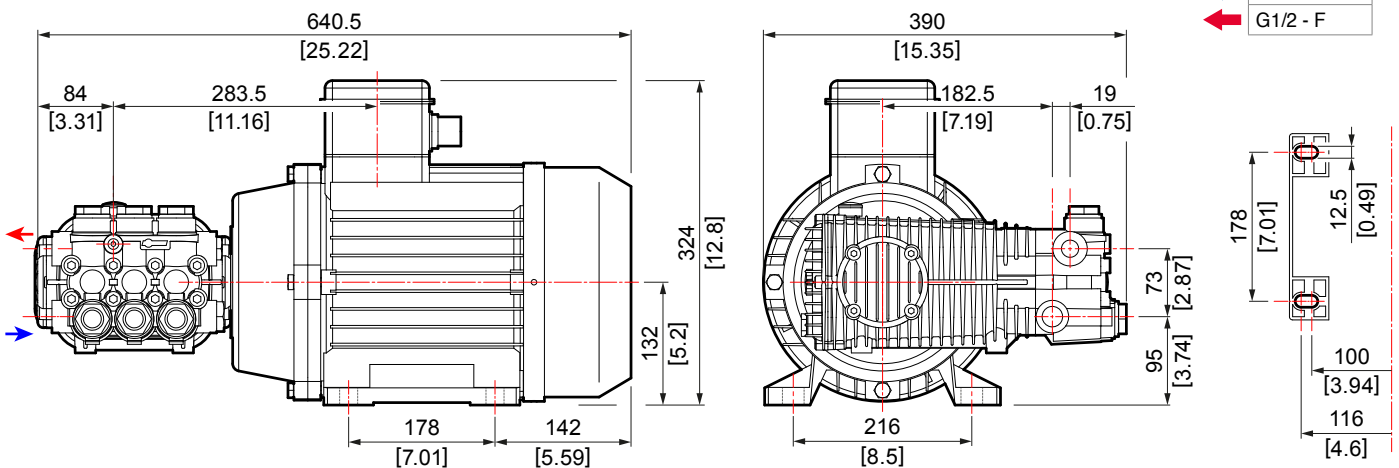



# MTP KSR MISTING



Code Codice Codigo	Model Modello Modelo														
		rpm	l/min	US gpm	bar	psi	Mpa	Hz	V	HP	HP	kW	Mec	kg	lb
7301 0508	MTP KSR 1/70	1450	1,0	0,3	69	1000	6,9	50	230 - 1	0,9	0,9	0,7	80	13,0	28,6
7301 0621	MTP KSR 2/70	1450	2,0	0,6	69	1000	6,9	50	230 - 1	0,9	1,1	0,8	80	13,0	28,6
7301 0509	MTP KSR 3/70	1450	3,0	0,8	69	1000	6,9	50	230 - 1	0,9	1,2	0,9	80	13,0	28,6

## MEC 80

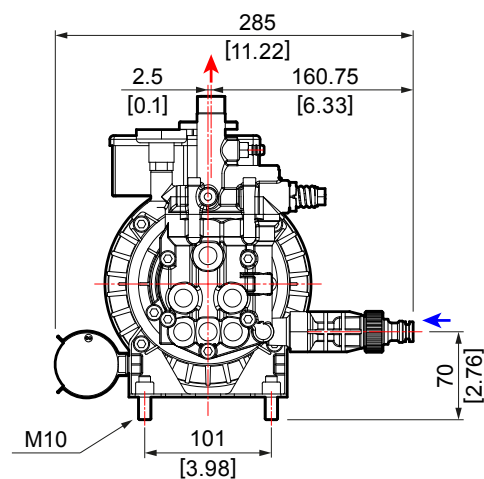
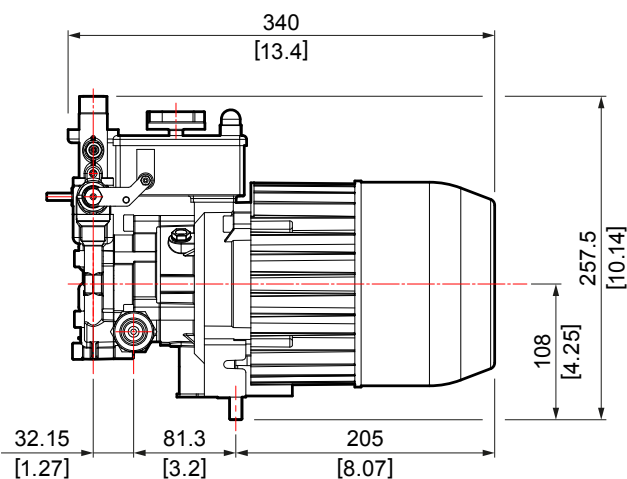





# MTP AX MISTING



Code Codice Codigo	Model Modello Modelo																
		rpm	l/min	US gpm	bar	psi	Mpa	Hz	V	HP	HP	kW	Mec	kg	lb		
7301 0449	MTP AX 1/70	1450	1,2	0,3	69	1000	6,9	50	230 - 1	1,0	0,7	0,5	80	14,0	30,9		
7301 0575	MTP AX 1/70	1450	1,2	0,3	69	1000	6,9	50	400 - 3	1,0	0,7	0,5	80	14,0	30,9		
7301 0500	MTP AX 2/70	1450	2,1	0,6	69	1000	6,9	50	230 - 1	1,0	0,9	0,7	80	14,0	30,9		
7301 0843	MTP AX 2/70	1450	2,1	0,6	69	1000	6,9	50	400 - 3	1,0	0,9	0,7	80	14,0	30,9		
7301 0864	MTP AX 2/100	1450	2,1	0,6	100	1450	10,0	50	230 - 1	1,0	1,2	0,9	80	14,0	30,9		
7301 0501	MTP AX 4/70	1450	4,2	1,1	69	1000	6,9	50	230 - 1	1,0	1,2	0,9	80	14,0	30,9		
7301 0865	MTP AX 4/100	1450	4,2	1,1	100	1450	10,0	50	230 - 1	1,0	1,3	1,0	80	14,0	30,9		
7301 0502	MTP AX 6/70	1450	5,4	1,4	69	1000	6,9	50	230 - 1	1,0	1,3	1,0	80	14,0	30,9		
7301 0576	MTP AX 6/70	1450	5,4	1,4	69	1000	6,9	50	400 - 3	1,0	1,3	1,0	80	14,0	30,9		

## MEC 80

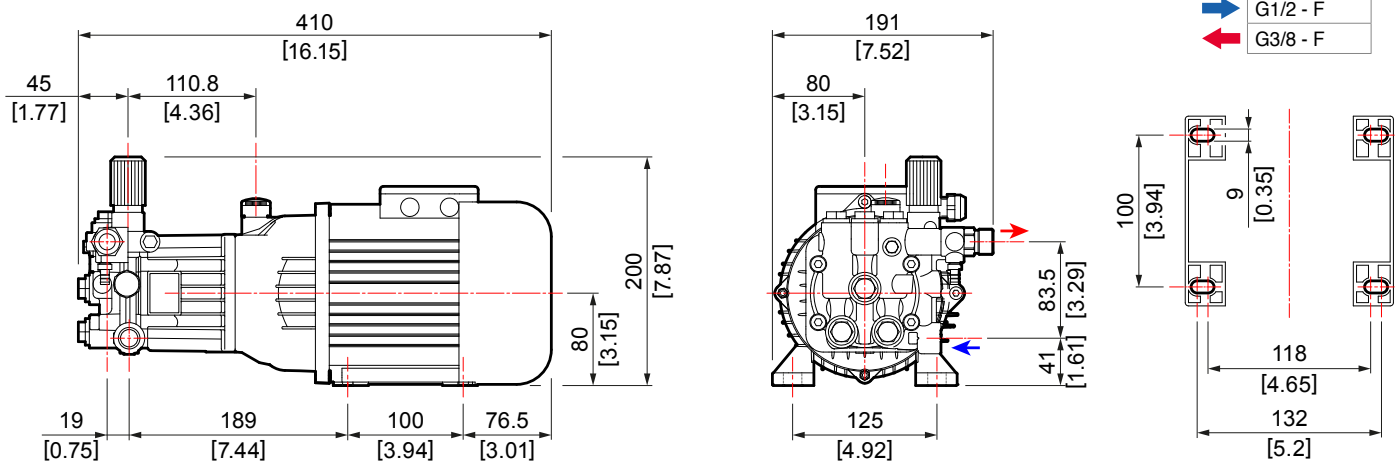



## ***MOTOR PUMP UNITS WITH HYDRAULIC MOTOR***

*GRUPPI MOTOPOMPA*

*CON MOTORE IDRAULICO*

*GRUPOS MOTOBOMBA*

*CON MOTOR HIDRÁULICO*

---

# Motor



# MTP HYDR ZW



Code Codice Codigo	Model Modello Modelo	Hydraulic Motor Motore Idraulico / Motor Hidráulico																					
										rpm	l/min	US gpm	bar	psi	Mpa	kW	CC	l/min	US gpm	bar	psi	kg	lb
7301 0800	MTP HYDR ZW 4030	1450	15,1	4,0	207	3000	20,7	6,9	20,0	29,6	7,81	162,1	2351	13,0	28,6								

## GROUP 2

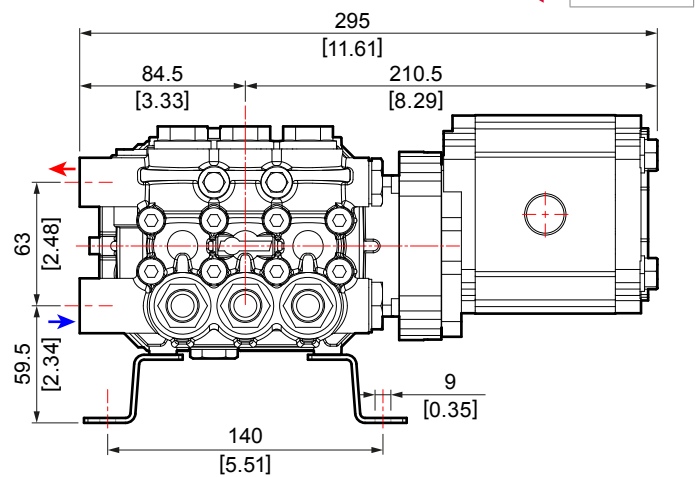
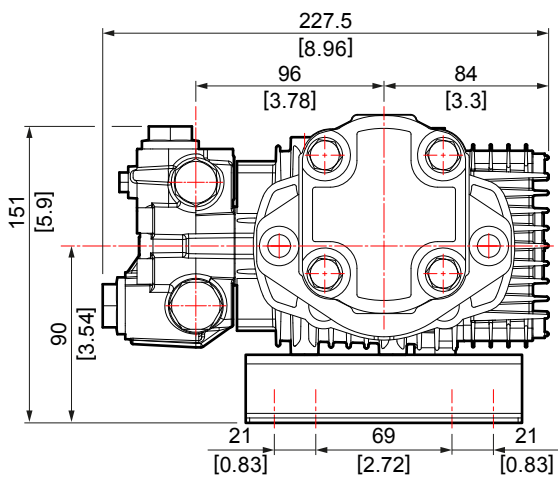



# MTP HYDR FW2



Code Codice Codigo	Model Modello Modelo	Hydraulic Motor Motore Idrraulico / Motor Hidráulico																			
										rpm	l/min	US gpm	bar	psi	Mpa	kW	CC	l/min	US gpm	bar	psi
7301 0801	MTP HYDR FW2 4022	1450	15,1	4,0	152	2200	15,2	5,0	20,0	29,6	7,81	117,5	1704	15,4	34,0						
7301 0802	MTP HYDR FW2 4030	1450	15,1	4,0	207	3000	20,7	6,9	20,0	29,6	7,81	162,1	2351	15,4	34,0						
7301 0932	MTP HYDR FW2 5016	1450	18,8	5,0	110	1600	11	3,9	20,0	29,6	7,81	91,6	1328	15,4	34,0						

## GROUP 2

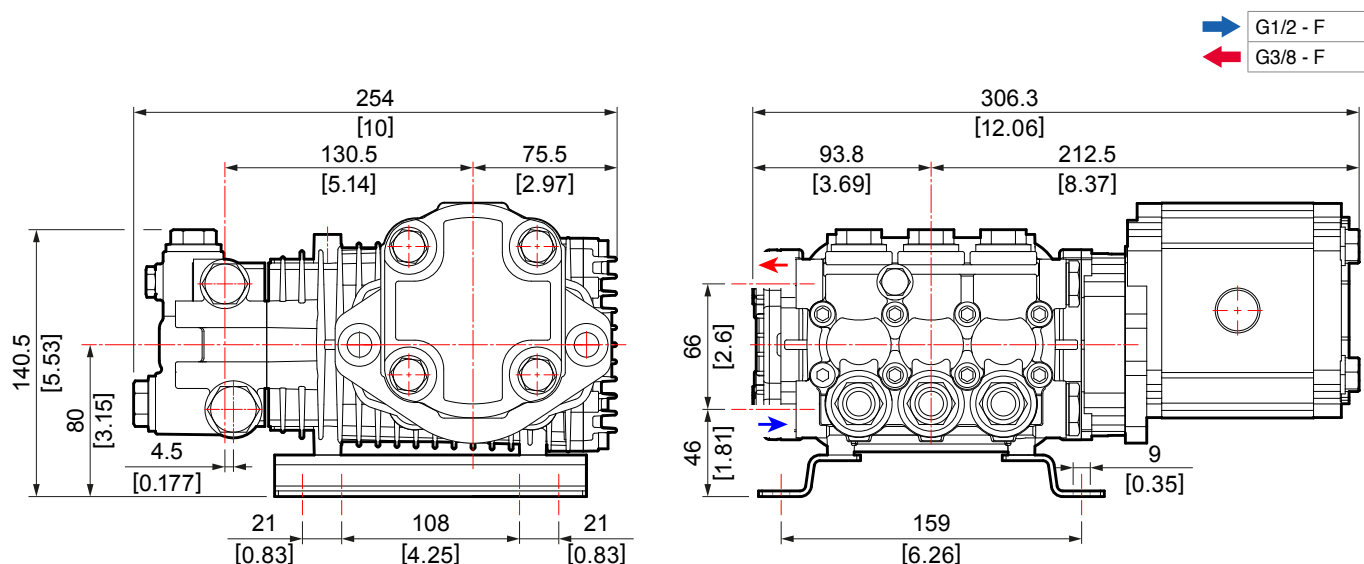



# MTP HYDR TW



Code Codice Codigo	Model Modello Modelo	Hydraulic Motor Motore Idraulico / Motor Hidráulico																					
										rpm	l/min	US gpm	bar	psi	Mpa	kW	CC	l/min	US gpm	bar	psi	kg	lb
7301 0923	MTP HYDR TW 8020	1450	32,9	8,7	138	2000	13,8	8,4	30,0	44,4	11,7	131,6	1908	25,0	55,1								

## GROUP 2

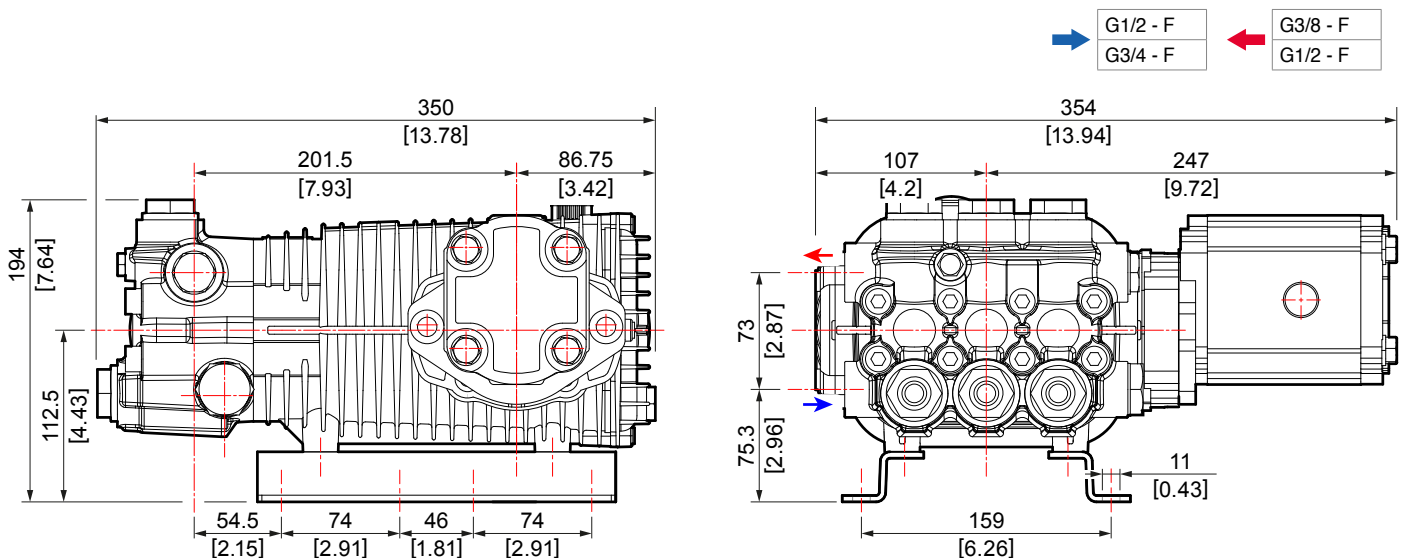



# MTP HYDR TW



Code Codice Codigo	Model Modello Modelo	Hydraulic Motor Motore Idraulico / Motor Hidráulico																					
										rpm	l/min	US gpm	bar	psi	Mpa	kW	CC	l/min	US gpm	bar	psi	kg	lb
7301 0914	MTP HYDR TW 5050	1450	20,0	5,2	345	5000	34,5	13,0	48,0	71,0	18,7	127,3	1846	30,0	66,1								
7301 0915	MTP HYDR TW 8036	1450	32,6	8,6	248	3600	24,8	15,3	48,0	71,0	18,7	149,8	2172	30,0	66,1								

## GROUP 3

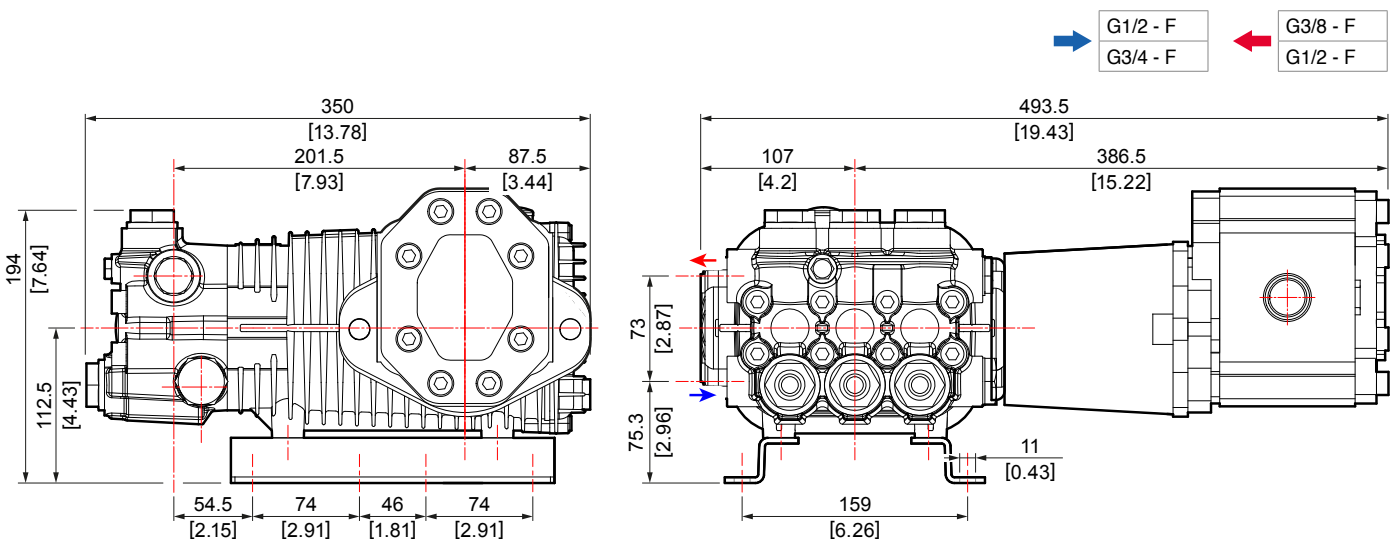



## **MOTOR PUMP UNITS WITH GAS ENGINE**

*GRUPPI MOTOPOMPA  
CON MOTORE A SCOPPIO  
GRUPOS MOTOBOMBA  
CON MOTOR DE EXPLOSIÓN*

*ON REQUEST  
SU RICHIESTA  
BAJO PEDIDO*



# Motor



# PTO

PTO

PTO

## CONSTRUCTION FEATURES

- Strong heavy duty metal frame
- Available also complete with compact closing frame (71x85x15 cm)
- Direct-fit PTO high pressure cleaners with TWN pump without gearbox kit (for 1000 rpm power take off)
- Self Priming pump
- Professional unloader valve
- Shield for cardan shaft
- Water intake filter in brass, with easy access for inspection
- Pressure Gauge

## CARATTERISTICHE COSTRUTTIVE

- Robusto telaio portante in lamiera.
- Disponibile anche completa di telaio richiudibile e di ridotte dimensioni (71x85x15 cm)
- Idropulitrici PTO per applicazione diretta con pompa TWN senza moltiplicatore (per presa di forza a 1000 giri/min)
- Pompe autoadescanti
- Valvola di regolazione pressione professionale
- Protezione Albero Cardanico
- Filtro aspirazione acqua in ottone, facilmente ispezionabile
- Manometro di pressione

## CARACTERÍSTICAS DE CONSTRUCCIÓN

- Bastidor portante robusto de chapa
- Disponible también con bastidor plegable de reducidas dimensiones (71x85x15 cm)
- Hidrolavadora PTO con bomba TWN sin multiplicador para aplicación directa (para toma de fuerza 1000 rpm)
- Bombas autocebantes
- Válvula de regulación de presión profesional.
- Protección eje Cardán
- Filtro de aspiración de agua de latón, fácil de inspeccionar
- Manómetro de presión

# PTO





# PTO

**COLD WATER HIGH PRESSURE CLEANERS FOR CONNECTION TO POWER TAKE OFF OF FARM TRACTORS** › IDROPULTRICI AD ACQUA FREDDA CON APPLICAZIONE, ALLA PRESA DI FORZA DELLE TRATTRICI AGRICOLE › HIDROLAVADORAS DE AGUA FRIA CON APLICACION A LA TOMA DE FUERZA DE LOS TRACTORES AGRICOLAS



- 1** Coupling to the tractor's 3rd point diam. 19 - 25 mm  
Attacco al terzo punto trattore diam. 19 - 25 mm  
Enganche al tercer punto del tractor Ø 19 - 25 mm
- 2** 22 mm diam. linkage pins for 3-point hitch  
Perni diametro 22 mm per attacco ai bracci del sollevatore  
Pernos de diámetro 22 mm para enganche a los brazos del elevador
- 3** Gearbox kit for 1450 rpm pumps (RW)  
Moltiplicatore per pompe a 1450 giri/min (RW)  
Multiplicador para bombas de 1450 rpm (RW)



## STANDARD ACCESSORIES › DOTAZIONE STANDARD › DOTACIÓN ESTÁNDAR

	GH 351 gun with Swivel, n. 2 o-ring Pistola GH 351 con swivel, n. 2 o-ring Pistola GH 351 con swivel, n. 2 o-ring		Bent double barrel lance, without nozzles Lancia a canna doppia angolata, senza ugelli Lanza de doble caña, sin boquillas
	Detergent nozzle 1/4" MEG connection Ugello detergente attacco 1/4" MEG Boquilla detergente conexión 1/4" MEG		Fan shape nozzle 25°, 1/4" MEG connection Ugello con getto a lama 25° attacco 1/4" MEG Boquilla con chorro plano 25° conexión 1/4" MEG
	SAE 100, 10 m rubber delivery hose kit Kit tubo gomma mandata SAE 100 - 10 m Kit tubo de manguera SAE 100 - 10 m		Water suction filter Filtro aspirazione acqua Filtro de aspiración de agua

Code Codice Codigo	Model Modello Modelo	Frame Telaio Bastidor								Reduction gear-box Moltiplic. di giri Multipli. de rev		
			rpm	l/min	US gpm	bar	psi	Mpa	HP		kW	cm
9045 0014	RW 5530 21/200	✓	550	21,0	5,5	200	2900	20,0	10,4	7,7	✓	57x82,5x70
9045 0003	TWN 6036 23/200	✓	1000	23,0	6,0	200	2900	20,0	11,4	8,4		57x82,5x70
9045 0005	TWN 8025 30/170	✓	1000	30,0	7,9	170	2465	17,0	12,8	9,4		57x82,5x70
9045 0017	RW 4022 15/150		550	15,0	4,0	150	2175	15,0	5,9	4,4	✓	57x82,5x70
9045 0016	RW 5530 21/200		550	21,0	5,5	200	2900	20,0	10,4	7,7	✓	57x82,5x70
9045 0008	TWN 6036 23/200		1000	23,0	6,0	200	2900	20,0	11,4	8,4		57x82,5x70
9045 0010	TWN 8025 30/170		1000	30,0	7,9	170	2465	17,0	12,8	9,4		57x82,5x70



# BOILER KIT

## KIT CALDAIA

## KIT CALDERA

### CONSTRUCTION FEATURES

- High pressure boiler up to 140°C
- Stainless steel body
- Gearing diesel pump with filter
- Complete with high voltage transformer
- Flame control sensor

### ON REQUEST

- Stainless steel coil

### AVAILABLE FOR SEPARATE ORDER

#### FOOT KIT

#### SUCTION / DELIVERY KIT (max 280/500 bar) made up of:

- Safety valve
- Pressure switch
- Flow switch
- Temperature sensor
- Connection pipes and unions
- Foot kit fastening kit

#### ELECTRICAL PANEL KIT (230 Vac/115 Vac/12 VDC) consisting of:

- Electrical panel
- Support plate
- Diesel fuel float sensor

### CARATTERISTICHE COSTRUTTIVE

- Caldaia ad alta pressione fino a 140°C
- Corpo in acciaio inox
- Pompa gasolio ad ingranaggi con filtro
- Completa di trasformatore alta tensione
- Sensore di controllo fiamma

### SU RICHIESTA

- Serpentina in acciaio inox

### ORDINABILI A PARTE

#### KIT PIEDI

#### KIT ASPIRAZIONE / MANDATA (max 280/500 bar) composto da:

- Valvola di sicurezza
- Pressostato
- Flussostato
- Sensore di temperatura
- Tubi e raccordi di collegamento
- Kit fissaggio a kit piedi

#### KIT QUADRO ELETTRICO (230 Vac/115 Vac/12 VDC) composto da:

- Quadro elettrico
- Piastra di supporto
- Sensore galleggiante gasolio

### CARACTERÍSTICAS DE CONSTRUCCIÓN

- Caldera de alta presión hasta 140°C
- Cuerpo en acero inoxidable
- Bomba diesel de engranaje con filtro
- Completo con transformador de alta tensión
- Sensor de control de llama

### BAJO PEDIDO

- Bobina de acero inoxidable

### PEDIBLES POR SEPARADO

#### KIT PIES

#### KIT ASPIRACIÓN / IMPULSIÓN (máximo 280/500 bar), constituido por:

- Válvula de seguridad
- Presostato
- Flujostato
- Sensor de temperatura
- Tubos y racores de conexión
- Kit fijación a kit pies

#### KIT CUADRO ELÉCTRICO (230 Vca/115 Vca/12 VCC) constituido por:

- Quadro eléctrico
- Placa de soporte
- Sensor flotante gasóleo

# Boiler

# BOILER KIT

HOT WATER MOBILE GENERATOR › GENERATORE MOBILE DI ACQUA CALDA › GENERATOR MÓVIL DE AGUA CALIENTE

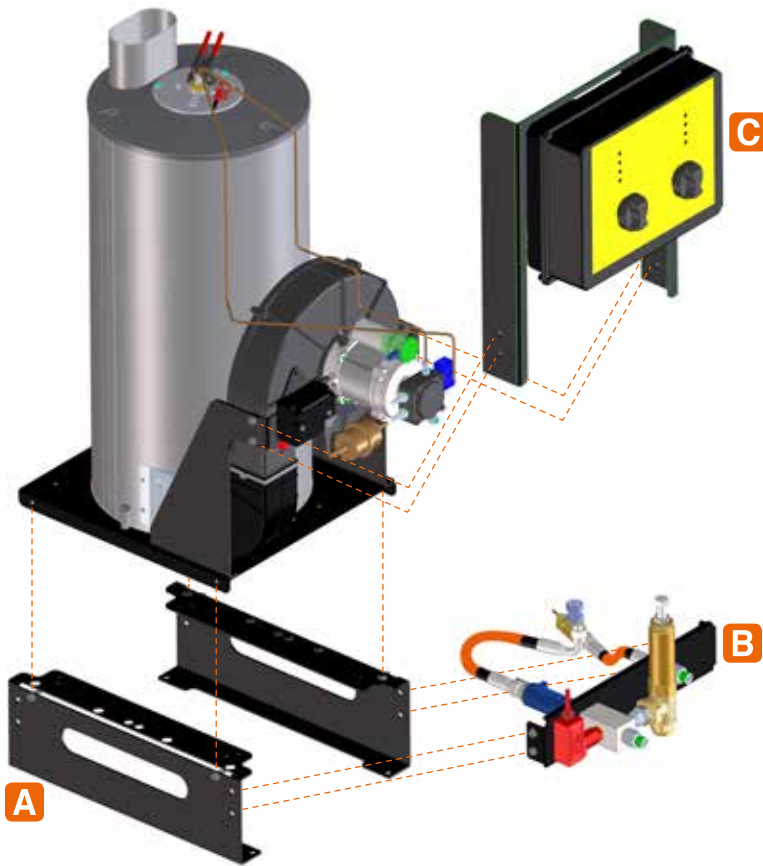

**HIGH PERFORMANCE BOILER**  
CALDAIA AD ALTE PRESTAZIONI  
CALDERA DE ALTO RENDIMIENTO

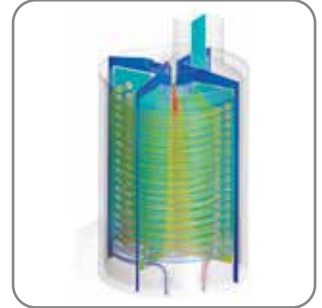

	Delta T (+/- 5°C)*		
	HOTBOX S TL 15/250	HOTBOX S TL 20/250	HOTBOX S TL 25/250-500
l/min	°C	°C	°C
11	81	87	94
13	70	76	83
15	62	69	77
18	53	60	66
21	45	52	59
23	41	48	55
25	35	43	51

Code Codice Codigo	Model Modello Modelo	Power supply Alimentazione Alimentación							
			W	A	l/min	bar	kW	kg	mm
9040 1001	HOTBOX 15/250	1-230V 50/60Hz	250	1,3	10 - 15	250	73	41	62x36,5x56
9040 1004	HOTBOX 15/250	1-115V 50/60Hz	250	2,9	10 - 15	250	73	41	62x36,5x56
9040 1009	HOTBOX 15/250	12 Vcc	250	20	10 - 15	250	73	41	62x36,5x56
9040 1002	HOTBOX 20/250	1-230V 50/60Hz	250	1,3	15 - 20	250	90	47	62x36,5x56
9040 1005	HOTBOX 20/250	1-115V 50/60Hz	250	2,9	15 - 20	250	90	47	62x36,5x56
9040 1010	HOTBOX 20/250	12 Vcc	250	20	15 - 20	250	90	47	62x36,5x56
9040 1014	HOTBOX 20/500	12 Vcc	250	20	15 - 20	500	90	47	62x36,5x56
9040 1003	HOTBOX 25/250	1-230V 50/60Hz	250	1,5	20 - 25	250	100	54	62x36,5x56
9040 1006	HOTBOX 25/250	1-115V 50/60Hz	250	3,5	20 - 25	250	100	54	62x36,5x56
9040 1011	HOTBOX 25/250	12 Vcc	250	22	20 - 25	250	100	54	62x36,5x56
9040 1008	HOTBOX 25/500	1-230V 50/60Hz	250	1,5	20 - 25	500	100	56	62x36,5x56
9040 1013	HOTBOX 25/500	1-115V 50/60Hz	250	3,5	20 - 25	500	100	56	62x36,5x56
9040 1012	HOTBOX 25/500	12 Vcc	250	22	20 - 25	500	100	56	62x36,5x56

## KIT DI COMPLETAMENTO / KIT DI COMPLETAMENTO / KIT DI COMPLETAMENTO

	Codice Code	Descrizione Description
A	2400 0200	FOOT KIT / KIT PIEDI / KIT PIES
B	5018 0167	SUCTION DELIVERY KIT (max 280 bar) / KIT ASPIRAZIONE MANDATA (max 280 bar) / KIT ASPIRACIÓN IMPULSIÓN (máximo 280 bar)
	5018 0168	SUCTION DELIVERY KIT (max 500 bar) / KIT ASPIRAZIONE MANDATA (max 500 bar) / KIT ASPIRACIÓN IMPULSIÓN (máximo 500 bar)
C	5018 0169	ELECTRICAL PANEL KIT (230 Vac) / KIT QUADRO ELETTRICO (230 Vac) / KIT CUADRO ELÉCTRICO (230 Vca)
	5018 0170	ELECTRICAL PANEL KIT (115 Vac) / KIT QUADRO ELETTRICO (115 Vac) / KIT CUADRO ELÉCTRICO (115 Vca)
	5018 0171	ELECTRICAL PANEL KIT (12 VDC) / KIT QUADRO ELETTRICO (12 VDC) / KIT CUADRO ELÉCTRICO (12 VCC)

\*The data shown are provided as a guide only. / I valori mostrati sono forniti a scopo puramente indicativo. / Los datos proporcionados son destinados exclusivamente a fines informativos.



## **ACCESSORIES**

*ACCESSORI*

*ACCESORIOS*

---

# Access

### REDUCTION GEARBOX FOR PETROL ENGINES

RIDUTTORI PER MOTORI A SCOPPIO

REDUCTORES PARA MOTORES DE EXPLOSIÓN



Model Modello Modelo	Code Codice Codigo		Engine Flange Flangia Motore Brida Motor			Ratio Rapporto Riduzione Relación reducción	For Std Pumps Per Pompe Serie Para bombas estándar
		HP		inch	rpm		
A	5005 0206	6	SAE J609 A	3/4	3400	1 : 2.31	LW (1450 RPM)
B	5005 0207	12	SAE J609 A	1	3400	1 : 2.18	FW2 - RW - TW (1450 RPM)
B	5005 0236	20	SAE J609 A	1	3400	1 : 2.18	FW2 - RW - TW (1450 RPM)
B	5005 0237	20	SAE J609 A	1 1/8	3400	1 : 2.18	FW2 - RW - TW (1450 RPM)
B	5005 0261	24	SAE J609 A*	1 1/8	3400	1 : 2.18	for HONDA GX690 motors

\* Honda approved. / Approvato da Honda. / Aprobado desde Honda.

### GEARBOX TRACTOR (P.T.O. 1" 3/8)

MOLTIPLICATORE PER TRATTORE (P.T.O. 1" 3/8)

MULTIPLICADOR PARA TRACTOR (TOMA DE FUERZA 1" 3/8)



Model Modello Modelo	Code Codice Codigo			Ratio Rapporto Riduzione Relación reducción	For Std Pumps Per Pompe Serie Para bombas estándar
		HP	rpm		
A	5005 0202	12	550	2.62 : 1	FW2 (1450 RPM)
B	5005 0238	15	550	2.62 : 1	TW - RW (1450 RPM)

### ELASTIC COUPLING KIT

KIT GIUNTI ELASTICI

KIT JUNTAS ELÁSTICAS



Model Modello Modelo	Code Codice Codigo	Electric motor / Motore elettrico / Motor eléctrico		For Std Pumps Per Pompe Serie Para bombas estándar	
			Ø shaft Ø albero Ø eje		mm
		-	mm		mm
A	1221 0047	MEC 90	24	LW	24
A	1221 0022	MEC 100 - 112	28	LW	24
A	1221 0023	MEC 100 - 112	28	FW2 - RW	24
A	1221 0026	MEC 132	32	TW	24

**APPLICATION KIT FOR CARDAN SHAFT**  
 KIT APPLICAZIONE PER ALBERO CARDANO  
 KIT APLICACIÓN PARA EJE CARDAN



**A**

Model Modello Modelo	Code Codice Codigo	For Std Pumps Per Pompe Serie Para bombas estándar
<b>A</b>	<b>5003 0050</b>	<b>TWN (1000 RPM)</b>

**PULLEY KIT**  
 KIT PULEGGIA  
 KIT POLEA



**A**

Model Modello Modelo	Code Codice Codigo	For Std Pumps Per Pompe Serie Para bombas estándar	Pulley Type Tipo Puleggia Tipo Polea
<b>A</b>	<b>5001 0072</b>	<b>LW - ZW - FW2 - RW</b>	pulley øp 160 - 2 A grooves / øp 160 - 2 GOLE A / polea øp 160 - 2 ranuras A

**APPLICATION KIT FOR HYDRAULIC MOTOR**  
 KIT APPLICAZIONE PER MOTORE IDRAULICO  
 KIT APLICACIÓN PARA MOTOR HIDRÁULICO

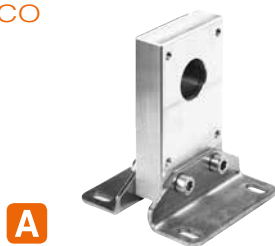

**A**



**B**

Model Modello Modelo	Code Codice Codigo	For Std Pumps Per Pompe Serie Para bombas estándar	Hydraulic Motor Type Tipo Motore Idraulico Tipo Motor Hidráulico
<b>A</b>	<b>5011 0210</b>	LWD / LWD-K / AXD / BXD / BWD / BWD-K shaft Ø 3/4 / albero Ø 3/4 / eje Ø 3/4	2S shaft M12x1,25 / albero M12x1,25 / eje M12x1,25
<b>A</b>	<b>5011 0206</b>	LWD / LWD-K / AXD / BXD / AWD / BWD / AWD-K / BWD-K shaft Ø 3/4 / albero Ø 3/4 / eje Ø 3/4	2S shaft M12x1,5 / albero M12x1,5 / eje M12x1,5
<b>B</b>	<b>5011 0256</b>	FW2 shaft Ø 24 / albero Ø 24 / eje Ø 24	shaft M12x1,5 / 2S albero M12x1,5 / eje M12x1,5
<b>B</b>	<b>5011 0258</b>	FW2 shaft Ø 24 / albero Ø 24 / eje Ø 24	shaft 5/8" / 2S albero 5/8" / eje 5/8"
<b>B</b>	<b>5011 0230</b>	RW / TW shaft Ø 24 / albero Ø 24 / eje Ø 24	shaft M12x1,5 / 2S albero M12x1,5 / eje M12x1,5
<b>B</b>	<b>5011 0284</b>	RW / TW shaft Ø 24 / albero Ø 24 / eje Ø 24	shaft 5/8" / 2S albero 5/8" / eje 5/8"
<b>B</b>	<b>5011 0294</b>	RW / TW shaft Ø 24 / albero Ø 24 / eje Ø 24	shaft 7/8" / 3S albero 7/8" / eje 7/8"
<b>B</b>	<b>5011 0301</b>	RW / TW shaft Ø 30 / albero Ø 30 / eje Ø 30	shaft 7/8" / 3S albero 7/8" / eje 7/8"

### THERMO PROTECTOR VALVE

VALVOLA TERMOSTATICA  
VÁLVULA TERMOSTÁTICA



A

Model Modello Modelo	Code Codice Codigo			Connections Attacchi Conexiones	Pump Pompa Bombas	
		°C	°F			
A	1215 0355	56	133	G 1/2	AWD - BWD - LW - ZW - FW2 - RW - TW	7
A	1215 0354	56	133	G 3/8	AXD - BXD - AWD-K - BWD-K	7
A	1215 0330	56	133	1/4 NPT	-	7

### JETTER VALVE

VALVOLA GENERATRICE DI PULSAZIONI  
VÁLVULA GENERADORA DE PULSACIONES



A

Model Modello Modelo	Code Codice Codigo	For Std Pumps Per Pompe Serie Para bombas estándar	Pump Type Tipo Pompa Tipo Bomba
A	0608 0034	LW - ZW - FW2	up to 200 bar (3000 p.s.i.) included / fino a 200 bar (3000 p.s.i.) compresi / hasta 200 bar (3000 p.s.i.) comprendidos
A	0608 0035	ZW - RW	over 200 bar (3000 p.s.i.) / oltre i 200 bar e (3000 p.s.i.) / por encima de los 200 bar (3000 p.s.i.)
A	0608 0036	RW - TW	up to 250 bar (3600 p.s.i.) included / fino a 250 bar (3600 p.s.i.) compresi / hasta 250 bar (3600 p.s.i.) comprendidos
A	0608 0037	TW	over 250 bar (3600 p.s.i.) / oltre i 250 bar (3600 p.s.i.) / por encima de los 250 bar (3600 p.s.i.)

• NB: to be applied only on **SUCTION SIDE** of pumps / • NB: da applicare solamente nel **LATO ASPIRAZIONE** della pompa. / • NB: aplicar solamente en el **LADO DE ASPIRACIÓN** de la bomba

### RELIEF VALVES

VALVOLE DI MASSIMA PRESSIONE  
VÁLVULAS DE ALIVIO DE PRESIÓN



Model Modello Modelo	Code Codice Codigo					Press. regulation Regolaz. Pressione Regulación Presión		Connections Attacchi Conexiones		Pump Pompa Bombas
		l/min	US gpm	bar	psi	fissa / fixed	regol. / adjust.	ingresso / inlet	rifiuto / by-pass.	
A	1215 0361	16,0	4,2	165	2390	X		G 1/4 M	16 mm	AWD - BWD
A	1215 0519	16,0	4,2	220	3200	X		G 1/4 M	16 mm	LW - ZW
B	1215 0104	25,0	6,5	250	3625		X	G 3/8 F	G 3/8 F	FW2 - RW
C	1215 0275	25,0	6,5	250	3625		X	2XG 3/8F	G 1/4 M	RW - TW
C	1219 2053	25,0	6,5	350	5075		X	2XG 3/8F	G 3/8 F	
D	1219 2065	100,0	26,4	500	7250		X	G 1/2 F	G 3/8 F	TW - TW 500

### RELIEF VALVES CONNECTION KIT

KIT DI CONNESSIONE  
VALVOLE DI MASSIMA PRESSIONE  
KIT DE CONEXIÓN  
VÁLVULAS DE ALIVIO DE PRESIÓN

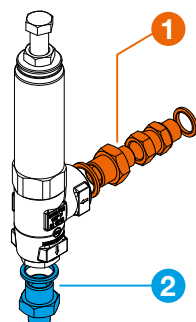

Code Codice Codigo	Valve model Modello valvola Modelo válvulas	Connections / Attacchi Conexiones		Notes Note Notas
		ingresso / inlet	uscita / outlet	
5018 0160	A	G 1/8 M	G 1/4 F	<b>1</b> included <b>2</b> not included <b>1</b> incluso <b>2</b> non incluso <b>1</b> incluido <b>2</b> no incluido
5018 0161	A	G 3/8 M	G 1/4 F	<b>1</b> included <b>2</b> not included <b>1</b> incluso <b>2</b> non incluso <b>1</b> incluido <b>2</b> no incluido
5018 0162	B - C	G 1/4 M	G 3/8 M	<b>1</b> + <b>2</b> included <b>1</b> + <b>2</b> inclusi <b>1</b> + <b>2</b> incluidos
5018 0163	B - C	G 3/8 M	G 3/8 M	
5018 0164	D	G 3/8 M	G 1/2 M	
5018 0165	D	G 1/2 M	G 1/2 M	

• Relief valve exclusively for use on high-pressure washing equipment, maximum category I, as per the classification set out in Directive 97/23/CE (PED). / Valvola di massima pressione destinata ad essere impiegata esclusivamente su attrezzature per il lavaggio ad alta pressione, al massimo di categoria I secondo la classificazione della direttiva 97/23/CE (PED). / Válvulas de alivio de presión para utilizarla exclusivamente en equipos para el lavado a alta presión, al máximo de categoría I según la clasificación de la directiva 97/23/CE (Equipos a presión (PED)).

**CONNECTION KIT**  
KIT DI CONNESSIONE  
KIT DE CONEXIÓN

Code Codice Codigo	Valve type Tipo di valvola Tipo de válvula	For Standard Pumps Per Pompe di Serie Para bombas estándar	Notes Note Notas	Filter Filtro Filtro
5018 0052	-	BWD (3400 RPM) LW (1450 RPM) ZW - FW2 - RW (1450 RPM)	unloader valve (A) and couplings (B + C) <b>not included</b> valvola di regolazione (A) e raccordi (B + C) <b>non inclusi</b> válvula de regulación (A) y racores (B + C) <b>no incluidos</b>	filter (D) filtro (D) filtro (D)
5018 0136	VR 54	AWD - BWD (3400 RPM) LW (1450 RPM) with pressure up to 140 bar con pressione fino a 140 bar con presión hasta 140 bar	couplings (B + C) <b>integrated on valve</b> raccordi (B + C) <b>integrati sulla valvola</b> racores (B + C) <b>integrados en la válvula</b>	"Y" filter (E) filtro "Y" (E) filtro "Y" (E)
5018 0137	VR 54	AWD - BWD (3400 RPM) LW (1450 RPM) with pressure up to 180 bar con pressione fino a 180 bar con presión hasta 180 bar	couplings (B + C) <b>integrated on valve</b> raccordi (B + C) <b>integrati sulla valvola</b> racores (B + C) <b>integrados en la válvula</b>	"Y" filter (E) filtro "Y" (E) filtro "Y" (E)
5018 0166	VRT 3	FW2 - ZW - RW (1450 RPM) with flow rate up to 30 l/min - max 150 bar con portata fino a 30 l/min - max 150 bar con caudal hasta 30 l/min - max 150 bar	<b>complete with valve (A) and couplings (B + C)</b> <b>completa di valvola (A) e raccordi (B + C)</b> <b>completa de válvula (A) y racores (B + C)</b>	"Y" filter (E) filtro "Y" (E) filtro "Y" (E)
5018 0138	VRT 3	FW2 - ZW - RW (1450 RPM) TW (1450 RPM) with flow rate up to 23 l/min - max 280 bar con portata fino a 23 l/min - max 280 bar con caudal hasta 23 l/min - max 280 bar	<b>complete with valve (A) and couplings (B + C)</b> <b>completa di valvola (A) e raccordi (B + C)</b> <b>completa de válvula (A) y racores (B + C)</b>	"Y" filter (E) filtro "Y" (E) filtro "Y" (E)
5018 0070	VRT 100	TW (1450 RPM) with pressure up to 300 bar con pressione fino a 300 bar con presión hasta 300 bar	<b>complete with valve (A) and couplings (B + C)</b> <b>completa di valvola (A) e raccordi (B + C)</b> <b>completa de válvula (A) y racores (B + C)</b>	"Y" filter (E) filtro "Y" (E) filtro "Y" (E)
5018 0135	BP 100/550	TW - TW 500 (1450 RPM) with pressure up to 500 bar con pressione fino a 500 bar con presión hasta 500 bar	<b>complete with valve (A) and couplings (B + C)</b> <b>completa di valvola (A) e raccordi (B + C)</b> <b>completa de válvula (A) y racores (B + C)</b>	"Y" filter (E) filtro "Y" (E) filtro "Y" (E)

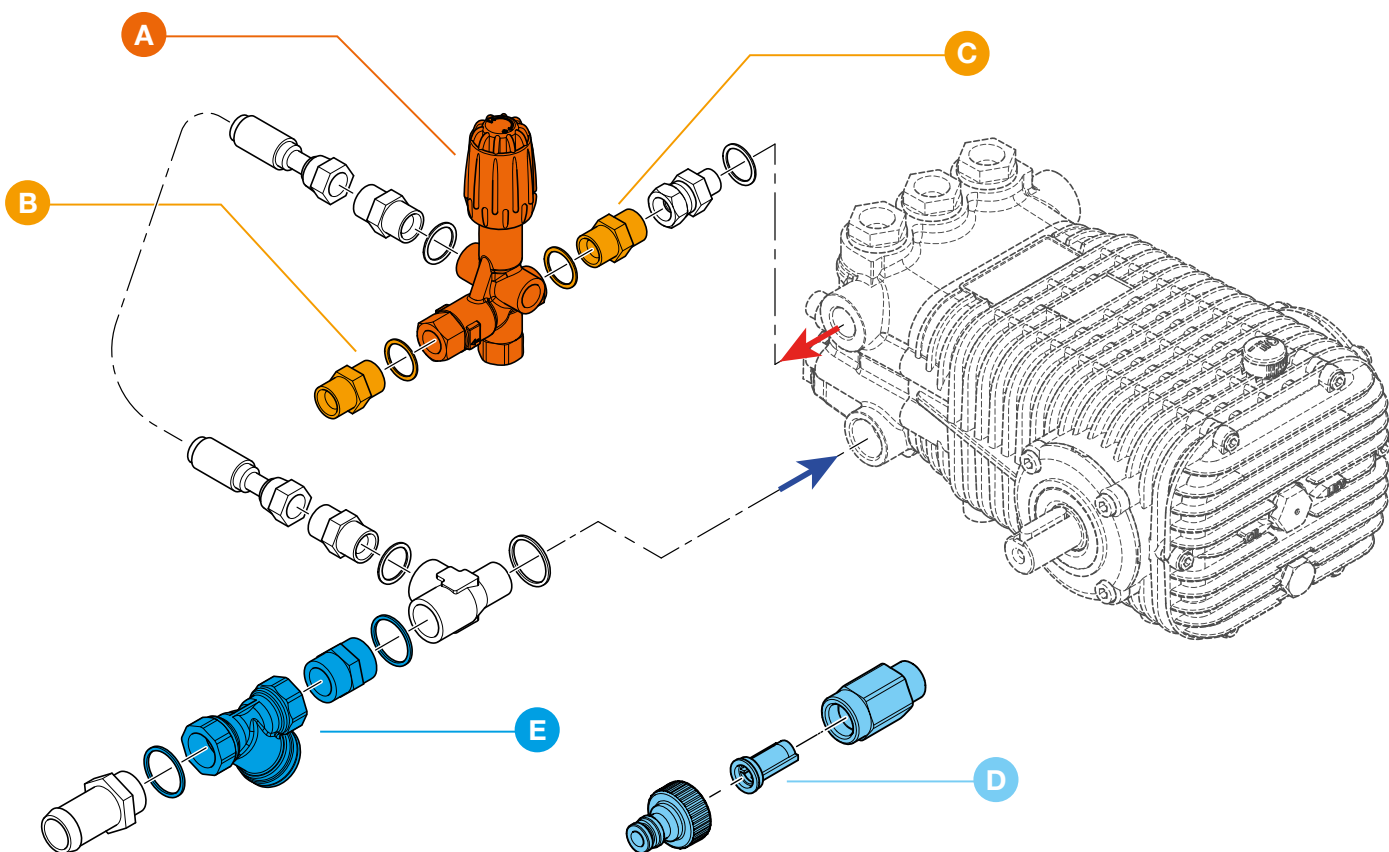



## UNLOADER VALVES

VALVOLE DI REGOLAZIONE

VÁLVULAS DE REGULACIÓN



VRF 2



VR 54



VRC 25



VB 10/2



VRT 3

VRT 3  
multifunction

Code Codice Codigo	Model Modello Modelo					Connections Attacchi Conexiones			Adj. Det. Suction Asp. Det. Reg. Aspir. Det.		Std Pumps Pompe Serie Bombas Estándar	Knob kit Kit manopola Kit de perilla
		l/min	US gpm	bar	psi	inlet ingresso entrada	outlet uscita salida	by-pass rifiuto by-pass				
1215 0220	VRF 2	30	8	220	3200	G 1/2 F	M22 x 1,5 M	-	reg	90	LW - ZW	✓
1215 0233	VRF 2	30	8	220	3200	G 1/2 F	3/8 NPT M	-	reg	90	LW - ZW	✓
1215 0382	VRF 2	30	8	220	3200	G 1/2 F	G 3/8 M	-	X	90	LW - ZW	✓
1215 0290	VRF 2	30	8	220	3200	G 1/2 F	M22 x 1,5 M	-	X	90	FW2	✓
1215 0288	VRF 2	30	8	220	3200	G 1/2 F	3/8 NPT M	-	X	90	FW2	✓
1215 0253	VRF 2	30	8	280	4050	G 1/2 F	3/8 NPT M	-	reg	90	ZW - FW2	✓
1215 0579	VRF 2	30	8	280	4050	G 1/2 F	G 3/8 M	-	X	90	ZW - FW2	✓
1215 0580	VRF 2	30	8	280	4050	G 1/2 F	M22 x 1,5 M	-	X	90	ZW - FW2	✓
1215 0565	VRF 2	30	8	280	4050	G 1/2 F	G 3/8 F	-	NO	90	ZW - FW2	✓
1215 0575	VRF 2	30	8	280	4050	G 1/2 F	3/8 NPT M	-	reg	90	RW	✓
1215 0582	VRF 2	30	8	280	4050	G 1/2 F	G 3/8 M	-	X	90	RW	✓
1215 0581	VRF 2	30	8	280	4050	G 1/2 F	M22 x 1,5 M	-	X	90	RW	✓
1215 0564	VRF 2	30	8	280	4050	G 1/2 F	G 3/8 F	-	NO	90	RW	✓
1215 0238 A	VR 54	30	8	140	2050	G 3/8 M	G 3/8 M	G 3/8 F	NO	90	AWD - BWD - LW	✓
1215 0529 A	VR 54	30	8	180	2600	G 3/8 M	G 3/8 M	G 3/8 F	NO	90	AWD - BWD - LW	✓
1215 0535	VRC 25 *	30	8	220	3200	G 3/8 F	G 3/8 M	2x G 3/8 F	X	90	AW - BW - LW ZW - FW2 - RW	✓
1215 0540	VRC 25 *	30	8	220	3200	G 3/8 F	G 3/8 M	2x G 3/8 F	NO	90	AW - BW - LW ZW - FW2 - RW	✓

\* Compensated (or soft) unloader valve. / Valvole a compensazione di pressione. / Válvulas Compensadas.

X Ejector by suction, possibility to control the quantity of detergent suctioned up. / Eiettore per aspirazione, possibilità di regolare la quantità di detergente aspirata. / Ejector para aspiración, se puede regular la cantidad de detergente aspirada.

reg Adjustable detergent suction. / Aspirazione detergente regolabile. / Aspiración detergente regulable.

✓ Built-in knob kit. / Kit manopola integrata. / Kit de perilla integrada.

**UNLOADER VALVES**

VALVOLE DI REGOLAZIONE  
VÁLVULAS DE REGULACIÓN



VHP 39



VRT 100



BP 100/550



BP 80/400  
BP 80/640



ZERO 280



ZERO 400  
ZERO 600

Code Codice Codigo	Model Modello Modelo					Connections Attacchi Conexiones			Adj. Det. Suction Asp. Det. Reg. Aspir. Det.		Std Pumps Pompe Serie Bombas Estándar	Knob kit Kit manopola Kit de perilla
		l/min	US gpm	bar	psi	inlet ingresso entrada	outlet uscita salida	by-pass rifiuto by-pass				
1215 0417	VB 10/2 **	30	8	220	3200	G 3/8 F	G 3/8 M	2 x G 3/8 F	NO	90	ZW - FW2 - RW	✓
1215 0351	VB 10/2 **	30	8	220	3200	G 3/8 F	G 3/8 M	2 x G 3/8 F	X	90	ZW - FW2 - RW	✓
1215 0668	VRT3	40	10,5	160	2321	G 3/8 F	G 3/8 F	2 x G 3/8 F	NO	90	AW - BW - LW ZW - FW2 - RW	✓
1215 0541	VRT3	30	8	220	3200	G 3/8 F	G 3/8 M	2 x G 3/8 F	NO	90	AW - BW - LW ZW - FW2 - RW	✓
1215 0454	VRT3	30	8	280	4050	G 3/8 F	G 3/8 F	2 x G 3/8 F	NO	90	AW - BW - LW ZW - FW2 - RW	✓
1215 0340 A	VRT 3 multifunction	30	8	280	4050	3/8 NPT F	3/8 NPT M	3/8 NPT F	reg	56/90	AW - BW - LW ZW - FW2 - RW	✓
1215 0546	VHP 39	40	10,5	350	5050	G 3/8 F	M22 x 1,5 M	2 x G 3/8 F	reg	90	FW2 - RW - TW	✓
1215 0563	VHP 39	40	10,5	350	5050	G 3/8 F	G 3/8 F	2 x G 3/8 F	NO	90	FW2 - RW - TW	✓
1215 0577	VRT 100 □	100	26,5	170	2465	G 1/2 F	G 1/2 F	G 1/2 F	NO	90	TW	5011 0303
1215 0569	VRT 100	100	26,5	320	4641	G 1/2 F	G 1/2 F	G 1/2 F	NO	90	TW	5011 0304
1215 0632	BP 100/550	100	21	550	7250	G 1/2 F	G 1/2 F	G 1/2 F	NO	90	TW 500	1817 0102
1215 0600	BP 80/400 **	80	21	400	5800	G 1/2 F	G 1/2 F	G 1/2 F	NO	90	TW 500	1817 0101
1215 0599	BP 80/640 **	80	21	640	9280	G 1/2 F	G 1/2 F	G 1/2 F	NO	90	TW 500	1817 0101
1215 0524	ZERO 280 ***	40	10,5	280	4050	G 3/8 F	G 3/8 F	2 x G 3/8 F	NO	90	FW2 - RW - TW	✓
1215 0531	ZERO 400 ***	60	16	400	5800	G 1/2 F	G 1/2 F	G 1/2 F	NO	90	TW 500	3606 0026
1215 0532	ZERO 600 ***	60	16	600	8700	G 1/2 F	G 1/2 F	G 1/2 F	NO	90	TW 500	3606 0026

\* Compensated (or soft) unloader valve. / Valvole a compensazione di pressione. / Válvulas Compensadas.

\*\* Discharge control unloader valve. / Valvole a rilascio graduale di pressione. / Válvulas de descarga gradual de presión.

\*\*\* Reset relief valves. / Valvole ad azzeramento di pressione. / Válvulas de puesta a cero de la presión.

X Ejector by suction, possibility to control the quantity of detergent suctioned up. / Eiettore per aspirazione, possibilità di regolare la quantità di detergente aspirata. / Eyector para aspiración, se puede regular la cantidad de detergente aspirada.

reg Adjustable detergent suction. / Aspirazione detergente regolabile. / Aspiración detergente regulable.

multifunction Complete with thermo valve, safety valve and chemical injector. / Completa di valvola termostatica, valvola di sicurezza e kit eiettore. / Completa con válvula termostática, válvula de seguridad y kit eyector

□ Nickel unloader valve. / Valvola nichelata. / Válvula niquelada.

✓ Built-in knob kit. / Kit manopola integrata. / Kit de perilla integrada.

**GLYCERINE FILLED PRESSURE GAUGE**

MANOMETRO GLICERINA

MANÓMETRO GLICERINA

**A****B****C**



Model Modello Modelo	Code Codice Codigo	Range Scala Escala	Connections Attacchi Conexiones			For Std. Pumps Per Pompe Serie Para bombas estándar
		bar	centrale / central	radiale / radial		
<b>A</b>	<b>1816 0101</b>	0 - 160	G 1/8		40	BWD BWD/K - LW
<b>A</b>	<b>1816 0075</b>	0 - 250	G 1/4		50	FW2
<b>A</b>	<b>1816 0104</b>	0 - 300	G 1/8		40	BWD - BWD/K - LW AWD - AWD/K - ZW
<b>B</b>	<b>1816 0105</b>	0 - 300	G 1/4		63	FW2 - RW
<b>B</b>	<b>1816 0111</b>	0 - 400	G 1/4		63	RW - TW
<b>B</b>	<b>1816 0155</b>	0 - 600	G 1/4		63	RW - TW
<b>B</b>	<b>1816 0153</b>	0 - 1000	G 1/4		63	TW 500
<b>C</b>	<b>1816 0106</b>	0 - 300		G 1/4	63	FW2
<b>C</b>	<b>1816 0142</b>	0 - 400		G 1/4	63	RW - TW
<b>C</b>	<b>1816 0143</b>	0 - 600		G 1/4	63	RW - TW
<b>C</b>	<b>1816 0144</b>	0 - 1000		G 1/4	63	TW 500

**PRESSURE ACCUMULATOR KIT (WITH "T" COUPLING)**

KIT ACCUMULATORE PRESSIONE (CON RACCORDO A "T")

KIT ACUMULADOR PRESIÓN (CON RACCOR EN "T")

**A****B****C**

Model Modello Modelo	Code Codice Codigo			Charging Pressure Pressione Di Carica Presión de carga		Nominal Pressure Pressione Nominale Presión nominal			Connections Attacchi Conexiones		
		l/min	US g.p.m.	bar	psi	bar	psi		°C	ingresso / inlet	accumul.
<b>A</b>	<b>0102 0032</b>	0,1	0,027	40	580	210	3050	80	-	G 3/8 F	-
<b>A</b>	<b>2803 3388</b>	-	-	-	-	-	-	-	G 3/8 F	G 3/8 M	G 3/8 F
<b>B</b>	<b>0102 0035</b>	0,7	0,19	80	-	210	3050	80	-	M 18 x 1,5 F	-
<b>B</b>	<b>2803 3431</b>	-	-	-	-	-	-	-	G 3/8 F	M 18 x 1,5 F	G 3/8 F
<b>C</b>	<b>0102 0036</b>	0,8	0,21	80	-	300	-	80	-	M 18 x 1,5 F	-
<b>C</b>	<b>2803 3431</b>	-	-	-	-	-	-	-	G 3/8 F	M 18 x 1,5 F	G 3/8 F

All pulsation dampeners are supplied with 80 bar pre-charge, different pre-charge values can be supplied upon request.

Tutti gli accumulatori antipulsazioni sono forniti con precarica di 80 bar, precariche differenti dovranno essere richieste all'atto dell'ordine.

Todos los acumuladores anti pulsaciones se suministran con precarga de 80 bar, precargas diferentes se deberán solicitar al realizar el pedido.

**FLOW SWITCH**

FLUSSOSTATO  
FLUJOSTATO



Model Modello Modelo	Code Codice Codigo					Min. Flow of Activation Portata min. d'Intervento Caudal mínimo de Intervención				Max ampere Ampere max Ampere máx	Connections Attacchi Conexiones	
		l/min	US g.p.m.	bar	psi	H ↔		V ↓			ingresso / inlet	uscita / outlet
A	2421 0041	30	7,9	280	4060	0,6	0,16	0,7	0,18	3	G 3/8 M	G 3/8 M
A	2421 0017	30	7,9	280	4060	2,5	0,66	3	0,79	3	G 3/8 M	G 3/8 M
B	2421 0033	30	7,9	350	5075	3	0,79	4	1,0	3	G 3/8 F	G 3/8 F
B	2421 0019	30	7,9	350	5075	6	1,6	9	2,4	3	G 3/8 F	G 3/8 F
B	2421 0048	30	7,9	640	9282	3	0,79	4	1,0	3	G 3/8 F	G 3/8 F

**R.P.M. DECELERATOR**

DECELERATORE DI GIRI  
REV. DECELERADOR



Model Modello Modelo	Code Codice Codigo			Stroke (from - to) Corsa (da - a) Carrera (desde - hasta)	Connections Attacchi Conexiones
		bar	psi	mm	
A	0608 0094	400	5801	7 - 14	G 3/8 M
B	0608 0096	550	7977	7 - 14	G 3/8 M

**PRESSURE SWITCHES**

PRESSOSTATI  
PRESOSTATOS



Model Modello Modelo	Code Codice Codigo					Color Colore Color	Max ampere Ampere max Ampere máx	Connections Attacchi Conexiones
		bar	psi	bar	psi			
A	2421 0038	15	217	280	4061	Blue / Blu / Azul	6	G 1/4 M
A	2421 0039	15	217	280	4061	Blue / Blu / Azul	6	G 1/8 M
A	2421 0036	25	377	280	4061	Red / Rosso / Rojo	6	G 1/4 M
A	2421 0037	25	377	280	4061	Red / Rosso / Rojo	6	G 1/8 M
A	2421 0040	30	435	280	4061	Green / Verde / Verde	16	G 1/4 M
A	2421 0034	45	652	280	4061	Black / Nero / Negro	16	G 1/4 M
B	2421 0042	25	362	600	8702	-	16	G 3/8 M
B	2421 0047	32	464	600	8702	-	16	G 3/8 M
B	2421 0045	45	652	600	8702	-	16	G 3/8 M

**CHARTS** • *TABELLE* • *TABLAS*

---

**NOZZLES FLOW CHART**

TABELLA PORTATE UGELLI

TABLA DE FLUJO BOQUILLAS

NOZZLE SIZE / MISURA UGELLO / BOQUILLA TAMAÑO

	bar MPa Psi																		
	50 5 725	70 7 1015	100 10 1450	120 12 1740	150 15 2176	180 18 2611	200 20 2901	220 22 3191	250 25 3626	280 28 4061	300 30 4351	350 35 5076	400 40 5802	450 45 6527	500 50 7252	550 55 7977	600 60 8702	650 65 9427	700 70 10153
010	1,6 0,43	1,9 0,50	2,3 0,60	2,5 0,66	2,8 0,74	3,1 0,81	3,2 0,85	3,4 0,89	3,6 0,95	3,8 1,01	3,9 1,04	4,3 1,13	4,6 1,20	4,8 1,28	5,1 1,35	5,3 1,41	5,6 1,47	5,8 1,54	6,0 1,59
015	2,4 0,64	2,9 0,76	3,4 0,90	3,7 0,99	4,2 1,11	4,6 1,21	4,8 1,28	5,1 1,34	5,4 1,43	5,7 1,51	5,9 1,56	6,4 1,69	6,8 1,81	7,3 1,92	7,6 2,02	8,0 2,12	8,4 2,21	8,7 2,30	9,0 2,39
020	3,2 0,85	3,8 1,01	4,6 1,20	5,0 1,32	5,6 1,47	6,1 1,62	6,4 1,70	6,8 1,79	7,2 1,90	7,6 2,02	7,9 2,09	8,5 2,25	9,1 2,41	9,7 2,55	10,2 2,69	10,7 2,82	11,2 2,95	11,6 3,07	12,1 3,19
022	3,5 0,94	4,2 1,11	5,0 1,32	5,5 1,45	6,1 1,62	6,7 1,78	7,1 1,87	7,4 1,96	7,9 2,09	8,4 2,22	8,7 2,29	9,4 2,48	10,0 2,65	10,6 2,81	11,2 2,96	11,8 3,11	12,3 3,24	12,8 3,38	13,3 3,50
025	4,0 1,06	4,8 1,26	5,7 1,51	6,2 1,65	7,0 1,84	7,6 2,02	8,1 2,13	8,5 2,23	9,0 2,38	9,5 2,52	9,9 2,61	10,7 2,82	11,4 3,01	12,1 3,19	12,7 3,37	13,4 3,53	14,0 3,69	14,5 3,84	15,1 3,98
028	4,5 1,19	5,3 1,41	6,4 1,69	7,0 1,85	7,8 2,06	8,6 2,26	9,0 2,38	9,5 2,50	10,1 2,67	10,7 2,82	11,1 2,92	11,9 3,15	12,8 3,37	13,5 3,58	14,3 3,77	15,0 3,95	15,6 4,13	16,3 4,30	16,9 4,46
030	4,8 1,28	5,7 1,51	6,8 1,81	7,5 1,98	8,4 2,21	9,2 2,42	9,7 2,55	10,1 2,68	10,8 2,86	11,4 3,02	11,8 3,13	12,8 3,38	13,7 3,61	14,5 3,83	15,3 4,04	16,0 4,24	16,8 4,42	17,4 4,61	18,1 4,78
033	5,3 1,41	6,3 1,66	7,5 1,99	8,2 2,18	9,2 2,43	10,1 2,67	10,6 2,81	11,2 2,95	11,9 3,14	12,6 3,33	13,0 3,44	14,1 3,72	15,0 3,97	16,0 4,22	16,8 4,44	17,6 4,66	18,4 4,87	19,2 5,07	19,9 5,26
035	5,6 1,49	6,7 1,76	8,0 2,11	8,7 2,31	9,8 2,58	10,7 2,83	11,3 2,98	11,8 3,13	12,6 3,33	13,3 3,53	13,8 3,65	14,9 3,94	16,0 4,22	16,9 4,47	17,8 4,71	18,7 4,94	19,5 5,16	20,3 5,37	21,1 5,58
037	6,0 1,58	7,1 1,86	8,4 2,23	9,2 2,44	10,3 2,73	11,3 2,99	11,9 3,15	12,5 3,30	13,3 3,52	14,1 3,73	14,6 3,86	15,8 4,17	16,9 4,46	17,9 4,73	18,9 4,98	19,8 5,23	20,7 5,46	21,5 5,68	22,3 5,89
040	6,4 1,70	7,6 2,02	9,1 2,41	10,0 2,64	11,2 2,95	12,2 3,23	12,9 3,41	13,5 3,57	14,4 3,81	15,3 4,03	15,8 4,17	17,1 4,51	18,2 4,82	19,3 5,11	20,4 5,39	21,4 5,65	22,3 5,90	23,2 6,14	24,1 6,37
042	6,8 1,79	8,0 2,12	9,6 2,53	10,5 2,77	11,7 3,10	12,8 3,39	13,5 3,58	14,2 3,75	15,1 4,00	16,0 4,23	16,6 4,38	17,9 4,73	19,1 5,06	20,3 5,36	21,4 5,66	22,5 5,93	23,5 6,19	24,4 6,45	25,3 6,69
045	7,3 1,92	8,6 2,27	10,3 2,71	11,2 2,97	12,6 3,32	13,8 3,64	14,5 3,83	15,2 4,02	16,2 4,28	17,2 4,53	17,8 4,69	19,2 5,07	20,5 5,42	21,8 5,75	22,9 6,06	24,1 6,35	25,1 6,64	26,2 6,91	27,1 7,17
050	8,1 2,13	9,5 2,52	11,4 3,01	12,5 3,30	14,0 3,69	15,3 4,04	16,1 4,26	16,9 4,47	18,0 4,76	19,1 5,04	19,7 5,21	21,3 5,63	22,8 6,02	24,2 6,39	25,5 6,73	26,7 7,06	27,9 7,37	29,1 7,68	30,2 7,97
053	8,5 2,26	10,1 2,67	12,1 3,19	13,2 3,50	14,8 3,91	16,2 4,28	17,1 4,51	17,9 4,73	19,1 5,05	20,2 5,34	20,9 5,53	22,6 5,97	24,2 6,38	25,6 6,77	27,0 7,14	28,3 7,48	29,6 7,82	30,8 8,14	32,0 8,44
055	8,9 2,34	10,5 2,77	12,5 3,31	13,7 3,63	15,4 4,06	16,8 4,44	17,7 4,68	18,6 4,91	19,8 5,24	21,0 5,54	21,7 5,74	23,5 6,20	25,1 6,62	26,6 7,03	28,0 7,41	29,4 7,77	30,7 8,11	32,0 8,44	33,2 8,76
060	9,7 2,55	11,4 3,02	13,7 3,61	15,0 3,96	16,8 4,42	18,3 4,85	19,3 5,11	20,3 5,36	21,6 5,71	22,9 6,05	23,7 6,26	25,6 6,76	27,4 7,23	29,0 7,66	30,6 8,08	32,1 8,47	33,5 8,85	34,9 9,21	36,2 9,56
065	10,5 2,77	12,4 3,27	14,8 3,91	16,2 4,29	18,1 4,79	19,9 5,25	21,0 5,54	22,0 5,81	23,4 6,19	24,8 6,55	25,7 6,78	27,7 7,32	29,6 7,83	31,4 8,30	33,1 8,75	34,7 9,18	36,3 9,59	37,8 9,98	39,2 10,36
070	11,3 2,98	13,3 3,53	16,0 4,22	17,5 4,62	19,5 5,16	21,4 5,66	22,6 5,96	23,7 6,25	25,2 6,66	26,7 7,05	27,6 7,30	29,9 7,89	31,9 8,43	33,8 8,94	35,7 9,43	37,4 9,89	39,1 10,32	40,7 10,75	42,2 11,15
075	12,1 3,19	14,3 3,78	17,1 4,52	18,7 4,95	20,9 5,53	22,9 6,06	24,2 6,39	25,4 6,70	27,0 7,14	28,6 7,56	29,6 7,82	32,0 8,45	34,2 9,03	36,3 9,58	38,2 10,10	40,1 10,59	41,9 11,06	43,6 11,51	45,2 11,95
080	12,9 3,41	15,3 4,03	18,2 4,82	20,0 5,28	22,3 5,90	24,5 6,46	25,8 6,81	27,0 7,15	28,8 7,62	30,5 8,06	31,6 8,34	34,1 9,01	36,5 9,63	38,7 10,22	40,8 10,77	42,8 11,30	44,7 11,80	46,5 12,28	48,2 12,75
085	13,7 3,62	16,2 4,28	19,4 5,12	21,2 5,61	23,7 6,27	26,0 6,87	27,4 7,24	28,7 7,59	30,6 8,09	32,4 8,56	33,6 8,87	36,2 9,58	38,8 10,24	41,1 10,86	43,3 11,44	45,4 12,00	47,5 12,54	49,4 13,05	51,3 13,54
090	14,5 3,83	17,2 4,53	20,5 5,42	22,5 5,94	25,1 6,64	27,5 7,27	29,0 7,66	30,4 8,04	32,4 8,57	34,3 9,07	35,5 9,39	38,4 10,14	41,0 10,84	43,5 11,50	45,9 12,12	48,1 12,71	50,3 13,27	52,3 13,82	54,3 14,34
10	16,1 4,26	19,1 5,04	22,8 6,02	25,0 6,60	27,9 7,37	30,6 8,08	32,2 8,52	33,8 8,93	36,0 9,52	38,1 10,08	39,5 10,43	42,6 11,27	45,6 12,04	48,4 12,77	51,0 13,46	53,5 14,12	55,8 14,75	58,1 15,35	60,3 15,93
12	19,3 5,11	22,9 6,05	27,4 7,23	30,0 7,92	33,5 8,85	36,7 9,69	38,7 10,22	40,6 10,72	43,2 11,43	45,8 12,09	47,4 12,52	51,2 13,52	54,7 14,45	58,0 15,33	61,2 16,16	64,1 16,95	67,0 17,70	69,7 18,42	72,4 19,12
15	24,2 6,39	28,6 7,56	34,2 9,03	37,5 9,89	41,9 11,06	45,9 12,12	48,4 12,77	50,7 13,40	54,1 14,28	57,2 15,11	59,2 15,64	64,0 16,90	68,4 18,06	72,5 19,16	76,5 20,20	80,2 21,18	83,8 22,12	87,2 23,03	90,5 23,90
20	32,2 8,52	38,1 10,08	45,6 12,04	49,9 13,19	55,8 14,75	61,2 16,16	64,5 17,03	67,6 17,86	72,1 19,04	76,3 20,15	79,0 20,86	85,3 22,53	91,2 24,09	96,7 25,55	101,9 26,93	106,9 28,24	111,7 29,50	116,2 30,70	120,6 31,86



l/min  
US gpm

**PRESSURE DROPS IN RUBBER HOSES**

PERDITE DI CARICO NEI TUBI ALTA PRESSIONE

TABLA DE CAÍDA DE PRESIÓN EN LOS TUBOS DE GOMA

Pressure drops expressed in bar per 1 meter length of linear hose without fittings.

Specific gravity: 0,85 - Viscosity: 20 centistokes (cs) at 21 °C (70 °F).

Perdite di pressione in bar per una lunghezza del tubo flessibile di 1 m. lineare senza raccordi.

Peso specifico del fluido: 0,85 - Viscosità cinematica: 20 centistokes (cs) a 21 °C.

Caída de presión en bar por una longitud del tubo flexible de 1 m lineal sin racores.

Peso específico del fluido: 0,85 - Viscosidad cinemática: 20 centistokes (cs) a 21 °C.

		inch mm											
		3/16" 4,8	1/4" 6,4	5/16" 7,9	3/8" 9,5	1/2" 12,7	5/8" 15,9	3/4" 19	1" 25,4	1"1/4 31,8	1"1/2 38,1	2" 50,8	3" 76,2
 l/min	1	0,242	0,075										
	2	0,466	0,146	0,066									
	4	0,996	0,293	0,133	0,058								
	8	2,433	0,613	0,250	0,117								
	10	3,540	0,880	0,335	0,144	0,045							
	15		1,776	0,660	0,273	0,068	0,027						
	20		3,080	1,129	0,462	0,116	0,041	0,018					
	30			2,159	0,887	0,228	0,082	0,032					
	40					0,379	0,144	0,050	0,014				
	50					0,555	0,192	0,075	0,021				
	60					0,756	0,263	0,111	0,029	0,009			
	70					0,970	0,373	0,154	0,037	0,013			
	80					1,250	0,475	0,200	0,049	0,016	0,007		
	90					1,531	0,560	0,237	0,066	0,021	0,008		
	100						0,653	0,274	0,073	0,025	0,010	0,003	
	125						0,964	0,393	0,103	0,036	0,014	0,004	
	150							0,567	0,147	0,050	0,019	0,005	
	175							0,735	0,186	0,060	0,026	0,007	
	200							0,920	0,228	0,083	0,033	0,009	
	250								0,347	0,124	0,050	0,013	
300								0,475	0,162	0,068	0,017	0,002	
400								0,832	0,303	0,118	0,032	0,004	
500								1,159	0,425	0,164	0,043	0,006	
600									0,562	0,222	0,057	0,008	
700									0,733	0,301	0,078	0,011	
800									0,924	0,383	0,098	0,014	
900									1,144	0,468	0,118	0,016	
1000										0,553	0,140	0,019	

COMPANY WITH  
QUALITY SYSTEM  
CERTIFIED BY DNV GL  
= ISO 9001 =

Follow us on



[comet-spa.com](http://comet-spa.com)

