

ZW 1400 RPM › FW2 1400 RPM › TW 1400 RPM

ZW › FW2 › TW

Pumps for direct application to Hydraulic Motors • Group 2
 Pompe per applicazione diretta a Motore Idrraulico • Gruppo 2
 Bombas para aplicación directa en Motor Hidráulico • Grupo 2



(E Version) ZW

HOLLOW SHAFT Ø5/8"

For Hydraulic Motor SAE A flange. Flange included.

ALBERO FEMMINA Ø5/8"

Per Motore Idrraulico flangia SAE A. Flangia inclusa.

EJE HEMBRA Ø5/8"

Para Motor Hidráulico brida SAE A. Brida incluida.

(E Version) FW2

HOLLOW SHAFT Ø5/8"

For Hydraulic Motor SAE A flange. Flange included.

ALBERO FEMMINA Ø5/8"

Per Motore Idrraulico flangia SAE A. Flangia inclusa.

EJE HEMBRA Ø5/8"

Para Motor Hidráulico brida SAE A. Brida incluida.

(E Version) TW

HOLLOW SHAFT Ø5/8"

For Hydraulic Motor SAE A flange. Flange included.

ALBERO FEMMINA Ø5/8"

Per Motore Idrraulico flangia SAE A. Flangia inclusa.

EJE HEMBRA Ø5/8"

Para Motor Hidráulico brida SAE A. Brida incluida.

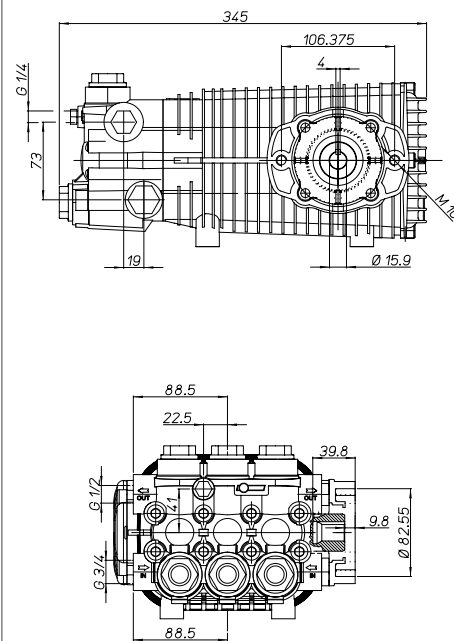
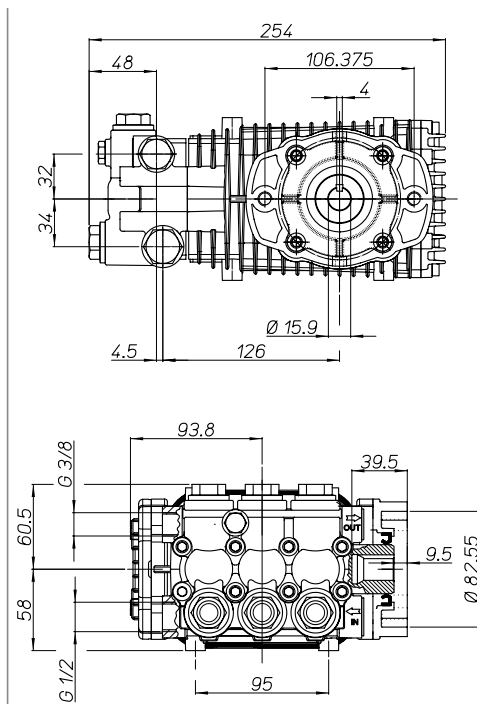
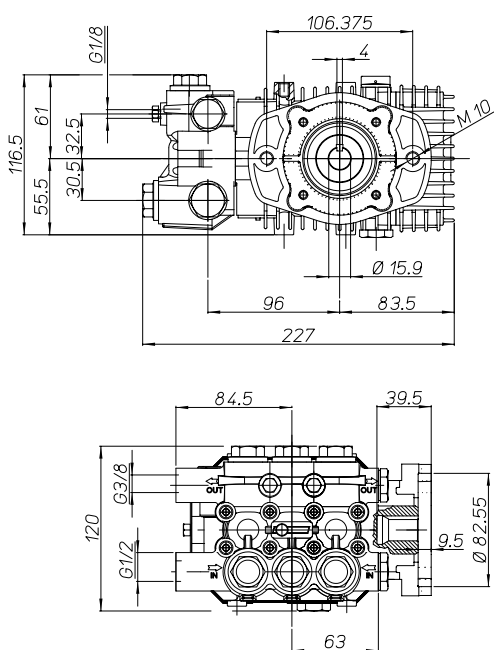

Code Codice Código	Model Modello Modelo	Version	Ø	R.P.M. Giri/min Rev/min	Pressure		Pressure			Power		Weight	
					l/min	U.S.g.p.m.	bar	psi	Mpa	HP	kW	kg	lb
6307 0502	ZW 4030	E	5/8"	1400	15,0	4,0	207	3000	20,7	7,5	5,5	8,0	17,6
6410 0606	FW2 4022	E	5/8"	1400	15,4	4,1	152	2200	15,2	5,5	4	9,3	20,5
6410 0122	FW2 4030	E	5/8"	1400	15,2	4,0	207	3000	20,7	7,5	5,5	9,3	20,5
6513 2200	TW 8022	E	5/8"	1400	33,0	8,7	152	2200	17,2	12,6	9,2	21,0	46,2

All models are supplied with brass head. Standard versions with p.t.o on right hand side.

Tutti i modelli sono forniti con testata in ottone e in versione standard con presa di moto lato destro.

Todos los modelos están disponibles con cabeza de latón y en las versiones estándar con toma de fuerza en el lado derecho.